

THE SINGLE-PHASE DILEMMA: FACT OR FICTION

MOTOR PROTECTION AGAINST SINGLE-PHASING

The Single-Phasing Issue: Fact or Fiction

Overview

Before discussing SINGLE-PHASING, let's take a look at some of the ways that electric motors fail. Historically, the causes of motor failure can be attributed to:

Overloads	30%
Contaminants	19%
Single-phasing	14%
Bearing Failure	13%
Old Age	10%
Rotor Failure	5%
Miscellaneous	9%
	<u>100%</u>

From the above data, it can be seen that 44% of motor failure problems are related to HEAT.

Allowing a motor to reach and operate at a temperature 10°C above its maximum temperature rating will reduce the motor's expected life by 50%. Operating at 10°C above this, the motor's life will be reduced again by 50%. This reduction of the expected life of the motor repeats itself for every 10°C. This is sometimes referred to as the "half life" rule.

Although there is no industry standard that defines the life of an electric motor, it is generally considered to be 20 years.

The term, temperature "rise", means that the heat produced in the motor windings (copper losses), friction of the bearings, rotor and stator losses (core losses), will continue to increase until the heat dissipation equals the heat being generated. For example, a continuous duty, 40°C rise motor will stabilize its temperature at 40°C above ambient (surrounding) temperature.

Standard motors are designed so the temperature rise produced within the motor, when delivering its rated horsepower, and added to the industry standard 40°C ambient temperature rating, will not exceed the safe winding insulation temperature limit.

The term, "Service Factor" for an electric motor, is defined as: "a multiplier which, when applied to the rated horsepower, indicates a permissible horsepower loading which may be carried under the conditions specified for the Service Factor of the motor."

"Conditions" include such things as operating the motor at rated voltage and rated frequency.

Example: A 10 H.P. motor with a 1.0 S.F. can produce 10 H.P. of work without exceeding its temperature rise requirements. A 10 H.P. motor with a 1.15 S.F. can produce 11.5 H.P. of work without exceeding its temperature rise requirements.

Overloads, with the resulting overcurrents, if allowed to continue, will cause heat build-up within the motor. The outcome will be the eventual failure of the motor's insulation. As stated earlier, for all practical purposes, insulation life is cut in half for every 10°C increase over the motor's rated temperature.

Voltage Unbalance

When the voltage between all three phases is equal (balanced), current values will be the same in each phase winding.

The NEMA standard for electric motors and generators recommends that the maximum voltage unbalance be limited to 1%.

When the voltages between the three phases (AB, BC, CA) are not equal (unbalanced), the current increases dramatically in the motor windings, and if allowed to continue, the motor will be damaged.

It is possible, to a limited extent, to operate a motor when the voltage between phases is unbalanced. To do this, the load must be reduced.

Voltage Unbalance in Percent	Derate Motor to These Percentages of the Motor's Rating*
1%	98%
2%	95%
3%	88%
4%	82%
5%	75%

* This is a general "rule of thumb", for specific motors consult the motor manufacturer.

The procedure to determine unbalanced voltages and the corresponding expected rise in heat is discussed on page 3.

Some Causes of Unbalanced Voltage Conditions

- Unequal single-phase loads. This is why many consulting engineers specify that loading of panelboards be balanced to $\pm 10\%$ between all three phases.
- Open delta connections.
- Transformer connections open - causing a single-phase condition.
- Tap settings on transformer(s) not proper.
- Transformer impedances (Z) of single-phase transformers connected into a "bank" not the same.
- Power factor correction capacitors not the same...or off the line.

Insulation Life

The effect of voltage unbalance on the insulation life of a typical T-frame motor having Class B insulation, running in a 40°C ambient, loaded to 100%, is as follows:

Voltage Unbalance	Insulation Life	
	Service Factor 1.0	Service Factor 1.15
0%	1.00	2.27
1%	0.90	2.10
2%	0.64	1.58
3%	—	0.98
4%	—	0.51

Note that motors with a service factor of 1.0 do not have as much heat withstand capability as does a motor that has a service factor of 1.15.

Older, larger U-frame motors, because of their ability to dissipate heat, could withstand overload conditions for longer periods of time than the newer, smaller T-frame motors.

Single-Phasing

Insulation Classes

The following shows the maximum operating temperatures for different classes of insulation.

Class A Insulation	105°C
Class B Insulation	130°C
Class F Insulation	155°C
Class H Insulation	180°C

How to Calculate Voltage Unbalance and the Expected Rise in Heat

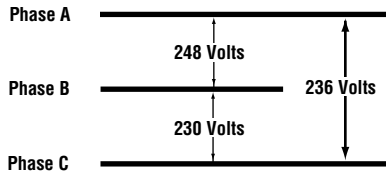

Step 1: Add together the three voltage readings:
 $248 + 236 + 230 = 714$ volts

Step 2: Find the “average” voltage.

$$\frac{714}{3} = 238 \text{ volts}$$

Step 3: Subtract the “average” voltage from one of the voltages that will indicate the **greatest** voltage difference. In this example:

$$248 - 238 = 10 \text{ volts}$$

Step 4:

$$100 \times \frac{\text{greatest voltage difference}}{\text{average voltage}}$$

$$= 100 \times \frac{10}{238} = 4.2 \text{ percent voltage unbalance}$$

Step 5: Find the expected temperature rise in the phase winding with the highest current by taking...

$$2 \times (\text{percent voltage unbalance})^2$$

In the above example:

$$2 \times (4.2)^2 = 35.28 \text{ percent temperature rise.}$$

Therefore, for a motor rated with a 60°C rise, the unbalanced voltage condition in the above example will result in a temperature rise in the phase winding with the highest current of:

$$60^\circ\text{C} \times 135.28\% = 81.17^\circ\text{C}$$

The National Electrical Code

The National Electrical Code, in Table 430-37, requires three overload protective devices, one in each phase, for the protection of all three-phase motors.

Prior to the 1971 National Electrical Code, three-phase motors were considered to be protected from overload (over-current) by two overload protective devices. These devices could be in the form of properly sized time-delay, dual-element fuses, or overload heaters and relays (melting alloy type, bimetallic type, magnetic type, and solid-state type. See Figure 1.

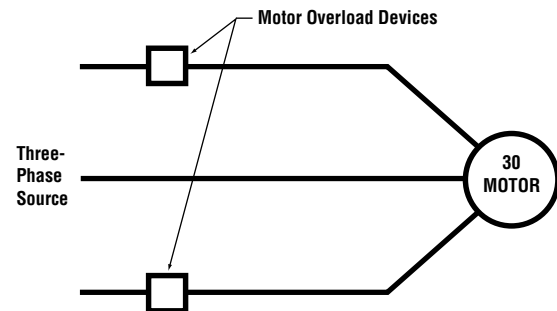

Figure 1. Diagram showing two overload devices protecting a three-phase motor. This was acceptable by the National Electrical Code prior to 1971.

Two motor overload protective devices provide adequate protection against balanced voltage overload conditions where the voltage between phases is equal. When a balanced voltage overload persists, the protective devices usually open simultaneously. In some cases, one device opens, and shortly thereafter, the second device opens. In either case, three-phase motors are protected against balanced voltage overload conditions.

Three-phase motors protected by two overload protective devices are not assured protection against the effect of single-phasing. For example, when the electrical system is WYE/DELTA or DELTA/WYE connected, all three phases on the secondary side of the transformer bank will continue to carry current when a single-phasing caused by an open phase on the primary side of the transformer bank occurs. As will be seen later, single-phasing can be considered to be the **worst case** of unbalanced voltage possible.

Single-Phasing

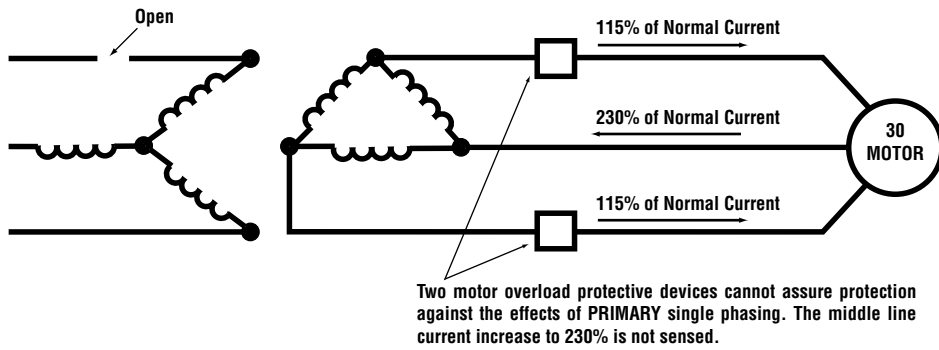

Figure 2. Diagram of a WYE/DELTA transformation with one primary phase open. The motor is protected by two overload devices. Note that one phase to the motor is carrying two times that of the other two phases. Without an overload device in the phase that is carrying two times the current in the other two phases, the motor will burn out.

The 1993 National Electrical Code, Section 430-36 requires that when fuses are used for motor overload protection, a fuse shall be inserted in each phase. Where thermal overload devices, heaters, etc. are used for motor overload protection, Table 430-37 requires one be inserted in each phase. With these requirements, the number of single-phasing motor burnouts are greatly reduced, and are no longer a serious hazard to motor installations. Figure 3 shows three overload protective devices protecting the three-phase motor.

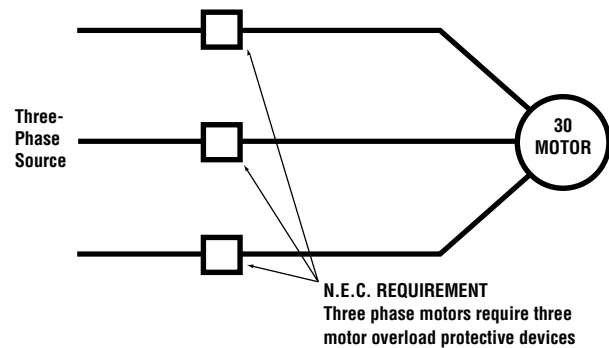

Figure 3. Since 1971, The National Electrical Code has required three overload protective devices for the protection of three-phase motors, one in each phase.

Motor Branch Circuit, Short Circuit and Ground Fault Protection

When sized according to NEC Section 430-52, a 3-pole common trip circuit breaker or MCP cannot protect against single-phasing damage.

It should be emphasized, the causes of single-phasing cannot be eliminated. However, motors can be protected from the damaging effects of single-phasing through the use of proper overcurrent protection.

Dual-element, time-delay fuses can be sized at or close to the motor's nameplate full-load ampere rating without opening on normal motor start-up. This would require sizing the fuses at 100-125% of the motors full-load current rating. Since all motors are not necessarily fully loaded, it is recommended that the actual current draw of the motor be used instead of the nameplate rating. This is possible for motors

that have a fixed load, but not recommended where the motor load varies.*

Thus, when single-phasing occurs, FUSETRON® and LOW-PEAK® dual-element, time-delay fuses will sense the overcurrent situation and respond accordingly to take the motor off the line.

For motor branch-circuit protection only, the following sizing guidelines† per section 430-52 of the National Electrical Code are allowed.

	<u>Normal</u>	<u>Maximum</u>
• Dual-element, time delay fuses	175%	225%
• Non-time-delay fuses	300%	400%
• Inverse-time circuit breaker	250%	400% for motors 100 amperes or less. 300% for motors more than 100 amperes.
• Instantaneous only trip** circuit breakers (sometimes referred to as MCPs. These are motor circuit protectors... not motor protectors.)	700%	1300%

†See NEC 430-52 for specifics and exceptions.

Note: When sized according to table 430-152, none of these overcurrent devices can provide single-phasing protection.

Refer to Bussmann's Protection Handbook for more detailed discussion on the subject of motor overload, branch-circuit, and ground fault protection.

* When sizing to the actual running current of the motor is not practical, an economic analysis can determine if the addition of one of the electronic "black boxes" is financially justified. These electronic "black boxes" can sense voltage and current unbalance, phase reversal, single phasing, etc.

** Instantaneous only trip breakers are now permitted to have time delay. This could result in more damaging let-thru current during short circuits.

Single-Phasing Causes

Single-Phasing

The term **single-phasing**, means one of the phases is open. A single-phasing condition subjects an electric motor to the **worst possible case** of voltage unbalance.

If a three-phase motor is running when the “single-phase” condition occurs, it will attempt to deliver its full horsepower...enough to drive the load. The motor will continue to try to drive the load...until the motor burns out...or until the properly sized overload elements and/or properly sized dual-element, time-delay fuses take the motor off the line.

For lightly loaded three-phase motors, say 70% of normal full-load amperes, the phase current will increase by the square root of three ($\sqrt{3}$) under secondary single-phase conditions. This will result in a current draw of approximately 20% more than the nameplate full load current. If the overloads are sized at 125% of the motor nameplate, circulating currents can still damage the motor. That is why it is recommended that motor overload protection be based upon the actual running current of the motor under its given loading, rather than the nameplate current rating.

Single-Phasing Causes Are Numerous

One fact is sure: Nothing can prevent or eliminate all types of single-phasing.

There are numerous causes of both primary and secondary single-phasing. A device must sense and respond to the resulting increase in current when the single-phasing condition occurs...and do this in the proper length of time to save the motor from damage.

The term “single-phasing” is the term used when one phase of a three-phase system opens. This can occur on either the primary side or secondary side of a distribution transformer. Three-phase motors, when not individually protected by three time-delay, dual-element fuses, or three overload devices, are subject to damaging overcurrents caused by **primary** single-phasing or **secondary** single-phasing.

Single-Phasing on Transformer Secondary – Typical Causes

1. Damaged motor starter contact-one pole open. The number of contact kits sold each year confirms the fact that worn motor starter contacts are the most common cause of single-phasing. Wear and tear of the starter contacts can cause contacts to burn open, or develop very high contact resistance, resulting in single-phasing. This is most likely to occur on automatically started equipment such as air conditioners, compressors, fans, etc.
2. Burned open overload relay (heater) from a line-to-ground fault on a 3 or 4 wire grounded system. This is more likely to occur on smaller size motor starters that are protected by non-current-limiting overcurrent protective devices.
3. Damaged switch or circuit breaker on the main, feeder, or motor branch circuit.
4. Open fuse or open pole in circuit breaker on main, feeder, or motor branch circuit.
5. Open cable or bus on secondary of transformer terminals.
6. Open cable caused by overheated lug on secondary side connection to service.
7. Open connection in wiring such as in motor junction box (caused by vibration) or any pull box. Poor connections, particularly when aluminum conductors are not properly spliced to copper conductors, or when aluminum conductors are inserted into terminals and lugs suitable for use with copper conductors or copper-clad conductors only.
8. Open winding in motor.
9. Open winding in one phase of transformer.
10. **ANY** open circuit in **ANY** phase **ANYWHERE** between the secondary of the transformer and the motor.

Single-Phasing Causes

Hazards of Secondary Single-Phasing for a Three-Phase Motor

When one phase of a secondary opens, the current to a motor in the two remaining phases theoretically increase to 1.73 (173%) times the normal current draw of the motor. The increase can be as much as 2 times (200%) because of power factor changes. Where the motor has a high inertia load, the current can approach locked rotor values under single-phased conditions. Figures 4A, 4B and 4C illustrate the 173% current increase. Three properly sized time-delay, dual-element fuses, and/or three properly sized overload devices will sense and respond to this overcurrent.

SINGLE-PHASING ON SECONDARY

NORMAL CONDITION

SINGLE-PHASING CONDITION

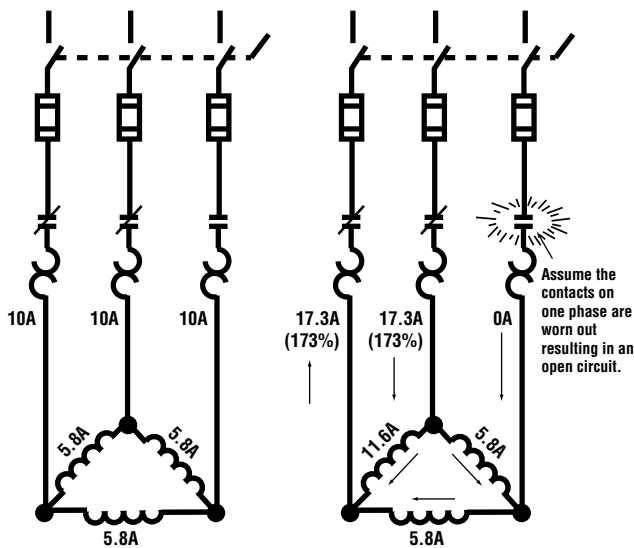

Delta-Connected Motor
FLA = 10 Amperes

Figure 4A. (Delta-Connected Motor) Diagram showing the increase in current in the two remaining phases after a single-phasing occurs on the secondary of a transformer.

SINGLE-PHASING ON SECONDARY

NORMAL CONDITION

SINGLE-PHASING CONDITION

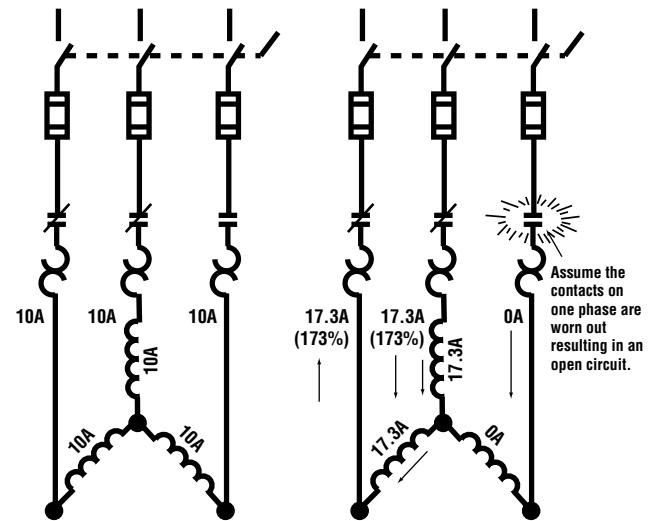

WYE-Connected Motor
FLA = 10 Amperes

Figure 4B. (WYE-Connected Motor) Diagram showing the increase in current in the two remaining phases after a single-phasing occurs on the secondary of a transformer.

Single-Phasing Causes

SINGLE-PHASING ON SECONDARY

NORMAL CONDITION

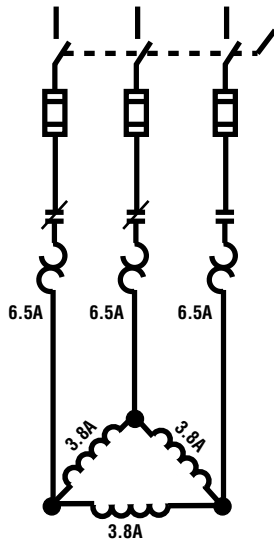

SINGLE-PHASING CONDITION

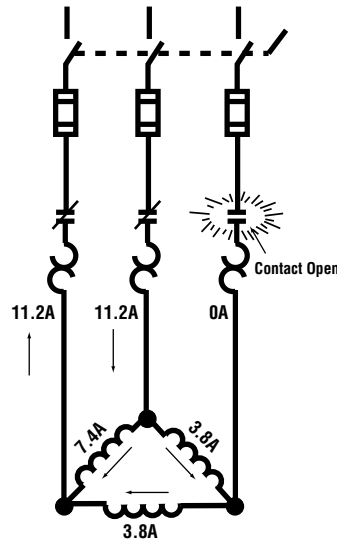

Figure 4C. Delta-connected three-phase motor loaded to only 65% of its rated horsepower. Normal FLA = 10 amperes. Overload (overcurrent) protection should be based upon the motor's actual current draw for the underloaded situation for optimum protection. If load varies, overload protection is difficult to achieve. Temperature sensors, phase failure relays and current differential relays should be installed.

When a motor is single-phased, the current in the remaining two phases increases to 173% of normal current. Normally the overload relays will safely clear the motor from the power supply. However, should the overload relays or controller fail to do so, LOW-PEAK® or FUSETRON® time-delay, dual-element fuses properly sized to provide back-up overload protection will clear the motor from its power supply. (See page 9.)

Single-Phasing on Transformer Primary – Typical Causes

1. Primary wire broken by:
 - a. Storm – wind
 - b. Ice – sleet – hail
 - c. Lightning
 - d. Vehicle or airplane striking pole or high-line
 - e. Falling trees or tree limbs
 - f. Construction mishaps
2. Primary wire burned off from short-circuit created by birds or animals.
3. Defective contacts on primary breaker or switch – failure to make up on all poles.
4. Failure of 3-shot automatic recloser to make up on all 3 poles.
5. Open pole on 3-phase automatic voltage tap changer.
6. Open winding in one phase of transformer.
7. Primary fuse open.

Hazards of Primary Single-Phasing for a Three-Phase Motor

Probably the most damaging single-phase condition is when one phase of the primary side of WYE/DELTA or DELTA/WYE transformer is open. Usually these causes are not within the control of the user who purchases electrical power. When primary single-phasing occurs, unbalanced voltages appear on the motor circuit, causing excessive unbalanced currents. This was covered earlier in this bulletin.

When primary single-phasing occurs, the motor current in one secondary phase increases to 230% of normal current. Normally, the overload relays will protect the motor. However, if for some reason the overload relays or controller fail to function, the LOW-PEAK® or FUSETRON® dual-element fuses properly sized to provide overload protection will clear the motor from the power supply.

Figures 5A and 5B illustrate the change in current for a WYE PRIMARY and DELTA SECONDARY.

Single-Phasing Causes

SINGLE-PHASING ON PRIMARY

Delta-Connected Motor; FLA = 10 Amperes

NORMAL CONDITION

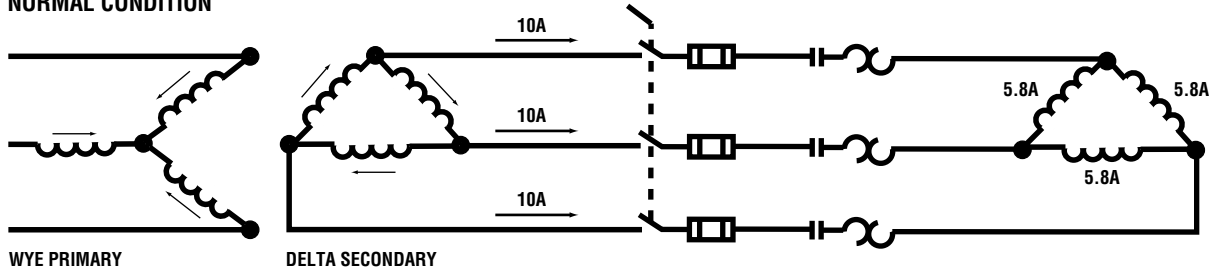

SINGLE-PHASING CONDITION

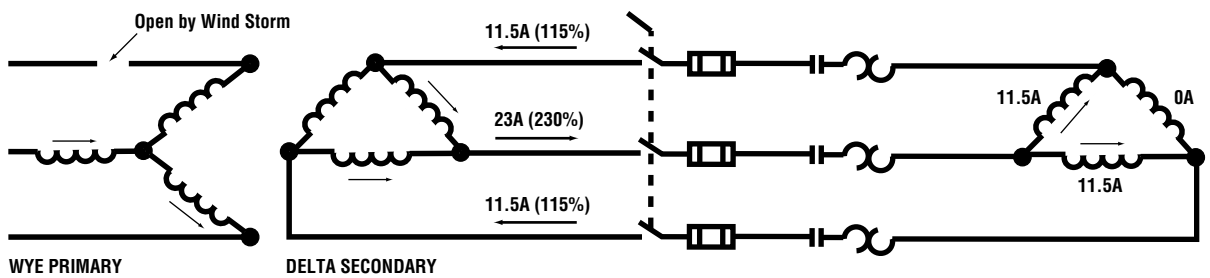
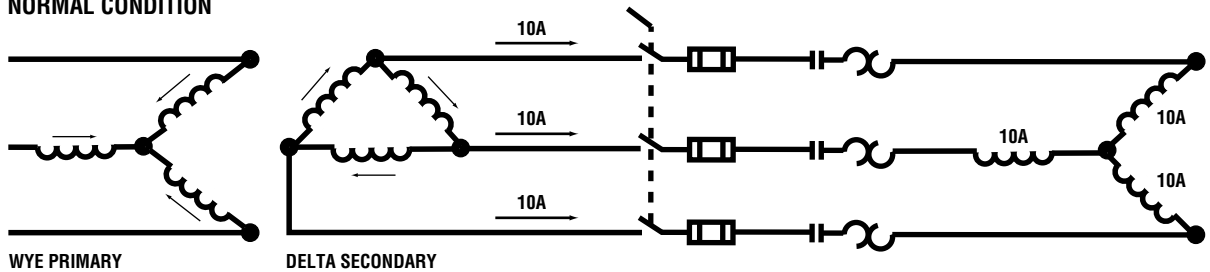

Figure 5A. (Delta-Connected Motor) Diagram showing how the phase currents to a three-phase motor increase when a single-phasing occurs on the primary. For older installations where the motor is protected by two overload devices, the phase winding having the 230% current will burn up. However, properly sized overload relays or LOW-PEAK® or FUSETRON® dual-element, time-dealy fuses will clear the motor from the power supply.

SINGLE-PHASING ON PRIMARY

Wye-Connected Motor; FLA = 10 Amperes

NORMAL CONDITION



SINGLE-PHASING CONDITION

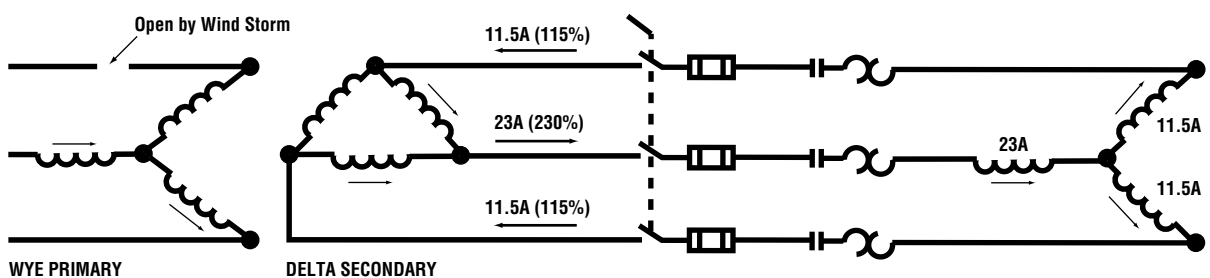
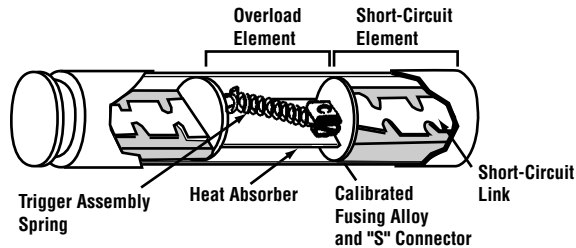

Figure 5B. (Wye-Connected Motor) Diagram showing how the phase currents to a three-phase motor increase when a single-phasing occurs on the primary. For older installations where the motor is protected by two overload devices, the phase winding having the 230% current will burn up. However, properly sized overload relays or LOW-PEAK® or FUSETRON® dual-element, time-dealy fuses will clear the motor from the power supply.

Sizing Overcurrent Devices for Single-Phasing Conditions

Overload Characteristics

LOW-PEAK® and FUSETRON® dual-element, time-delay fuses have an intentional “built-in” time-delay feature that enables these fuses to hold the typical motor’s normal starting inrush current, yet open under sustained overloads or overcurrent conditions caused by single-phasing. These fuses are designed to carry 5 times their label rating for a minimum of 10 seconds*.



LOW-PEAK® and FUSETRON® dual-element, time-delay fuses provide the most reliable overcurrent protection for motor circuits because of their time-delay overload characteristics and their current-limited short-circuit characteristics. The same set of fuses performs both motor overload protection (Article 430, Part C) and motor branch circuit and ground fault protection (Article 430, Part D). It is significant to note that thermal overloads and similar devices are intended to operate in the range of locked rotor currents or less. They are **not** intended to function as motor branch-circuit and ground fault protective devices.

The most practical way of providing motor protection with conventional equipment is to individually protect each three-phase motor against the **effects** of single-phasing by installing three (3) properly sized time-delay, dual-element fuses and/or three (3) properly sized thermal overload devices. Inherently protected motors that sense voltage and current unbalances, temperature extremes, and phase failure relays that sense the loss of one phase are also used.

Field experience has shown that three time-delay, dual-element fuses, sized for motor overload (overcurrent) protection will offer practical protection against motor burnouts caused by normal overloads and single-phasing conditions. This type of fuse can be sized close to the motor’s full-load ampere rating without needlessly opening on normal motor start up.

These fuses have the ability to override the momentary, harmless inrush current that occurs under most motor start-up conditions.

Where the motor is subjected to abnormal starting conditions, such as high inertia loads (slow to come up to speed), or is repetitively started and stopped, causing the motor windings to get too hot, the fuses will sense these repetitive surges of current, and will open in time to protect the motor against burnout.

Bussmann’s Protection Handbook Bulletin SPD covers the subject of motor overload protection in great detail.

*8 seconds for 0-30 ampere, 250 Volt Class RK1 and RK5.

Sizing Overcurrent Devices for Single-Phase Conditions

Dual-Element, Time-Delay Fuses Only

Figures 6A and 6B illustrate the proper application of time-delay, dual-element fuses for protection against single-phase burnout and other overload problems when no other motor running overload protection devices are used.

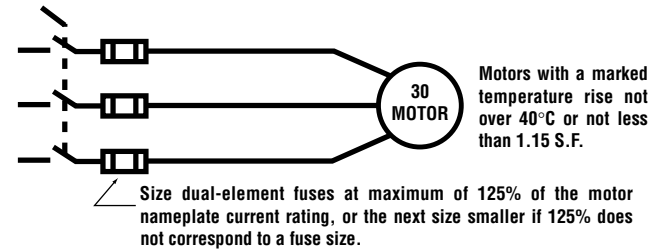

Figure 6A. 40°C or 1.15 S.F. Motors

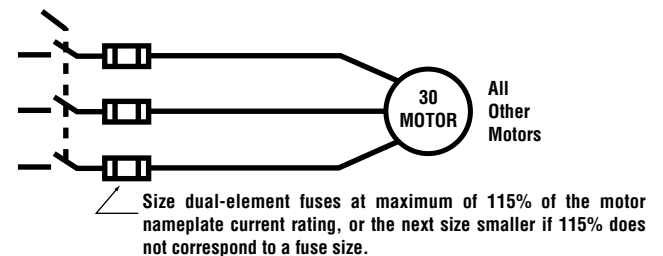

Figure 6B. All Other Motors (Over 40°C or Less Than 1.15 S.F.)

Figures 6A and 6B are diagrams showing the application for LOW-PEAK® and FUSETRON® dual-element, time-delay fuses as the only means of providing motor overload (overcurrent) protection to conform to Article 430, Part C. Note that there are three fuses...one in each phase per the requirements of Section 430-36, National Electrical Code. Figure 6A shows a motor having a Service Factor of 1.15. Figure 6B shows a motor having a Service Factor of less than 1.15.

Back-up Protection – The Optimum Choice

Most installations today have motor controllers with three overload devices (heaters, relays, etc.) that provide the motor overload protection as required by the National Electrical Code. For these applications, time-delay, dual element fuses are generally sized to offer “back-up” overload (overcurrent) protection. This adds a second “line-of-defense”, providing an additional degree of motor overload protection. Normally, any overcurrent condition, including those caused by SINGLE-PHASING, is sensed and cleared by the three overload devices in conjunction with the motor controller.

Sizing Overcurrent Devices for Single-Phasing Conditions

However, if these overload devices are oversized, if the relay coil or solenoid is jammed, or if the contacts in the controller are welded shut (a common occurrence when the contacts close in on a short-circuit), the time-delay, dual-element fuses will sense and respond to the overcurrent situation. This is what is meant by “back-up” protection. Sports enthusiasts understand this concept when sitting behind home plate. Should the catcher miss the ball...it is nice to have the screen between the fans and the catcher. Double protection at no extra cost.

Overload Relays and Dual-Element Fuses

Figure 7A and 7B show a motor protected by overload devices in the controller, plus “back-up” protection in the form of fuses. These fuses can be installed in the motor’s disconnect switch. The disconnect switch can be remotely located...or it can be part of a combination starter.

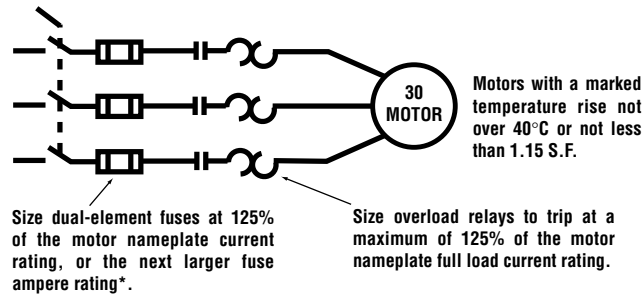

Figure 7A. 40°C or 1.15 S.F. Motors

* When 125% of the motor nameplate current rating does not coincide with a dual-element fuse ampere rating, the next larger fuse ampere rating is recommended to achieve maximum coordination. As the fuse size increases greater than 125%, the degree of motor overload protection decreases. However, the overload relays are intended primarily to operate on motor overloads and the dual-element fuses function as back-up protection.

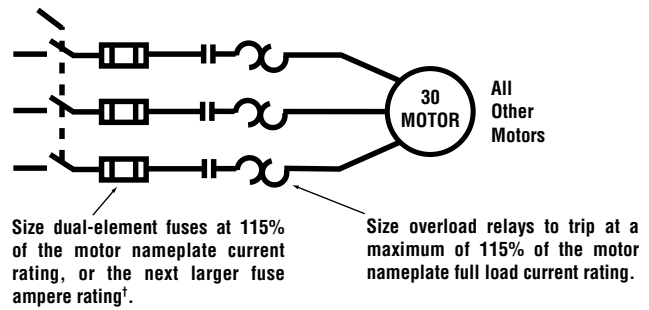

Figure 7B. All Other Motors (Over 40°C or Less Than 1.15 S.F.)

† When 115% of the motor nameplate current rating does not coincide with a dual-element fuse ampere rating, the next larger fuse ampere rating is recommended to achieve maximum coordination. As the fuse size increases greater than 115%, the degree of motor overload protection decreases. However, the overload relays are intended primarily to operate on motor overloads and the dual-element fuses function as back-up protection.

Effects of Single-Phasing on Various Types of Loads

Protecting each individual motor with properly sized LOW-PEAK® and FUSETRON® dual-element, time-delay fuses provides the simplest, most practical overall system protection against the effects of single-phasing. This type of protection assures maximum continuity of service for as long as possible. Regardless of whether the primary, a main, feeder, or branch circuit is single-phased, individual three-phase motors remain in operation until the overcurrent caused by the single-phasing condition warrants action and the motor starter or dual-element fuses operate – thus continuity of the motor loads are maintained for as long as practical. Other types of loads not subject to damage from single-phasing conditions remain in operation and continuity of service is maintained. Often the change in voltages under a single-phasing condition effect the output of other type loads, but continuity of service is maintained.

1. Effects of Single-Phasing on Single-Phase and Three-Phase Ovens or Heaters.

a. Single-phase ovens or heaters on the open phase discontinue operation.

Single-phase ovens or heaters on the other two phases continue in operation.

b. Three-phase ovens or heaters are not damaged by single-phasing. Usually, the heat output is reduced dependent upon the voltage change.

2. Effect of Single-Phasing on Lighting. Lights are single phase devices. Should a secondary single-phasing occur because of a main or feeder fault in a fused system, two-thirds of the lights remain in operation. This is very important since a total blackout to an area or building could be costly and a serious safety hazard. Blackouts in hospitals, nursing homes, shopping centers, or anywhere people congregate cannot be tolerated.

3. Effect of Single-Phasing on Controls. Controls either remain “on” or “drop out” depending on the nature of the single-phasing and type of control device.

4. Effect of Single-Phasing on Single-Phase Motors.

a. Single-phase motors on the open phase discontinue operation.

b. Primary single-phasing may affect single-phase motors due to voltage fluctuations. Protect individual single phase motors with LOW-PEAK® and FUSETRON® dual-element fuses or other means of running overload protection.

5. Effect of Single-Phasing on Three-Phase Motors.

The effects of single-phasing on three-phase motors varies with service conditions and motor thermal capacities. When single phased, the motor temperature rise may not vary directly with the motor current. When single-phased, the motor temperature rise may increase at a rate greater than the increase in current. In some cases, protective devices which sense only current may not provide complete single-phasing protection. However, PRACTICAL experience has demonstrated that motor running overload devices properly sized and maintained can greatly reduce the problems of single-phasing for the majority of motor installations. In some instances, additional protective means may be necessary when a higher degree of single-phasing protection is required. Generally, smaller horsepower rated motors have more thermal capacity than larger horsepower rated motors and are more likely to be protected by conventional motor running overload devices.

Conclusion

The causes of single-phasing are too numerous to prevent the occurrence of a single-phasing condition on an electrical system. Therefore, it is essential to protect against the effects of single-phasing. The National Electrical Code recognized this need, and since 1971 has required three motor running overload protective devices for each three-phase motor. Since the enactment of this requirement, single-phasing no longer is a serious problem. It does not matter if a single-phasing condition is caused by an open primary line or by an open secondary line, three properly sized motors running overload protective devices will offer protection to three-phase motors. For the most practical single-phasing protection, field experience has shown each individual three-phase motor can be protected with three overload relays, inherent motor protection, and/or three dual-element fuses.

REMEMBER: it is always more economical to occasionally change LOW-PEAK® or FUSETRON® dual-element, time-delay fuses than to change out a burned out motor.

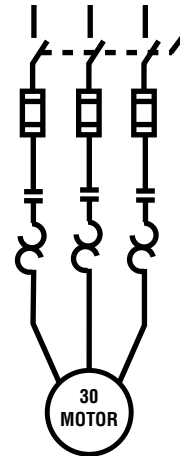

This Bulletin is intended to clearly present comprehensive product data and provide technical information that will help the end user with design applications. Bussmann reserves the right, without notice, to change design or construction of any products and to discontinue or limit distribution of any products. Bussmann also reserves the right to change or update, without notice, any technical information contained in this Bulletin. Once a product has been selected, it should be tested by the user in all possible applications.

Bussmann, P.O. Box 14460, St. Louis, MO 63178-4460 • (314) 394-2877 • Customer Satisfaction (314) 527-3877: Fax (800) 544-2570 • International Fax (314) 527-1445



Quality from
Cooper Industries

Bussmann
Weltenburger Str. 70
W8000 München 80
Germany
Phone +(089) 92404-138
Fax +(089) 92404-200

Bussmann
Literbuen 5
DK-2740 Skovlunde, Copenhagen
Denmark
Phone +45 42-919900
Phone +45 42-911151
Fax +65-2275384

Bussmann
Prince Edward Road
No. 04-07 Finger Pier
Building
Singapore 0207
Republic of Singapore
Phone +65-2275346

Bussmann
Beswick Works,
Frome, Somerset BA11 1PP
England
Phone +44-373-464311
Fax +44-373-473175

Copyrighted May 1993 by Cooper Industries, Inc., Bussmann Division, Printed in U.S.A.