

# IEEE Guide for Cable Connections for Gas-Insulated Substations

Sponsor

**Insulated Conductors Committee  
of the  
IEEE Power Engineering Society**

Approved 1 August 1996

**IEEE Standards Board**

**Abstract:** The coordination of design, material supply, installation, and test procedures required for the connection of a gas-insulated substation (GIS) is described. Preferred dimensions for mechanical and electrical interchangeability for voltage classes of 69 kV and above are established.

**Keywords:** cable connection, gas-insulated substation (GIS)

---

The Institute of Electrical and Electronics Engineers, Inc.  
345 East 47th Street, New York, NY 10017-2394, USA

Copyright © 1996 by the Institute of Electrical and Electronics Engineers, Inc.  
All rights reserved. Published 1996. Printed in the United States of America.

ISBN 1-5597-750-X

*No part of this publication may be reproduced in any form, in an electronic retrieval system or otherwise, without the prior written permission of the publisher.*

**IEEE Standards** documents are developed within the IEEE Societies and the Standards Coordinating Committees of the IEEE Standards Board. Members of the committees serve voluntarily and without compensation. They are not necessarily members of the Institute. The standards developed within IEEE represent a consensus of the broad expertise on the subject within the Institute as well as those activities outside of IEEE that have expressed an interest in participating in the development of the standard.

Use of an IEEE Standard is wholly voluntary. The existence of an IEEE Standard does not imply that there are no other ways to produce, test, measure, purchase, market, or provide other goods and services related to the scope of the IEEE Standard. Furthermore, the viewpoint expressed at the time a standard is approved and issued is subject to change brought about through developments in the state of the art and comments received from users of the standard. Every IEEE Standard is subjected to review at least every five years for revision or reaffirmation. When a document is more than five years old and has not been reaffirmed, it is reasonable to conclude that its contents, although still of some value, do not wholly reflect the present state of the art. Users are cautioned to check to determine that they have the latest edition of any IEEE Standard.

Comments for revision of IEEE Standards are welcome from any interested party, regardless of membership affiliation with IEEE. Suggestions for changes in documents should be in the form of a proposed change of text, together with appropriate supporting comments.

Interpretations: Occasionally questions may arise regarding the meaning of portions of standards as they relate to specific applications. When the need for interpretations is brought to the attention of IEEE, the Institute will initiate action to prepare appropriate responses. Since IEEE Standards represent a consensus of all concerned interests, it is important to ensure that any interpretation has also received the concurrence of a balance of interests. For this reason, IEEE and the members of its societies and Standards Coordinating Committees are not able to provide an instant response to interpretation requests except in those cases where the matter has previously received formal consideration.

Comments on standards and requests for interpretations should be addressed to:

Secretary, IEEE Standards Board  
445 Hoes Lane  
P.O. Box 1331  
Piscataway, NJ 08855-1331  
USA

Note: Attention is called to the possibility that implementation of this standard may require use of subject matter covered by patent rights. By publication of this standard, no position is taken with respect to the existence or validity of any patent rights in connection therewith. The IEEE shall not be responsible for identifying all patents for which a license may be required by an IEEE standard or for conducting inquiries into the legal validity or scope of those patents that are brought to its attention.

Authorization to photocopy portions of any individual standard for internal or personal use is granted by the Institute of Electrical and Electronics Engineers, Inc., provided that the appropriate fee is paid to Copyright Clearance Center. To arrange for payment of licensing fee, please contact Copyright Clearance Center, Customer Service, 222 Rosewood Drive, Danvers, MA 01923 USA; (508) 750-8400. Permission to photocopy portions of any individual standard for educational classroom use can also be obtained through the Copyright Clearance Center.

## Introduction

(This introduction is not a part of IEEE Std 1300-1996, IEEE Guide for Cable Connections for Gas-Insulated Substations.)

This guide serves to explain detailed requirements for cable connections for gas-insulated substations. The guide was prepared as Project 10-52 of the Accessories Subcommittee No. 10 of the Insulated Conductors Committee of the IEEE Power Engineering Society. It is based on IEC Publication 859 (1986), Cable Connections for Gas-Insulated Metal Enclosed Switchgear for Rated Voltages of 72.5 kV and above.

The chair of the Insulated Conductors Committee at the time IEEE Std 1300-1996 was being prepared was Charles A. White. The chair of the Accessories Subcommittee was Robert B. Gear.

The following is a list of participants in the Working Group:

### **Philip C. Bolin, *Chair***

Vincent J. Boliver  
Daniel D. R. Charbonnet  
Mark W. Conroy  
Joseph A. DiConstanzo  
Robert B. Gear  
Jack Hand

### **John H. Cooper, *Vice Chair***

William G. Hansen  
Mel Hopkins  
Ralph E. Hoy  
Richard A. Jones  
Fred Kimsey

Alfred A. Liebold  
Russ Matulic  
Jack Phillips  
John H. Sherry  
Gilbert L. Smith  
Milan Uzelac

The following persons were on the balloting committee:

Torben Aabo  
Theodore A. Balaska  
Vincent J. Boliver  
Michael D. Buckweitz  
Claus Doench  
John S. Engelhardt  
Arthur R. Fitzpatrick  
S. Michael Foty  
Ronald F. Frank  
Robert B. Gear

Kenneth Hancock  
Richard A. Hartlein  
Lauri J. Hiivala  
Fred Kimsey  
Gabor Ludasi  
James A. Moran, Jr.  
Shantanu Nandi  
Gary Polhill  
Ronald J. Ponist  
Robert A. Resuali

Candelario de J. Saldivar Cantu  
Gilbert L. Smith  
Matthew H. Spalding  
Nagu N. Srinivas  
Duc B. Trinh  
Stephen E. Turner  
Steven P. Walldorf  
Roland H. W. Watkins  
John L. White  
Joseph T. Zimnoch

When the IEEE Standards Board approved this standard on 1 August 1996, it had the following membership:

**Donald C. Loughry**, *Chair*

**Richard J. Holleman**, *Vice Chair*

**Andrew G. Salem**, *Secretary*

Gilles A. Baril  
Clyde R. Camp  
Joseph A. Cannatelli  
Stephen L. Diamond  
Harold E. Epstein  
Donald C. Fleckenstein  
Jay Forster\*  
Donald N. Heirman

Ben C. Johnson  
E. G. "Al" Kiener  
Joseph L. Koepfinger\*  
Lawrence V. McCall  
L. Bruce McClung  
Marco W. Migliaro  
Mary Lou Padgett  
John W. Pope  
Jose R. Ramos

Arthur K. Reilly  
Ronald H. Reimer  
Gary S. Robinson  
Ingo Rüsçh  
John S. Ryan  
Chee Kiow Tan  
Leonard L. Tripp  
Howard L. Wolfman

\*Member Emeritus

Also included are the following nonvoting IEEE Standards Board liaisons:

Satish K. Aggarwal  
Alan H. Cookson  
Chester C. Taylor

Lisa S. Young  
*IEEE Standards Project Editor*

Figures 1, 2, 3 and table 1 are reproduced with the permission of the International Electrotechnical Commission (IEC). No part of this material may be reproduced in any form, including an electronic retrieval system, without the prior written permission of the IEC.

# Contents

CLAUSE	PAGE
1. Overview .....	1
2. References.....	1
3. Definitions.....	1
4. Limits of supply .....	3
5. Typical dimensions .....	5
6. Ratings .....	7
7. Temperature rise and conductor contact surfaces .....	7
8. Gas pressure .....	7
9. Dielectric type test .....	8
9.1 Cable termination dielectric type test .....	8
9.2 Cable connection enclosure dielectric type test .....	8
9.3 Isolating gap.....	8
10. Mechanical force (short circuit and other).....	9
11. Cable connection support structures .....	9
12. Grounding .....	9
13. Installation.....	12
14. Field tests .....	12
14.1 Dielectric field tests .....	12
14.2 Other field tests .....	12
15. Operation and maintenance.....	12
16. Special accessories.....	13
16.1 Vent and sample valve for fluid filled cables .....	13
16.2 Detection of cable fluid leaks inside cable termination enclosure.....	13
16.3 Viewports .....	13
17. Bibliography .....	13



# IEEE Guide for Cable Connections for Gas-Insulated Substations

## 1. Overview

Connection of a gas-insulated substation (GIS) to cables typically requires the coordination of design, material supply, installation, and test procedures of several different parties. This guide provides detailed directions for such coordination and establishes preferred dimensions for mechanical and electrical interchangeability for voltage classes of 69 kV and above. The general principles are applicable at all voltage levels.

## 2. References

The following publications should be used in conjunction with this guide:

IEC Publication 859 (1986), Cable Connections for Gas-Insulated Metal-Enclosed Switchgear for Rated Voltages 72.5 kV and Above.<sup>1</sup>

IEEE Std 48-1990, IEEE Standard Test Procedures and Requirements for High-Voltage Alternating-Current Cable Terminations (ANSI).<sup>2</sup>

IEEE Std 575-1988, IEEE Guide for the Application of Sheath-Bonding Methods for Single-Conductor Cables and the Calculation of Induced Voltages and Currents in Cable Sheaths (ANSI).

IEEE Std C37.122-1993, IEEE Standard for Gas-Insulated Substations (ANSI).

IEEE Std C37.122.1-1993, IEEE Guide for Gas-Insulated Substations (ANSI).

## 3. Definitions

The definitions in this clause are applicable only to the subject treated in this guide. Figure 1 illustrates the parts of a cable connection assembly for gas-insulated substations that are defined in this clause.

**3.1 cable connection assembly:** The combination of the cable termination with the cable connection enclosure, GIS conductor end, and removable conductor link.

**3.2 cable connection enclosure:** The part of the GIS that surrounds the cable termination

<sup>1</sup>IEC publications are available from IEC Sales Department, Case Postale 131, 3, rue de Varembe, CH-1211, Genève 20, Switzerland/Suisse. IEC publications are also available in the United States from the Sales Department, American National Standards Institute, 11 West 42nd Street, 13th Floor, New York, NY 10036, USA.

<sup>2</sup>IEEE publications are available from the Institute of Electrical and Electronics Engineers, 445 Hoes Lane, P.O. Box 1331, Piscataway, NJ 08855-1331, USA.

**3.3 cable termination:** Parts assembled onto the end of the cable to provide the electrical and mechanical interface into the gas-insulated environment. Typically this includes a solid insulation barrier between the cable/cable fluid and the gas insulation of the GIS.

**3.4 conductor current connection interface:** The connection for transfer of conductor current from the GIS conductor to the cable termination

**3.5 GIS conductor end:** The end of the GIS high-voltage conductor inside the cable connection enclosure.

**3.6 removable conductor link:** A removable connector between the GIS conductor and the end of the cable termination.

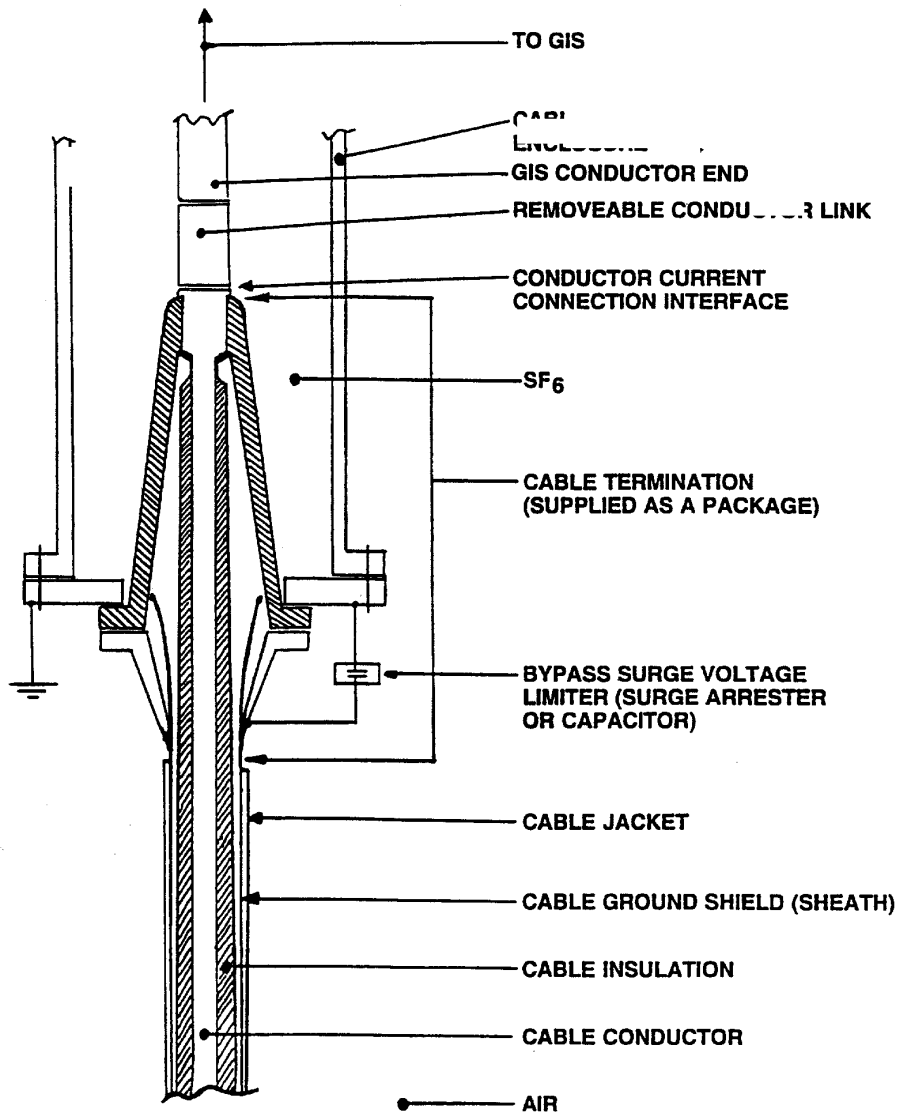
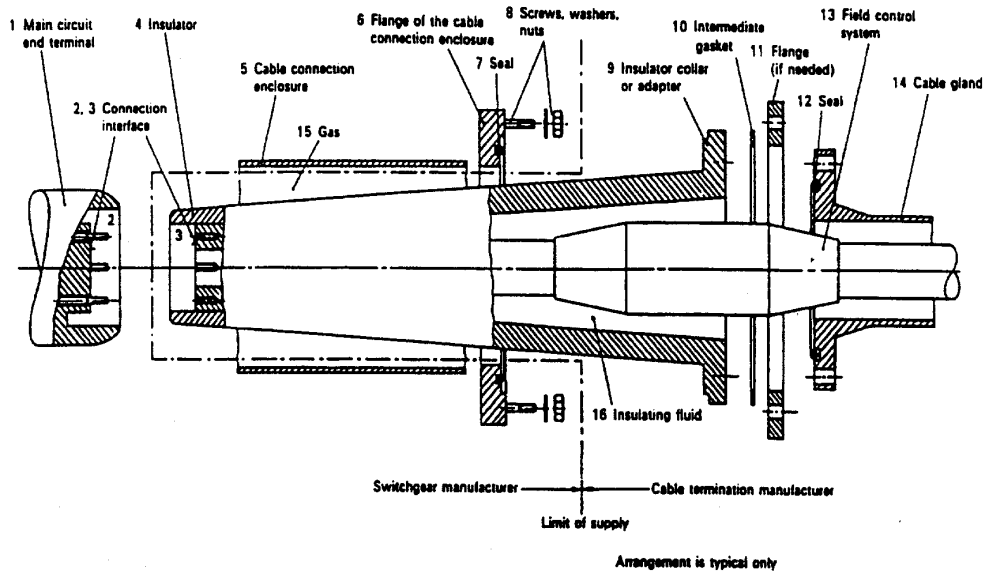

Figure 1—Parts of a cable connection assembly for gas-insulated substations



### 4. Limits of supply

The usual limits of supply for each party are shown in figure 2 for one type of construction frequently used for extruded dielectric cables, and in figure 3 for a type of construction frequently used for high-pressure fluid filled cables (HPFF). Similar limits of supply apply to self-contained fluid filled (SCFF) and low-pressure fluid filled (LPFF) cables.



Description	No.	Manufacturer	
		Switch gear	Cable termination
Main circuit end terminal	1	x	
Connection interface	2	x	
Connection interface	3		x
Insulator	4		x
Cable connection enclosure	5	x	
Flange	6	x	
Seal	7	x	
Screws, washers, nuts	8	x	
Adapter	9		x (if needed)
Gasket	10		x (if needed)
Flange	11		x (if needed)
Seal	12		x
Field control system	13		x
Cable gland	14		x
Gas	15	x	
Insulating fluid	16		x

Figure 2—Typical cable connection assembly for gas-insulated, metal-enclosed switchgear for rated voltages of 72.5 kV and above

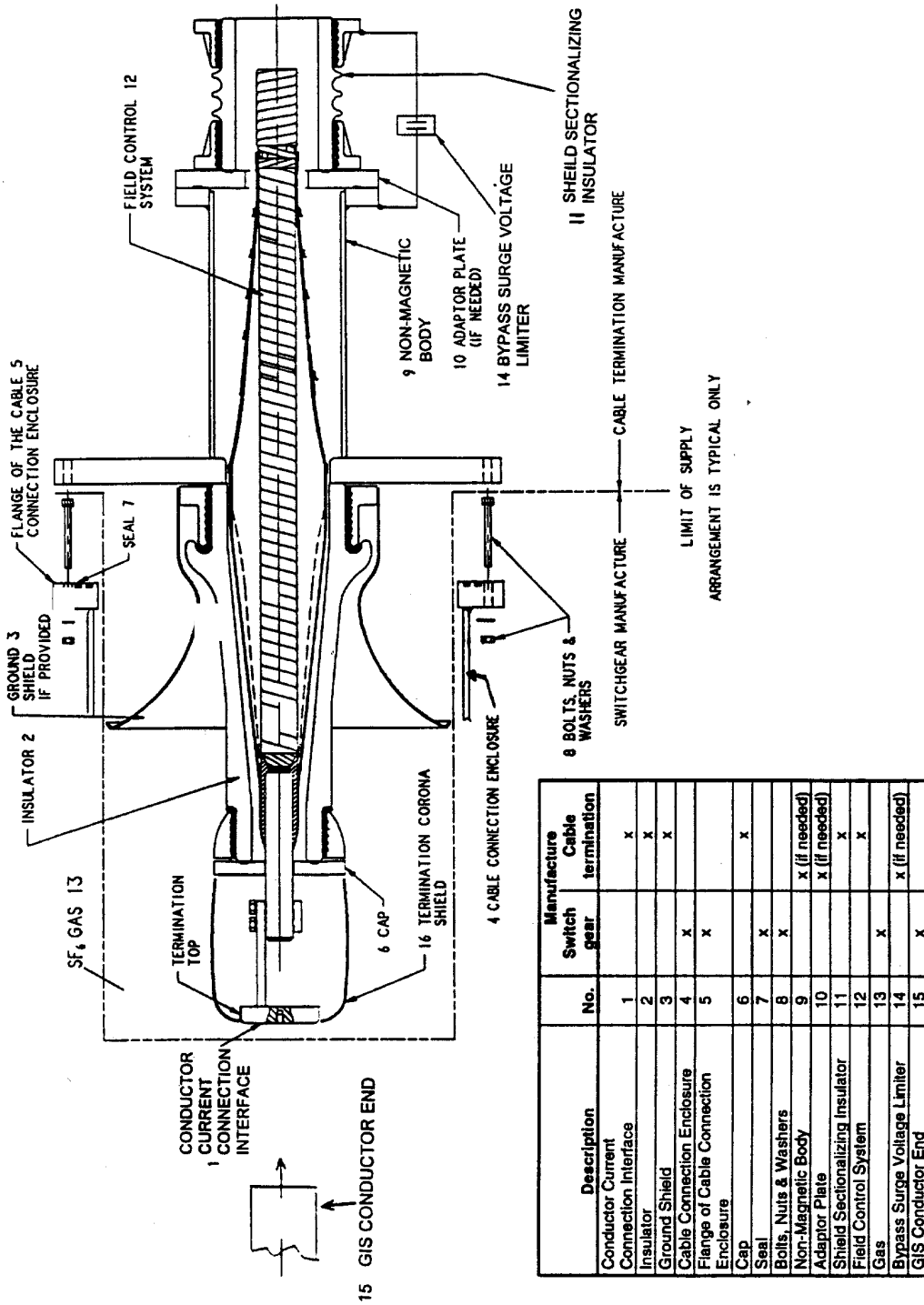
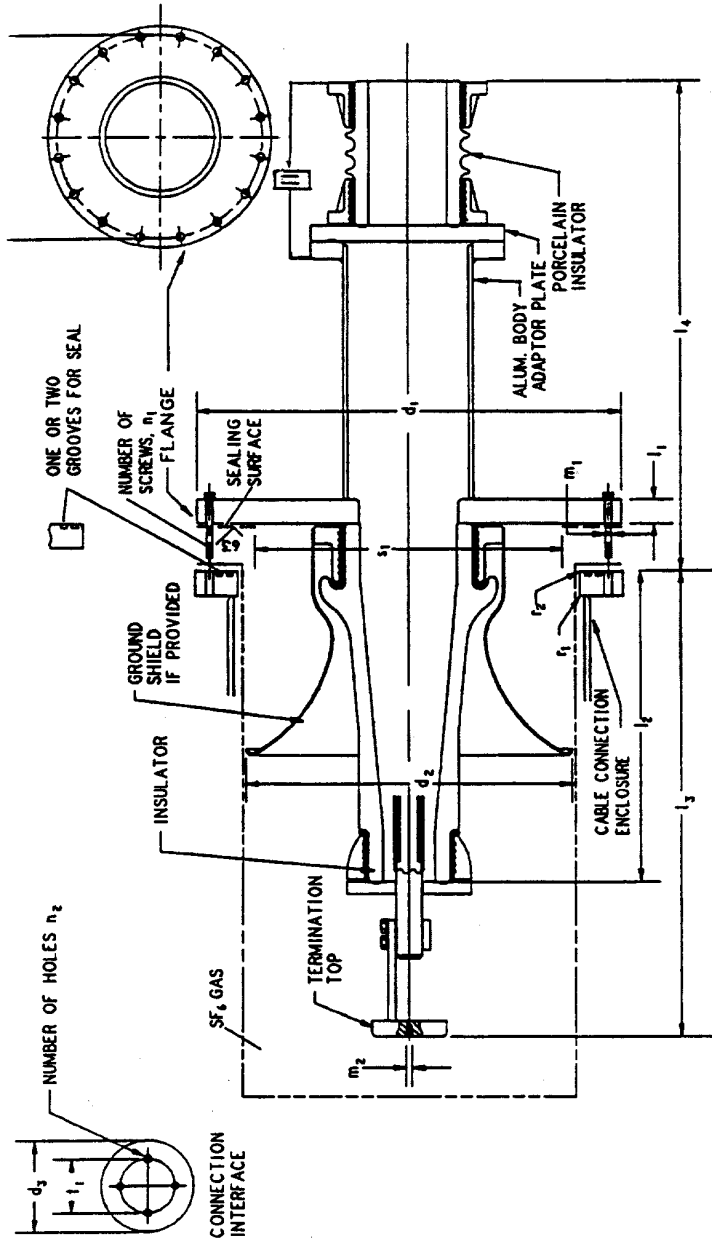

Figure 3—Limits of supply for specialized cable connection construction used for pipe-type HPFF cable





kV	d <sub>1</sub> max	d <sub>2</sub> max	d <sub>3</sub> max	l <sub>1</sub> max	l <sub>2</sub> max	l <sub>3</sub> max	l <sub>4</sub> max	n <sub>1</sub>	n <sub>2</sub>	m <sub>1</sub>	m <sub>2</sub>	r <sub>1</sub> min	r <sub>2</sub> min	s <sub>1</sub> max	l <sub>1</sub> (±0.15)	l <sub>2</sub> (±0.15)
69 to 138	470 (18.500)	368.3 (14.50)	90.5 (3.562)	38.1 (1.50)	614.3 (24.187)	938.2 (36.937)	970 (38.187)	16	4	1/2"-13	3/8"-16	9.98 (.393)	2.49 (.098)	330.2 (13)	(1.937)	(17.000)
230	724.7 (28.531)	574.6 (22.625)	155.6 (6.125)	50.8 (2.00)	766.7 (30.187)	1098.5 (43.250)	1098.5 (43.250)	24	6	5/8"-11	1/2"-13	9.98 (.393)	2.49 (.098)	533.4 (21)	(3.625)	(26.968)
345	892.2 (35.125)	698.5 (27.50)	155.6 (6.125)	50.8 (2.00)	768.4 (30.250)	1100.1 (43.312)	1098.5 (43.250)	24	6	5/8"-11	1/2"-13	9.98 (.393)	2.49 (.098)	660.4 (26)	(3.625)	(33.000)

Figure 5—Representative cable connection dimensions for specialized cable connection construction used for pipe-type HPFF cables

## 6. Ratings

The following should be specified and considered in design of the cable connection, and values should be chosen from IEEE Std 48-1990,<sup>3</sup> with due consideration being given to gas-insulated switchgear (GIS) ratings from IEEE Std C37.122-1993.

- Voltage—kV rms phase-to-phase
- Basic insulation level—kV peak
- Continuous current—A rms
- Short-time current—kA rms for 1 s or 3 s
- Peak short circuit current—kA peak
- Maximum dielectric fluid pressure for cable system—kPa
- Power frequency factory withstand voltage—kV rms phase-to-ground
- GIS power frequency field withstand voltage—kV rms phase-to-ground
- DC (or ac) cable test voltage—kV dc (or ac) phase-to-ground
- Field test voltage for cable or pipe coverings (cable jacket or corrosion protective pipe covering)

Of the preceding list items, *continuous current*, *short-time current*, *peak short circuit current*, and *maximum dielectric fluid pressure for cable system* are system dependent and should be referred to the cable termination manufacturer.

## 7. Temperature rise and conductor contact surfaces

The connection interface shown in figures 2 and 3 should be designed so that the conductor contact interface temperature shall not exceed 70 °C at the rated current of the cable. There should be no dependence on heat transfer from the GIS-conductor end to the cable.

Conductor contact interface surfaces, if aluminum, should be treated with a conductive plating or coating to ensure long term stability of current transfer. In all cases care should be taken to ensure a reliable contact and field measurement of resistance after assembly is recommended.

## 8. Gas pressure

For cable connections where the gas is SF<sub>6</sub>, the design pressure should not exceed 0.85 MPa absolute (108 lbf/in<sup>2</sup>). Dielectric-type tests should be done at the minimum operating pressure of the SF<sub>6</sub> gas as specified by table 1. Note that the GIS does not itself have to satisfy the minimum operating pressure applicable to the cable termination.

**Table 1—Gas-pressure limits for dielectric type test of cable terminations**

Range of rated voltages <i>U</i> kV rms phase-to-phase	Minimum SF <sub>6</sub> gas pressure (absolute) at 20 °C MPa	Minimum SF <sub>6</sub> gas pressure at 20 °C lbf/in <sup>2</sup>
72.5	0.10	0
100–170	0.30	29
245–300	0.35	36
362–550	0.40	43

NOTE—The gas pressures are intended as a test guideline for the manufacturer of the cable termination. Higher values are permissible, but should not exceed 0.85 MPa (108 lbf/in<sup>2</sup>). If a gas other than SF<sub>6</sub> is used, the minimum gas pressure should be chosen to give the same dielectric strength.

<sup>3</sup>Information on references can be found in clause 2.

## 9. Dielectric type test

### 9.1 Cable termination dielectric type test

The cable termination should be able to pass a dielectric-type test to the levels of IEEE Std 48-1990, with due consideration being given to GIS ratings from IEEE Std C37.122-1993. The tests may be done with simulated enclosures consisting of metal cylinders as appropriate for symmetrical single-phase or asymmetrical three-phases in one enclosure, as shown in figure 6.

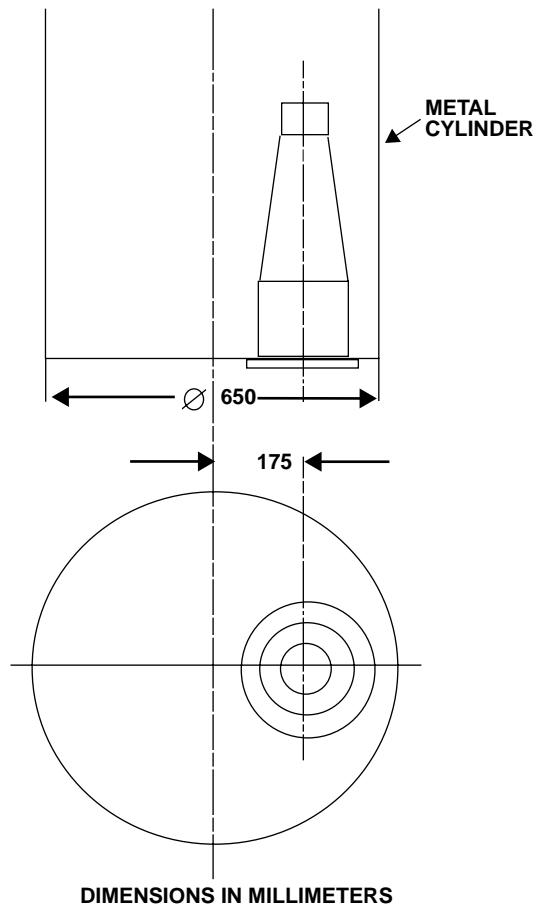

**Figure 6—Nonsymmetrical arrangement for dielectric tests of cable terminations of three-phase enclosure type, not recommended for pipe type cable systems**

An additional test shield may be added to shield the end of the cable termination if it does not electrically overlap the termination end in a way that would alter the electric field distribution of the cable termination itself.

### 9.2 Cable connection enclosure dielectric type test

The cable connection enclosure may be dielectric-type tested without the cable termination using an additional test shield on the GIS conductor end, but this shield should not alter the electric field distribution that will exist on the GIS parts with the cable termination in place.

### 9.3 Isolating gap

An isolating gap is needed between the GIS conductor end and the cable termination end to allow separate testing of the GIS and cable. This gap is usually provided by a removable conductor link and, if necessary,

shields on the ends of the GIS conductor and/or the cable termination end. No special dielectric-type tests are considered necessary for this condition since it is only present during field tests, and separate dielectric-type tests of the cable termination and cable termination enclosure demonstrate adequate withstands with suitable shields.

## 10. Mechanical force (short circuit and other)

For three phases in one enclosure, the design should recognize the short-circuit transverse forces between conductors. In this case the maximum additional transverse force to be accommodated by the cable termination end should not exceed 5 kN. For single-phase cable connections, the transverse force applied to the cable termination end should not exceed 2 kN.

The GIS manufacturer should be responsible to ensure that specified forces are not exceeded, and that thermal expansion and alignment movement of the cable connection assembly does not exceed acceptable limits.

The cable termination manufacturer should be responsible for proper restraint of cable forces acting on the cable terminations.

## 11. Cable connection support structures

The GIS manufacturer should be responsible for proper support of the cable termination enclosure and the cable termination itself, taking into account the forces expected to be transferred from the cable to the cable termination and hence to the cable termination enclosure. The GIS manufacturer should be responsible for coordination with the cable termination manufacturer to assure proper separation and proper orientation between the two supports and adequate clearances below the lower support (if required).

## 12. Grounding

The cable connection enclosure should be electrically connected to the GIS enclosure for grounding. The cable termination should include an electrically insulating shield sectionalizing insulator between the parts electrically connected to the cable termination enclosure and the cable's metallic ground shield and/or pipe. Typical locations for this are shown physically in figure 7 and schematically in figure 8. This shield sectionalizing insulator allows separate grounding and cathodic protection of the cable's ground shields and/or pipe and a cable jacket integrity test. It can also be used to limit circulating currents in the cable's metallic shield and/or pipe.

In some cases the shield sectionalizing insulator may not be needed, or may be needed for test only, in which case the cable termination manufacturer should supply the shorting provisions.

GIS switching transients with very fast rise times may cause short duration overvoltages between cable connection parts that are separately grounded. Adequate electrical insulation must be provided between such parts both internally and externally. Bypass surge voltage limiters (metal-oxide surge arresters or capacitors) are required if a shield sectionalizing insulator exists. Since the transients have very short rise times (in the nanosecond range), the bypass surge voltage limiters need to be mounted very close to the gap to be protected and connected by short, low-impedance leads. Shield sectionalizing insulators are subjected to overvoltages for several reasons as described in IEEE C27.122.1-1993 and in IEEE Std 575-1988, and as in [B4], [B2], and [B3].<sup>4</sup>

NOTE—GIS manufacturer should participate in specifying bypass surge voltage limiter, but they should be supplied by the cable termination manufacturer.

<sup>4</sup>The numbers in brackets preceded by the letter B correspond to those of the bibliography in clause 17.

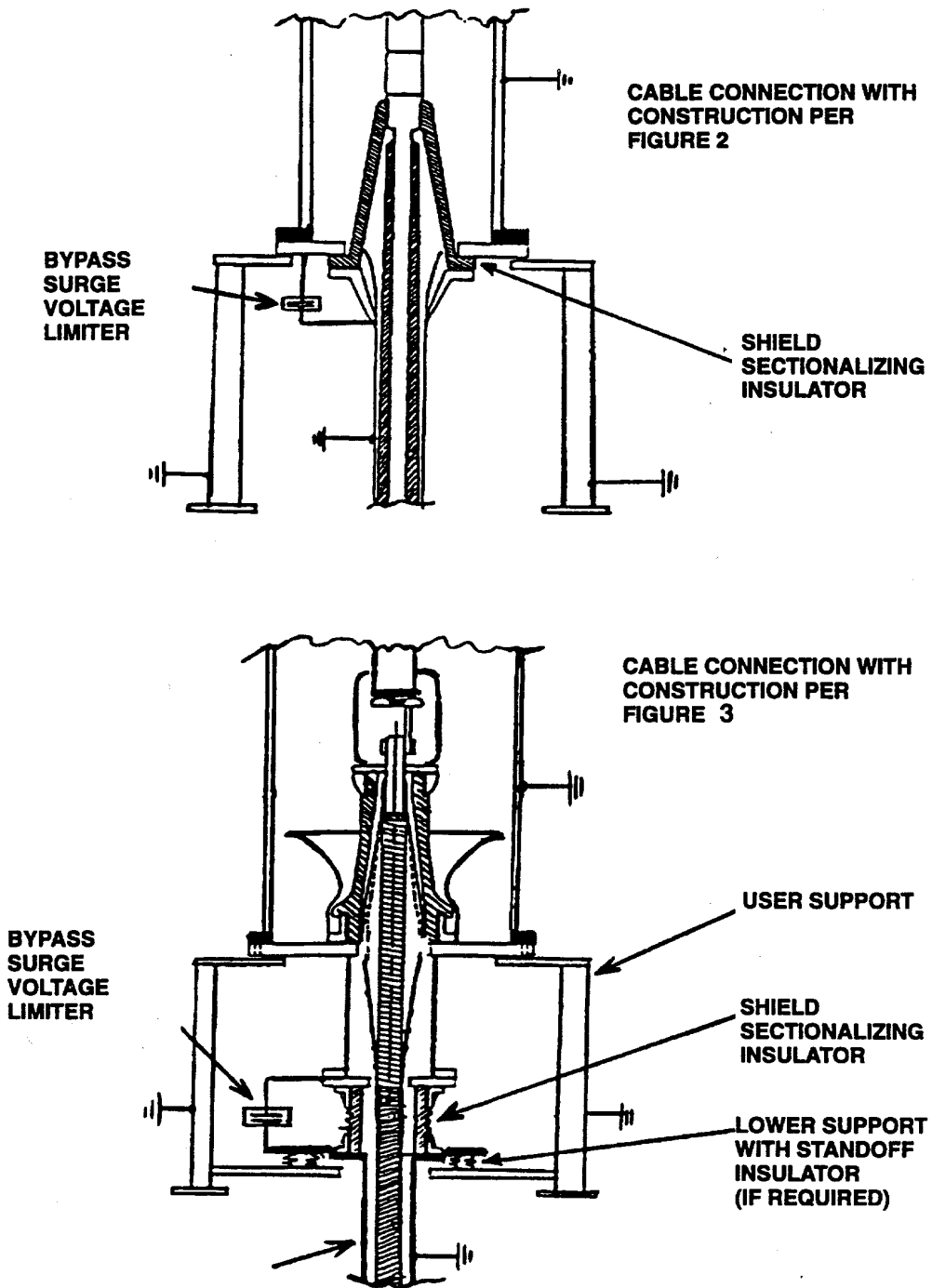

Figure 7—Typical physical locations of shield sectionalizing insulator between GIS and cable shield, sheath, or pipe—grounding and bypass surge voltage limiter



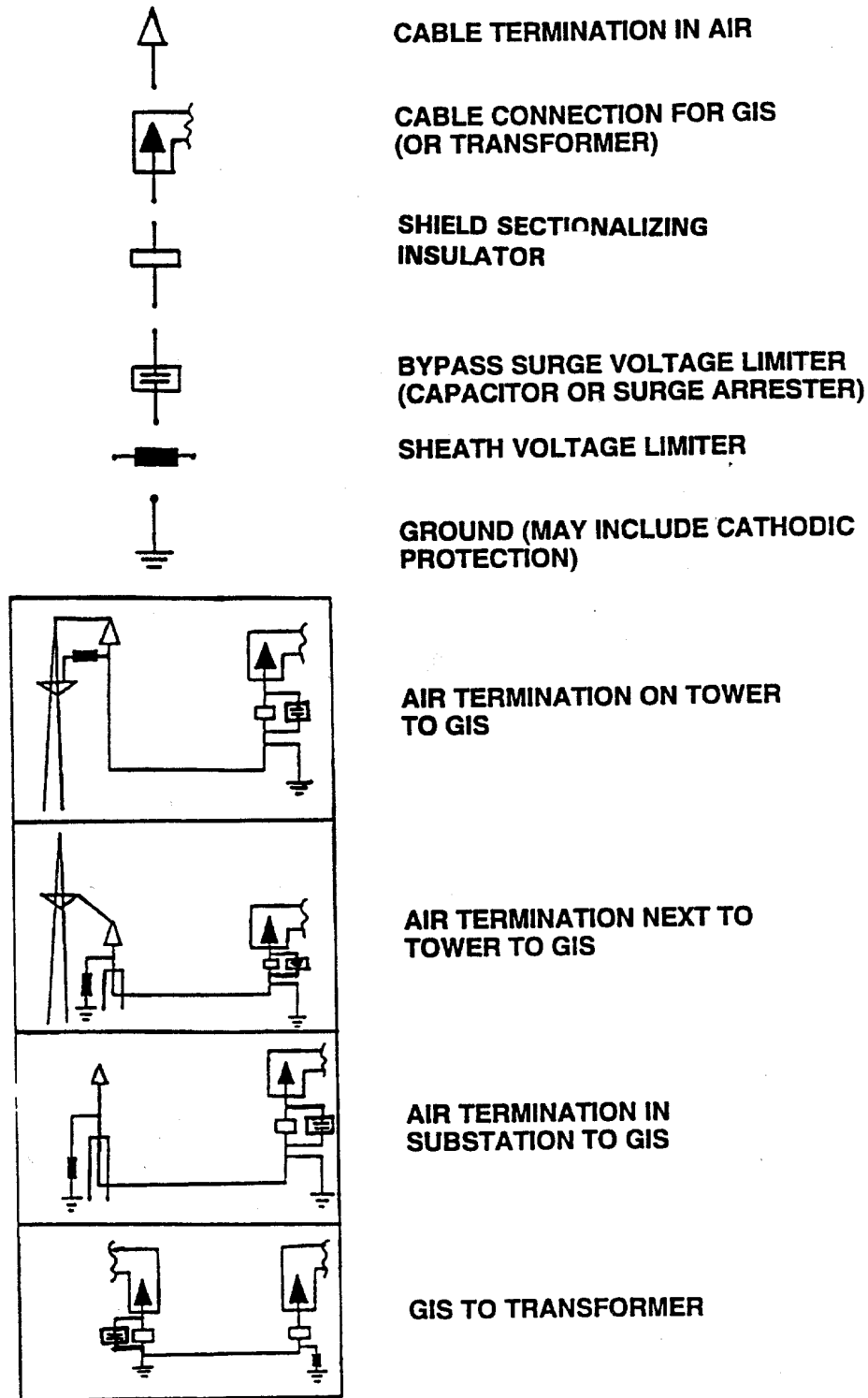

Figure 8—Typical schematic locations of shield sectionalizing insulator between GIS and cable shield, sheath, or pipe—grounding and bypass surge voltage limiter

## 13. Installation

The GIS manufacturer should be responsible for coordinating access provisions and for ensuring that fit is achieved within the usual design tolerances and adjustments of the various parts. This will require review of the cable installation procedure and is especially critical if the cable (or a rigid pipe) is installed prior to the GIS.

Unless otherwise specified, the GIS manufacturer and/or GIS installer is not responsible for installing the cable termination on the cable. Normally, the GIS is installed and tested prior to the cable termination being installed. In this case the GIS manufacturer should supply a suitable permanent cap for the opening in the cable connection enclosure that will later be used for the cable termination. This cap should allow complete GIS testing. The cable connection enclosure may have to be removed to accommodate installation of the cable termination.

## 14. Field tests

### 14.1 Dielectric field tests

To allow separate testing of GIS and cable, the cable connection should include the following:

- a) Removable conductor link—removable connector between cable termination end and GIS conductor end, of suitable length, and shielded so that voltage may be independently applied to either the GIS or the cable. The end of the part not being tested should be grounded.
- b) Any special tools (e.g., shields, grounding connectors for use inside the cable termination enclosure) needed for setting up a suitable condition for test, provided by the GIS manufacturer.
- c) Test bushing—when the field test voltage must be applied at the cable connection, the GIS manufacturer should supply suitable test bushing or bushings. This may be the case when the GIS has no SF<sub>6</sub>-air bushings and the cable is terminated at its other end in an enclosed manner.
- d) Detailed instructions for removal and replacement of the conductor link, including a checklist of steps and detailed descriptions of any tools needed, provided by the GIS manufacturer.

### 14.2 Other field tests

Other tests as appropriate for either the GIS or the cable may be performed.

## 15. Operation and maintenance

The practice of reclosing should be avoided when attempting to locate faults internal to the GIS, cable connection enclosure, or cable. To facilitate fault location, current transformers may be required at the cable connections.

The gas pressure (density) is monitored as a part of the GIS alarms and controls. The cable fluids (if any) are monitored per cable and/or cable termination according to the manufacturer's requirements.

Other devices (high-voltage surge arrester, voltage transformer, ground switch, current transformers, etc.) are sometimes installed in the same GIS enclosure as the cable termination. If any of these devices need to be removed for access or test, the GIS manufacturer should provide suitable secure covers for the openings left by removal of the device.

## 16. Special accessories

### 16.1 Vent and sample valve for fluid filled cables

The user may specify vent and sample valve at the high voltage end of the cable termination.

### 16.2 Detection of cable fluid leaks inside cable termination enclosure

For high-pressure fluid filled cables it may be appropriate to provide for an alarm if a significant amount of cable fluid leaks into the cable termination enclosure. The fluid will collect at the bottom of the cable termination enclosure where a sensor can detect the presence of the cable fluid.

### 16.3 Viewports

For especially critical applications or difficult working site conditions, a viewport on the cable termination enclosure may be specified to allow visual inspection of the internal connection.

## 17. Bibliography

[B1] Arkell, C. A., Galloway, S. J., and Gregory, B., "Supertension Cable Terminations For Metalclad SF<sub>6</sub> Insulated Substations," IEEE PES 1981 Transmission and Distribution Conference and Exposition, Minneapolis, MN, Apr. 1, 1981, Paper no. 81 TD 689-9; *Transactions on Power Apparatus and Systems*, vol. PAS-101, no. 5, pp. 1021-1029, May 1982.

[B2] CIGRE WG 21.07, "Design of Specially Bonded Cable Systems," Part I, *Electra*, no. 28, pp. 55-81; Part II, *Electra*, no. 47, pp. 61-86; Errata, *Electra*, no. 48, p. 73.

[B3] CIGRE WG 23.10, "Earthing of GIS—An Application Guide," *Electra*, No. 151, pp. 31-51, Dec. 1993.

[B4] Fujimoto, N., Croall, S. J., and Foty, S. M., "Techniques For the Protection of Gas-Insulated Substation to Cable Interfaces," IEEE Power Engineering Society Summer Meeting, San Francisco, 1987, Paper no. 87 SM 530-9, *Trans-PWRD*, vol. 3, no. 4, pp. 1650-1655, Oct. 1988.

[B5] Fujimoto, N., "Practical Considerations in Protecting Gas-Insulated Substation to Cable Interfaces," CEA Spring Meeting, Mar. 1987, Vancouver, B. C.

[B6] IEC Publication 517 (1990), Gas-Insulated Metal-Enclosed Switchgear for Rated Voltages of 72.5 kV and Above.

[B7] Ishikawa, M., Oh-hashii, N., Ogawa, Y., Ikeda, M., Miyamoto, H., and Shinagawa, J., "An approach to the suppression of sheath surge induced by switching surges in a GIS/power cable connection system," *IEEE Transactions on Power Apparatus and Systems*, vol. PAS-100, no. 2, pp. 528-538, Feb. 1981.

[B8] *Underground Transmission Systems Reference Book*, 1992, Electric Power Research Institute (EPRI), TR-101670, Research Project 7909-01, EPRI Distribution Center, 207 Coggins Drive, P.O. Box 23205, Pleasant Hill, CA 94523.