

Recognized as an
American National Standard (ANSI)

IEEE Std 399-1997

IEEE Recommended Practice for Industrial and Commercial Power Systems Analysis

Sponsor

**Power Systems Engineering Committee
of the
Industrial and Commercial Power Systems Department
of the
IEEE Industry Applications Society**

Approved 16 September 1997

IEEE Standards Board

Approved 28 April 1998

American National Standards Institute

Abstract: This Recommended Practice is a reference source for engineers involved in industrial and commercial power systems analysis. It contains a thorough analysis of the power system data required, and the techniques most commonly used in computer-aided analysis, in order to perform specific power system studies of the following: short-circuit, load flow, motor-starting, cable ampacity, stability, harmonic analysis, switching transient, reliability, ground mat, protective coordination, dc auxiliary power system, and power system modeling.

Keywords: cable ampacity, dc power system studies, ground mat studies, harmonic analysis, load flow studies, motor-starting studies, power system analysis, power system modeling, power system studies, protective coordination studies, reliability studies, short-circuit studies, stability studies, switching transient studies.

Grateful acknowledgment is made to the following organization for having granted permission to reprint illustrations in this document as listed below:

The General Electric Company, Schenectady, NY, for **Figures 16-2, 16-4, 16-6, and 16-7.**

First Printing
August 1998
SH94571

The Institute of Electrical and Electronics Engineers, Inc.
345 East 47th Street, New York, NY 10017-2394, USA

Copyright © 1998 by the Institute of Electrical and Electronics Engineers, Inc.
All rights reserved. Published 1998. Printed in the United States of America

ISBN 1-55937-968-5

No part of this publication may be reproduced in any form, in an electronic retrieval system or otherwise, without the prior written permission of the publisher.

IEEE Standards documents are developed within the Technical Committees of the IEEE Societies and the Standards Coordinating Committees of the IEEE Standards Board. Members of the committees serve voluntarily and without compensation. They are not necessarily members of the Institute. The standards developed within IEEE represent a consensus of the broad expertise on the subject within the Institute as well as those activities outside of IEEE that have expressed an interest in participating in the development of the standard.

Use of an IEEE Standard is wholly voluntary. The existence of an IEEE Standard does not imply that there are no other ways to produce, test, measure, purchase, market, or provide other goods and services related to the scope of the IEEE Standard. Furthermore, the viewpoint expressed at the time a standard is approved and issued is subject to change brought about through developments in the state of the art and comments received from users of the standard. Every IEEE Standard is subjected to review at least every five years for revision or reaffirmation. When a document is more than five years old and has not been reaffirmed, it is reasonable to conclude that its contents, although still of some value, do not wholly reflect the present state of the art. Users are cautioned to check to determine that they have the latest edition of any IEEE Standard.

Comments for revision of IEEE Standards are welcome from any interested party, regardless of membership affiliation with IEEE. Suggestions for changes in documents should be in the form of a proposed change of text, together with appropriate supporting comments.

Interpretations: Occasionally questions may arise regarding the meaning of portions of standards as they relate to specific applications. When the need for interpretations is brought to the attention of IEEE, the Institute will initiate action to prepare appropriate responses. Since IEEE Standards represent a consensus of all concerned interests, it is important to ensure that any interpretation has also received the concurrence of a balance of interests. For this reason IEEE and the members of its technical committees are not able to provide an instant response to interpretation requests except in those cases where the matter has previously received formal consideration.

Comments on standards and requests for interpretations should be addressed to:

Secretary, IEEE Standards Board
445 Hoes Lane
P.O. Box 1331
Piscataway, NJ 08855-1331
USA

Note: Attention is called to the possibility that implementation of this standard may require use of subject matter covered by patent rights. By publication of this standard, no position is taken with respect to the existence or validity of any patent rights in connection therewith. The IEEE shall not be responsible for identifying patents for which a license may be required by an IEEE standard or for conducting inquiries into the legal validity or scope of those patents that are brought to its attention.

Authorization to photocopy portions of any individual standard for internal or personal use is granted by the Institute of Electrical and Electronics Engineers, Inc., provided that the appropriate fee is paid to Copyright Clearance Center. To arrange for payment of licensing fee, please contact Copyright Clearance Center, Customer Service, 222 Rosewood Drive, Danvers, MA 01923 USA; (508) 750-8400. Permission to photocopy portions of any individual standard for educational classroom use can also be obtained through the Copyright Clearance Center.

Introduction

(This introduction is not a part of IEEE Std 399-1997, IEEE Recommended Practice for Industrial and Commercial Power Systems Analysis.)

This Recommended Practice, commonly known as the “Brown Book,” is intended as a practical, general treatise on power system analysis theory and as an engineer’s reference source on the techniques that are most commonly applied to the computer-aided analysis of electric power systems in industrial plants and commercial buildings. The Brown Book is a useful supplement to several other power system analysis texts that appear in the references and bibliography subclauses of the various chapters of this book. The Brown Book is both complementary and supplementary to the rest of the Color Book series.

One new and important chapter has been added: Chapter 16, entitled “DC auxiliary power system analysis.” All the other chapters in this new edition have been revised and updated—in some cases quite substantially—to reflect current technology.

To many members of the working group who wrote and developed this Recommended Practice, the Brown Book has become a true labor of love. The dedication and support of each individual member is clearly evident in every chapter of the Brown Book. These individuals deserve our many thanks for their excellent contributions.

The Brown Book Working Group for the 1997 edition had the following membership:

L. Guy Jackson, Chair

- Chapter 1: Introduction—**L. Guy Jackson, Chair**; George A. Terry
- Chapter 2: Applications of power system analysis—**L. Guy Jackson, Chair**;
George A. Terry
- Chapter 3: Analytical procedures—**M. Shan Griffith, Chair**; Anthony J. Rodolakis
- Chapter 4: System modeling—**Stephen S. Miller, Co-Chair**; **Mark Halpin, Co-Chair**;
Matt McBurnett; Anthony J. Rodolakis; Michael S. Tucker
- Chapter 5: Computer solutions and systems—**Glenn E. Word, Chair**; Anthony J. Rodolakis
- Chapter 6: Load flow studies—**Chet E. Davis, Co-Chair**; **James W. Feltes, Co-Chair**;
Mark Halpin; Anthony J. Rodolakis
- Chapter 7: Short-circuit studies—**Anthony J. Rodolakis, Chair**; William M. Hall;
Mark Halpin; Michael E. Lick; Matt McBurnett; Conrad St. Pierre
- Chapter 8: Stability studies—**Wei-Jen Lee, Co-Chair**; **Mark Halpin, Co-Chair**;
Matt McBurnett; Anthony J. Rodolakis
- Chapter 9: Motor-starting studies—**M. Shan Griffith, Co-Chair**; **Mike Aimone, Co-Chair**;
Anthony J. Rodolakis
- Chapter 10: Harmonic analysis studies—**Suresh C. Kapoor, Chair**; M. Shan Griffith;
Mark Halpin
- Chapter 11: Switching transient studies—**Carlos B. Pinheiro, Chair**
- Chapter 12: Reliability studies—**Michael R. Albright, Chair**
- Chapter 13: Cable ampacity studies—**Farrokh Shokooh, Chair**
- Chapter 14: Ground mat studies—**M. Shan Griffith, Chair**; Anthony J. Rodolakis
- Chapter 15: Coordination studies—**A. Elizabeth Ronat, Chair**; Mike Aimone;
Michael E. Lick; John F. Witte
- Chapter 16: DC auxiliary power system analysis—**Kenneth Fleishcher, Co-Chair**;
Scott Munnings, Co-Chair; Ajkit K. Hiranandani; Gene A. Poletto

Others who contributed to the development of this document are as follows:

J. J. Dia	A. D. Patton	George W. Walsh
C. R. Heising	David Shipp	Erzhuan Zhou

The following persons were on the balloting committee:

Mike A. Aimone
Michael R. Albright
Robert J. Beaker
Reuben F. Burch IV
Chet Davis
James W. Feltes
Landis H. Floyd
Jerry M. Frank
Dan Goldberg
M. Shan Griffith
William M. Hall
Mark S. Halpin
L. Guy Jackson
Suresh C. Kapoor

Don O. Koval
Wei-Jen Lee
Michael E. Lick
Matt McBurnett
Richard H. McFadden
Reg Mendis
Steve S. Miller
Daleep Mohla
William J. Moylan
R. Scott Munnings
Andrew T. Morris
Ed Palko
Gene A. Poletto

Brian Rener
Rasheek Rifaat
Milton D. Robinson
Anthony Rodolakis
A. Elizabeth Ronat
Donald R. Ruthman
Vincent Saporita
Lynn F. Saunders
Stan Shilling
David Shipp
Farrokh Shokooh
Conrad R. St. Pierre
Erzhuan Zhou
Donald W. Zipse

When the IEEE Standards Board approved this standard on 16 September 1997, it had the following membership:

Donald C. Loughry, *Chair*

Richard J. Holleman, *Vice Chair*

Andrew G. Salem, *Secretary*

Clyde R. Camp
Stephen L. Diamond
Harold E. Epstein
Donald C. Fleckenstein
Jay Forster*
Thomas F. Garrity
Donald N. Heirman
Jim Isaak
Ben C. Johnson

Lowell Johnson
Robert Kenelly
E.G. "Al" Kiener
Joseph L. Koepfinger*
Stephen R. Lambert
Lawrence V. McCall
L. Bruce McClung
Marco W. Migliaro

Louis-François Pau
Gerald H. Peterson
John W. Pope
Jose R. Ramos
Ronald H. Reimer
Ingo Rüsçh
John S. Ryan
Chee Kiow Tan
Howard L. Wolfman

*Member Emeritus

Also included are the following nonvoting IEEE Standards Board liaisons:

Satish K. Aggarwal
Alan H. Cookson

Paula M. Kelty
IEEE Standards Project Editor

Contents

Chapter 1	
Overview.....	1
1.1 Scope and general information	1
1.2 History of power system studies	1
1.3 Applying power system analysis techniques to industrial and commercial power systems	2
1.4 Purposes of this Recommended Practice	2
1.5 References	5
Chapter 2	
Applications of power system analysis.....	7
2.1 Introduction.....	7
2.2 Load flow analysis	7
2.3 Short-circuit analysis.....	8
2.4 Stability analysis	8
2.5 Motor-starting analysis	8
2.6 Harmonic analysis.....	9
2.7 Switching transients analysis	10
2.8 Reliability analysis	10
2.9 Cable ampacity analysis.....	10
2.10 Ground mat analysis.....	11
2.11 Protective device coordination analysis.....	11
2.12 DC auxiliary power system analysis.....	12
Chapter 3	
Analytical procedures	13
3.1 Introduction.....	13
3.2 Fundamentals	14
3.3 Bibliography.....	40
Chapter 4	
System modeling.....	43
4.1 Introduction.....	43
4.2 Modeling	43
4.3 Review of basics	44
4.4 Power network solution	49
4.5 Impedance diagram	53
4.6 Extent of the model	54
4.7 Models of branch elements	55
4.8 Power system data development	71
4.9 Models of bus elements.....	80

4.10	References	99
4.11	Bibliography.....	100
Chapter 5		
	Computer solutions and systems.....	103
5.1	Introduction.....	103
5.2	Numerical solution techniques	104
5.3	Computer systems	122
5.4	Bibliography.....	129
Chapter 6		
	Load flow studies.....	133
6.1	Introduction.....	133
6.2	System representation	134
6.3	Input data.....	137
6.4	Load flow solution methods.....	140
6.5	Load flow analysis	149
6.6	Load flow study example.....	151
6.7	Load flow programs	162
6.8	Conclusions.....	162
Chapter 7		
	Short-circuit studies	165
7.1	Introduction and scope	165
7.2	Extent and requirements of short-circuit studies.....	166
7.3	System modeling and computational techniques	168
7.4	Fault analysis according to industry standards	172
7.5	Factors affecting the accuracy of short-circuit studies.....	179
7.6	Computer solutions	182
7.7	Example	187
7.8	References	203
7.9	Bibliography.....	206
Chapter 8		
	Stability studies.....	209
8.1	Introduction.....	209
8.2	Stability fundamentals.....	209
8.3	Problems caused by instability.....	216
8.4	System disturbances that can cause instability.....	216
8.5	Solutions to stability problems.....	217
8.6	System stability analysis	218
8.7	Stability studies of industrial power systems	223
8.8	Summary and conclusions	228
8.9	Bibliography	229

Chapter 9	
Motor-starting studies	231
9.1 Introduction	231
9.2 Need for motor-starting studies.....	231
9.3 Recommendations	235
9.4 Types of studies	237
9.5 Data requirements	238
9.6 Solution procedures and examples.....	241
9.7 Summary	259
9.8 References	263
9.9 Bibliography.....	263
Chapter 10	
Harmonic analysis studies.....	265
10.1 Introduction	265
10.2 Background	266
10.3 Purpose of harmonic study.....	267
10.4 General theory	268
10.5 System modeling	276
10.6 Example solutions	290
10.7 Remedial measures	302
10.8 Harmonic standards.....	307
10.9 References	309
10.10 Bibliography.....	309
Chapter 11	
Switching transient studies	313
11.1 Power system switching transients	313
11.2 Switching transient studies.....	338
11.3 Switching transients—field measurements.....	359
11.4 Typical circuit parameters for transient studies	363
11.5 References	367
11.6 Bibliography.....	367
Chapter 12	
Reliability studies.....	375
12.2 Definitions.....	375
12.3 System reliability indexes	377
12.4 Data needed for system reliability evaluations	377
12.5 Method for system reliability evaluation	378
12.6 References	380

Chapter 13	
Cable ampacity studies	383
13.1 Introduction	383
13.2 Heat flow analysis	384
13.3 Application of computer program	386
13.4 Ampacity adjustment factors	388
13.5 Example	399
13.6 Conclusion	403
13.7 References	404
13.8 Bibliography	404
Chapter 14	
Ground mat studies	407
14.1 Introduction	407
14.2 Justification for ground mat studies	407
14.3 Modeling the human body	407
14.4 Traditional analysis of the ground mat	410
14.5 Advanced grid modeling	415
14.6 Benchmark problems	418
14.7 Input/output techniques	420
14.8 Sample problem	420
14.9 Conclusion	420
14.10 Reference	423
14.11 Bibliography	424
Chapter 15	
Coordination studies	429
15.1 Introduction	429
15.2 Basics of coordination	430
15.3 Computer programs for coordination	435
15.4 Common structure for computer programs	436
15.5 How to make use of coordination software	441
15.6 Verifying the results	443
15.7 Equipment needs	443
15.8 Conclusion	444
15.9 Bibliography	444
Chapter 16	
DC auxiliary power system analysis	445
16.1 Introduction	445
16.2 Purpose of the recommended practice	445
16.3 Application of dc power system analysis	445
16.4 Analytical procedures	446

16.5 System modeling 446
16.6 Load flow/voltage drop studies 461
16.7 Short-circuit studies 464
16.8 International guidance on dc short-circuit calculations 466
16.9 Bibliography 466
Index 469

IEEE Recommended Practice for Industrial and Commercial Power Systems Analysis

Chapter 1 Overview

1.1 Scope and general information

This Recommended Practice, commonly known as the IEEE Brown Book, is published by the Institute of Electrical and Electronics Engineers, Inc. (IEEE) as a reference source to give plant engineers a better understanding of the purpose for and techniques involved in power system studies. The IEEE Brown Book can also be a helpful reference source for system and data acquisition for engineering consultants performing necessary studies prior to designing a new system or expanding an existing power system. This Recommended Practice will help ensure high standards of power system reliability and maximize the utilization of capital investment.

The IEEE Brown Book emphasizes up-to-date techniques in system studies that are most applicable to industrial and commercial power systems. It complements the other IEEE Color Books, and is intended to be used in conjunction with, not as a replacement for, the many excellent texts available in this field.

The IEEE Brown Book was prepared on a voluntary basis by engineers and designers functioning as a Working Group within the IEEE, under the Industrial and Commercial Power Systems Department of the Industry Applications Society.

1.2 History of power system studies

The planning, design, and operation of a power system requires continual and comprehensive analyses to evaluate current system performance and to establish the effectiveness of alternative plans for system expansion.

The computational work to determine power flows and voltage levels resulting from a single operating condition for even a small network is all but insurmountable if performed by manual methods. The need for computational aids led to the design of a special purpose analog computer (ac network analyzer) as early as 1929. It provided the ability to determine flows and voltages during normal and emergency conditions and to study the transient behavior of the system resulting from fault conditions and switching operations.

The earliest application of digital computers to power system problems dates back to the late 1940s. Most of the early applications were limited in scope because of the small capacity of the punched card calculators in use during that period. Large-scale digital computers became

available in the mid-1950s, and the initial success of load flow programs led to the development of programs for short-circuit and stability calculations.

Today, the digital computer is an indispensable tool in power system planning, in which it is necessary to predict future growth and simulate day-to-day operations over periods of twenty years or more.

1.3 Applying power system analysis techniques to industrial and commercial power systems

As computer technology has advanced, so has the complexity of industrial and commercial power systems. These power systems have grown in recent decades with capacities far exceeding that of a small electric utility system.

Today's intensely competitive business environment forces plant or building management personnel to be very aware of the total owning cost of the power distribution system. Therefore, they demand assurances of maximum return on all capital investments in the power system. The use of digital computers makes it possible to study the performance of proposed and actual systems under many operating conditions. Answers to many questions regarding impact of expansion on the system, short-circuit capacity, stability, load distribution, etc., can be intelligently and economically obtained.

1.4 Purposes of this Recommended Practice

1.4.1 Why a study?

As is stated in Chapter 2, the planning, design, and operation of industrial and commercial power systems require several studies to assist in the evaluation of the initial and future system performance, system reliability, safety, and the ability to grow with production and/or operating requirements. The studies most likely to be needed are load flow studies, cable ampacity studies, short-circuit studies, coordination studies, stability studies, and routine motor-starting studies. Additional studies relating to switching transients, reliability, grounding, harmonics, and special motor-starting considerations may also be required. The engineer in charge of system design must decide which studies are needed to ensure that the system will operate safely, economically, and efficiently over the expected life of the system.

A brief summary of these studies is presented in Chapter 2, along with a discussion pertaining to data collection and preparation of the data files required to perform the desired study on a digital computer.

1.4.2 How to prepare for a power system study

For a plant engineer to solve a power system analysis problem, he or she must be thoroughly familiar with the fundamentals of power electrical engineering. He or she can then analyze

the problem, prepare the necessary equivalent circuits, and obtain appropriate system data before using a computer program to perform repetitive calculations. Failure to use a valid analytical procedure to establish a sound basic approach to the problem could lead to disastrous consequences in both the design and operation of a system. Furthermore, a basic understanding of power engineering is essential to correctly interpret the results of computer calculations. It is important to emphasize the need for a thorough foundation and base of experience in power system engineering in addition to modern, effective computer software. Power system analysis engineering software is an excellent tool for studying power systems, but it cannot be used as a substitute for knowledge and experience. Chapter 3 offers an excellent review of the most essential fundamentals in a system study.

To set up a computer program for system analysis, certain basic data must be gathered with accuracy and proper presentation. The extent of system representation, restrictions in terms of nodes (buses) and branches (lines and transformers), balanced three-phase network and single-line diagram, impedance diagram, etc., are all important inputs to a meaningful system study. Chapter 4 deals with system modeling and data requirements to illustrate how these basic data for a study can be properly prepared or organized.

Once the basic preparations are completed, the next step is to look for an actual computer program. Programs are available—written for personal computers (PCs)—that allow in-house calculation for the studies outlined in this standard. Chapter 5 discusses basic computation methods, various types of computer systems and their requirements, and availability of commercial computing services and their capabilities.

1.4.3 The most common system studies

The following chapters address the most common studies for the design or operation of an industrial or commercial power system:

- Chapter 6, Load flow studies
- Chapter 7, Short-circuit studies
- Chapter 8, Stability studies
- Chapter 9, Motor-starting studies
- Chapter 10, Harmonic analysis studies
- Chapter 11, Switching transient studies
- Chapter 12, Reliability studies
- Chapter 13, Cable ampacity studies
- Chapter 14, Ground mat studies
- Chapter 15, Coordination studies
- Chapter 16, DC auxiliary power system analysis

The purpose of each study and what can be achieved by it are briefly explained in each chapter.

Figure 1-1 is a typical composite single-line diagram for a large industrial power system that is used in Chapters 6 through 15.

After studying these chapters, an engineer should be better equipped to prepare necessary data and criteria for a specific computer study. The study can be performed in-house or by an outside consultant. There is a growing number of consulting firms that specialize in performing system studies at a reasonable cost.

Studying these chapters will provide the basic understanding of the studies needed to coordinate the data and criteria for specific studies and will also serve as a reference to those analysts for whom studies are a principal activity.

1.5 References

This chapter shall be used in conjunction with the following publications:

IEEE Std 141-1993, IEEE Recommended Practice for Electric Power Distribution for Industrial Plants (IEEE Red Book).¹

IEEE Std 142-1991, IEEE Recommended Practice for Grounding of Industrial and Commercial Power Systems (IEEE Green Book).

IEEE Std 241-1990, IEEE Recommended Practice for Electric Power Systems in Commercial Buildings (IEEE Gray Book).

IEEE Std 242-1986 (Reaff 1991), IEEE Recommended Practice for Protection and Coordination of Industrial and Commercial Power Systems (IEEE Buff Book).

¹IEEE publications are available from the Institute of Electrical and Electronics Engineers, 445 Hoes Lane, P.O. Box 1331, Piscataway, NJ 08855-1331, USA.

Chapter 2

Applications of power system analysis

2.1 Introduction

The planning, design, and operation of industrial and commercial power systems require engineering studies to evaluate existing and proposed system performance, reliability, safety, and economics. Studies, properly conceived and conducted, are a cost-effective way to prevent surprises and to optimize equipment selection. In the design stage, the studies identify and avoid potential deficiencies in the system before it goes into operation. In existing systems, the studies help locate the cause of equipment failure and misoperation, and determine corrective measures for improving system performance.

The complexity of modern industrial power systems makes studies difficult, tedious, and time-consuming to perform manually. The computational tasks associated with power systems studies have been greatly simplified by the use of digital computer programs. Sometimes, economics and study requirements dictate the use of an analog computer—a transient network analyzer (TNA)—which provides a scale model of the power system.

2.1.1 Digital computer

The digital computer offers engineers a powerful tool to perform efficient system studies. Computers permit optimal designs at minimum costs, regardless of system complexity. Advances in computer technology, like the introduction of the personal computer with its excellent graphics capabilities, have not only reduced the computing costs but also the engineering time needed to use the programs. Study work formerly done by outside consultants can now be performed in-house. User-friendly programs utilizing interactive menus, online help facilities, and a graphical user interface (GUI) guide the engineer through the task of using a digital computer program.

2.1.2 Transient network analyzer (TNA)

The TNA is a useful tool for transient overvoltage studies. The use of microcomputers to control and acquire the data from the TNA allows the incorporation of probability and statistics in switching surge analysis. One of the major advantages of the TNA is that it allows for quick reconfiguration of complex systems with immediate results, avoiding the relatively longer time associated with running digital computer programs for these systems.

2.2 Load flow analysis

Load flow studies determine the voltage, current, active, and reactive power and power factor in a power system. Load flow studies are an excellent tool for system planning. A number of operating procedures can be analyzed, including contingency conditions, such as the loss of a generator, a transmission line, a transformer, or a load. These studies will alert the user to

conditions that may cause equipment overloads or poor voltage levels. Load flow studies can be used to determine the optimum size and location of capacitors for power factor improvement. Also, they are very useful in determining system voltages under conditions of suddenly applied or disconnected loads. The results of a load flow study are also starting points for stability studies. Digital computers are used extensively in load flow studies due to the complexity of the calculations involved.

2.3 Short-circuit analysis

Short-circuit studies are done to determine the magnitude of the prospective currents flowing throughout the power system at various time intervals after a fault occurs. The magnitude of the currents flowing through the power system after a fault vary with time until they reach a steady-state condition. This behavior is due to system characteristics and dynamics. During this time, the protective system is called on to detect, interrupt, and isolate these faults. The duty imposed on this equipment is dependent upon the magnitude of the current, which is dependent on the time from fault inception. This is done for various types of faults (three-phase, phase-to-phase, double-phase-to-ground, and phase-to-ground) at different locations throughout the system. The information is used to select fuses, breakers, and switchgear ratings in addition to setting protective relays.

2.4 Stability analysis

The ability of a power system, containing two or more synchronous machines, to continue to operate after a change occurs on the system is a measure of its stability. The stability problem takes two forms: steady-state and transient. Steady-state stability may be defined as the ability of a power system to maintain synchronism between machines within the system following relatively slow load changes. Transient stability is the ability of the system to remain in synchronism under transient conditions, i.e., faults, switching operations, etc.

In an industrial power system, stability may involve the power company system and one or more in-plant generators or synchronous motors. Contingencies, such as load rejection, sudden loss of a generator or utility tie, starting of large motors or faults (and their duration), have a direct impact on system stability. Load-shedding schemes and critical fault-clearing times can be determined in order to select the proper settings for protective relays.

These types of studies are probably the single most complex ones done on a power system. A simulation will include synchronous generator models with their controls, i.e., voltage regulators, excitation systems, and governors. Motors are sometimes represented by their dynamic characteristics as are static var compensators and protective relays.

2.5 Motor-starting analysis

The starting current of most ac motors is several times normal full load current. Both synchronous and induction motors can draw five to ten times full load current when starting

them across the line. Motor-starting torque varies directly as the square of the applied voltage. If the terminal voltage drop is excessive, the motor may not have enough starting torque to accelerate up to running speed. Running motors may stall from excessive voltage drops, or undervoltage relays may operate. In addition, if the motors are started frequently, the voltage dip at the source may cause objectionable flicker in the lighting system.

By using motor-starting study techniques, these problems can be predicted before the installation of the motor. If a starting device is needed, its characteristics and ratings can be easily determined. A typical digital computer program will calculate speed, slip, electrical output torque, load current, and terminal voltage data at discrete time intervals from locked rotor to full load speed. Also, voltage at important locations throughout the system during start-up can be monitored. The study can help select the best method of starting, the proper motor design, or the required system design for minimizing the impact of motor starting on the entire system.

2.6 Harmonic analysis

A harmonic-producing load can affect other loads if significant voltage distortion is caused. The voltage distortion caused by the harmonic-producing load is a function of both the system impedance and the amount of harmonic current injected. The mere fact that a given load current is distorted does not always mean there will be undue adverse effects on other power consumers. If the system impedance is low, the voltage distortion is usually negligible in the absence of harmonic resonance. However, if harmonic resonance prevails, intolerable harmonic voltage and currents are likely to result.

Some of the primary effects of voltage distortion are the following:

- a) Control/computer system interference
- b) Heating of rotating machinery
- c) Overheating/failure of capacitors

When the harmonic currents are high and travel in a path with significant exposure to parallel communication circuits, the principal effect is telephone interference. This problem depends on the physical path of the circuit as well as the frequency and magnitude of the harmonic currents. Harmonic currents also cause additional line losses and additional stray losses in transformers.

Watt-hour meter error is often a concern. At harmonic frequencies, the meter may register high or low depending on the harmonics present and the response of the meter to these harmonics. Fortunately, the error is usually small.

Analysis is commonly done to predict distortion levels for addition of a new harmonic-producing load or capacitor bank. The general procedure is to first develop a model that can accurately simulate the harmonic response of the present system and then to add a model of the new addition. Analysis is also commonly done to evaluate alternatives for correcting problems found by measurements.

Only very small circuits can be effectively analyzed without a computer program. Typically, a computer program for harmonic analysis will provide the engineer with the capability to compute the frequency response of the power system and to display it in a number of useful graphical forms. The programs provide the capability to predict the actual distortion based on models of converters, arc furnaces, and other nonlinear loads.

2.7 Switching transients analysis

Switching transients severe enough to cause problems in industrial power systems are most often associated with inadequate or malfunctioning breakers or switches and the switching of capacitor banks and other frequently switched loads. The arc furnace system is most frequently studied because of its high frequency of switching and the related use of capacitor banks.

By properly using digital computer programs or a TNA, these problems can be detected early in the design stage. In addition to these types of switching transient problems, digital computer programs and the TNA can be used to analyze other system anomalies, such as lightning arrester operation, ferroresonance, virtual current chopping, and breaker transient recovery voltage.

2.8 Reliability analysis

When comparing various industrial power system design alternatives, acceptable system performance quality factors (including reliability) and cost are essential in selecting an optimum design. A reliability index is the probability that a device will function without failure over a specified time period. This probability is determined by equipment maintenance requirements and failure rates. Using probability and statistical analyses, the reliability of a power system can be studied in depth with digital computer programs.

Reliability is most often expressed as the frequency of interruptions and expected number of hours of interruptions during one year of system operation. Momentary and sustained system interruptions, component failures, and outage rates are used in some reliability programs to compute overall system reliability indexes at any node in the system, and to investigate sensitivity of these indexes to parameter changes. With these results, economics and reliability can be considered to select the optimum power system design.

2.9 Cable ampacity analysis

Cable ampacity studies calculate the current-carrying capacity (ampacity) of power cables in underground or above ground installations. This ampacity is determined by the maximum allowable conductor temperature. In turn, this temperature is dependent on the losses in the cable, both I^2R and dielectric, and thermal coupling between heat-producing components and ambient temperature.

The ampacity calculations are extremely complex. This is due to many considerations, some examples of which are heat transfer through the cable insulation and sheath, and, in the case of underground installations, heat transfer to duct or soil as well as from duct bank to soil. Other considerations include the effects of losses caused by proximity and skin effects. In addition, depending on the installation, the cable-shielding system may introduce additional losses. The analysis involves the application of thermal equivalents of Ohm's and Kirchoff's laws to a thermal circuit.

2.10 Ground mat analysis

Under ground-fault conditions, the flow of current will result in voltage gradients within and around the substation, not only between structures and nearby earth, but also along the ground surface. In a properly designed system, this gradient should not exceed the limits that can be tolerated by the human body.

The purpose of a ground mat study is to provide for the safety and well-being of anyone that can be exposed to the potential differences that can exist in a station during a severe fault. The general requirements for industrial power system grounding are similar to those of utility systems under similar service conditions. The differences arise from the specific requirements of the manufacturing or process operations.

Some of the factors that are considered in a ground-mat study are the following:

- a) Fault-current magnitude and duration
- b) Geometry of the grounding system
- c) Soil resistivity
- d) Probability of contact
- e) Human factors such as
 - 1) Body resistance
 - 2) Standard assumptions on physical conditions of the individual

2.11 Protective device coordination analysis

The objective of a protection scheme in a power system is to minimize hazards to personnel and equipment while allowing the least disruption of power service. Coordination studies are required to select or verify the clearing characteristics of devices such as fuses, circuit breakers, and relays used in the protection scheme. These studies are also needed to determine the protective device settings that will provide selective fault isolation. In a properly coordinated system, a fault results in interruption of only the minimum amount of equipment necessary to isolate the faulted portion of the system. The power supply to loads in the remainder of the system is maintained. The goal is to achieve an optimum balance between equipment protection and selective fault isolation that is consistent with the operating requirements of the overall power system.

Short-circuit calculations are a prerequisite for a coordination study. Short-circuit results establish minimum and maximum current levels at which coordination must be achieved and which aid in setting or selecting the devices for adequate protection. Traditionally, the coordination study has been performed graphically by manually plotting time-current operating characteristics of fuses, circuit breaker trip devices, and relays, along with conductor and transformer damage curves—all in series from the fault location to the source. Log-log scales are used to plot time versus current magnitudes. These “coordination curves” show graphically the quality of protection and coordination possible with the equipment available. They also permit the verification/confirmation of protective device characteristics, settings, and ratings to provide a properly coordinated and protected system.

With the advent of the personal computer, the light-table approach to protective device coordination is being replaced by computer programs. The programs provide a graphical representation of the device coordination as it is developed. In the future, computer programs are expected to use expert systems based on practical coordination algorithms to further assist the protection engineer.

2.12 DC auxiliary power system analysis

The need for direct current (dc) power system analysis of emergency standby power supplies has steadily increased during the past several years in data processing facilities, long distance telephone companies, and generating stations.

DC emergency power is used for circuit breaker control, protective relaying, inverters, instrumentation, emergency lighting, communications, annunciators, fault recorders, and auxiliary motors. The introduction of computer techniques to dc power systems analysis has allowed a more rapid and rigorous analysis of these systems compared to earlier manual techniques.

Chapter 3

Analytical procedures

3.1 Introduction

With the development of the digital computer and advanced computer programming techniques, power system problems of the most complex types can be rigorously analyzed. Previously, solutions were usually only approximate. Limitations and errors were introduced by the many simplifying assumptions necessary to permit classical longhand calculating procedures. For progress to be realized in using the computer for power system analysis, it has been necessary for the creators of power system analysis computer programs to thoroughly understand the application of basic analytical solution methods that apply. It is also important for those concerned with assembling and preparing data for input to a power system analysis computer program and those interpreting and applying results generated by such a program to understand the application of analytical solution methods.

This chapter identifies and documents the basic analytical solution methods that are valid for determining the voltage and current relationships that exist during various power system network events and operating conditions. These basic analytical solution methods are demonstrated in cases where they are not self-evident. Finally, critical restraints that must be respected to avoid serious error in applying analytical solution methods will be discussed.

Whether a power system analysis problem is to be solved directly or by a computer program, proper application of sound analytical solution methods is essential for three reasons. First, accuracy of the solution to each individual problem being considered will be directly affected. Second, and perhaps the most important because of the significant expense involved, accuracy of the solution determines the validity and effectiveness of any remedial measures suggested. Finally, extension of erroneous results to related problems or to what appears to be a trivial modification of the original problem, possibly in combination with other misapplied or misunderstood techniques, can lead to a compounding of initial error and a progression of incorrect conclusions.

The most common causes of errors in circuit analysis work are the following:

- a) Failure to use a valid analytical procedure because the analyst is unaware of its existence or applicability
- b) Careless or improper use of “cookbook” methods that have neither a factual basis, nor support in the technical literature, nor a valid place in the electrical engineering discipline
- c) Improper use of a valid solution method due to application beyond limiting boundary restraints or in combination with an inaccurate simplifying assumption

Many situations occur in industrial and commercial power systems that illustrate some or all of these common causes of error, as well as the resulting evils. Any problem investigated as a

part of the general types of power system analysis studies covered in other sections of this recommended practice and described as follows would qualify.

- Short-circuit studies
- Load analysis studies
- Load flow studies
- Stability studies
- Motor-starting studies
- Harmonic studies
- Reliability studies
- Ground mat studies
- Switching transient studies

3.2 Fundamentals

The following list identifies the more important analytical solution methods that are either available as, or are the basis for, valid techniques in solving power system network circuit problems:

- a) Linearity
- b) Superposition
- c) Thevenin and Norton equivalent circuits
- d) Sinusoidal forcing function
- e) Phasor representation
- f) Fourier representation
- g) Laplace transform
- h) Single-phase equivalent circuit
- i) Symmetrical component analysis
- j) Per unit method

Rigorous treatment of these analytical techniques is available in several circuit analysis texts (Beeman [B1]¹, Close [B3], Hayt and Kemmerly [B7], Stevenson, Jr. [B14], Wagner and Evans [B15], Weedy [B16]) and is beyond the scope of this discussion. In the following sub-clauses of this chapter, however, a brief qualitative explanation of each principle is presented, along with a review of major benefits and restraints associated with the use of each principle.

3.2.1 Linearity

Probably the simplest concept of all, linearity is also one of the most important because of its influence on the other principles. Linearity is best understood by examination of Figure 3-1.

The simplified network represented by the single-impedance element Z in Figure 3-1(a) is linear for the chosen excitation and response functions, if a plot of response magnitude

¹The numbers in brackets correspond to those of the bibliography in 3.3.

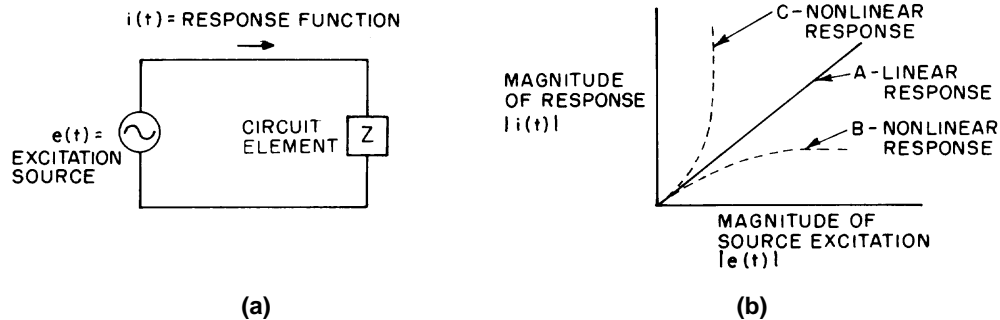

Figure 3-1—Linearity

(current) versus source excitation magnitude (voltage) is a straight line. This is the situation shown for case A in Figure 3-1(b). When linearity exists, the plot applies either to the steady-state value of the excitation and response functions or to the instantaneous value of the functions at a specific time.

When linear dc circuits are involved, the current doubles if the voltage is doubled. The same holds for linear ac circuits if the frequency of the driving voltage is held constant. In a similar manner, it is possible to predict the response of a *constant* impedance circuit (that is, constant R , L , and C elements) to any magnitude of dc source excitation or *fixed frequency* sinusoidal excitation based on the known response at any other level of excitation. For the chosen excitation function of voltage and the chosen response function of current, both dotted curves B and C are examples of the response characteristic of a nonlinear element.

With the circuit element represented by any of the response curves shown in Figure 3-1 (including the linear element depicted by curve A), the circuit will, in general, become nonlinear for a different response function—for example, power. If, for example, the element was a constant resistance (which would have a linear voltage-current relationship), the power dissipated would increase by a factor of 4 if voltage were doubled ($P = I^2R$).

An important limitation of linearity, therefore, is that it applies only to responses that are linear for the circuit conditions described (that is, a constant impedance circuit will yield a current that is linear with voltage). This restraint must be recognized in addition to the previously mentioned limitations of constant source excitation frequency for ac circuits and constant circuit element impedances for ac or dc circuits. Excitation sources, if not independent, must be linearly dependent. This restraint forces a source to behave just as would a linear response (which, by definition, is also linearly dependent).

3.2.2 Superposition

This very powerful principle is a direct consequence of linearity and can be stated as follows:

In any linear network containing several dc or fixed frequency ac excitation sources (voltages), the total response (current) can be calculated by algebraically adding all the

individual responses caused by each independent source acting alone, i.e., all other sources inactivated (voltage sources shorted by their internal impedances, current sources opened).

An example that illustrates this principle is shown in Figure 3-2. The equation written is for the sum of the currents from each individual source V_1 and V_2 . Although Figure 3-2 also illustrates a way this principle might actually be used, more often its main application is in support of other calculating methods. The only restraint associated with superposition is that the network should be linear. All limitations associated with linearity apply.

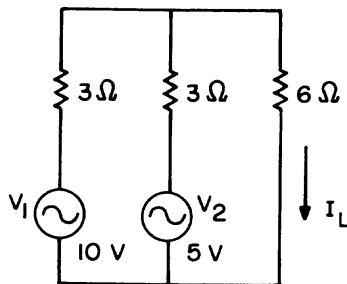

$$\begin{aligned}
 I_L &= I_{V_1} + I_{V_2} \\
 &= \frac{10}{\left(3 + \frac{6 \cdot 3}{6+3}\right)} \left(\frac{6 \cdot 3}{6+3}\right) \cdot \frac{1}{6} + \frac{5}{\left(3 + \frac{6 \cdot 3}{6+3}\right)} \left(\frac{6 \cdot 3}{6+3}\right) \cdot \frac{1}{6} \\
 &= \frac{10}{5} \cdot 2 \cdot \frac{1}{6} + \frac{5}{5} \cdot 2 \cdot \frac{1}{6} \\
 &= \frac{2 \cdot 2}{6} + \frac{2}{6} = \frac{2}{3} + \frac{1}{3} = 1 \text{ A}
 \end{aligned}$$

Figure 3-2—Superposition

The nonapplicability of superposition is why all but the very simplest nonlinear circuits are almost impossible to analyze using hand calculations. Although most real circuit elements are nonlinear to some extent, they can often be accurately represented by a linear approximation. Solutions to network problems involving such elements can be readily obtained.

Problems involving complex networks having substantially nonlinear elements can practically be solved only through the use of certain simplification procedures, or through the adjustment of calculated results to correct for nonlinearity. But both of these approaches can potentially lead to significant inaccuracy. Tiresome iterative calculations performed in an instant by the digital computer make more accurate solutions possible when the nonlinear circuit elements can be described mathematically.

3.2.3 Thevenin and Norton equivalent circuits

The Thevenin equivalent circuit is a powerful analysis tool based on the fact that any active linear network, however complex, can be represented by a single voltage source, V_{OC} , equal to the open-circuit voltage across any two terminals of interest, in series with the equivalent impedance, Z_{EQ} , of the network viewed from the same two terminals with all sources in the network inactivated (voltage sources shorted by their internal impedances, current sources opened). Validity of this representation requires only that the network be linear. Existence of linearity is a necessary restraint. Application of the Thevenin equivalent circuit can be appreciated by referring to the simple circuit of Figure 3-2 and developing the Thevenin equivalent for the network with the switch in the open position as illustrated in Figure 3-3.

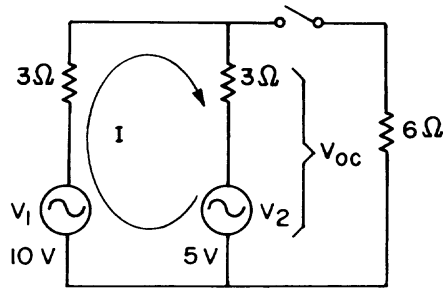

(a)

$$\begin{aligned} V_{oc} &= I \cdot 3 + 5 \\ &= \frac{10-5}{6} \cdot 3 + 5 \\ &= \frac{5}{2} + 5 = \frac{15}{2} \\ &= 7.5 \text{ V} \end{aligned}$$

$$Z_{EQ} = \frac{3 \cdot 3}{3+3} = \frac{9}{6} = \frac{3}{2} \Omega$$

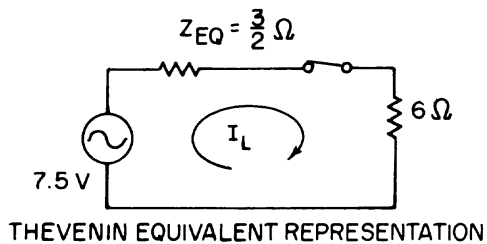

(b)

$$\begin{aligned} I_L &= 7.5 \cdot \frac{1}{6 + \frac{3}{2}} \\ &= \frac{15}{2} \cdot \frac{2}{12+3} \\ &= 15 \cdot \frac{1}{15} = 1 \text{ A} \end{aligned}$$

Figure 3-3—Thevenin equivalent

After connecting the 6Ω load to the Thevenin equivalent network by closing the switch, the solution for I_L is the same as before, 1 A. Use of the simple Thevenin equivalent shown for the entire left side of the network makes it easy to examine circuit response as the load impedance value is varied.

The Thevenin equivalent circuit solution method is equally valid for complex impedance circuits. It is the type of representation shown in Figure 3-3 that is the basis for making per unit short-circuit calculations, although the actual values for the source voltage and branch impedances would be substantially different from those used in this case. (The circuit property of linearity would, incidentally, allow them to be scaled up or down.) The network shown in Figure 3-3(a), with the 6Ω resistance shorted and the other resistances visualized as reactances, might well serve as an oversimplified representation of a power system about to experience a bolted fault with the closing of the switch.

The V_1 branch of the circuit would correspond to the utility supply while the V_2 branch might represent a large motor running unloaded, immediately adjacent to the fault bus, and highly idealized so as to have no rotor flux leakage. For such a model, the 5 V source corresponds to the pre-fault, air-gap voltage behind a stator leakage (subtransient) reactance of 3Ω [B4]. In a more realistic situation where rotor leakage is evident, a model that accurately describes the V_2 branch in detail before and after switch closing is much more difficult to develop, because the air-gap voltage decreases (exponentially) with time and varies (linearly) with the steady-

state rms magnitude of the motor stator current following application of the fault. The problem of accounting for motor internal behavior is avoided altogether by use of a Thevenin equivalent. This permits the V_2 branch to be represented by the apparent motor impedance effective at the time following switch closure. In shunt with the equivalent impedance for the remainder of the network, the Thevenin equivalent impedance, Z_{EQ} , for the motor (at any point in time of interest) is simply connected in series with the pre-fault open-circuit voltage, V_{OC} , to obtain the corresponding current response to switch closing.

The current response obtained in each branch of a network using a Thevenin equivalent circuit solution represents the *change* of current in that branch. The actual current that flows is the vector sum of currents before and after the particular switching event being considered. See Figure 3-4.

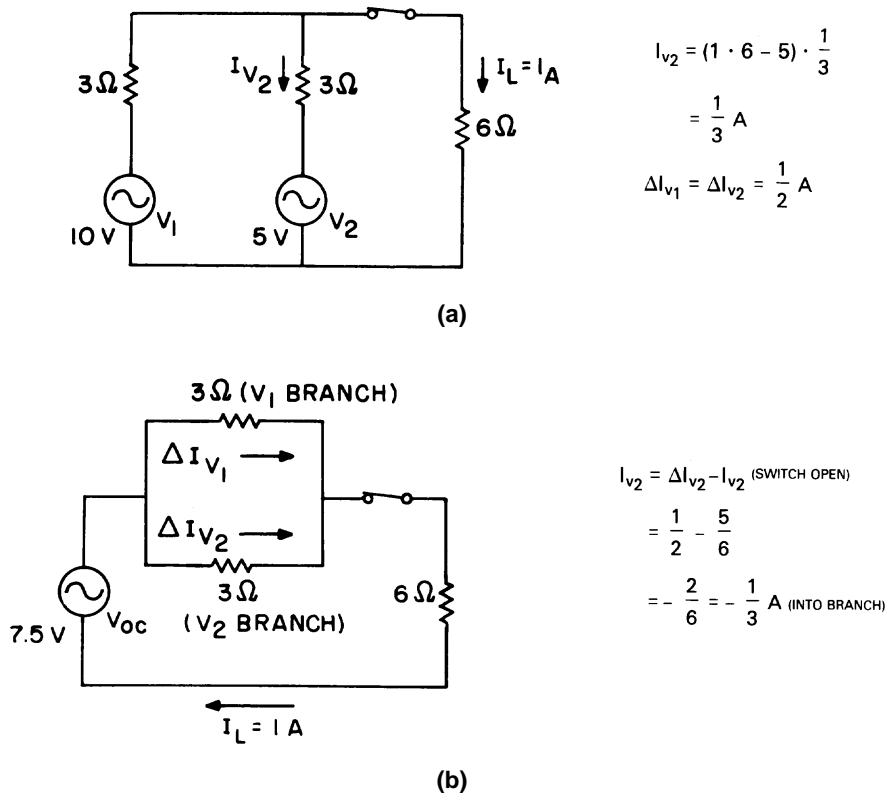

Figure 3-4—Current flow of a Thevenin equivalent representation

In Figure 3-4(a), the current flowing in the V_2 branch circuit is shown to be $1/3$ A. A more detailed representation of the Thevenin equivalent circuit previously examined in Figure 3-3 is shown in Figure 3-4(b). Here, the solution for the same current I_{V_2} is determined by subtracting the current flowing in the V_2 branch prior to closing the switch [$5/6$ A from inspection of the circuit in Figure 3-3(a)] from the current $I_{V_2} = 1/2$ A, calculated to be flowing in the Thevenin equivalent for this V_2 branch.

In the branch of the circuit defined by the switch itself, the *change of current* due to closing is normally the response of interest. This means the solution to the Thevenin equivalent is sufficient. The resultant current in the other branches, however, cannot be determined by the solution to the Thevenin equivalent network alone.

In the case where the V_2 branch represents a motor switched onto a bolted fault, the motor contribution is the locked-rotor current minus the pre-fault current as illustrated in Figure 3-5 and not just the locked-rotor current as it is so often carelessly described.

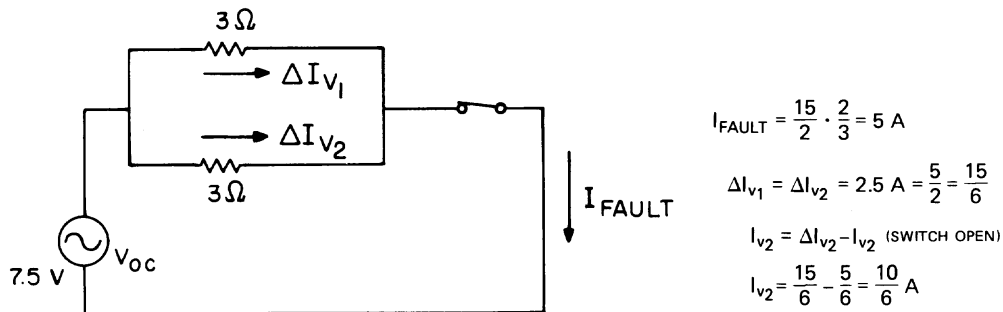

Figure 3-5—Fault flow

As a rule, this effect is never as significant as the example suggests, even when the motor is loaded prior to the fault; the load current is much smaller than the locked-rotor current and almost 90° out of phase with it.

A Norton equivalent circuit, which can be developed directly from the Thevenin equivalent circuit, consists of a current source of magnitude, V_{OC}/Z_{EQ} , to account for the voltage sources in *each* separate branch of the network in *parallel* with the same equivalent impedance for that branch, Z_{EQ} . This representation of circuits can be useful in power system analysis work if some of the sources are true current sources, as is often the case when performing harmonic studies.

3.2.4 Sinusoidal forcing function

It is a most fortunate truth in nature that the excitation sources (driving voltage) for electrical networks, in general, have a sinusoidal character and can be represented by a sine wave plot of the type illustrated in Figure 3-6.

There are two important consequences of this circumstance. First, although the response (current) for a complex R, L, C network represents the solution to at least one second-order differential equation, the result will also be a sinusoid of the same frequency as the excitation and different only in magnitude and phase angle. The relative character of the current with respect to the voltage for simple R, L , and C circuits is also shown in Figure 3-6.

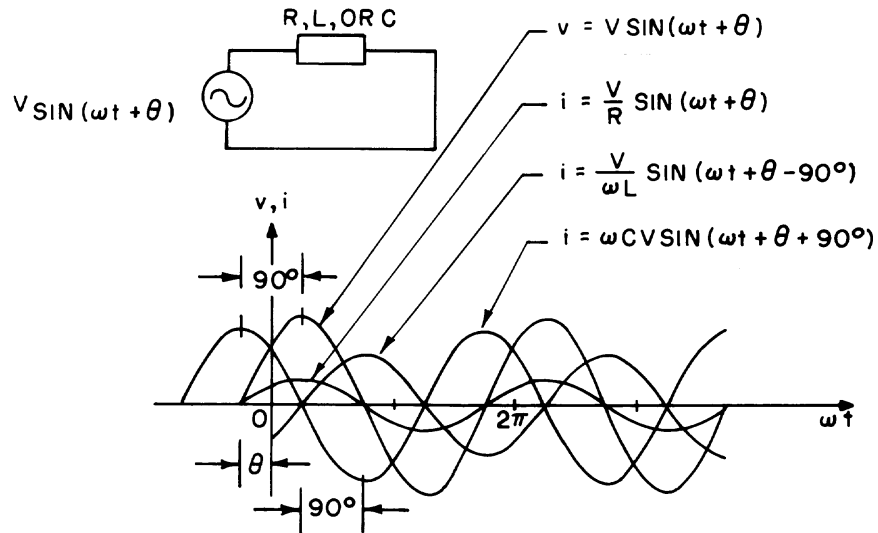

Figure 3-6—Sinusoidal forcing function

The second important concept is that when the sine wavelike shape of current is forced to flow in a general impedance network of R , L , and C elements, the voltage drop across each element will always exhibit a sinusoidal shape of the same frequency as the source. The sinusoidal character of all the circuit responses makes the application of the superposition technique to a network with multiple sources surprisingly manageable. The necessary manipulation of the sinusoidal terms is easily accomplished using the laws of vector algebra, which evolve from the next technique to be reviewed.

The only restraint associated with the use of the sinusoidal forcing function concept is that the circuit must be comprised of linear elements, that is, R , L , and C are constant as current or voltage varies.

3.2.5 Phasor representation

Phasor representation allows any sinusoidal forcing function to be represented as a phasor in a complex coordinate system as shown in Figure 3-7.

As indicated, the expression for the phasor representation of a sinusoid can assume any of the following shorthand forms:

Exponential: $E e^{j\theta}$

Rectangular: $E \cos \theta + jE \sin \theta$

Polar: $E \angle \theta$

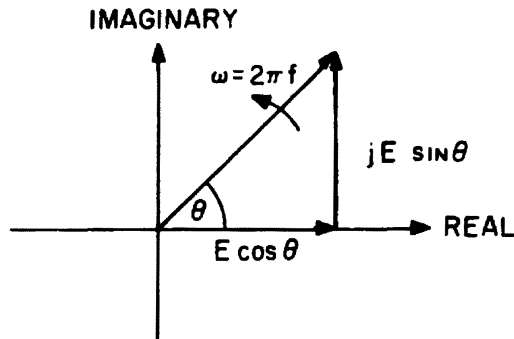

R = resistance
X_L = inductive reactance
X_C = capacitive reactance
Z = impedance

$$Ee^{j\theta} = E \cos \theta + jE \sin \theta = |E| \angle \theta$$

$$I = \frac{E}{Z} = \frac{|E|}{|Z|} \frac{e^{j\theta}}{e^{j\Phi}} = \frac{|E|}{|Z|} e^{j(\theta - \Phi)}$$

$$Z = R + j \omega L + -j \frac{1}{\omega C} = R + jX$$

$$X = X_L - X_C$$

$$X_L = \omega L$$

$$X_C = \frac{1}{\omega C}$$

$$|Z| = \sqrt{R^2 + X^2}$$

$$\Phi = \tan^{-1} \frac{X}{R}$$

Figure 3-7—Phasor representation

For most calculations, it is more convenient to work in the frequency domain where any angular velocity associated with the phasor is ignored, which is equivalent to assuming the coordinate system rotates at a constant angular velocity of ω . The impedances of the network can likewise be represented as phasors using the vectorial relationships shown. As illustrated, the circuit responses (current) can be obtained through the simple vector algebraic manipulation of the quantities involved. The need for solving complex differential equations to determine the circuit responses is completely eliminated. The restraints that apply are as follows:

- Sources must all be sinusoidal
- Frequency must remain constant
- Circuit R , L , and C elements must remain constant (that is, linearity must exist)

3.2.6 Fourier representation

This powerful tool allows any nonsinusoidal periodic forcing function, of the type plotted in Figure 3-8, to be represented as the sum of a dc component and a series (infinitely long, if necessary) of ac sinusoidal forcing functions. The ac components have frequencies that are integral multiples of the periodic function fundamental frequency. The general mathematical form of the *Fourier series* is also shown in Figure 3-8.

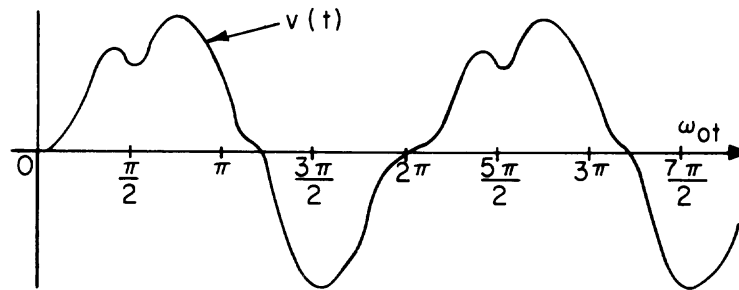

$$V(t) = V_0 + V_1 \cos \omega_0 t + V_2 \cos 2 \omega_0 t + \dots \\ + V_1' \sin \omega_0 t + V_2' \sin 2 \omega_0 t + \dots$$

Figure 3-8—Fourier representation

The importance of the Fourier representation is immediately apparent. The response to the original driving function can be determined by first solving for the response to each Fourier series component forcing function and summing all the individual solutions to find the total superposition. Since each component response solution is readily obtained, the most difficult part of the problem becomes the determination of the component forcing function. The individual harmonic voltages can be obtained, occasionally in combination with numerical integration approximating techniques through several well-established mathematical procedures. Detailed discussion of their use is better reserved for the many excellent texts (Close [B3], Hayt and Kemmerly [B7]) that treat the subject.

There are several abstract mathematical conditions that must be satisfied to use a Fourier representation. The only restraints of practical interest to the power systems analyst are that the original driving function must be periodic (repeating) and the network must remain linear.

3.2.7 Laplace transform

In the solution of circuit transients by classical methods, the models of circuit elements are represented with sets of differential equations. In addition, for a specific problem, a set of initial conditions must be known in order to solve the differential equations for the unknown quantity. An alternative technique for solving a transient problem is by the use of the Laplace transform. The proper use of this technique eliminates the need for the solution of the differential equations and simplifies all mathematical manipulations to elementary algebra.

It is helpful to keep in mind that the concept of mathematical transformations to simplify the solution to a problem is not new. For example, the mathematical operations of multiplication and division are transformed into the simpler operations of addition and subtraction by means of the logarithm transform. Once the addition/subtraction is performed, the solution to the problem is obtained by using the inverse transform, or antilog operation. The transformation is designed to create a new “domain” where the mathematical manipulations are easier to carry out. Once the unknown is found in the new domain, it can be inverse-transformed back to the original domain.

In circuit analysis, the Laplace transform is used to transform the set of differential equations from the time domain (t) to a set of algebraic equations in the new domain called the complex frequency domain or, alternatively, the s -domain. The Laplace transform of a function is given by the expression

$$L\{f(t)\} = \int_0^{\infty} f(t)e^{-st} dt \quad (3-1)$$

where the symbol $L\{f(t)\}$ is read as “the Laplace transform of $f(t)$.”

The Laplace transform is also denoted by the notation $F(s)$, that is,

$$F(s) = L\{f(t)\} \quad (3-2)$$

This notation emphasizes that once the above integral has been evaluated, the resulting expression is a function of s . Since the exponent of the e in Equation (3-1) must be dimensionless, s must have the units of reciprocal time, hence the use of the alternate terms “frequency domain” and “ s -domain” to describe the realm of the transformed function.

It can be shown that the “transformation” (or, more briefly, “transform”) described by Equation (3-1) has special mathematical properties. Given an original expression involving both an unknown function (i.e., current, voltage, etc.), and operations on that function (i.e., derivatives, integrals, etc.), the s -domain expression that results when each term is transformed according to Equation (3-1) can be manipulated by ordinary algebraic procedures to yield a solution for the unknown function. The solution for the unknown function in the s -domain can then be transformed back to the time domain to produce the desired result. These mathematical methods can be used to greatly simplify the solution of complex differential equations.

The solution of a system problem involving a linear expression can then be determined in four simple steps, as follows:

- a) Formulate the differential time domain equations for the particular expression, which may contain terms like

$$Ri(t), C \frac{dv}{dt}, \int_0^t i(t) dt, \text{ etc.} \quad (3-3)$$

- b) Find the Laplace transform of the terms in the differential equation, including any initial conditions, according to the definition of the Laplace transform or using Laplace transform tables and equivalent circuit tables such as that shown in Table 3-1 and Table 3-2, respectively.
- c) Solve the transform for the unknown variable. The form of the s function should be manipulated into a form similar to those available in tables of Laplace transform pairs.
- d) From a table, find the inverse Laplace transform of the unknown.

Table 3-1—Laplace transform pairs

$f(t)$ ($t > 0^-$)	$F(s)$
$\delta(t)$	1
$u(t)$	$\frac{1}{s}$
t	$\frac{1}{s^2}$
e^{-at}	$\frac{1}{s+a}$
$\sin \omega t$	$\frac{\omega}{s^2 + \omega^2}$
$\cos \omega t$	$\frac{s}{s^2 + \omega^2}$
te^{-at}	$\frac{1}{(s+a)^2}$
$e^{-at} \sin \omega t$	$\frac{\omega}{(s+a)^2 + \omega^2}$
$e^{-at} \cos \omega t$	$\frac{s+a}{(s+a)^2 + \omega^2}$

where

$\delta(t)$ is called the unit impulse function defined as

$$\delta(t) = 0 \text{ for } t \neq 0 \text{ and } \int_{-\infty}^{\infty} \delta(t) dt = 1$$

$u(t)$ is called the unit step function defined as

$$u(t) = \begin{cases} 1 & t \geq 0 \\ 0 & t < 0 \end{cases}$$

An alternate approach is to interchange steps a) and b) above. In this case, the network is first transformed into the s -domain so that all the advantages of impedance and admittance operations and the use of network solution techniques such as mesh/nodal analysis and Thevenin/Norton equivalent circuits become available.

Applying this transformation to all elements in the system under study, the result will be a network consisting of s -domain equivalent elements. Then, usual circuit analysis will provide the quantities of interest in the s -domain. Finally, from a table of inverse Laplace transforms, the quantity of interest in the time domain can be obtained. In subsequent paragraphs, we will discuss the Laplace transform and its application to the solution of transient problems.

3.2.7.1 Transient analysis by Laplace transforms

The transient analysis of a circuit using Laplace transforms is a straightforward application of elementary algebra. Both the excitation sources and the impedance elements of the system

Table 3-2—s-domain equivalent circuits

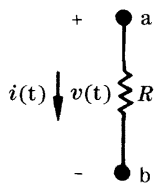
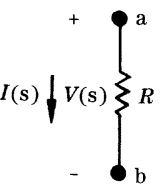
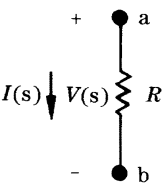
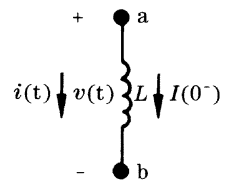
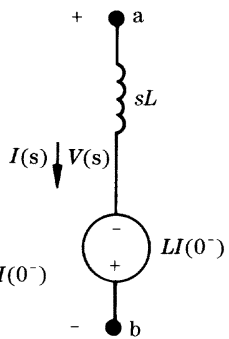
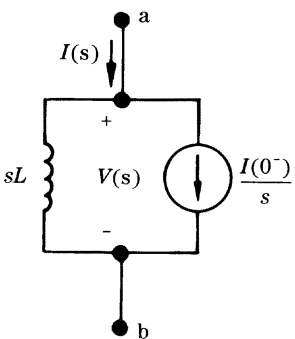
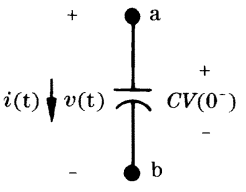
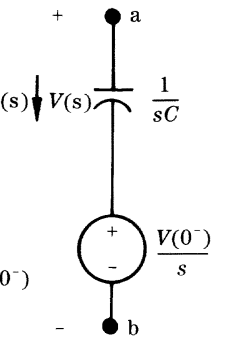
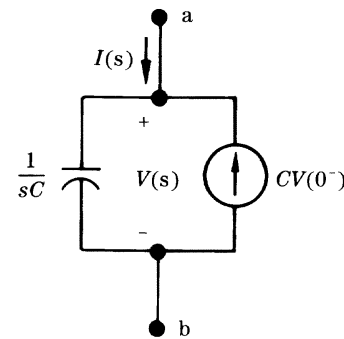
Time Domain	Frequency Domain	
 <p style="text-align: center;">$v(t) = Ri(t)$</p>	 <p style="text-align: center;">$V(s) = RI(s)$</p>	 <p style="text-align: center;">$I(s) = \frac{V(s)}{R}$</p>
 <p style="text-align: center;">$v(t) = L \frac{di(t)}{dt}$</p> <p style="text-align: center;">$i(t) = \frac{1}{L} \int_{0^-}^t v(t) dx + I(0^-)$</p>	 <p style="text-align: center;">$V(s) = sLI(s) - LI(0^-)$</p>	 <p style="text-align: center;">$I(s) = \frac{V(s)}{sL} + \frac{I(0^-)}{s}$</p>
 <p style="text-align: center;">$i(t) = C \frac{dv(t)}{dt}$</p> <p style="text-align: center;">$v(t) = \frac{1}{C} \int_{0^-}^t i(t) dx + V(0^-)$</p>	 <p style="text-align: center;">$V(s) = \frac{I(s)}{sC} + \frac{V(0^-)}{s}$</p>	 <p style="text-align: center;">$I(s) = sCV(s) - CV(0^-)$</p>

under study must be replaced with their s -domain equivalent circuits. Table 3-1 contains Laplace transform pairs for commonly used excitation sources. The Laplace transform of the driving voltages and/or currents in the studied circuit must be determined for use in the s -domain equivalent circuit. Using Table 3-2, one of two possible s -domain equivalent circuits must be chosen for each impedance element in the circuit. Once the s -domain network has been developed, the circuit equations can be solved algebraically.

The following examples will illustrate the procedure. They are simple and could very well be solved with less sophistication.

3.2.7.1.1 RL and RC transients

The study of RL transients will begin with a series RL network with a constant (step function) voltage source $V(t)$ applied to the circuit through the closing of a switch. The network is illustrated in Figure 3-9.

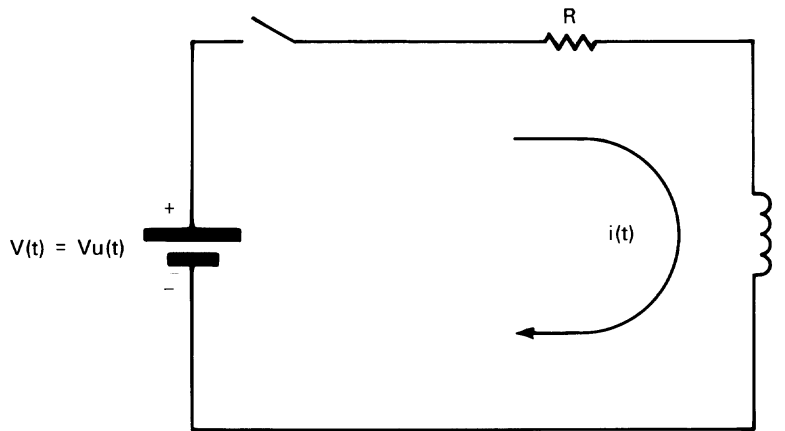

Figure 3-9— RL network

According to Kirchoff's voltage law, at $t = 0^+$ the equation describing the circuit is

$$Vu(t) = Ri(t) + L \frac{di}{dt} \quad (3-4)$$

Converting the terms of the above equation into the s -domain, according to either Table 3-1 or Table 3-2, yields

$$\frac{V}{s} = RI(s) + sLI(s) - LI(0^-) \quad (3-5)$$

Since there could be no current flowing prior to the closing of the switch, the last term on the right can be ignored (initial conditions equal to zero). Solving for the current according to 3.2.7 step c), the result is

$$I(s) = \frac{V}{L} \left[\frac{1}{s \left(s + \frac{R}{L} \right)} \right] = \frac{V}{R} \left[\frac{1}{s} - \frac{1}{s + \frac{R}{L}} \right] \quad (3-6)$$

The transient response is readily obtained from Table 3-1 as

$$i(t) = \frac{V}{R} [1 - e^{-tR/L}] \quad (3-7)$$

The current $i(t)$ is shown graphically in Figure 3-10.

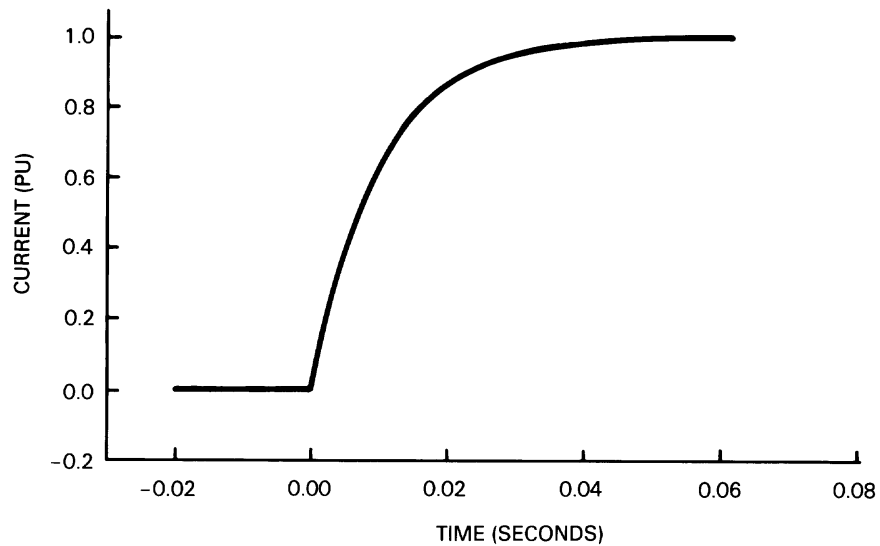

Figure 3-10—Current response (Equation [3-7])

The next circuit to be examined is the RC network depicted in Figure 3-11, already drawn in the symbols of the Laplace transform. The equation describing the circuit is

$$\frac{V}{s} = RI(s) \times \frac{I(s)}{sC} - \frac{V_c(0^-)}{s} \quad (3-8)$$

Assuming there is no initial charge in the capacitor [$V_c(0^-) = 0$] and solving for the current, yields

$$I(s) = \frac{V}{R} \left[\frac{1}{s + 1/RC} \right] \quad (3-9)$$

Again, using the appropriate inverse Laplace transform from Table 3-1, the transient response in the time domain is

$$i(t) = \frac{V}{R} e^{-tR/C} \quad (3-10)$$

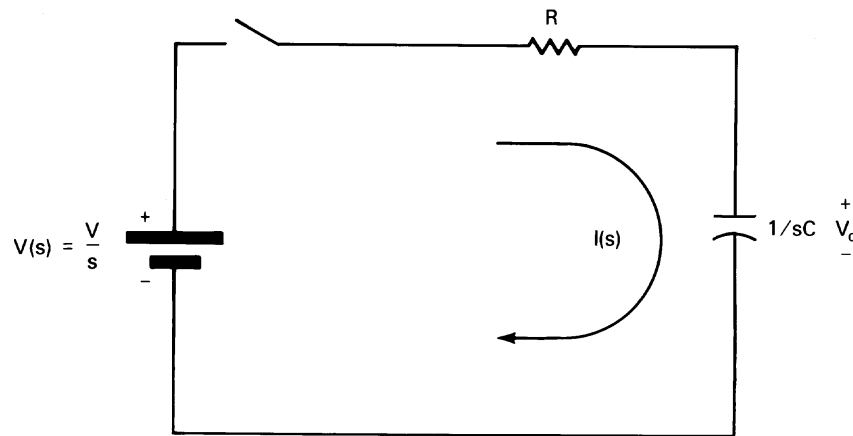

Figure 3-11—RC network

The current response of the RC circuit is shown graphically in Figure 3-12.

If the quantity of interest was the voltage across the capacitor, then from Ohm's law we would have

$$V_{c(s)} = I(s)Z(s) \quad (3-11)$$

Where $I(s)$ is defined by Equation (3-9) and $Z(s)$ is the capacitor impedance, namely

$$Z(s) = \frac{-1}{sC} \quad (3-12)$$

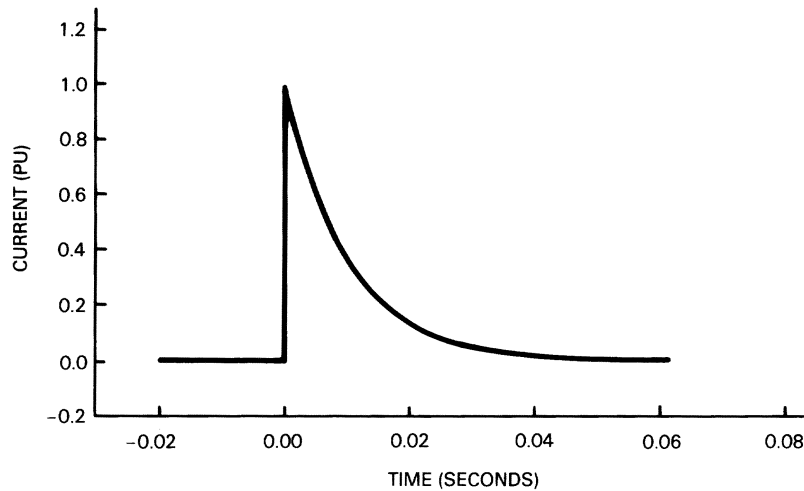

Figure 3-12—Current response (Equation [3-10])

Since, in a series circuit, the current is common to all elements, we can substitute Equation (3-12) into Equation (3-11). After solving for $I(s)$, we substitute the result into Equation (3-9). Rearranging the terms, we obtain

$$V_c(s) = \frac{V}{RC} \left[\frac{1}{s(s + 1/RC)} \right] = V \left[\frac{1}{s} - \frac{1}{s + 1/RC} \right] \quad (3-13)$$

From Table 3-1, the voltage across the capacitor in the time domain is

$$V_c(t) = V(1 - e^{-t/RC}) \quad (3-14)$$

The capacitor voltage described by Equation (3-14) is shown graphically in Figure 3-13.

3.2.7.1.2 Circuits involving all three circuit elements

In cases involving more advanced circuits, the next step is the combination of all three components, R , L , and C , in a common network. This approach is considered in Chapter 11 of this book, where additional circuits with higher degrees of difficulty are investigated using the same basics presented here.

3.2.8 Single-phase equivalent circuit

The single-phase equivalent circuit is a powerful tool for simplifying the analysis of balanced three-phase circuits, yet its restraints are probably most often disregarded. Its application is best understood by examining a three-phase diagram of a simple system and its single-phase equivalent, as shown in Figure 3-14. Also illustrated is the popular single-line diagram representation commonly used to describe the same three-phase system on engineering drawings.

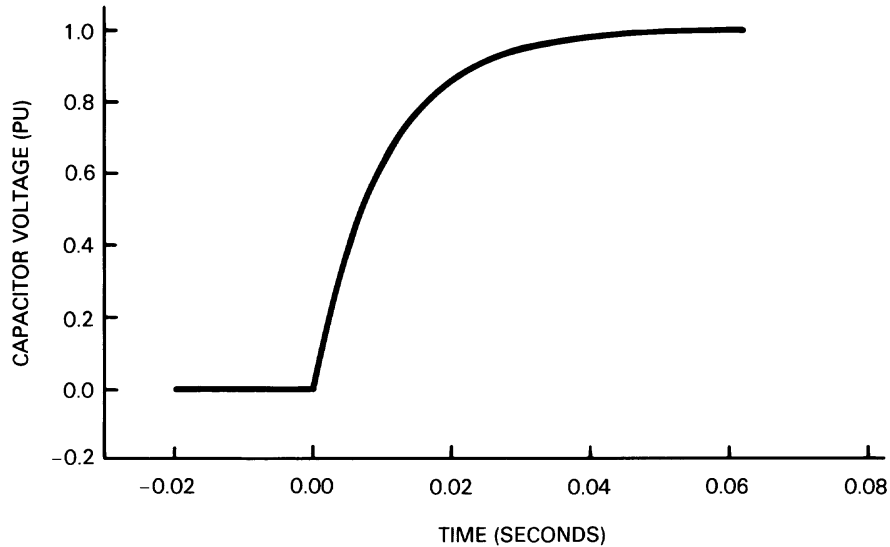

Figure 3-13—Voltage response

If a three-phase system has a perfectly balanced symmetrical source excitation (voltage) and load, as well as equal series and shunt system and line impedances connected to all three phases [see Figure 3-14(a)], imagine a conductor (shown as a dotted line) carrying no current connected between the effective neutrals of the load and the source. Under these conditions, the system can be accurately described by either Figure 3-14(b) or Figure 3-14(c).

The single-phase equivalent circuit is particularly useful since the solution to the classical loop equations is much easier to obtain than for the more complicated three-phase network. To determine the complete solution, it is only necessary to realize that the other two phases will have responses that are shifted by 120° and 240° but are otherwise identical to the reference phase.

Anything that upsets the balance of the network renders the model invalid. A subtle way this might occur is illustrated in Figure 3-15.

If the switching devices operate independently in each of the three poles, and for some reason the device in phase A becomes opened, the balance or symmetry of the circuit is destroyed. Neither the single-phase equivalent nor the single-line diagram representation is valid. Even though the single-phase and the single-line diagram representations would imply that the load has been disconnected, it continues to be energized by single-phase power. This can cause serious damage to motors and result in unacceptable operation of certain load apparatus.

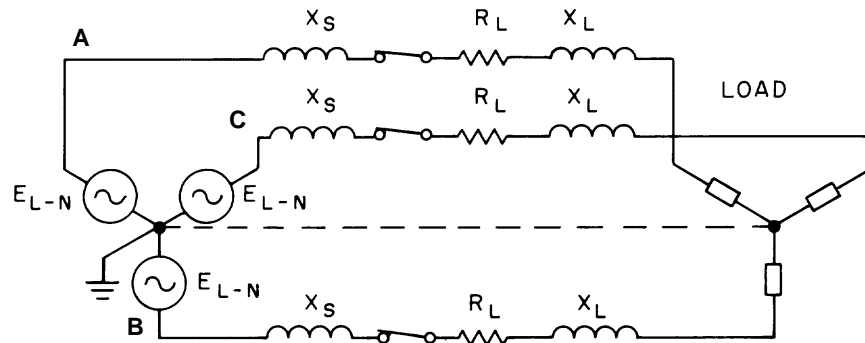

(a) Three-phase diagram

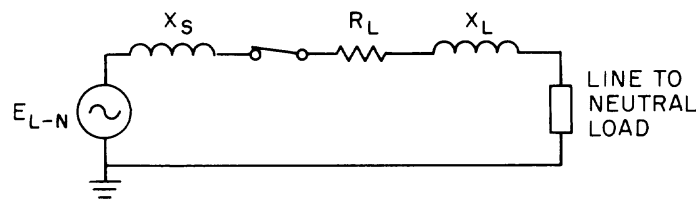

(b) Single-phase equivalent

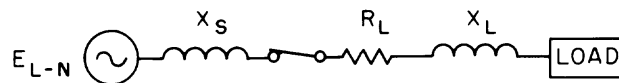

(c) Single-line impedance diagram

Figure 3-14—A balanced three-phase system with load connected prior to fault

More importantly, if only one switching device operates in response to a fault condition in the same phase, as depicted at location X, the system sources would continue to supply fault current from the other unopened phases through the impedance of the load. The throttling effect of the normally substantial load impedance, possibly in combination with additional arc impedance, can reduce the level of the current to a point where detection may not occur in phases B and C. Needless to say, substantial damage can result before the fault finally burns enough to involve the other phases directly and accomplish complete interruption. Meanwhile, both of the single-line representations fail to recognize the problem, and in fact, suggest that the condition has been safely disconnected. Therefore, the restraints of this calculating aid are as follows:

- a) Symmetry of the electrical system, including all switching devices and applied load.
- b) Any of the other previously described restraints that apply to the analytical technique being used in combination with the single-phase equivalent.

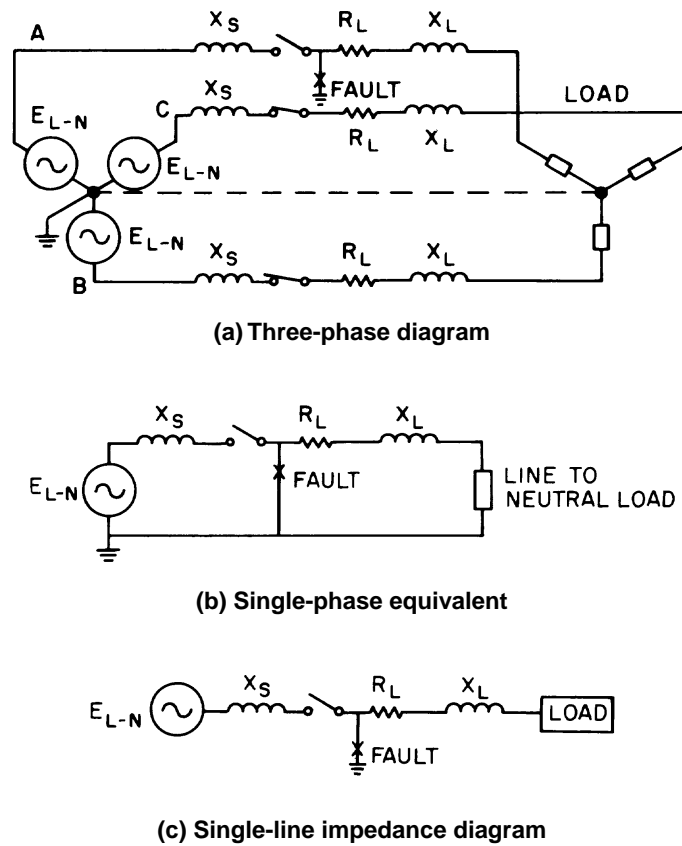

Figure 3-15—A balanced three-phase system with load connected after application of phase A line-ground fault

3.2.9 Symmetrical component analysis

This approach comes to the analyst's rescue when he or she is confronted with an unbalance, the most common circuit condition that invalidates the single-phase equivalent circuit solution method. The symmetrical component analysis allows the response to any unbalanced condition in a three-phase power system to be investigated and correctly synthesized by the sum of the responses to as many as three separate balanced system conditions.

The application of an unbalanced set of voltage phasors, such as those displayed in Figure 3-16, to a balanced downstream load is the sum of the responses of the balanced components that vectorially add to form the original unbalanced set.

Similar conclusions apply when the voltages are balanced, but the connected phase impedances and/or loads and the line currents are unbalanced. Here, the unbalanced current

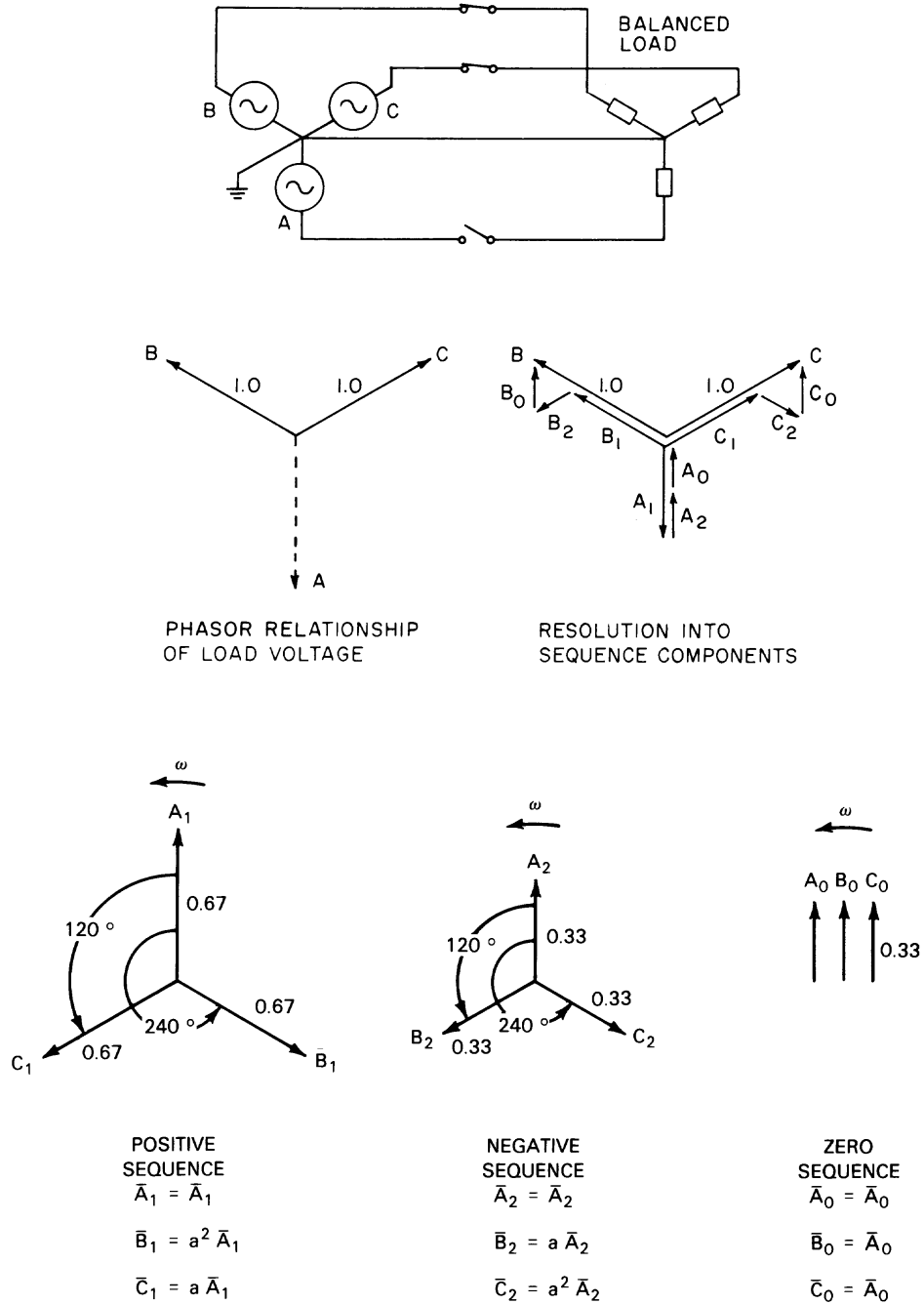

Figure 3-16—Symmetrical component analysis

phasors are the sum of up to three balanced sets that flow through the balanced system impedances on either or both sides of the unbalance, producing voltage drops that satisfy the needs of the applied voltages and the boundary conditions at the point of unbalance.

The mathematical expression for three unbalanced phasors as a function of the balanced phasor components is as follows:

$$\bar{A} = \bar{A}_0 + \bar{A}_1 + \bar{A}_2$$

$$\bar{B} = \bar{B}_0 + \bar{B}_1 + \bar{B}_2$$

$$\bar{C} = \bar{C}_0 + \bar{C}_1 + \bar{C}_2$$

The positive (1), negative (2), and zero (0) sequence vector components of any phase always have the angular relationship with respect to one another as described by the vector diagram and defined by the identities of Figure 3-16.

The operator a causes a counterclockwise rotation through an angle of 120° and is defined as

$$a = 1\angle 120^\circ = -0.5 + j0.866$$

These are assigned a counterclockwise direction of rotation in the *time domain* as illustrated. In the *space domain*, the negative sequence phasors will produce exactly the same results as a set of equal magnitude phasors that are displaced from one another by 120° and that rotate clockwise with time.

The proof that a set of N unbalanced vectors can be completely represented by N sets of balanced vectors is seldom presented in texts dealing with the subject of symmetrical components. The derivation of symmetrical component analysis is most meaningful when applied to three-phase systems, that is, systems where $N = 3$. First, it is postulated that it might be possible to describe three arbitrary but defined vectors, A , B , and C , by summing their respective symmetrical components (as previously shown). Using the vector identities of Figure 3-16, the set of equations for the unbalanced vectors, A , B , and C , can be simplified into the linear set of three equations involving three unknowns as follows:

$$\bar{A} = \bar{A}_0 + \bar{A}_1 + \bar{A}_2$$

$$\bar{B} = \bar{A}_0 + a^2\bar{A}_1 + a\bar{A}_2$$

$$\bar{C} = \bar{A}_0 + a\bar{A}_1 + a^2\bar{A}_2$$

Rearranging, as shown in the following three equations, produces three independent equations for three unknowns (A_0 , A_1 , and A_2), which is everything required to uniquely and com-

pletely describe A_0 , A_1 , and A_2 , and therefore substantiate their existence. The corresponding B and C phase components are defined by the relationships shown in Figure 3-16.

$$\bar{A}_0 = \frac{1}{3}(\bar{A} + \bar{B} + \bar{C})$$

$$\bar{A}_1 = \frac{1}{3}(\bar{A} + a\bar{B} + a^2\bar{C})$$

$$\bar{A}_2 = \frac{1}{3}(\bar{A} + a^2\bar{B} + a\bar{C})$$

The merit of the symmetrical component analysis is that a relatively complicated and often unwieldy problem can be solved by simply vectorially summing the solution to no more than three balanced, independent networks. The three independent networks are referred to as the positive, negative, and zero sequence networks and are illustrated in Figure 3-17 for the system shown in Figure 3-15 prior to application of the line to ground fault. It should be noted in these diagrams that the system voltage source (E_{L-N}) and the load pre-fault open-circuit voltage (V_D) are both balanced, positive sequence voltages, and they appear only in the positive sequence network. Also, the impedance elements the load (R_D , X_D) and the remainder of the system in each network are, as discussed in 3.2.3, intended to represent the Thevenin equivalent impedances at the point in time of interest after the (unbalanced) event.

Typically, the three impedance networks are symbolically represented in shorthand fashion by an empty *block diagram* for the phase most definitive of the condition being studied up to the unbalance or other point of interest, as shown in Figure 3-18. Here, the final interconnections of the networks are shown that satisfy the necessary boundary conditions describing the system at the point of concern in this case, the line-to-ground fault on phase A. In all cases, the analyst can fill the *block diagrams* with the proper sources and impedances, including loads, in each sequence network, properly connect any fault or other impedance involved with the imbalance, and solve the single-phase loop equations. The three current or voltage sequence responses are produced in each of the respective networks, which then add vectorially to produce the resultant responses in the phase represented. The other phase responses then can be obtained by adding vectorially the individual sequence solutions shifted by the appropriate multiple of 120° .

One curious and often confounding feature of this solution procedure is that the phase in the system that usually provides the best, and sometimes the only, approach to the solution for an unbalance is the one least actively involved in the event. The unbalance illustrated in Figure 3-16 is one such example where the solution is obtained through an analysis of the nonconducting phase A. A double line-to-ground fault is another example where examination of the unfaulted phase gives the most direct access to the network solution. With practice evaluating the more commonly encountered unbalances, the analyst can quickly discern the appropriate network interconnection by inspection of the boundary conditions for the event. Several reference texts (Beeman [B1], *Electrical Transmission and Distribution Reference Book* [B4], and Wagner and Evans [B15]) provide convenient diagrams, tables, and other information showing the network interconnections that must be used to solve for the responses to many system unbalances, as well as certain balanced conditions.

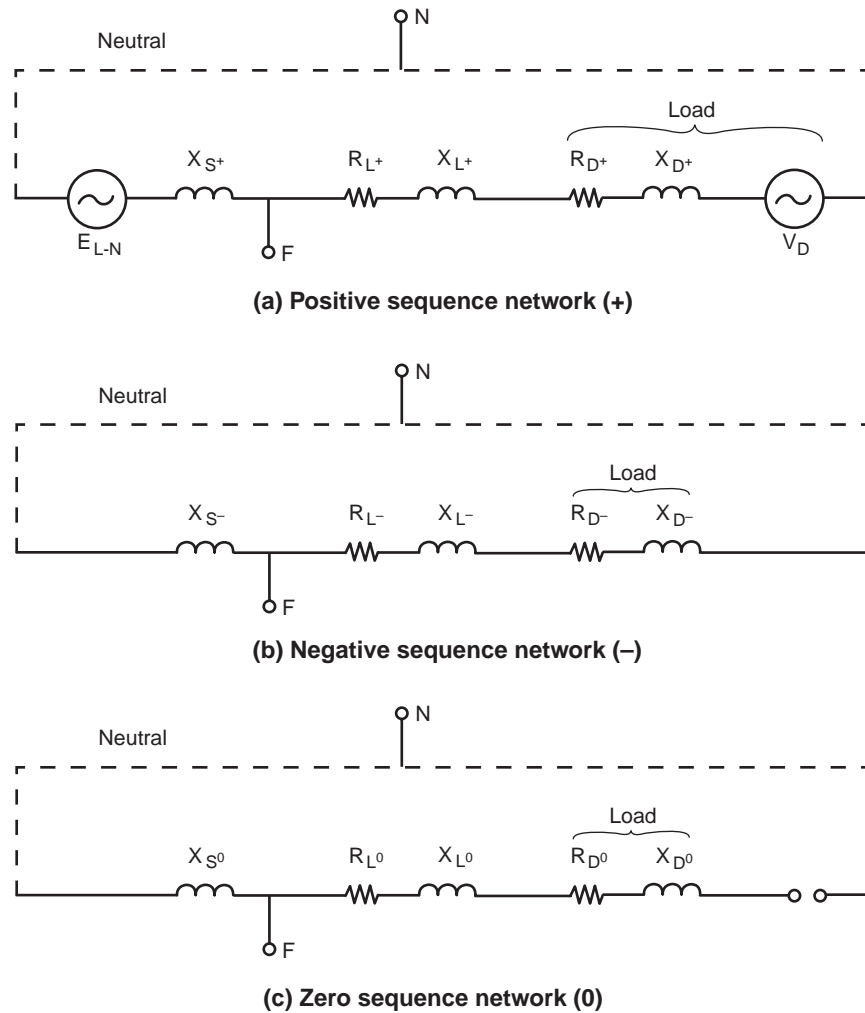
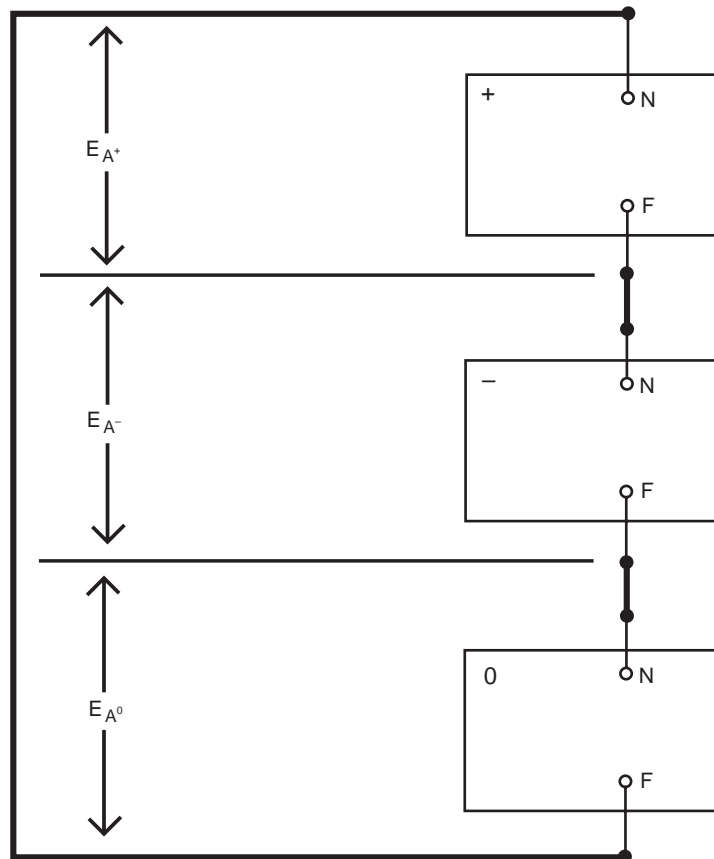

Figure 3-17—Symmetrical component sequence networks for system in Figure 3-15(a) prior to line-ground fault (F) connection

The symmetrical component analysis always involves the use of superposition as well as most of the other procedures previously discussed. The restraints that apply to these other procedures, therefore, must also govern the use of the symmetrical component analysis. In addition, due to mutual phase winding coupling and other effects, the impedance displayed by electrical machines will be different when excited by the different sequence sources. Hence, the *per phase* impedance of circuit elements within the positive, negative, and zero sequence networks will, in general, be different from each other. Currents flowing in the zero sequence network are in phase and do not sum to zero as do the positive and negative sequence currents. Zero sequence currents must therefore flow through the ground circuit and are influenced by any impedance in this circuit path. When harmonic excitation sources are present (requiring the use of the Fourier representation), special care must be exercised in



Boundary Conditions

$$E_A = 0 (= E_{A^+} + E_{A^-} + E_{A^0})$$

$$\begin{aligned} I_B &= 0 \\ I_C &= 0 \end{aligned} \quad (I_{A^+} = I_{A^-} = I_{A^0} = 1/3 I_A)$$

Figure 3-18—Interconnection of Figure 3-17 sequence networks to satisfy Phase A boundary conditions after line-ground fault application

treating the sequence networks. Starting with the fundamental, the harmonic terms progressively shift from the positive to the negative to the zero sequence networks, and then the process repeats.

3.2.10 Per-unit method

The per-unit method of calculation and its close companion, the percentage method, are well documented in Beeman [B1], Stevenson, Jr. [B14], and Weedy [B16] and are generally well-known. As a result, they will only be mentioned in passing here.

Fundamentally, the per-unit method and the percentage method amount to a shorthand calculating procedure for which all equivalent system and circuit impedances are converted to a common kVA and kV_{base}. This permits the ready combination of circuit elements in a network where different system voltages are present without the need to convert impedances each time responses are to be determined at a different voltage level.

Associated with each impedance element and its kVA base is a line-to-line kV base (usually the *nominal* line voltage at which the element is connected to the system), along with the resulting *base impedance* and *base current* related by the following expressions:

a) *Three-phase network*

$$I_{\text{base}} = \frac{\text{kVA}_{\text{base}}}{\sqrt{3} \text{kV}_{\text{base}}}$$

$$Z_{\text{base}} = \frac{\text{kV}_{\text{base}}^2}{\text{kVA}_{\text{base}}} \times 1000$$

$$\text{kVA}_{\text{base}} = \sqrt{3} \text{kV}_{\text{base}} I_{\text{base}}$$

b) *Single-phase network*

$$I_{\text{base}} = \frac{\text{kVA}_{\text{base}}}{\text{kV}_{\text{base}}}$$

$$Z_{\text{base}} = \frac{\text{kV}_{\text{base}}^2}{\text{kVA}_{\text{base}}} \times 1000$$

$$\text{kVA}_{\text{base}} = \text{kV}_{\text{base}} I_{\text{base}}$$

NOTE—Each of the above relationships involving kVA_{base} are sometimes expressed in terms of the corresponding MVA_{base}, where MVA_{base} = kVA_{base}/1000. This results in the convenient expression of kV_{base}²/MVA_{base} for Z_{base} for both three-phase and single-phase networks.

To illustrate the use of the per-unit method, consider the example in Figure 3-19. The first step in a per-unit calculation is the arbitrary selection of the system base kVA. Second, the choice of base kV must be made at one voltage level from which the base value at the other voltage level is dictated by the turns ratios of the transformers in the network. For the circuit in Figure

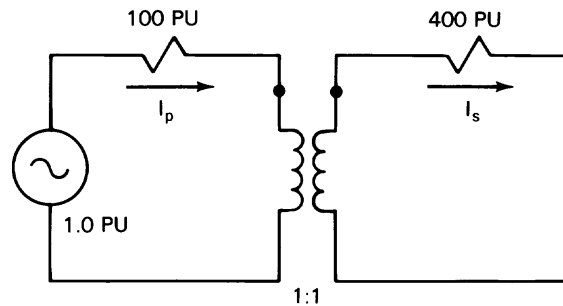
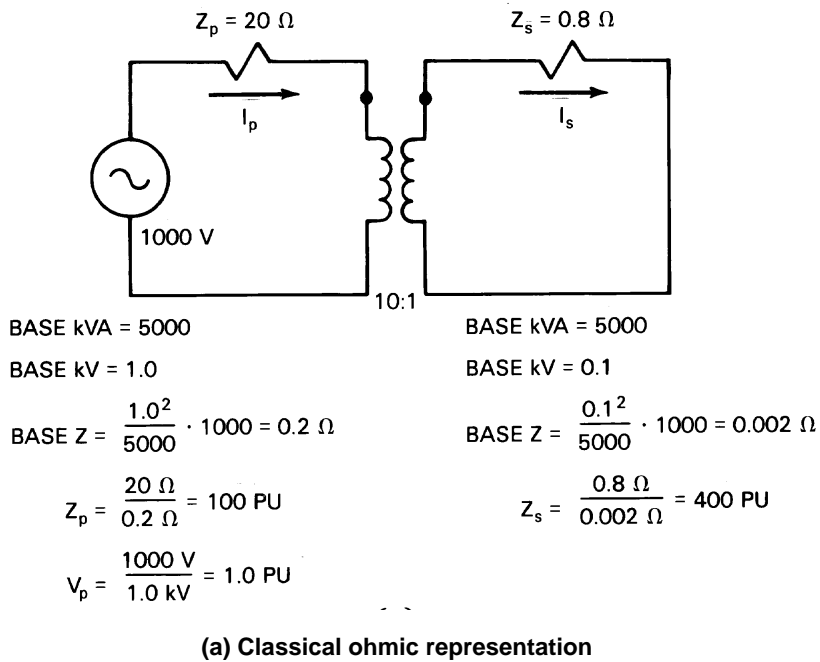
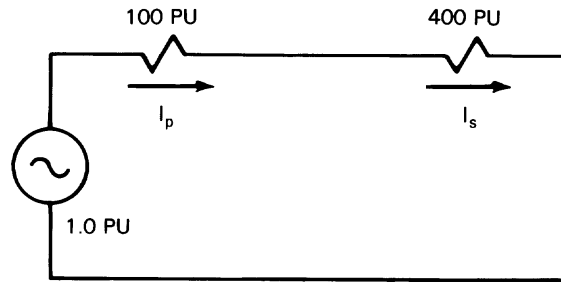

Figure 3-19—Per-unit method at different voltage levels

3-19(a), the base values selected are 5000 kVA and 1.0 kV on the primary of the 10:1 transformer. The resultant base voltage on the secondary of the transformer is 1.0 kV/10 or 0.1 kV. The base impedance can next be calculated (both on the primary and secondary levels) and the per-unit values of the primary and secondary impedances can be determined as shown.

Once the per-unit impedance and excitation source values have been determined, the circuit can be simplified as shown in Figure 3-19(b). A key advantage of the per-unit method, the transformer turns ratio becomes 1:1, thereby effectively removing it from the calculations as



$$I_p = I_s = \frac{V}{Z} = \frac{1.0}{100 + 400} = 0.002 \text{ PU}$$

$$I_{\text{BASE (PRIMARY)}} = \frac{5000}{1.0} = 5000 \text{ A}$$

$$I_{\text{BASE (SECONDARY)}} = \frac{5000}{0.1} = 50\,000 \text{ A}$$

$$I_p = 0.002 \cdot 5000 = 10 \text{ A}$$

$$I_s = 0.002 \cdot 50\,000 = 100 \text{ A}$$

(c) Simplified per-unit representation

Figure 3-19—Per-unit method at different voltage levels (Continued)

modeled in Figure 3-19(c). Working with the circuit in Figure 3-19(c), the primary current (I_p) and secondary current (I_s) are the same and can be easily calculated by simply applying Ohm's law. The last step in the procedure is to determine the actual current in amperes by multiplying each per-unit value by the base current on the primary and secondary levels. Although the per-unit values calculated for I_p and I_s are equal, the base currents are different, and therefore the solutions expressed in amperes are different. Since the per-unit method of calculation is based on the existence of linearity and is always used in combination with one or more of the other principles, it is necessary to observe all of the associated restraints discussed earlier as they apply.

3.3 Bibliography

Additional information may be found in the following sources:

[B1] Beeman, D. (Ed.), *Industrial Power Systems Handbook*, New York: McGraw-Hill, 1955, Chapter 2.

[B2] Blackburn, J. L., *Symmetrical Components for Power Systems Engineering*, Marcel Dekker, Inc., NYC, 1993.

- [B3] Close, C. M., *The Analysis of Linear Circuits*, New York: Harcourt, Brace and World, Inc., 1969.
- [B4] *Electrical Transmission and Distribution Reference Book*, East Pittsburgh, PA: Westinghouse Electric Corporation, 1964, Chapters 2 and 6.
- [B5] Fitzgerald, A. E., and Kingsley, Jr., Charles, *Electric Machinery*, New York: McGraw-Hill, 1961.
- [B6] Goldman, S., *Laplace Transform Theory and Electrical Transients*, New York: Dover Publications, 1966.
- [B7] Hayt, Jr., W. H., and Kemmerly, J. E., *Engineering Circuit Analysis*, New York: McGraw-Hill, 1962.
- [B8] IEEE Std 142-1991, IEEE Recommended Practice for Electric Power Distribution for Industrial Plants (IEEE Red Book), Chapter 4.²
- [B9] Miller, R., *Algebraic Transient Analysis*, San Francisco: Reinhart Press, 1971.
- [B10] Mohamed, E. El-Hawary, *Electrical Power Systems*, IEEE Press, 1995.
- [B11] Nilsson, J. W., *Electric Circuits*, Reading: Addison-Wesley Publishing Co., 1984.
- [B12] Nilsson, J. W., *Electric Circuits*, Reading: Addison-Wesley Publishing Co., 1987.
- [B13] Puchstein, A. F., and Lloyd, T. C., *Alternating Current Machines*, New York: John Wiley and Sons, Inc., 1947.
- [B14] Stevenson, Jr., W. D., *Elements of Power System Analysis*, New York: McGraw-Hill, 1982.
- [B15] Wagner, C. F., and Evans, R. D., *Symmetrical Components*, New York: McGraw-Hill, 1933.
- [B16] Weedy, B. M., *Electric Power Systems*, New York: John Wiley and Sons, Inc., 1972, Chapter 2.

²IEEE publications are available from the Institute of Electrical and Electronics Engineers, 445 Hoes Lane, P.O. Box 1331, Piscataway, NJ 08855-1331, USA.

Chapter 4

System modeling

4.1 Introduction

This chapter addresses the following questions:

- a) How can each component or each group of components of an industrial or commercial power system be represented so that an analysis of the system performance can be made?
- b) Which of the several possible representations, or models, of the system is best suited to meet the objectives of a given study?
- c) What mathematical expressions will describe the characteristics of each system element so that it can be quantified and programmed for computer input?

There is an infinite number of possible power system configurations and a large variety of study types. Consequently, standards cannot be established to dictate specific models for all specific circumstances. This text will therefore serve as a guide to help the reader make judicious trade-offs in selecting models for a study.

Derivations and proofs of mathematical expressions will not be given. References should be used for such purposes. However, several fundamental relationships of electrical and mechanical quantities will be mentioned in the text. This should save the reader the time needed to locate them in textbooks or handbooks. It should also help refresh the memories of those who have not been exposed to power studies or academic activities for a long time.

The material is intended to be as basic and simple as permitted by the subject. The emphasis is on the correlation of real-life systems with the abstraction of mathematics in order to facilitate computer simulations of these systems.

4.2 Modeling

Scale modeling of power systems as a means of analyzing their performance is impractical. However, scale models of certain mechanical components of power systems are used to evaluate their characteristics. This is often the case with hydraulic sections of hydroelectric plants, such as turbine runners, spiral cases, gates, draft tubes, etc. Nonetheless, much expertise is required to establish scaling and normalization factors, to construct the model, to gather meaningful data by measurement, and to interpret and extrapolate the results.

Digital computers can be programmed to solve large numbers of simultaneous equations quickly and inexpensively and handle the algebra of large matrices. This makes them particularly well suited for applications in power system analysis. An immense variety of programs have been written to study an ever-increasing number of problems in the electrical field. These programs are usually set up to receive the problem information in the form of numbers rather than analog settings, thus forcing the power system analyst to model the system quantitatively. The data input portions of these programs are typically written in general, nonspecific terms. This exposes the analyst to a choice of program features and alternatives that require decisions to be made every step of the way. Finally, the programs are often structured to handle extensive power systems (3000 bus programs are not uncommon).

4.3 Review of basics

Power network elements may be classified in two categories, passive elements and active elements.

4.3.1 Passive elements

The passive elements comprise such components as transmission lines, transformers, reactors, and capacitors. They will, in general, be regarded as linear and will be modeled by one or more of the following electrical quantities:

Name	Symbol	Unit
resistance	R	ohm
inductance	L	henry
capacitance	C	farad

The voltage across and the current through the element will be governed by these relationships:

$$v = Ri \quad i = \frac{v}{R} \quad (4-1)$$

$$v = L \frac{di}{dt} \quad i = \frac{1}{L} \int v dt \quad (4-2)$$

$$v = \frac{1}{C} \int i dt \quad i = C \frac{dv}{dt} \quad (4-3)$$

where the lowercase letters represent the time-varying functions of voltage and current. In dc circuits under steady-state conditions, these equations will reduce to

$$\begin{aligned}
 V &= RI & I &= \frac{V}{R} \\
 V &= 0 & \left(\text{since } \frac{di}{dt} = 0 \right) \\
 I &= 0 & \left(\text{since } \frac{dv}{dt} = 0 \right)
 \end{aligned} \quad (4-4)$$

In ac circuits with sinusoidal wave shapes, the equations become

$$V = RI \quad I = \frac{V}{R}$$

$$V = jX_L I$$

where $X_L = 2\pi fL$ is the inductive reactance (4-5)

$$V = -jX_C I$$

where $X_C = \frac{1}{2\pi fC}$ is the capacitive reactance (4-6)

The capital letters for voltages and currents represent their rms values, f is the frequency in hertz, and j is the 90° operator ($=\sqrt{-1}$). Inverting and combining these elements in series or parallel will define the set of quantities in Table 4-1.

Table 4-1—Equation references for conductance, susceptance, impedance and admittance

Name	Symbol	Unit	Defining expression
conductance	G	S (siemens)	$1/R$
inductive susceptance	B	S (siemens)	$1/X$
capacitive susceptance	B	S (siemens)	$1/X$
impedance	Z	Ω (ohms)	$(R + jX)$
admittance	Y	S (siemens)	$(G + jB)$

It should be noted here that it is customary in ac power circuits to use the R , X , and Z quantities for the series (line) elements and the G , B , and Y quantities for the shunt (line to neutral) elements. Note also that Z and Y are complex quantities that can be expressed in the rectangular form above or the polar form $Z = |Z|\angle\theta$ or $Y = |Y|\angle\theta$. Most computer programs accept the Z and Y values in the rectangular form.

A final remark concerns the sign ahead of the reactances and susceptances. The four diagrams in Figure 4-1 are self-explanatory. The wise analyst will verify the program instructions to make sure that the computer will interpret the input data properly.

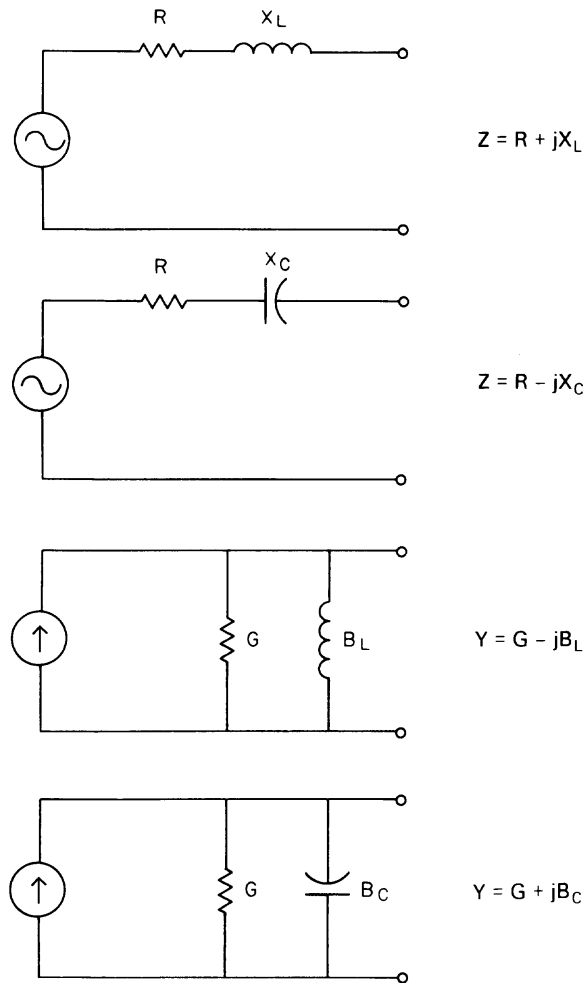

Figure 4-1—Equivalent circuit diagrams showing sign convention

4.3.2 Active elements

The active elements of a power system comprise such components as motors, generators, synchronous condensers, and other loads such as furnaces, adjustable speed drives, etc. The active elements will be regarded as nonlinear, although some of the components may behave linearly under certain circumstances.

One or more of the parameters of a model of an active element will vary as a function of time, phase angle, frequency, speed, etc.

The four expressions for power quantities given in Table 4-2 can be used to model nonlinear elements. Given any two of the four values, the remaining two can be defined. Power can also be expressed in polar form: $S = |S|\angle\theta$ which yields these relationships: $\text{PF} = \cos \theta$, $P = S \cos \theta$, and $Q = S \sin \theta$. Note that the magnitude of the complex power must be used in the previous equations and in the relations of table below.

Note that the signs of P or Q may be positive or negative. By convention, the positive sign of Q is used for inductive loads; that is, the current will lag the voltage applied to a load that consumes vars. In this sense, it is said that capacitors generate vars (current leads the voltage) and that induction motors absorb vars.

Table 4-2—Four defining expressions for power quantities

Name	Symbol	Unit	Defining expression
complex power	S	voltampere (VA)	$S = P + jQ$
active power	P	watt (W)	$P = \sqrt{S^2 - Q^2}$
reactive power	Q	var	$Q = \sqrt{S^2 - P^2}$
power factor	PF	per unit (pu)	$\text{PF} = P/S$

By convention also, the sign of P is positive for a load that consumes energy or a source that generates energy. Thus a load with a negative sign for P could be used to represent a generator, and vice versa for a motor. It should also be noted that the expressions above are appropriate for fundamental frequency applications only; modifications are required for application in harmonic analyses.

Some of the power system components can best be expressed in terms of current or voltage. For instance, an infinite bus may be specified by a voltage source of constant magnitude and angle, and a particular load may be described as a constant current element. The current and voltage quantities may be complex numbers, in which case they have to be described in terms of a reference vector that may be a voltage or current quantity.

This introduces the phase angle concept:

$$I = |I|\angle\theta = I_x + jI_y = I(\cos \theta + j\sin\theta)$$

$$V = |V|\angle\theta = V_x + jV_y = V(\cos \theta + j\sin\theta)$$

where the x axis of the coordinate system is taken as the reference shown in Figure 4-2.

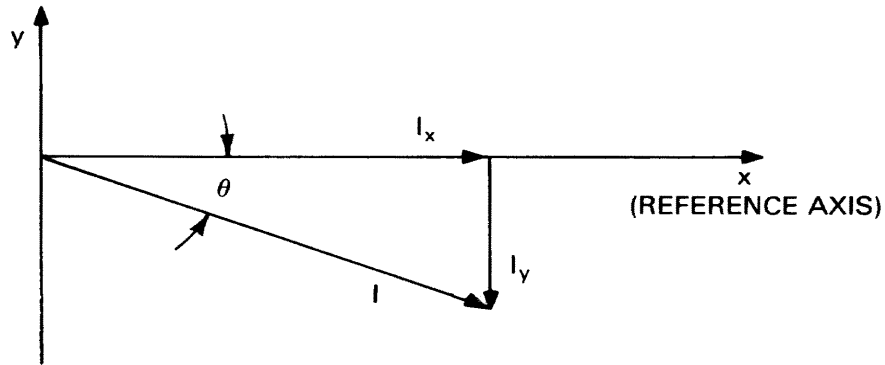

Figure 4-2—Vector diagram

So far, the review has included most of the quantities used in the type of studies that require steady-state network solutions at a single point in time. It should be noted that multiple applications, each appropriate for a different point in time, of these steady-state concepts may be used to analyze certain system conditions that are time-varying (e.g., fault calculations).

Some studies, such as motor-starting and transient stability, require that a complete period of time be covered to assess the effects of a disturbance on system performance. This requirement that a certain period of time be considered introduces the need for mechanical quantities.

The fundamental quantities of mechanics are space, matter, and time. Other mechanical quantities are derived from these three. Some of the derived quantities officially recognized for electrical engineering work have been tabulated in Table 4-3, which shows the MKS system of units and the defining equations.

Table 4-3—Fundamental equations for translation and rotation

Name	Symbol	Unit	Defining expression
Fundamental			
length	l	meter (m)	—
mass	m	kilogram (kg)	—
time	t	second (s)	—
Translation			
velocity	v	m/s	$v = \frac{dl}{dt}$

Table 4-3—Fundamental equations for translation and rotation (Continued)

Name	Symbol	Unit	Defining expression
acceleration	a	m/s^2	$a = \frac{d^2l}{dt^2}$
force	F	newton (N)	$F = ma$
work	W	joule (J)	$W = \int Fdl$
power	P	watt (W)	$P = \frac{dW}{dt}$
momentum	M'	N/s	$M' = mv$
Rotation			
radius	r	m	–
circular arc	s	m	–
moment of inertia	I	$\text{kg}\cdot\text{m}^2$	$I = \int r^2 dm$
angle	θ	radian (rad)	$\theta = s/r$
angular velocity	ω	rad/s	$\omega = \frac{d\theta}{dt}$
angular acceleration	α	rad/s^2	$\alpha = \frac{d^2\theta}{dt^2}$
torque	T	N·m	$T = rF$
work	W	J	$W = \int Td\theta$
power	P	W	$P = T\omega$
angular momentum	M	J·s/rad	$M = I\omega$

4.4 Power network solution

Before dealing with the detailed models of power system components, it is important to review what constitutes the solution of a network. From an electric circuits point-of-view, it can be said that a network is solved if all the bus voltages and the relative phase angles between these voltages are known. In this case, solved means that all other network voltages, currents, and power flows can be calculated from the known bus voltages using simple algebraic equations. This, of course, requires that the impedances between the buses be known. Note, however, that the solution for the set of bus voltages can be a formidable problem, and the methods used to obtain this solution vary depending on the type of analysis.

Consider for instance Figure 4-3, which shows a small simplified section of the typical plant from the one-line diagram (Figure 1-1) in Chapter 1.

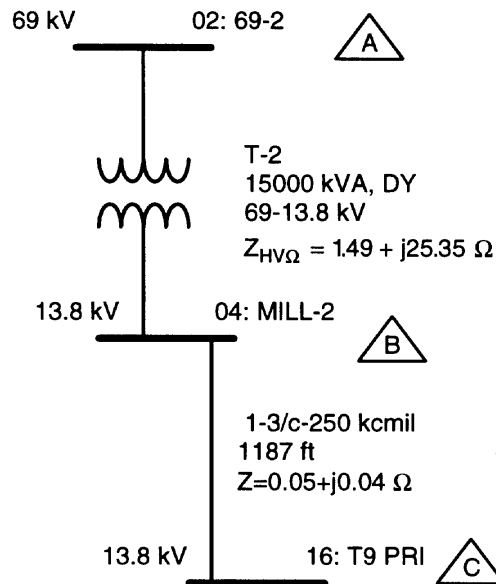

Figure 4-3—Simplified one-line diagram

To demonstrate typical calculations, assume that the voltages at buses 02:69-02, 04:MILL-2, and 16:T9 PRI (called A, B, and C, respectively, to simplify notation) are known. The impedances of the transformer T-2 and the cable from 04: MILL-2 (B) to 16: T9 PRI (C) are given on Figure 4-3.

These data are summarized in Figure 4-4 and are listed as follows:

$$V_{02:69-2} = V_A = 69.00 \text{ kV} \angle 0^\circ$$

$$V_{04:MILL-2} = V_B = 13.60 \text{ kV} \angle -1.6^\circ$$

$$V_{16:T9 \text{ PRI}} = V_C = 13.57 \text{ kV} \angle -1.82^\circ$$

$$Z_{T-2} = Z_{AB} = 1.49 + j25.35 \Omega \text{ (at 69 kV)} = 0.06 + j1.01 \Omega \text{ (at 13.8 kV)}$$

$$Z_{\text{CABLE}} = Z_{BC} = 0.05 + j0.04 \Omega$$

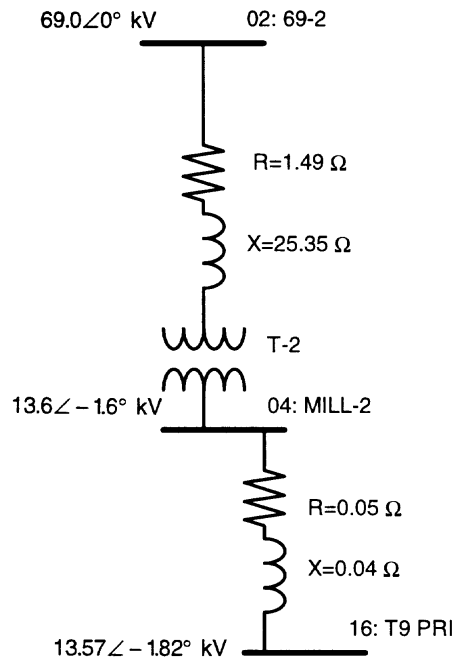

Figure 4-4—Impedance diagram with numerical data

The current from bus A to bus B can be found by

$$\begin{aligned}
 I_{AB} &= (V_A - V_B) / (Z_{AB} \sqrt{3}) \\
 &= \frac{69\,000 \angle 0^\circ - \frac{69}{13.8} 13\,600 \angle -1.6^\circ}{\sqrt{3}(1.49 + j25.35)} \\
 &= 49.07 \angle -25.03^\circ \text{ A (at 69 kV)}
 \end{aligned} \tag{4-7}$$

By definition, the power flow from bus A to bus B, as measured at bus A, is

$$\begin{aligned}
 S_{AB} &= \sqrt{3} V_A \times \hat{I}_{AB} \text{ (the caret on } \hat{I} \text{ means } \textit{conjugate})} \\
 &= (\sqrt{3} \times 69 \angle 0^\circ)(49.07 \angle +25.03^\circ)
 \end{aligned} \tag{4-8}$$

$$\begin{aligned}
 &= 5864.4 \angle 25.03^\circ \text{ kVA} \\
 &= (P_{AB} + jQ_{AB}) \\
 &= 5313.68 + j2481.19 \text{ kVA}
 \end{aligned}$$

The current I_{AB} on the 13.8 kV side is equal to that at the 69 kV side multiplied by the transformer turns ratio:

$$\begin{aligned}
 I_{AB} &= 49.07 \angle -25.03^\circ \left(\frac{69}{13.8} \right) \\
 &= 245.37 \angle -25.03^\circ \text{ (at 13.8 kV)}
 \end{aligned}$$

By definition, the power flow from bus B to bus A, as measured at bus B, is

$$\begin{aligned}
 S_{BA} &= \sqrt{3} V_B \times (\hat{I}_{BA}) \\
 &= (\sqrt{3} \times 13.60 \angle -1.6^\circ) \times (-245.37 \angle 25.03^\circ) \\
 &= -5779.9 \angle 23.43^\circ \text{ kVA} \\
 &= P_{BA} + jQ_{BA} \\
 &= -5303.34 - j2298.25 \text{ kVA}
 \end{aligned}$$

The transformer real and reactive power losses can now be found by adding the power from A to B and that from B to A:

$$\begin{aligned}
 S_{\text{losses}} &= S_{AB} + S_{BA} \\
 &= (5313.68 + j2481.19) + (-5303.34 - j2298.25) \\
 &= 10.34 + j182.95 \text{ kVA}
 \end{aligned}$$

The losses are 10.34 kW and 182.95 kvar between buses A and B. Figure 4-5 summarizes these results. This example illustrates that once the bus voltages are known, the remaining calculations are straightforward.

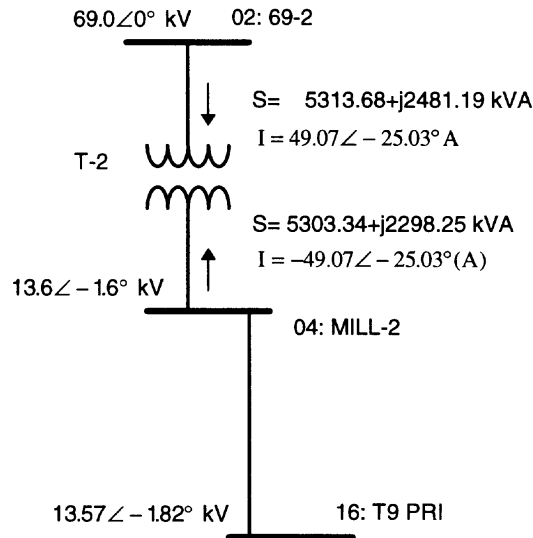

Figure 4-5—Current and complex power flows

The problem of analyzing even a modest size system involves the determination of the bus voltages. The loads are known but they are often a nonlinear function of the applied voltage. In order to find the bus voltages, one has to resort to a cut-and-try iterative method. The computer is an effective tool for this method because it can complete the set of calculations shown above much faster than if done by hand.

4.5 Impedance diagram

Several things remain to be said about Figures 4-3 through 4-5:

- a) All three diagrams show a single-phase equivalent of the three-phase system. The conditions for this equivalence to be true were covered in Chapter 3.
- b) Bus and line designators have been shown on all three diagrams. The impedance diagram of Figure 4-4 is the rigorously correct way to represent graphically resistances and reactances. However, it is felt that drawing the graphical symbols of resistances, inductances, and capacitances is superfluous since the expressions for impedances along side a straight line sufficiently describe the line elements. Rough drawings, such as that in Figure 4-3, showing buses, lines, generators, and loads, can be duplicated for multiple use as an impedance diagram and as a flow diagram. It should be noted that these diagrams are working tools and as such do not require standardization. However, the analyst should adopt a method suitable for keeping track of masses of data, for even small system studies require and generate a large amount of information.

- c) In power systems analysis, the term *bus* does not always have the meaning understood by a plant electrician, for instance. The analyst calls a *bus* any point of the system where voltages are calculated. The term is interchangeable with *node*. Fictitious buses may be introduced on the network to obtain voltage solutions at certain points of interest. An example of this may be a 150 mi transmission line broken down in 5 sections of 30 mi (that is, a bus introduced every 1/5 of the length) in order to avoid the complicated but exact model of the long line. Conversely, a single bus (node) in the model may represent what the electrician would call several buses. Examples might included “buses” connected with normally closed breakers or very short lengths of cables.
- d) In the same vein, *branches* are used to represent types of different equipment connecting buses (nodes). In general, a branch is any element between two nodes. For example, the transformer data will be entered on a computer input document called “branch data.” In many cases, the terms *line* and *branch* are used interchangeably.

4.6 Extent of the model

4.6.1 General

No rigid rules can be established on how much of a power system should be modeled for a given study. System analysts have to exercise judgment and develop a feel for this as they gain experience. In general, the objectives of the study should always be kept in focus to avoid unnecessary effort that could be spent modeling certain aspects of the system that are not pertinent to the analysis to be conducted.

4.6.2 Utility supplied systems

A large number of industrial and commercial establishments are supplied by stiff utility systems. Stiffness is a relative function of the size of the plant load and local generation. If the external power system or utility is large compared with that of the plant, disturbances within the plant do not affect the voltage at the point of connection. In such a case, the utility system is said to be an infinite system. The connection point will be an infinite bus.

This concept can be extended within the plant electrical distribution system when studies are concerned with small areas electrically remote from the utility supply. Conversely, sections of utility systems may require modeling in cases where this stiffness does not exist. It is, therefore, important that a sound knowledge of the utility supply systems be acquired before proceeding with the studies.

4.6.3 Isolated systems

Determining whether an isolated system should be modeled in full or in part is easier than with a complex interconnected system. These systems are usually relatively small and, as such, could be represented fully for most kinds of studies. The extra effort of gathering a set of data for the entire system, even though a smaller section would suffice, will not be lost since the additional data will likely be used in some future study. The nature of an isolated system is such that a modification or a disturbance is more apt to be felt throughout the system.

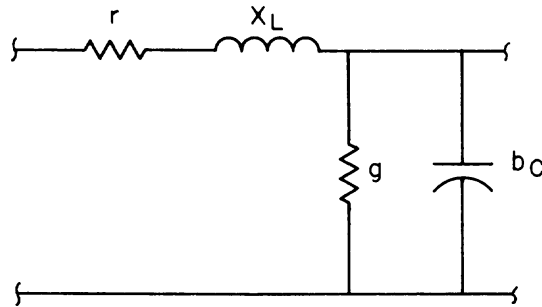

Figure 4-6—Equivalent circuit of short conductor

4.7 Models of branch elements

4.7.1 Lines

Four parameters affect the performance of the conductors connecting a source to a load: series resistance, series inductance, shunt capacitance, and shunt conductance. These parameters affect both overhead lines and cables and the same calculation procedures are used to determine parameter values in each case. For this reason, it is common to use the word *line* to represent both overhead lines and cables. Note that certain assumptions that are valid for widely spaced conductors used in overhead lines may not be valid for the much closer conductor arrangements found in cables. Conductor length, however, affects overhead lines and cables in the same way.

A short conductor can be modeled as in Figure 4-6. A line can be considered as many short conductors placed in series to yield the model of Figure 4-7. The individual lengths of each conductor could be made shorter thus increasing the number of these conductors for a given length of line. Continuing this process to the limit defines the model called the distributed-parameter line model. This model has been reduced to the equivalent circuit shown in Figure 4-8, where the series branch is defined by

$$Z' = Z_C \frac{\sinh \gamma l}{\gamma l} \quad (4-9)$$

and the shunt branches by

$$\begin{aligned} \frac{Y'}{2} &= \frac{Y_C}{2} \frac{\tanh(\gamma l/2)}{\gamma l/2} \\ &= \frac{1}{Z_C} \frac{(\cosh \gamma l - 1)}{\sinh \gamma l} \end{aligned} \quad (4-10)$$

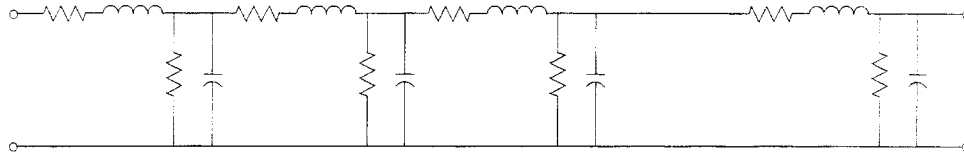

(a) Line with distributed constants

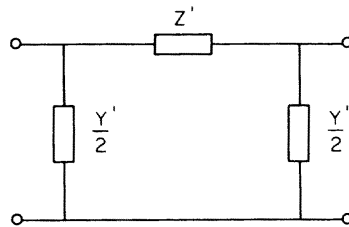

$$Z' = \frac{Z_c \sinh \gamma \ell}{\gamma \ell}$$

$$Y' = \frac{Y_c \tanh (\gamma \ell / 2)}{(\gamma \ell / 2)}$$

(b) Long line equivalent circuit

Figure 4-7—Equivalent line models

Two figures of merit appear in these equations:

$$Z_C = \sqrt{z/y}, \text{ defined as the characteristic or surge impedance of the line} \quad (4-11)$$

$$\gamma = \sqrt{yz}, \text{ defined as the propagation constant} \quad (4-12)$$

Both Z_C and γ are complex numbers. The propagation constant γ can be expressed in the rectangular form:

$$\gamma = \alpha + j\beta \quad (4-13)$$

This defines

- α is the attenuation constant
- β is the phase constant (in radians)

The other variables are

- l is the total length of line,
- r is the conductor effective resistance in ohms per unit of length,
- x is the conductor series inductive reactance in ohms per unit of length
 $x = 2\pi fL,$
- g is the shunt conductance to neutral in siemens per unit of length,

- b is the shunt capacitive susceptance in siemens per unit of length
 $b = 2\pi fC$,
 L is the conductor total inductance in henrys per unit of length,
 C is the conductor shunt capacitance in farads per unit of length,
 $z = r + jx$ is the series impedance in ohms per unit of length,
 $y = g + jb$ is the shunt admittance to neutral in siemens per unit of length,
 $Z = zl$ is the total series impedance of line in ohms,
 $Y = yl$ is the total shunt admittance of line to neutral in siemens per unit of length,
 \sinh , \cosh , \tanh are hyperbolic functions.

These functions of complex numbers can be evaluated by using the following relationships:

$$\sinh(\gamma l) = \sinh(\alpha l + j\beta l) = \sinh(\alpha l)\cos(\beta l) + j\cosh(\alpha l)\sin(\beta l) \quad (4-14)$$

$$\cosh(\gamma l) = \cosh(\alpha l)\cos(\beta l) + jsinh(\alpha l)\sin(\beta l) \quad (4-15)$$

$$\tanh X = \frac{\sinh X}{\cosh X} \quad (4-16)$$

$$\sinh(\alpha l) = \frac{e^{\alpha l} - e^{-\alpha l}}{2} \quad (4-17)$$

$$\cosh(\alpha l) = \frac{e^{\alpha l} + e^{-\alpha l}}{2} \quad (4-18)$$

The surge impedance Z_C is approximately 400 Ω for typical single circuit overhead power lines, while typical cable circuits have a surge impedance of 30–40 Ω . The distributed constants model is valid for short or long lines at power or communication frequencies.

4.7.1.1 Long lines

Power frequency overhead lines in excess of 150 mi should be represented by the distributed constants model reduced to an equivalent π as shown in Figure 4-7 (b).

The shunt conductance g may be neglected because the dielectric is air (a good dielectric) and the conductor spacing is large. However, if the corona losses are important, they may be represented by g . Computer programs will readily accept the data for Z' expressed in the rectangular form, that is, the equivalent series resistance R' and the equivalent series inductive reactance X' . It should be noted that even though g is neglected ($g = 0$), a nonzero value of G' will appear in the equivalent circuit of Figure 4-8 (b). The values of $G'/2$ and $B'/2$ (in siemens) may have to be modified to MW or Mvar to suit the program input requirements. (The computer treats them as constant impedance loads.) If the computer requires a *line charging Mvar*, the value B' and not $B'/2$ must be used to calculate

$$\text{Mvar} = 3(\text{kV}_{ln})^2 \times B' \quad (4-19)$$

The program will internally assign half of that value to the bus at each end of the line.

The value of $G'/2$ can be modified to

$$MW = 3(kV_{ln})^2 \times \frac{G'}{2} \quad (4-20)$$

and input as a constant impedance bus load.

The voltage (kV) is the line-to-ground voltage corresponding to the base voltage used in the program input document.

4.7.1.2 Medium lines

In the range of approximately 50–150 mi (80–240 km), little accuracy is lost by simplifying Equation (4-9) and Equation (4-10) to

$$Z' = Z$$

$$\frac{Y'}{2} = \frac{Y}{2}$$

$$\sinh(\gamma l)/\gamma l = 1$$

Thus, neglecting the products $\sinh(\gamma l)/\gamma l$ and $\tanh(\gamma l/2)/(\gamma l/2)$ yields the model of Figure 4-8 (a), called the nominal π circuit. In this model, the shunt branches are purely capacitive (no conductance).

The nominal π circuit can be thought of as being formed by the process described at the beginning of 4.7.1, except that the unit length of conductor is increased (instead of decreased), and the circuit is made symmetrical (bilaterally). This results in the constants being lumped by an approximation process. The nominal T circuit is formed the same way, except that all the shunt constants are lumped together compared with the π circuit where all series constants are lumped together.

Use of the nominal T model [Figure 4-8 (b)] is not popular since it requires addition of a fictitious bus in the middle of the line. Entering data into the program for the nominal π circuit follows the same requirements as for the long line model.

4.7.1.3 Short lines

For overhead lines shorter than 50 mi, neglecting the shunt capacitance in the models presented earlier will not greatly affect the results of load flow, short-circuit, or stability calculations. This yields the model of Figure 4-9.

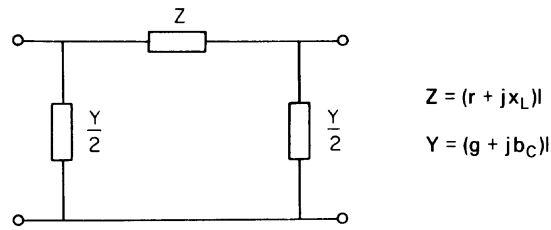

$$Z = (r + jx_L)\ell$$

$$Y = (g + jb_C)\ell$$

(a) Nominal π

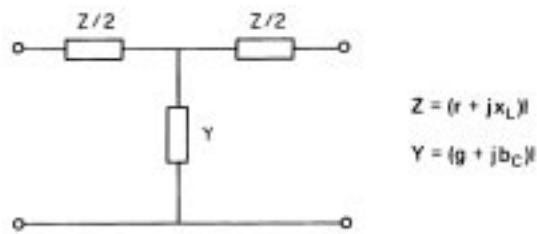

$$Z = (r + jx_L)\ell$$

$$Y = (g + jb_C)\ell$$

(b) Nominal T

Figure 4-8—Medium line equivalent circuits

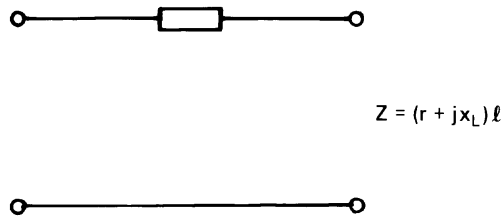

$$Z = (r + jx_L)\ell$$

Figure 4-9—Short line equivalent circuit

4.7.2 Cables

The overhead line models are equally applicable to cables. Though the resistances are substantially the same, the relative values of reactances are vastly different. Table 4-4 compares two cases, one at 69 kV, the other at 13.8 kV. The cable inductive reactance is about 1/4 that of the line; but the capacitive reactance is 30–40 times that of the line.

This comparison suggests that, for fundamental frequency, the medium line model, the nominal π , should be used for cables in the order of one mile in length (approximately 1/40 of 50 mi). The shorter the cable run, the better the accuracy when using this model.

Table 4-4—Comparison of overhead lines and cable conductors

	Values in Ω /mile (Ω /km) for 500 kcmil Cu conductors			
	69 kV		13.8 kV	
	Overhead line ^a	Cable ^b	Overhead line ^c	Cable ^d
Resistance	0.134 (0.083)	0.134 (0.083)	0.134 (0.083)	0.134 (0.083)
Inductive resistance	0.695 (0.432)	0.175 (0.109)	0.613 (0.381)	0.146 (0.091)
Capacitive reactance	$0.005 (0.008) \times 10^6$	$0.162 (0.026) \times 10^6$	$0.003 (0.005) \times 10^6$	$0.142 (0.229) \times 10^6$

^aOpen-wire equilateral conductor spacing of 8 ft

^bThree-conductor oil-filled paper-insulated cable rated 69 kV

^cOpen-wire equilateral conductor spacing of 4 ft

^dThree-conductor oil-filled paper-insulated cable rated 15 kV

It is doubtful that any medium voltage system will have feeder lengths requiring representation of the capacitive reactance.

4.7.3 Determination of constants

Electrical conductor characteristics are available from numerous sources and need not be repeated here. A few general comments are appropriate.

4.7.3.1 Resistance

The *effective resistance* of the conductors should be used. The effective resistance takes into account the conductor:

- a) Material
- b) Size
- c) Shape
- d) Temperature
- e) Frequency
- f) Environment

Copper and aluminum are the most used conductor materials for lines and cables. Soft annealed chemically pure copper has 100% conductivity (IACS standards).

This is equivalent to 875.2 Ω for a 1-mile-long round wire weighing one pound at 20 °C. All other materials can have their conductivities expressed as a percentage of the standard, a few of which are listed in Table 4-5.

Table 4-5—Conductor data

Material	Conductivity	Application
Copper		
soft	100	cable construction
soft, tinned	93.15 to 97.3	cable construction
hard, shape	98.4	bus bar
hard, round	97.0	overhead line conductors
Aluminum	61.0	cables, bars, tubes
Aluminum alloys		
5005-H19	53.5	overhead line conductors
6201-T81	52.5	overhead line conductors
Galvanized steel		
Siemens-Martin	12.0	shield wire
high-strength	10.5	shield wire
extra-high-strength	9.4	shield wire

The conductor resistance will vary with temperature according to the following formula:

$$R_2 = R_1[1 + \alpha(t_1 - t_2)] \quad (4-21)$$

where

R_2 is the resistance at temperature t_2

R_1 is the resistance at temperature t_1

α is the temperature coefficient per degree at temperature t_1

At 20 °C, the coefficient α per degree Celsius is as follows:

- Copper: 0.00393
- Aluminum: 0.00403
- Galvanized steel:
 - Siemens-Martin: 0.0039
 - High-strength: 0.0035
 - Extra-high-strength: 0.0032

It is not possible to predict the exact operating conductor temperature if the conductor current is not known. The analyst has the choice of either estimating the conductor temperature or assuming the worst case, which, in some studies, might be the maximum allowable temperature of the cable. Other studies might require that the minimum conductor temperature be used for the worst case.

The ac resistance of conductors is higher than the dc resistance due to skin effects. The effect is more pronounced as the conductor cross section or the operating frequency increases. Conductor data tables usually include ac resistances at power frequencies. The skin effect is a major factor in the design of high-current (several thousand amperes) ac bus systems, such as those for electric furnaces.

The flux established by alternating current in a conductor may link other conductors or metallic masses in its proximity thus generating voltages in those parts. These voltages may cause currents to flow through closed circuits and thus cause I^2R losses other than those of the conductor itself. These losses can be represented as an additional component of resistance in series with the conductor resistance. The reader should consult the *Electrical Transmission and Distribution Reference Book* [B5]¹ and Puchstein and Lloyd [B20] for information on this subject.

4.7.3.2 Inductive reactance

The inductive reactance of a circuit has two components: that due to its own circuit (self) and that due to other circuits in its vicinity (mutual). The inductance of a conductor also has two components: that caused by the current in itself, and that caused by the currents in other conductors of the same circuit. Finally, the inductance of a conductor due to its own current is divided in two parts: the first part considers the flux internal to the conductor; the second part considers the flux external to the conductor. This last division has been modified to simplify tables of conductor characteristics.

There are two types of tables commonly used to determine the inductive reactance of a conductor. One table lists the conductor inductive reactance X_s at one foot spacing even if the actual spacing is larger or smaller than one foot. A second table, valid for any type or size of conductor, lists spacing factors X_d which, when added to the one foot (0.3048 m) reactance, will give the correct total reactance for the given circuit conductor spacing.

The spacing factor table is calculated from the following equation:

$$X_d = 4.657 \times 10^{-3} \times f \times \log \text{ GMD}$$

$$X_d = \frac{\Omega}{(\text{conductor} \times \text{mile})} \quad (4-22)$$

¹The numbers in brackets correspond to those of the bibliography in 4.11.

where

GMD is the geometric mean distance of the conductors

For three conductors spaced d_1, d_2, d_3 ,

$$\text{GMD} = \sqrt{d_1 \times d_2 \times d_3}$$

Note that in Equation (4-22) a GMD smaller than 1 yields a negative spacing factor.

Cables in steel conduit exhibit higher reactances than those in free air. The calculations are too complex to develop by hand; hence, the tables in Chapter 1 of the *Industrial Power Systems Handbook* [B16] should be used for estimating purposes.

4.7.3.3 Shunt capacitive reactance

Capacitive reactance can be determined in a similar fashion. Conductor tables give the value of reactance X_s at one foot spacing. A spacing factor X_d is added to X_s to yield the total capacitive reactance of the conductor. Spacing factor tables are calculated from

$$\begin{aligned} X'_d &= \frac{4.099}{f} \times 10^{-6} \log \text{GMD} & (4-23) \\ &= \Omega - \text{mile/conductor} \end{aligned}$$

The capacitive reactance of shielded cables is determined from

$$\begin{aligned} X'_c &= \frac{1.79G \times 10^6}{f \times k} & (4-24) \\ &= \Omega - \text{mile/conductor} \end{aligned}$$

where

G is the geometric factor
 k is the dielectric constant of cable insulation
 f is the frequency

$$G = 2.303 \log \frac{2r}{d} \quad (4-25)$$

where

r is the inside diameter of shield
 d is the outside diameter of conductor

Typical values of k are 6.0 for rubber, 5.0 for varnished cambric, 2.6 for polyethylene, and 3.7 for paper.

4.7.4 Reactors

Reactors are used as branch elements in the following applications:

- a) To limit current during fault conditions;
- b) To buffer cyclic voltage fluctuations caused by repetitive loads (in conjunction with condensers);
- c) To limit motor-starting currents.

Reactors are modeled as impedances consisting of an inductive reactance in series with a resistance expressed as $R + jX$. Manufacturers' design or test data should be obtained for existing installations.

4.7.5 Capacitors

Series capacitors are sometimes used on transmission and distribution lines to compensate for the inductive reactance drop or to improve the system stability by increasing the amount of power that can be transmitted on tie lines. They are represented by a negative reactance of the form $0 - jX$, in series with the line impedance.

For capacitors specified in microfarads per phase, the reactance may be expressed in the general form:

$$X = \frac{10^6}{2\pi fC} = \Omega/(\text{per phase}) \quad (4-26)$$

When specified in kvars per phase (Q_C), the capacitor voltage rating (V_C) must also be known to calculate the following:

$$X = \frac{V_C^2}{Q_C} \times 10^3 = \Omega/(\text{per phase}) \quad (4-27)$$

It should be noted that the series capacitor voltage rating is a function of the amount of compensation of the design and will generally be a fraction of the system line-to-neutral voltage. The application of series capacitors should always be accompanied by thorough studies, because they can contribute to destructive overvoltage and ferroresonance conditions.

4.7.6 Transformers

4.7.6.1 Two-circuit transformers

The equivalent circuit of a transformer is shown in Figure 4-10(a). The dashed rectangle represents an ideal voltage transformation ratio $n_s/n_p = N$, where n_s and n_p are the number of turns of the secondary, and primary windings, respectively. R_p and R_s are the effective resistances of the windings; X_p and X_s are the leakage reactances. G_0 , the shunt conductance, models the iron losses that remain constant when the transformer is energized at rated voltage and B_M , the shunt inductive susceptance, is equivalent to the quadrature magnetizing current at no load.

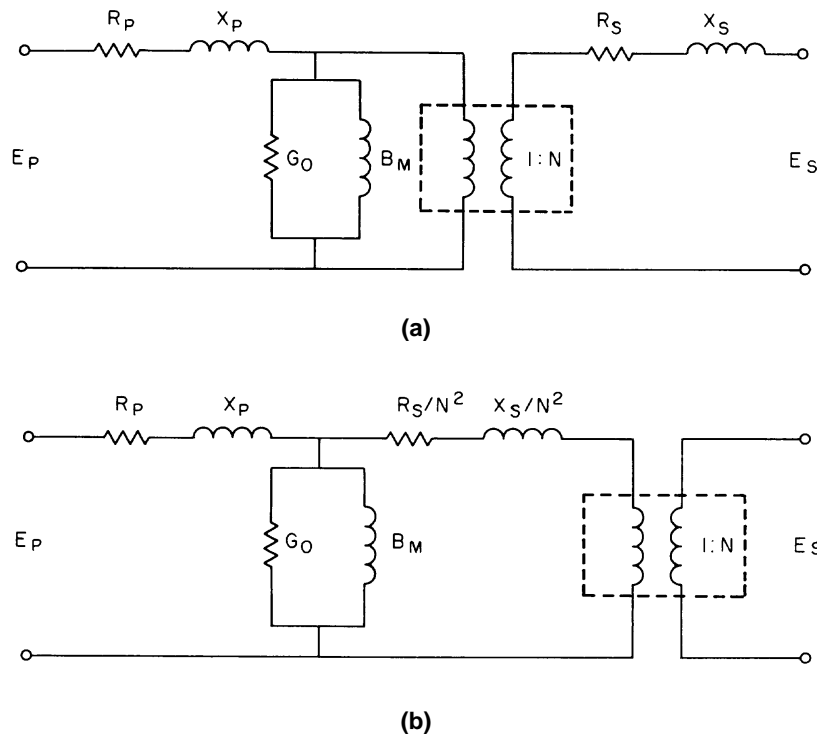

Figure 4-10—Two-winding transformer equivalent circuits

It can be demonstrated that Figure 4-10 (a) is equivalent to Figure 4-10 (b). In the latter, the secondary resistance and reactance have been *reflected* to the primary side of the ideal transformer by multiplication with the inverse of the square of the turns ratio N . This circuit can be approximated by moving the shunt branch and combining the primary and secondary impedances as shown on Figure 4-11 (a). The model can be further simplified by eliminating the shunt branch completely as shown in Figure 4-11 (b). In many types of studies, the resistance R_T , being small with respect to X_T , is also neglected thus reducing the model of the transformer to a single series reactance.

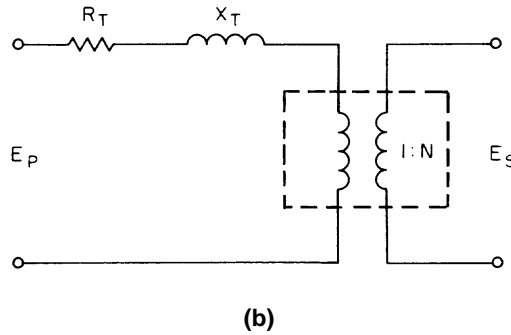
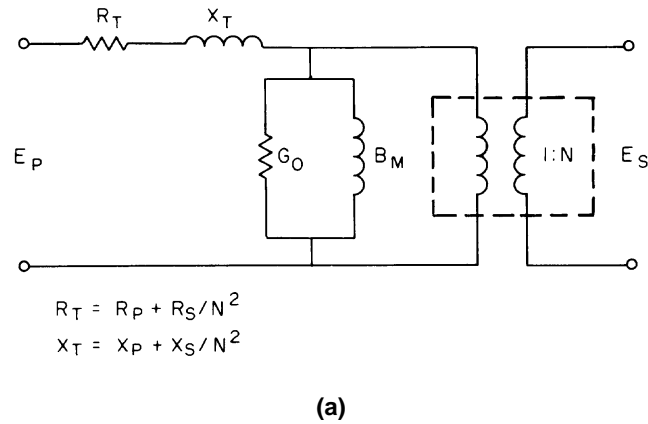

Figure 4-11—Two-winding transformer approximate equivalent circuits

For existing equipment, the nameplate specifies an impedance Z_T and the transformation ratio. An assumption may be made that $X_T \cong Z_T$ so that the single series reactance model may be used.

Use of Figure 4-11 (b) model requires that an estimate of R be made from typical data (IEEE Std C37.010-1979²), and a value for X_T calculated from

$$X = \sqrt{Z^2 - R^2}$$

Transformer test data will usually be sufficient to allow calculation of all the parameters for the circuits of Figure 4-10 (a), Figure 4-11 (a), and Figure 4-11 (b). When maximum accuracy is needed, the effective resistance R_T should include the winding resistances corrected for the operating temperature and another series resistance to account for stray losses (see McFarland and Van Nostrand [B19] and Puchstein and Lloyd [B20]). The model of Figure 4-10 necessitates the creation of a fictitious bus for entry of the shunt admittance data in the program.

²Information on references can be found in 4.10.

4.7.6.2 Transformer taps

Thus far, only single ratio transformers have been considered. In real life, transformers have taps, normally on the high-voltage windings, to provide a voltage ratio best suited to the power system. The taps may be changeable automatically under load (LTC transformer) or fixed (manually changed when de-energized).

The resistances and leakage reactances of the tapped windings are slightly different at different taps. This may be ignored if the correct values are not known. On the other hand, transformer test data may specify impedance values for the taps, in which case these values should be used. The main effect of changing taps is the change of voltage ratio and therefore the change of voltage base for which the impedance diagram should be prepared. This will be described in more detail in 4.8.

The analyst should pay particular attention to the specific requirements of programs for specifying taps. For instance, the tap value 1.05 per unit (105%), interpreted as an additional 5% to the voltage ratio, yields opposite results if applied to the opposite side of the transformer.

Once the data is entered for a given condition and a certain voltage on a specified bus is required, the computer program will, upon request, automatically adjust the taps and modify the system impedances as necessary for the new turns ratio.

4.7.6.3 Three-circuit transformers

In general, three-circuit transformers require models that have three ports or connections to the power system, instead of two. A three-port model is a necessity if each transformer circuit is attached to a different power system circuit. However, for hand calculations and most computer programs, the only model available is the two-port model of Figure 4-11 (b). The goal then is to construct a model that predicts the relevant behavior of the three-winding transformer from the available (and manageable for hand calculations) two-port models.

Test data for three-circuit transformers include short- and open-circuit tests. Open-circuit tests are made by opening all the circuits and applying a voltage to one of the circuits. Though it is possible to consider these magnetizing effects in a model of the transformer, the usual practice is to ignore them. Exceptions to this practice involve zero sequence models for certain types of transformers and specialized studies that involve phenomena for which the magnetizing effect is important. For the purposes of this development, magnetizing effects will be ignored.

Short-circuit tests involve shorting one circuit of a transformer and applying a voltage to another circuit sufficient to give rated current in the circuit pair. The third circuit is usually, but not always, open. Measurements taken in these tests allow a short-circuit test impedance to be calculated for each circuit pair. In the subsequent discussion, we will assume that such a test impedance is available for each pair and that the test is made with the third circuit open. Using notation that corresponds to the winding labeling of IEEE Std C57.12.80-1978, these three values of test impedances may be labeled Z_{HX} , Z_{HY} , and Z_{XY} . A positive sequence test

for Z_{HX} is shown schematically in Figure 4-12 (a). The dashed box surrounding the circuit can be thought of as the transformer enclosure.

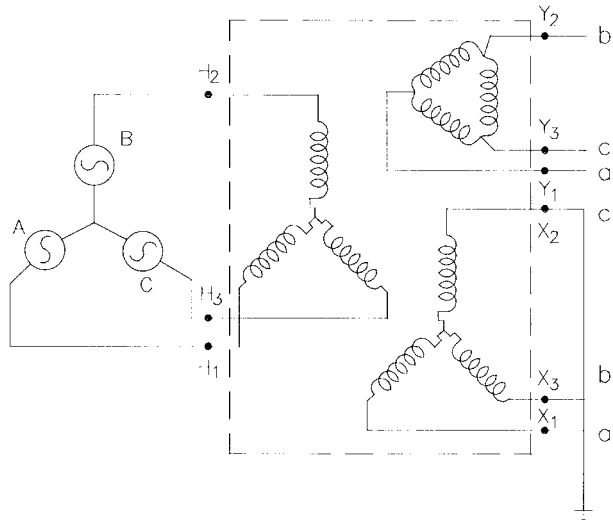

(a) Schematic of a positive sequence test

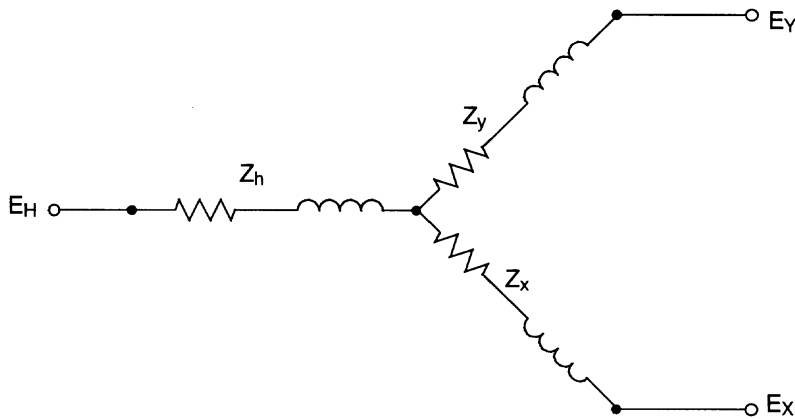

(b) Simplified wye model

Figure 4-12—Three-circuit transformer and approximate equivalent circuits

Though any three-port network made up of at least three independent two-port branch models will suffice, the smallest number of elements with the required three degrees of freedom is three. The two possible connections of these elements are shown in Figure 4-12 (b) and Figure 4-12 (c). Note that the ideal transformer of Figure 4-11 (b) has been omitted.

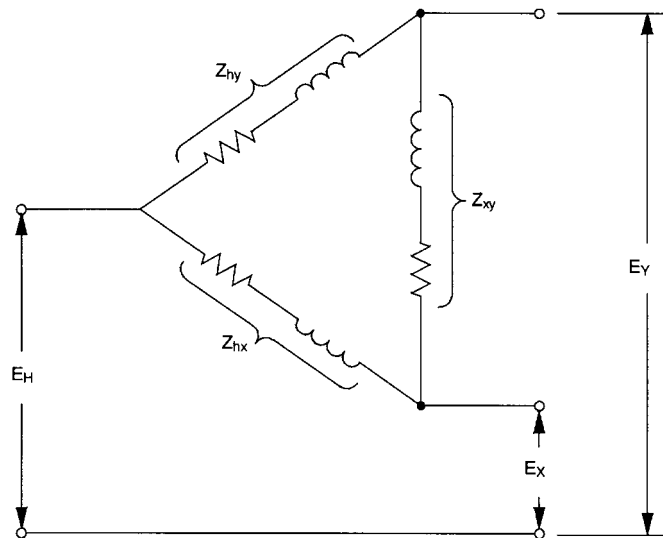

(c) Simplified delta model

Figure 4-12—Three-circuit transformer and approximate equivalent circuits (Continued)

Elimination of the ideal transformer is made possible by calling the voltages at the terminal nodes 1.0 per unit and assigning base voltages of E_H , E_X , and E_Y . The usual choice is the tee model of Figure 4-12 (b). One of the advantages of the tee model is that the relationship between the test impedances and the model parameters is linear and may be easily derived.

By keeping one winding of the model open, shorting another, and applying a voltage to the third, the relationship between the test values and the model parameters is easily shown to be

$$Z_{HX} = Z_h + Z_x \quad (4-28)$$

$$Z_{HY} = Z_h + Z_y \quad (4-29)$$

$$Z_{XY} = Z_x + Z_y \quad (4-30)$$

Be sure that the test values are on the same kVA base. Frequently, test values are given on the winding kVA base. Because the test values are usually known but the model parameters are not, the inverse of these equations is desired. In per unit, they are

$$Z_h = \frac{1}{2}(Z_{HX} + Z_{HY} - Z_{XY}) \quad (4-31)$$

$$Z_x = \frac{1}{2}(Z_{HZ} + Z_{HY} - Z_{HY}) \quad (4-32)$$

$$Z_y = \frac{1}{2}(Z_{HX} + Z_{HY} - Z_{HY}) \quad (4-33)$$

Note that any of these impedances, including the resistive part, may be negative. Occasionally, it is desirable to use the delta model of Figure 4-12 (c). While the model parameters may be derived directly from the test values, this calculation involves the solution of nonlinear equations.

It is easier to derive the tee model and then use a standard wye-to-delta conversion to find the delta model parameters. The equations necessary for this are as follows:

$$Z_{hx} = \frac{Z_h Z_x + Z_x Z_y + Z_y Z_h}{Z_y} \quad (4-34)$$

$$Z_{hy} = \frac{Z_h Z_x + Z_x Z_y + Z_y Z_h}{Z_x} \quad (4-35)$$

$$Z_{xy} = \frac{Z_h Z_x + Z_x Z_y + Z_y Z_h}{Z_h} \quad (4-36)$$

It should be carefully noted that the test and the model parameters are not the same: Z_{HX} is not equal to Z_{hx} , etc.

4.7.6.4 Phase-shifting transformers

Consider again the example in 4.4. Assume this time that the voltage at bus B has the same magnitude but that the angle is shifted back another 2° by the winding arrangement within the transformer, and that the rest of the information given in Figure 4-5 is the same as before. The new impedance diagram will appear as shown in Figure 4-13 (a). Now solve as before with $V_B = 13.60^\circ \angle -1.6^\circ - 2.0^\circ$. The results are shown in Figure 4-13 (b). Note that the phase shift of a mere 2° has caused the real power from A to B to jump from 5 314 to 11 803 kW, but the reactive power decreased from 2 481 to 1 605 kvar.

This example illustrates that the main purpose of phase-shifting transformers to control the flow of real power between two buses.

These transformers usually have load tap changing mechanisms that can vary the phase angle between primary and secondary, either automatically or manually. Thus, computer programs are set up to vary the amount of angle shift (plus or minus), within limits specified in the input, to achieve the desired amount and direction of real power flow.

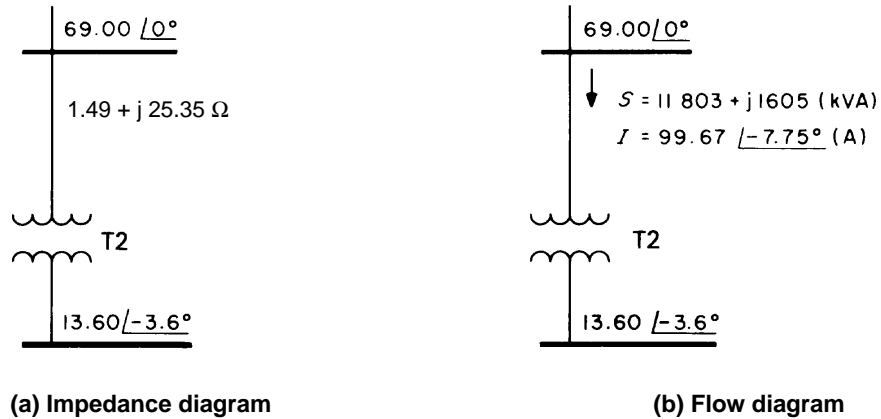

Figure 4-13—Impedance and flow diagrams

The data required by computer programs will generally include the following:

- Center (0° shift) position impedance
- Positive limit position impedance
- Negative limit position impedance
- Angle shift interval between taps
- Number of taps

Program subroutines allow the computer to automatically estimate the values of the impedances at the intermediate taps.

4.7.6.5 Other transformer models

The foregoing discussion has been intended to give the reader an introduction to the subject of transformer modeling. It is far from being complete. The *Electrical Transmission and Distribution Reference Book* [B5] contains a considerable number of models that may be useful.

4.8 Power system data development

4.8.1 Per-unit representations

In power system calculations, variables are routinely expressed using the per-unit system instead of actual quantities such as ohms, volts, etc. While both representations will yield identical results, the per-unit method is generally preferred for hand calculations because it will do the job much more conveniently, especially if the system being studied has several different voltage levels. Also, the impedances of electric apparatus are usually given in per unit or percent by manufacturers.

The per-unit value of any quantity is its ratio to the chosen base quantity of the same dimensions, expressed as a dimensionless number. For example, if base voltage is taken to be 4.16 kV, voltages of 3 740 V, 4 160 V, and 4 330 V will be 0.9, 1.00, and 1.04, respectively, when expressed in per unit on the given base voltage. The chosen base voltage, 4.16 kV, is referred to as base voltage, 100% voltage, or unit voltage.

There are four base quantities in the per-unit system: base kVA, base volts, base ohms, and base amperes. They are so related that the selection of any two of them determines the base values of the remaining two. It is a common practice to assign study base values to kVA and voltage. Base amperes and base ohms are then derived for each of the voltage levels in the system.

In power system studies, the base voltage is usually selected as the nominal system voltage at one point of the system, such as the voltage rating of a generator or the nominal voltage at the delivery point of the utility supply. The base kVA can be similarly taken as the kVA rating of one of the predominant pieces of system equipment, such as a generator or a transformer; but usual practice is to choose a convenient round number such as 10 000 for the base kVA. The latter selection has some advantage of commonality when several studies are made, while the former choice means that at least one significant component will not have to be converted to a new base.

The basic relationships for the electrical per unit quantities are as follows:

$$\text{per-unit volts} = \frac{\text{actual volts}}{\text{base volts}} \quad (4-37)$$

$$\text{per-unit amperes} = \frac{\text{actual amperes}}{\text{base amperes}} \quad (4-38)$$

$$\text{per-unit ohms} = \frac{\text{actual ohms}}{\text{base ohms}} \quad (4-39)$$

For three-phase systems, the nominal line-to-line system voltages are normally used as the base voltages. The base kVA is assigned the three-phase kVA value. The derived values of the remaining two quantities are as follows:

$$\text{base amperes} = \frac{\text{base kVA}}{\sqrt{3} \text{ base kV}} \quad (4-40)$$

$$\text{base ohms} = \frac{(\text{base kV})^2}{\text{base MVA}} \quad (4-41)$$

It is convenient in practice to convert directly from ohms to per-unit ohms without first determining base ohms according to the following expression:

$$\text{per-unit ohms} = \frac{\text{ohms} \times \text{base MVA}}{(\text{base kV})^2} \quad (4-42)$$

For a three-phase system, the impedance is in ohms per phase, the base kVA is the three-phase value, and the base kV is line-to-line.

Where two or more systems with different voltage levels are interconnected through transformers, the kVA base is common for all systems; but the base voltage of each system is determined by the turns ratio of the transformer connecting the systems, starting from the one point for which the base voltage has been declared. Base ohms and base amperes will thus be correspondingly different for systems of different voltage levels.

Once the system quantities are expressed as per-unit values, the various systems with different voltage levels can be treated as a single system during the solution for the unknown variables. Ideal transformers are typically eliminated from the circuit model by a prudent choice of voltage bases. Only when reconvertng the per-unit values to actual voltage and current values is it necessary to recall that different base voltages exist throughout the system.

When impedance values of devices are expressed in terms of their own kVA and voltage ratings, which differ from the base values of a circuit, it is necessary to refer these values to the system base values. This typically happens due to equipment kVA bases being different from the chosen system kVA base. In such cases, the per-unit impedance of the device must be changed to either a new base kVA or new base voltage, or both, by the following equation:

$$\text{per-unit } Z_2 = \text{per-unit } Z_1 \times \frac{(\text{base kV}_1)^2}{(\text{base kV}_2)^2} \frac{\text{base kVA}_2}{\text{base kVA}_1} \quad (4-43)$$

where subscripts 1 and 2 refer to the equipment and system base conditions, respectively.

4.8.2 Applications example

A section of the power system shown in Figure 1-1 of Chapter 1 has been repeated in Figure 4-14 to illustrate the per-unit system.

The steps in reducing the data to per unit are as follows:

- a) Select base power: $S = 10\,000$ kVA
- b) Determine base voltages
 - 1) Select bus 02:69-2 nominal voltage of 69 kV as base kV at this bus
 - 2) Calculate base voltages at other system levels

$$\text{Bus 04:MILL-2: kV}_{\text{base}} = 69.0 \times \frac{13.8}{69} = 13.8 \text{ kV}$$

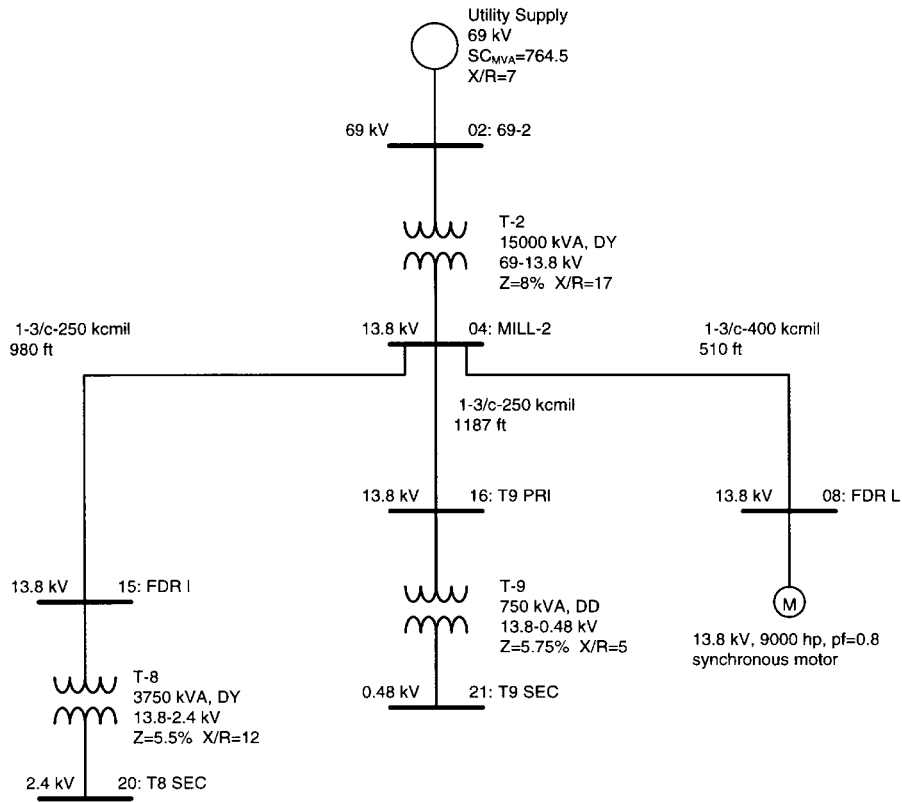

Figure 4-14—Single-line diagram for example application of per-unit system

$$\text{Bus 21:T9 SEC: } kV_{\text{base}} = 13.8 \times \frac{0.48}{13.8} = 0.48 \text{ kV}$$

$$\text{Bus 20:T8 SEC: } kV_{\text{base}} = 13.8 \times \frac{2.4}{13.8} = 2.4 \text{ kV}$$

c) Calculate base impedances using Equation (4-41)

1) 69 kV system:

$$Z_{\text{base}} = \frac{69^2 \times 10^3}{10\,000} = 476.1 \, \Omega$$

2) 13.8 kV system:

$$Z_{\text{base}} = \frac{13.8^2 \times 10^3}{10\,000} = 19.044 \, \Omega$$

- 3) 2.4 kV system:

$$Z_{\text{base}} = \frac{2.4^2 \times 10^3}{10\,000} = 0.576 \, \Omega$$

- 4) 0.48 kV system:

$$Z_{\text{base}} = \frac{0.48^2 \times 10^3}{10\,000} = 0.023 \, \Omega$$

- d) Calculate base currents using Equation (4-40)

- 1) 69 kV system:

$$I_{\text{base}} = \frac{10\,000}{\sqrt{3} \times 69.0} = 83.67 \, \text{A}$$

- 2) 13.8 kV system:

$$I_{\text{base}} = \frac{10\,000}{\sqrt{3} \times 13.8} = 418.37 \, \text{A}$$

- 3) 2.4 kV system:

$$I_{\text{base}} = \frac{10\,000}{\sqrt{3} \times 2.4} = 2405.63 \, \text{A}$$

- 4) 0.48 kV system:

$$I_{\text{base}} = \frac{10\,000}{\sqrt{3} \times 0.48} = 12028.13 \, \text{A}$$

- e) Summarize the base data in Table 4-6.
f) Convert transformer impedances to the new base using Equation (4-43).

- 1) T-2:

$$Z = \frac{0.4698 + j7.9862}{100} \times \frac{69^2}{69^2} \times \frac{10}{15} = 0.0031 + j0.0532 \text{ per unit}$$

Table 4-6—Summary of base values for example system

Bus(es)	Base values			
	Power (kVA)	Voltage (kV)	Impedance (Ω)	Current (A)
02:69-2	10 000	69.0	476.10	83.67
04:MILL-2, 08:FDR L, 16:T9 PRI, 15:FDR I	10 000	13.8	19.044	418.37
21:T9 SEC	10 000	0.48	0.023	12 028.13
20:T8 SEC	10 000	2.4	0.576	2 405.63

or

$$Z = \frac{0.4698 + j7.9862}{100} \times \frac{13.8^2}{13.8^2} \times \frac{10}{15} = 0.0031 + j0.0532 \text{ per unit}$$

2) T-8:

$$Z = \frac{0.4568 + j5.481}{100} \times \frac{13.8^2}{13.8^2} \times \frac{10}{3.75} = 0.0122 + j0.1462 \text{ per unit}$$

or

$$Z = \frac{0.4568 + j5.481}{100} \times \frac{2.4^2}{2.4^2} \times \frac{10}{3.75} = 0.0122 + j0.1462 \text{ per unit}$$

3) T-9:

$$Z = \frac{1.1277 + j5.6383}{100} \times \frac{13.8^2}{13.8^2} \times \frac{10}{0.75} = 0.1504 + j0.7518 \text{ per unit}$$

or

$$Z = \frac{1.1277 + j5.6383}{100} \times \frac{0.48^2}{0.48^2} \times \frac{10}{0.75} = 0.1504 + j0.7518 \text{ per unit}$$

g) Calculate line impedance in ohms

The cables in the example system are 3/C, copper cables, paper insulated, shielded conductors with the data given in Table 4-7. Shunt capacitive reactance is neglected due to the relatively short lengths of the cables.

Table 4-7—Cable data for example system

Length (ft)	Cable number	Bus		R ($\Omega/1\ 000\ \text{ft}$)	X_L ($\Omega/1\ 000\ \text{ft}$)	X_C ($\Omega/1\ 000\ \text{ft}$)
		From	To			
510	1	04:MILL-2	08:FDR L	0.0284	0.0344	neglect
1187	2	04:MILL-2	16:T9 PRI	0.0441	0.0367	neglect
980	3	04:MILL-2	15:FDR I	0.0441	0.0367	neglect

- 1) Cable #1:

$$R = 0.0284 \times \frac{510}{1000} = 0.0145\ \Omega$$

$$X_L = 0.0344 \times \frac{510}{1000} = 0.0175\ \Omega$$

- 2) Cable #2:

$$R = 0.0441 \times \frac{1187}{1000} = 0.0523\ \Omega$$

$$X_L = 0.0367 \times \frac{1187}{1000} = 0.0436\ \Omega$$

- 3) Cable #3:

$$R = 0.0441 \times \frac{980}{1000} = 0.0432\ \Omega$$

$$X_L = 0.0367 \times \frac{980}{1000} = 0.036\ \Omega$$

- h) Calculate line/cable impedances in per unit with Equation (4-42)

- 1) Cable #1:

$$Z = \frac{0.0445 + j0.0175}{19.044} = 0.00076 + j0.00092\ \text{per unit}$$

2) Cable #2:

$$Z = \frac{0.0523 + j0.0436}{19.044} = 0.00275 + j0.00229 \text{ per unit}$$

3) Cable #3:

$$Z = \frac{0.0432 + j0.036}{19.044} = 0.00227 + j0.00189 \text{ per unit}$$

i) Calculate X'_d of the synchronous machine in per unit with Equation (4-43)

1) Synchronous motor on bus 08:FDR L:

$$X'_d = j0.2 \times \frac{13.8^2}{13.8^2} \times \frac{10\,000}{9\,000/0.8} = j0.1778 \text{ per unit}$$

j) Calculate the utility system impedance in per unit

1) at bus 02: 69-2:

$$Z = (0.876 + j6.1655) \times \frac{10}{69^2} = 0.0018 + j0.013 \text{ per unit}$$

The per-unit data and the base voltages have been transferred to the impedance diagram of Figure 4-15 in readiness for the preparation of computer input document and as a record of the basic information for the study. The previous calculation method illustrates the use of the per-unit system by selection of base voltages on the different parts of the system using transformer turns ratios. While this method is straightforward for hand calculations, it can lead to errors in interpretation of results when used in computer studies where nominal voltages in different parts of the systems are not related by the transformer turns ratios. In computer studies, it is usually preferred to select the base voltages for each part of the system to be equal to the nominal voltage without specific regard for transformer turns ratios. Any difference between the transformer turns ratio and the ratio of the bases selected for the buses on each side of the transformer is accounted for by using an off-nominal (not equal to 1.0) turns ratio in the computer program model of the transformer. It is customary to represent the off-nominal ratio as $N:1$, where N is associated with the high-voltage winding. This approach to selecting base voltages allows transformer taps to be incorporated without recalculating the entire set of base values at each affected voltage level.

The use of nominal voltages as base voltages has the following advantages:

- The chance of errors in interpretation of results is reduced; it is clear to all what 1.0 per unit means.

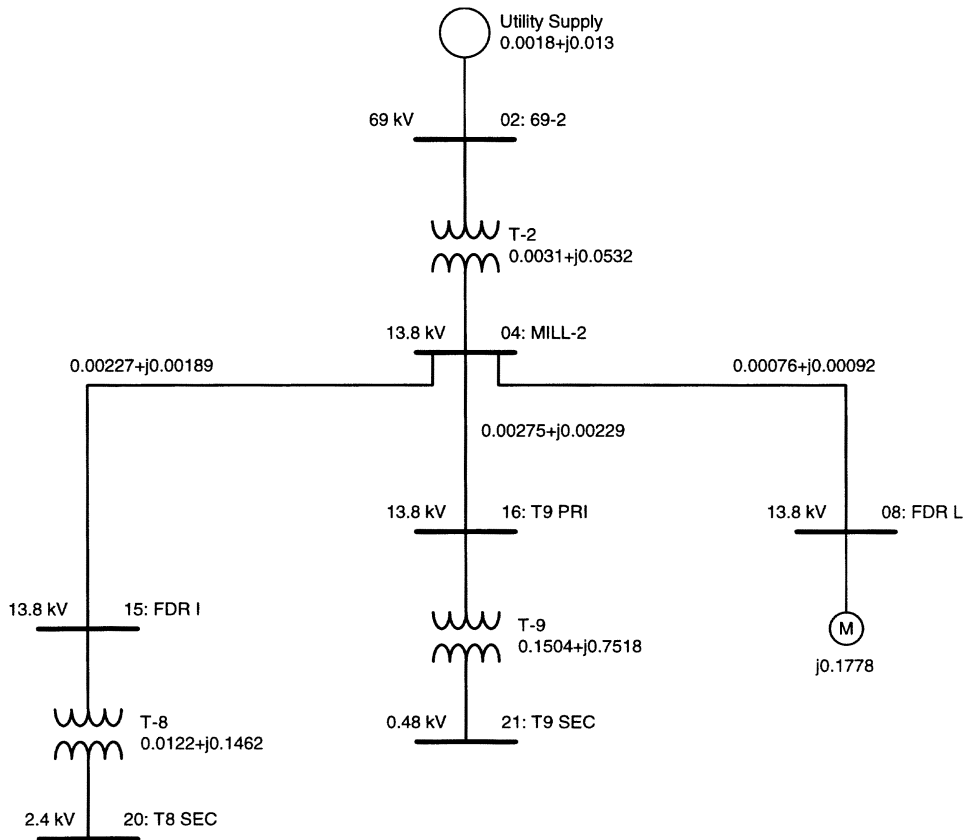

Figure 4-15—Impedance diagram showing results of per-unit conversions

- It is much easier to spot abnormally high or low voltages. One only has to scan for voltages outside a certain range, say 0.95 to 1.05 per unit.
- Changes in network configuration will not require changes in network impedances.

For example, if two parts of the 13.8 kV system are modeled using base voltages of 14.427 and 14.0 kV due to different transformer turns ratios, the study of the outage of one transformer and the connection of the two systems via a normally open breaker could not be performed until the impedances of one of the systems was converted to the base of the other.

The user's manual of most computer programs will contain program-specific information on the modeling of transformer taps and off-nominal ratios.

4.9 Models of bus elements

4.9.1 Loads in general

Power system loads may be classified by one or a combination of the following types, to account for their voltage dependence:

- Constant power S
- Constant impedance Z
- Constant current I

Figure 4-16 shows their respective power/voltage relationships.

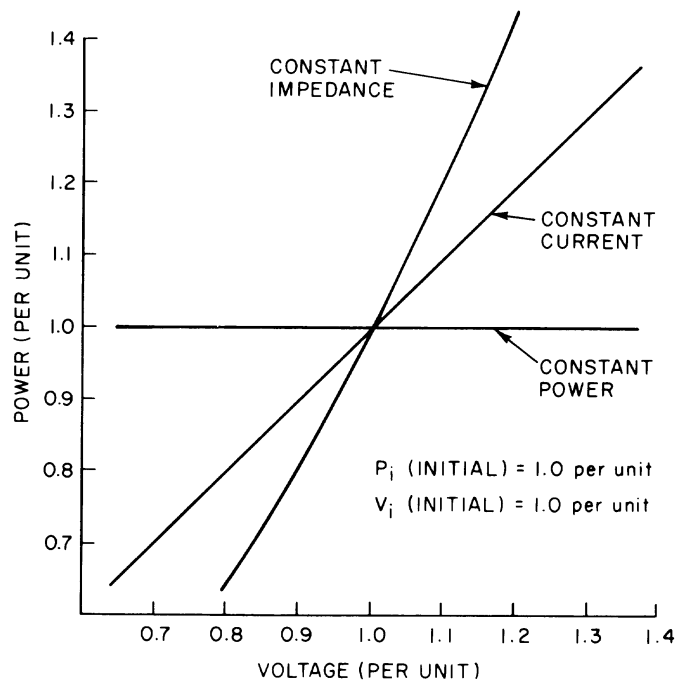

Figure 4-16—Effect of voltage variations for three types of loads

A single expression,

$$\left(\frac{S}{S_i}\right) = \left(\frac{V}{V_i}\right)^k, \quad (4-44)$$

can represent the three load types by making $k = 0$ for constant power, $k = 1$ for constant current, and $k = 2$ for constant impedance loads. S_i is the initial power at V_i , the initial voltage; S is the power at voltage V .

A more general expression can be formulated by expanding Equation (4-44) for the real and reactive power:

$$P + jQ = P_i \left(\frac{V}{V_i} \right)^{k_1} + jQ_i \left(\frac{V}{V_i} \right)^{k_2} \quad (4-45)$$

The subscript i has the same meaning as in Equation (4-44). The exponents k_1 and k_2 could be different and nonintegers.

A load or group of loads could also be expressed in a more restrictive way by

$$P + jQ = \left[A + B \frac{V}{V_i} + C \left(\frac{V}{V_i} \right)^2 \right] P_i + j \left[D + E \frac{V}{V_i} + F \left(\frac{V}{V_i} \right)^2 \right] Q_i \quad (4-46)$$

again to reflect voltage dependency. In this case A , B , C and D , E , F represent fractions of P and Q , respectively. The sums $A + B + C$ and $D + E + F$ must equal 1.

In stability studies, frequency, like voltage, may become an important factor in the modeling of loads. Linear frequency dependence would take the following form:

$$P + jQ = (1 + G\Delta f)P_i + j(1 + H\Delta f)Q_i \quad (4-47)$$

where G and H are the fractions of P_i and Q_i , respectively, being affected by the frequency deviation from the steady-state frequency.

The problem of assigning correct values to the constants (k_1 , k_2 , A through H) is very difficult when studying utility type systems because the nature of the load is not known accurately. Additionally, the tasks of simulating the load in all its details would require a computer program of such size and cost that the effort might be prohibitive (see Adler and Mosher [B1], IEEE Committee Report [B14], Ilicito, Ceyhan, and Ruckstuhl [B15], and Kent et al. [B17]).

Industrial and commercial power systems are relatively modest in size. Moreover, bus loads are often arranged in such a way that grouping by type is easy to do, thus facilitating the preparation of computer input data and offering the possibility of combining large sections of the system to reduce the overall sizes of the study sections.

4.9.2 Induction motors

The induction motor equivalent circuit is shown in Figure 4-17 (see Fitzgerald, Kingsley, Jr., and Umson [B6], McFarland and Van Nostrand [B19], and Puchstein and Lloyd [B20]). The solution of this circuit for values of slip s at a given input voltage and frequency will yield, among other performance characteristics, three sets of curves: torque, current, and power factor, typified in Figure 4-18, Figure 4-19, and Figure 4-20.

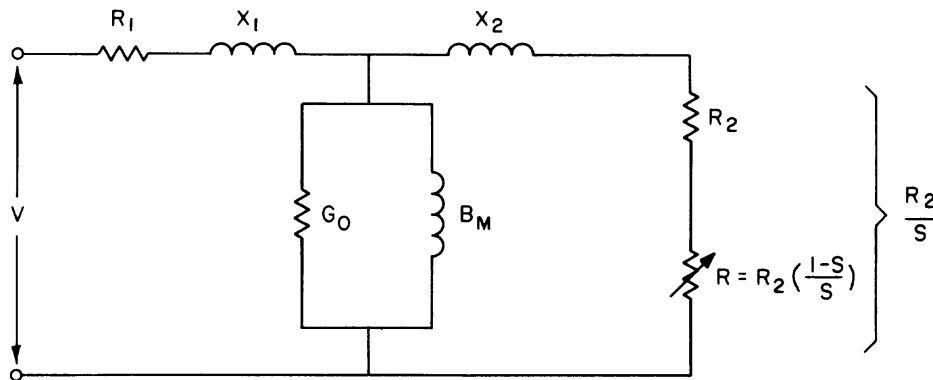

Figure 4-17—Induction motor equivalent circuit

If the three curves are known, the shaft output power can be calculated for any speed using the slip and torque with the following equation:

$$\tau = 7.05 \times \frac{P_o}{(1-s)N_s} \quad (4-48)$$

where

- τ is the torque in lb-ft
- P_o is the output power in watts
- N_s is the synchronous speed in rev/min

Input power can also be calculated using the current and power factor curves for the desired voltage.

$$S = 3VI(\cos\theta + j\sin\theta) \quad (4-49)$$

$$\theta = \arccos \text{PF} \quad (4-50)$$

where

- V is the line-to-neutral voltage

In some cases, the equivalent circuit constants will be known along with the input or output power. The analytical solution, then, consists of finding the correct value of slip that will match the specified power. A cut-and-try method may be used here; but this would prove to be a tedious process if solved by hand because of the repeated reduction of the complex network for each trial of slip value. Computers excel at iterative methods, and for this reason

programs will generally be written to accept this kind of input. The *equivalent circuit* model finds its major applications in motor starting and stability studies.

The curves of Figures 4-18 through 4-20 are also used in motor-starting studies. The computer input data will consist of the motor equivalent circuit and/or sets of values of torque, current, and power factor taken at different intervals of slip along these curves. The program will normally require a similar torque-speed curve for the load. The motor and load moments of inertia will complement the description of the mechanical system.

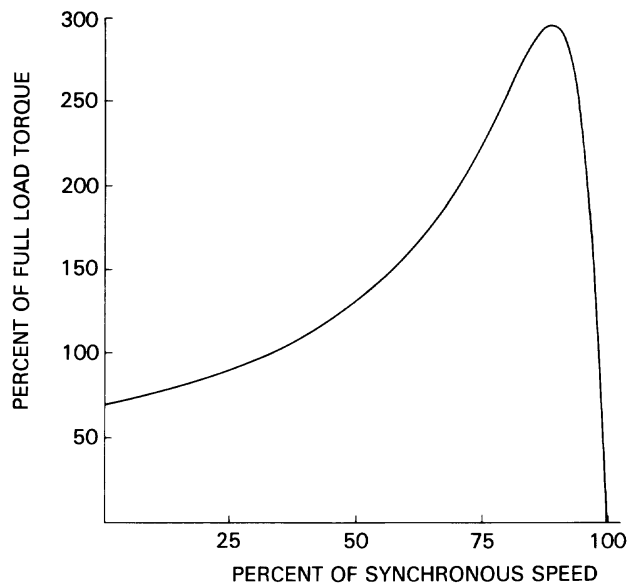

Figure 4-18—Induction motor torque versus speed

NOTE—All inertias must be calculated on the same base. In addition, inertias of couplings, pulleys, and flywheels should also be considered.

The equivalent circuit constants can be calculated from motor test data or obtained from the manufacturer (calculated or test values). IEEE Std 112-1996, McFarland and Van Nostrand [B19], and Puchstein and Lloyd [B20] describe the methods used for the calculations from test data.

4.9.2.1 Constant load model

It may be appropriate in some studies to represent a motor as a constant kVA load:

$$S = P + jQ$$

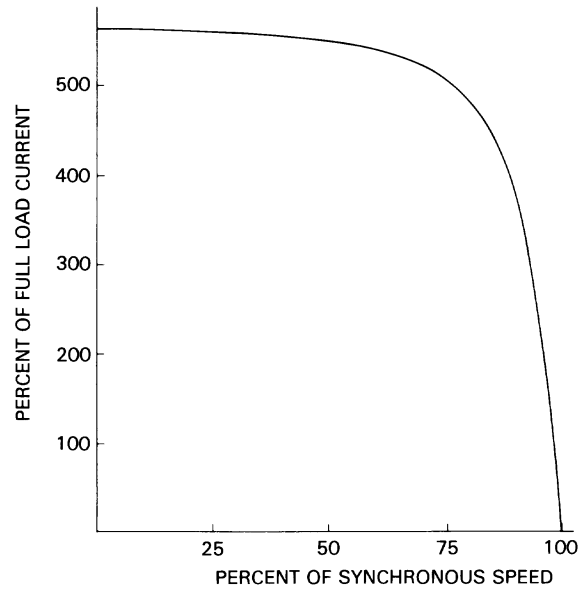

Figure 4-19—Induction motor current versus speed

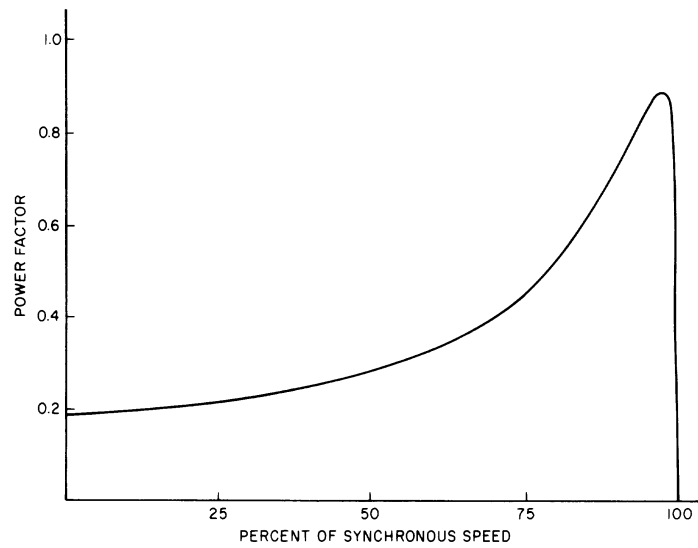

Figure 4-20—Induction motor power factor versus speed

where P and Q are constant. This requires that the shaft horsepower (BHP), nameplate voltage, motor efficiency η , and power factor be known or estimated and substituted in the following equations:

$$P(\text{kW}) = 0.746 \times \frac{\text{BHP}}{\eta} \quad (4-51)$$

$$\theta = \arccos \text{PF} \quad (4-52)$$

$$Q(\text{kvar}) = P \tan \theta \quad (4-53)$$

Both the efficiency and power factor are functions of motor voltage and percent load. An example is shown in Figure 4-21. Consequently, if the objectives of the study warrant, it may be necessary to estimate the voltage in order to determine appropriate values for τ and PF. Manufacturers publish motor characteristics (current, efficiency, power factor) at various loadings for a wide spectrum of motor sizes and types. This model is generally applicable in load flow studies or other studies in which the effect of model simplification is of secondary importance. It should be emphasized that the reactive power, Q , is positive for an induction motor, even if the motor is operating in the generating mode, that is, with a negative slip.

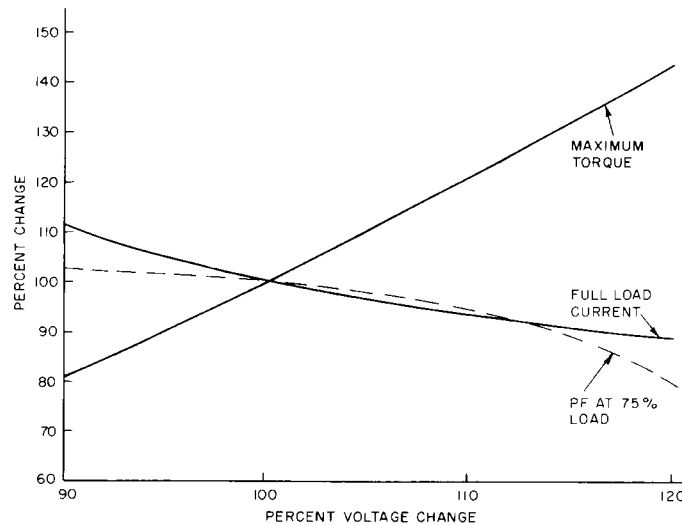

Figure 4-21—Effect of voltage variations on typical induction motor characteristics

4.9.2.2 Models for short-circuit studies

In this area of power system analysis, standards specify the model to be used for motors to account for their contributions to short-circuit currents (see IEEE Std 112-1996 and Huening,

Jr. [B7]). The model for a motor is invariably a voltage source in series with an impedance as in Figure 4-22.

The voltage source is justified by the fact that at the very instant of a short-circuit, the flux that exists at the air gap cannot change instantly. The energy that this flux represents has to dissipate in the form of current through resistance. This current flows in the electrical circuits linked by that flux, and is limited by the inductance of these circuits. The stator winding, being linked by that flux and having inductance, will therefore act as a limited source of current to the network to which it is connected. The flux will decay rapidly because there is no source of current to maintain it. Thus, the time constant will be in the order of a few cycles.

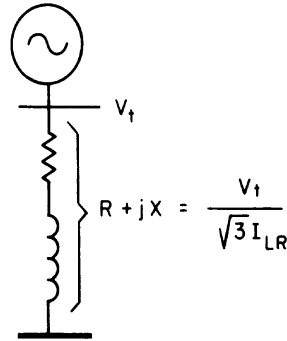

Figure 4-22—Model of induction motor for short-circuit study

The value of impedance in series with the voltage source is nearly the same as that of the impedance which limits the locked rotor current when voltage is applied to the motor at rest. Accordingly, the impedance in Figure 4-22 can be calculated from the following:

$$R + jX = \frac{V}{\sqrt{3}I_{LR}} \quad (4-54)$$

where

- V is the motor nameplate line-to-line voltage and
- I_{LR} is the motor locked rotor current

The resistance R is usually small relative to the reactance X . Moreover, short-circuit currents have low power factors. These two factors justify neglecting R in those short-circuit studies where only the symmetrical current magnitude is required.

When the short-circuit study objective is to check circuit breaker capabilities, it is necessary to consider different conditions such as first cycle duty, momentary duty, interrupting duty, and breaker speed, in order to determine an appropriate value of motor series impedance that

will account for the decay in the current that it contributes to a fault. This is spelled out in IEEE Std C37.010-1979 and takes the form of impedance multiplying factors that vary as a function of time from the moment a fault occurs. The rationale for neglecting small motor contributions is based on their electrical remoteness from the power circuit breakers and their very short time constants.

4.9.2.3 Constant impedance model

It is sometimes desirable to determine the system voltages at the instant a motor at rest is energized. The appropriate model is the equivalent circuit given earlier with the slip s equal to 1, which reduces the circuit to one with a constant impedance. It is generally simplified to a single impedance to ground and calculated from Equation (4-54).

4.9.3 Synchronous machines

Synchronous machine models vary tremendously with the type of study. In this subclause, the text will include both the simpler model for steady-state conditions and the more complicated models for transient conditions.

4.9.3.1 Steady-state models

4.9.3.1.1 Generators

Once a power system has settled down after a change of any kind, generator output voltages will have been automatically brought back to the desired output values by the voltage regulators. The prime mover governor will also have taken a steady position to maintain the generator speed, consistent with the rest of the system, and to supply the amount of power programmed by its setting.

The generator output voltage will be a function of the field current. Its output power will be a function of the mechanical power applied to its shaft, which will also determine the rotor angle that the field poles maintain relative to the revolving magnetic field in the stator.

Thus, in a load flow study for steady-state conditions, the generator can be modeled as a constant voltage source and a scheduled amount of kW. The system operating conditions may demand that a generator voltage output be adjusted automatically so that it supplies an amount of reactive power such that a bus, somewhere on the system, maintains a specified voltage. In this situation, the analyst specifies a range of reactive power (kvar) within which the machine will operate. The generator voltage will be adjusted by the program.

Other possibilities are

- a) To specify a voltage and angle and let the kW and kvar fall where they may.
- b) To specify fixed kW and kvar and let the voltage fall where it may.

The last alternative suggests that a generator may be considered analytically as a negative constant power load. Many computer programs will accept negative power signs. Thus negative kW input to the bus load data would model a generator.

4.9.3.1.2 Synchronous condenser

One difference between this machine and a generator is that the condenser consumes a small amount of real power corresponding to its losses. It will generally be equipped with a voltage regulator similar to a generator and have its reactive power output, specified within certain limits, adjusted by the computer program to maintain a specified voltage at its own terminals or elsewhere in the system.

4.9.3.1.3 Synchronous motors

Synchronous motors may or may not be equipped with regulators to control their excitation. Those equipped with regulators may control voltage, power factor, reactive power, or even current at their terminals or elsewhere. The real power in kW will be a function of the load driven by the motor, and will not be adjustable for the given set of conditions under study.

The analyst may, therefore, resort to modeling the synchronous motors as negative generators with reactive power limits, if a voltage or current control device is supplied. In the case of power factor or reactive power regulators, the specified kW will define a value of kvar using Equations (4-55) through (4-57).

For motors with fixed excitation and a given fixed load, vee-curves are often used to calculate the equivalent reactive power. Another option is to calculate (approximately) the reactive power using given manufacturer's data and detailed formulas. Figure 4-23 shows the vee-curve for a particular motor. The reactive power is calculated as follows:

- a) Draw a vertical line for the fixed excitation current
- b) Read the line current (armature current) I at the intersection of the load line representing the motor running load and the field current line
- c) Estimate the motor terminal voltage (line to line)
- d) Calculate the reactive power

$$\text{kvar} = \sqrt{3(V_{L1}I_1)^2 - \text{kW}_{3\phi}^2} \quad (4-55)$$

Alternately, if the power factor curves are shown on the graph, replace above steps c) and d) with the following:

- a) Read the power factor at the intersection of the load line and I line
- b) Calculate the reactive power

$$\text{kvar} = \text{kW} \tan \theta \quad (4-56)$$

$$\theta = \arccos \text{PF} \quad (4-57)$$

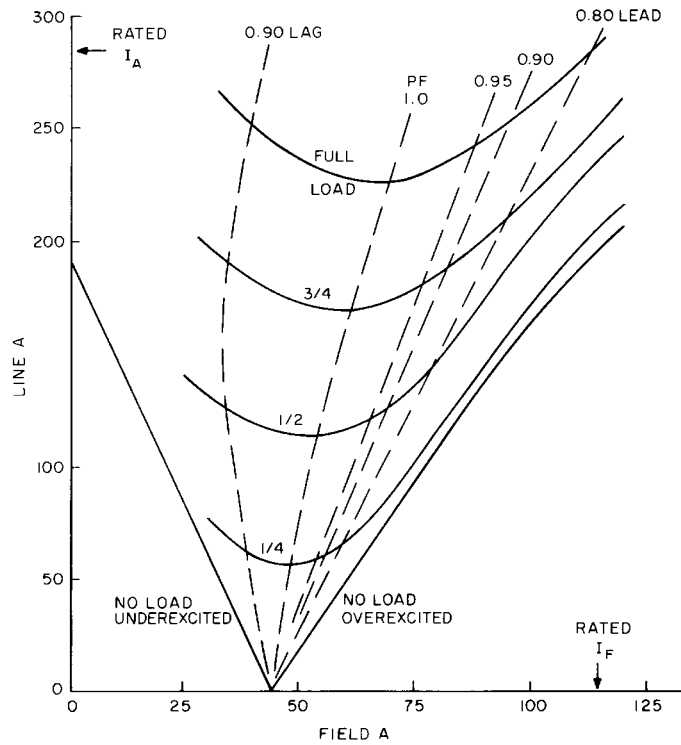

Figure 4-23—Vee-curves: Synchronous motor, 2000 hp, 4000 V, 180 r/min, 0.8 lead power factor

4.9.3.2 Short-circuit models

The current contributed to a fault by a synchronous machine varies with time, from a high initial value to a moderate final steady-state value. Equations (4-58), (4-59), and (4-60) depict this variation of current as a function of time for a three-phase short circuit at the terminals of a machine operating initially unloaded.

$$I_{ac} = E \left[\frac{1}{X_d} + \left(\frac{1}{X'_d} - \frac{1}{X_d} \right) e^{-\frac{t}{T'_d}} + \left(\frac{1}{X''_d} - \frac{1}{X'_d} \right) e^{-\frac{t}{T''_d}} \right] \tag{4-58}$$

$$I_{dc} = \frac{\sqrt{2}E \cos \alpha}{X''_d} e^{-\frac{t}{T'_d}} \tag{4-59}$$

$$I_T = \sqrt{I_{ac}^2 + I_{dc}^2} \tag{4-60}$$

The rms value of the total current I_T is made up of two components:

- a) A power frequency ac component I_{ac} , the rms value of which decreases with time t , in accordance with Equation (4-58). This component is called the symmetrical current.
- b) A dc component I_{dc} , which decreases with time in accordance with Equation (4-59).

The initial magnitude of I_{dc} is a function of the angle α of the voltage wave at which the short circuit occurred. It determines the amount of offset of the current wave and is proportional to the rate of change of voltage at the instant of short circuit. The offset is maximum at $\alpha = 0$ because the rate of change of voltage is maximum when the voltage is 0. The offset is 0 at $\alpha = 90^\circ$ of change is 0 at the positive or negative peak voltage values.

In the above equations,

E is the open circuit voltage

X_d, X'_d, X''_d are the direct-axis synchronous, transient, and subtransient reactances, respectively

T_d, T'_d, T''_d are the armature and the direct-axis transient and subtransient short-circuit time constants, respectively

For typical values of reactances and time constants, and with the maximum offset condition ($\cos \alpha = 1$), the equations will reduce to the following:

At time $t = 0$ (under subtransient conditions)

$$I''_{ac} = \frac{E}{X''_d} \quad (4-61)$$

$$I''_{dc} = \frac{\sqrt{2}E}{X''_d} \quad (4-62)$$

$$I'_T = \frac{E}{X''_d} \sqrt{1+2} = \frac{E}{X''_d} \sqrt{3} \quad (4-63)$$

At time $t = \infty$

$$I_{ac} = \frac{E}{X_d}$$

$$I_{dc} = 0$$

$$I_T = I_{ac} = \frac{E}{X_d} \quad (4-64)$$

Because T'_d is much larger than T''_d , there is a time t' smaller than T'_d and larger than T''_d , that will make e^{-t'/T'_d} approximately equal to 1 and e^{-t'/T''_d} approximately equal to 0. In this case, the original equations reduce to the following:

$$I'_{ac} = \frac{E}{X'_d} \quad (4-65)$$

$$I'_{dc} = \frac{\sqrt{2}Ee^{-t'/T'_a}}{X''_d} \quad (4-66)$$

Should there be an impedance $Z_L = R_L + jX_L$ between the machine terminal (still at no load) and the point of fault, Equations (4-61), (4-64), and (4-65) will become

$$I''_{ac} = \frac{E}{R_L + j(X_L + X''_d)} \quad (4-67)$$

$$I'_{ac} = \frac{E}{R_L + j(X_L + X'_d)} \quad (4-68)$$

$$I_{ac} = \frac{E}{R_L + j(X_L + X_d)} \quad (4-69)$$

The armature time constant T_a will be shortened appreciably by addition of resistance R_L in the external circuit. So Equation (4-66) will become

$$I'_{dc} = \frac{\sqrt{2}Ee^{-t/T'_a}}{X''_{(T'_a < T_a)}} \quad (4-70)$$

The offset current will decay more rapidly the farther away (electrically) the machine is from the point of fault.

The voltage E , in all the above equations, is equal to the terminal voltage V_t , since it was assumed that the machine was carrying no load before the short circuit. If the machine was carrying a current I_L before the short circuit, the voltage E will be different in each equation, to satisfy prefault conditions. For the case of a generator, the voltages in Equations (4-61), (4-64), and (4-65) will be

$$E'' = V_t + I_L X''_d \quad (4-71)$$

$$E' = V_t + I_L X'_d \quad (4-72)$$

$$E = V_t + I_L X_d \quad (4-73)$$

respectively. These voltages have been called voltage behind subtransient reactance (E''), voltage behind transient reactance (E'), and voltage behind synchronous reactance (E). It is not practical, in short-circuit studies, to calculate the system currents for the entire period—from the time of fault to the time that the current reaches a steady-state value. The normal procedure is to solve the network at times $t = 0$ or $t = t'$, or both, using the models of Figure 4-25. Network solutions at $t = \alpha$ are meaningless since the machine field excitation has likely changed by that time.

Depending on the study objectives, the effect of the offset current I_{dc} may or may not be important. In power circuit breaker applications, however, it is a very important consideration. To obviate the difficulties in solving Equation (4-66), the breaker standards specify multipliers for the X''_d and X'_d current components. These are functions of machine type and of the time from the inception of the short circuit. IEEE Std 122-1991 lists those multipliers, gives examples of their use, and expands on this important aspect of short-circuit studies.

The models of Figures 4-24 and 4-25 are also applicable to synchronous motors and synchronous condensers (using motor convention for the Kirchhoff's Voltage Law equations), the difference being that the E'' , E' , and E voltages are calculated with the following:

$$E'' = V_t - I_L X''_d \quad (4-74)$$

$$E' = V_t - I_L X'_d \quad (4-75)$$

$$E = V_t - I_L X_d \quad (4-76)$$

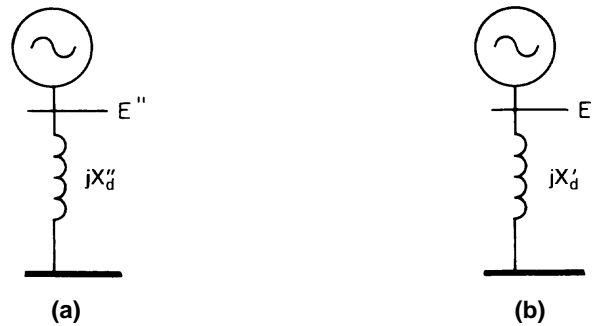

Figure 4-24—Models of synchronous machines for short-circuit studies

4.9.3.3 Stability models

In stability studies, it is necessary to solve the electrical networks at a series of intervals starting from the time of inception of a disturbance and continuing for as long as necessary to

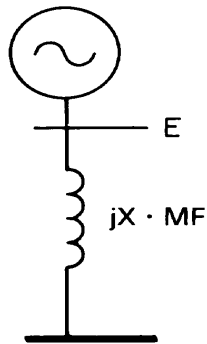

Figure 4-25—General model for ac machines in short-circuit studies

establish a trend in the system performance. This may cover a period shorter than 1 s for transient stability or several seconds for dynamic stability studies.

4.9.3.3.1 Classical model

The classical model for a transient stability study consists of a simple constant voltage source behind a constant transient reactance as in Figure 4-24 (b). This model neglects the following factors by assuming the following:

- a) The shaft mechanical power remains constant
- b) Field flux linkages remain constant
- c) Damping is nonexistent
- d) The constant voltage and reactance are not affected by speed variations
- e) The rotor mechanical angle coincides with the phase angle of the internal voltage

Ignoring dynamic stability effects sometimes associated with high-speed exciter systems, a system found stable under these assumptions will likely be stable if any or all of the above factors are taken into consideration. However, due to exciter effects and in cases where the above analysis suggests instability, there is a need to account for the neglected factors along with regulator action in certain circumstances. The various models, in increasing degree of sophistication, will be presented with simple explanations, if possible, or without explanations, in which case references will be given for the reader to consult.

4.9.3.3.2 The H constant

Stability studies are concerned with relative speed variations of rotating masses. The kinetic energy of a rotating mass, using units of Table 4-7, is as follows:

$$\text{KE} = \frac{1}{2}I\omega^2 = \frac{1}{2}M\omega J \quad (4-77)$$

The rotating mass associated with a generator includes the rotor, shaft, coupling, turbine, and exciter, if the rotating type is used. Since this mass is designed to rotate at a fixed (synchronous) speed, the stored energy, at synchronous speed, of a given machine is used as a constant. This constant is usually normalized by defining a quantity H that expresses the stored energy per unit of machine rated power. If kinetic energy is in megajoules (MJ) and the rated power S in megavoltamperes (MVA), the H constant will be

$$H = \frac{\text{KE}}{S} = \frac{\text{J}}{\text{VA}}$$

Since 1 joule (J) is equal to 1 watt-second (Ws), the H constant is sometimes stated in equivalent kilowatt-second (kWs) per kVA units.

To calculate the H constant, use the following:

$$H = 0.231 \frac{(\text{WR}^2)(\text{r/min})^2 \times 10^{-3}}{\text{MVA}} \quad (4-78)$$

where WR^2 is the moment of inertia in pounds-feet squared and r/min is the speed in revolutions per minute. The H constant values will fall within the narrow range of approximately 1 to 15, irrespective of the size of the machines.

4.9.3.3 Stability model variations

In the discussion of 4.9.3.2, only the direct-axis parameters were considered on the basis that short circuits produce currents of low power factor (quadrature currents predominate). This assumption may not be acceptable for disturbances considered in stability analysis. Therefore, additional synchronous machine parameters are required to more accurately model the behavior and account for the differences in the magnetic construction types, such as salient poles, smooth rotor, laminated rotor, solid iron rotor, with or without dampers.

Quadrature-axis reactances and open-circuit time constants are defined for that purpose. Chapter 1 of Kimbark [B18] is especially recommended as a clear and basic text on the subject.

The classical model may be improved one step by taking account of the variation of machine impedance with time from its initial value, X'_d , to a steady-state value of X_d . The variation will be an exponential described by a time constant T'_{do} (transient, open-circuit time constant). The three parameters X_d , X'_d and T'_{do} will ignore the major effect of dampers.

Another improvement will involve adding the effect of dampers that predominate during fast changing conditions, that is, the subtransient state. The additional parameters X''_d and T''_{do} will take care of this effect.

The saliency of the rotor will be represented by the quadrature-axis parameters, X_q , X'_q , and X''_q and the associated time constants T'_{qo} and T''_{qo} .

Adding the parameters X'_{q0} and T'_{q0} to those of the first improved model will increase the accuracy in the case of a generator with a solid iron rotor. But, as before, the damping effect will have been mostly neglected. The solid iron rotor will be fully represented by all direct- and quadrature-axis, synchronous, transient, and subtransient reactances and associated time constants.

The transient quadrature-axis reactance of salient pole machines has the same value as the equivalent synchronous reactance. Thus salient pole machines can be fully modeled as the solid iron rotor machine by omission of the X'_{q0} and T'_{q0} parameters.

4.9.3.3.4 Exciter models

Various IEEE committees have developed a number of models to represent excitation systems for stability studies. These models have been updated and published as IEEE Std 421.5-1992. Both this standard and its predecessors (IEEE Committee Reports [B8] and [B11]) should be consulted for their description of excitation system models for stability studies and for their tutorial value.

Figure 4-26 shows a standard model that is available with some minor modifications in IEEE Std 421.5-1992 and IEEE Committee Reports [B8] and [B11]. This model is listed as type DC1A, DC1, and type 1, respectively, in each of the aforementioned references.

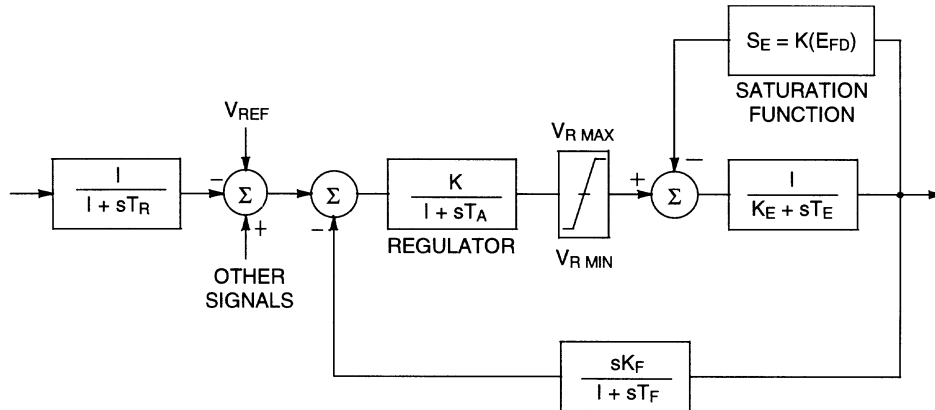

Figure 4-26—IEEE type 1 excitation system

IEEE Committee Report [B13] discusses the transfer function blocks and their practical interpretation as well as other topics related to system response. It is vital to recognize that excitation system models relate the output signal (the synchronous machine field current) to the error signal, which is most commonly the difference between a reference voltage and the synchronous machine terminal voltage. Any transfer function that succeeds in giving the proper relationship is satisfactory for the purpose of a system-wide stability study. Consequently, there are many models with widely varying parameters that will give identical

results. This has the important ramification that typical data for excitation systems are difficult to define. One result is that IEEE Std 421.5-1992 gives sample data and carefully eschews the use of the word typical.

If typical data must be employed, the following guidelines need to be carefully observed:

- If you have data for a particular model, use that model in your study. Do not attempt to apply data for one model to a different model. For example, do not use data for a type 1 model from IEEE Committee Report [B11] in a model from IEEE Std 421.5-1992. Many generators and their excitation systems are older than the respective standards. Consequently, unless someone has made tests explicitly to define parameters for one of the models in the newer standards, you should use the older model for which you have data.
- Notwithstanding the above, if you are able, select a model that corresponds to the type of excitation system that you are to model. In general, there are three distinctive types of excitation systems that are identified on the basis of their excitation power source. These are type DC, which utilizes a direct current generator with a commutator as the source of excitation power; type AC, which uses an alternator and either a stationary or rotating rectifier; and type ST, which uses transformers or auxiliary windings and rectifiers. If possible, or particularly if tests are made, use a model corresponding to the kind of excitation system that is to be modeled.
- Beware of the per-unit system. The standard for excitation models calls for the voltage base of the excitation system to be defined so that one per-unit exciter output voltage is that voltage required to produce rated generator voltage on the generator air gap line. Strictly speaking, the parameters for a particular excitation system cannot be defined without knowing the parameters of the synchronous machine it supplies. Most typical data are given assuming that the full-load field voltage (E_{fdfl}) will be 3.0 per unit. If it is not, the numerical data should be corrected. You should also be careful because different manufacturers use a different base for the voltage amplifier block. While either system works, the numerical values for gains and limits vary widely. Unless you understand the basis used, do not combine data from different sources.
- Certain parameters such as feedback gains are not inherent in the equipment, but represent user-definable gains that are set to maintain excitation system or power system stability. These can often be set by assuming midpoint operation or zero gain during normal operations. However, beware that if you make this assumption, you may be misrepresenting some parameters that perhaps have been incorrectly set in the field, with potentially grave implications for the operation of the power system.

If you must use typical data, an excellent reference is Anderson and Fouad [B2].

Many models have a provision for modeling the saturation that occurs when the excitation current exceeds a certain level. Figure 4-27 shows the standard representation for loaded saturation representation. Computer programs usually account for the related nonlinearity of the air-gap voltage and field current from input data representing two points on the saturation curve defined by the equation in the figure. Refer to the program instructions for information on which two points to use.

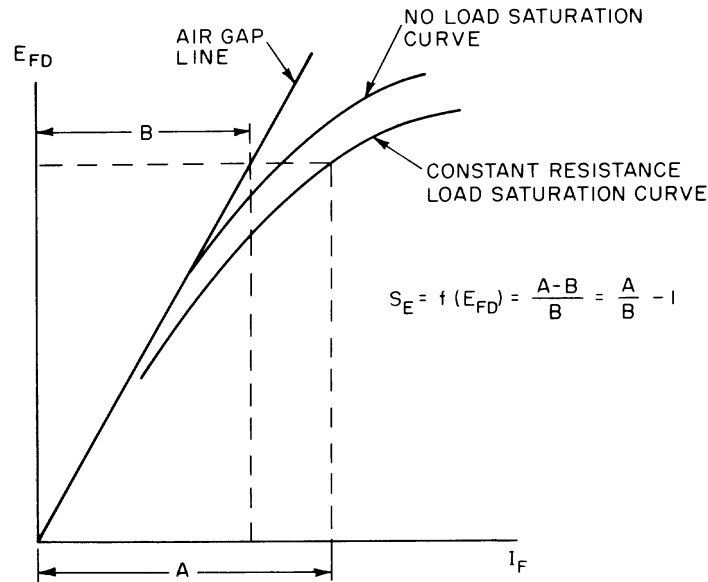

Figure 4-27—Saturation curves

Note also that certain models in the newer standard (all type AC except AC5A) require the use of the no-load saturation curve.

4.9.3.3.5 Prime movers and governor models

Basic models for speed-governing systems and turbines in power system stability studies have been presented in an IEEE Committee Report [B12]. As mentioned earlier, the models are in the form of block diagrams with transfer functions describing the system components' performance. Two more papers, Eggenberger [B4] and Ramey and Skooglund [B21] cover some of the basics and will help the novice understand the relationships between the physical elements and the transfer functions.

Typical parameter values are also available in these references. Of course, analysts will be well advised to seek from the manufacturer the data applicable to their equipment before compromising with typical data.

4.9.4 Miscellaneous bus element models

4.9.4.1 Lighting and electric heating

Lighting and electric heating often constitute a large section of a plant load, particularly in commercial buildings. This type of load can be modeled as constant admittance as suggested by Figures 4-10, 4-11, and 4-12 of the *Industrial Power Systems Handbook* [B16]. The

constant admittance model would seem appropriate for fluorescent and mercury vapor lighting as well as for incandescent lighting. In utility type networks where substations are equipped with voltage regulators, lighting and heating can be represented as constant $P + jQ$.

To calculate the admittances, determine the watts P and vars Q at rated voltage V and solve

$$Y(\text{seimens}) = \frac{P + jQ}{E^2}$$

The fluorescent and mercury vapor lighting power factors will be determined from manufacturers' data in order to calculate the vars Q . Incandescent lights and electric heating will have unity power factors.

4.9.4.2 Electric furnaces

In load flow studies, this load will usually be represented by constant power that will reflect a desired controlled operating condition to be analyzed. In the case of short-circuit and stability studies, the electric furnaces may behave like a constant impedance load. It is unlikely that automatic load tap changers and electrode position controls will have had time to change from the prefault condition to the end of the period covered in transient stability studies. This may very well be the case also in dynamic stability studies extending to several seconds. Because furnace loads can be a large section of a plant load, it is important that the constant impedance model be specified in stability problems because of its damping effect on the power system.

4.9.4.3 Shunt capacitors

Banks of capacitors are used extensively to correct power factors and, as a result, improve voltage regulation at the point of connection. They are modeled simply by a constant shunt capacitive susceptance.

$$jB = j2\pi f C$$

where C is in farads, f is in hertz, and B is in siemens.

Often the capacitors will be specified in kvars. The rated voltage of the bus to which the capacitors are connected must be known whether the susceptance or the equivalent kvar value at the base voltage is used in the study. Remember that kvars vary proportionally with the square of the voltage for a constant susceptance.

4.9.4.4 Shunt reactors

These are seldom used in industrial power systems. A constant admittance would be the correct model for reactors that do not saturate. The same voltage considerations as in the previous paragraph would apply.

4.10 References

This chapter shall be used in conjunction with the following publications. When the following standards are superseded by an approved revision, the revision shall apply.

IEEE Std 58-1978, IEEE Standard Induction Motor Letter Symbols.³

IEEE Std 86-1987, IEEE Recommended Practice: Definitions of Basic Per-Unit Quantities for AC Rotating Machines.⁴

IEEE Std 112-1996, IEEE Standard Test Procedure for Polyphase Induction Motors and Generators.⁵

IEEE Std 115-1995, IEEE Guide: Test Procedures for Synchronous Machines, Part I—Acceptance and Performance Testing, Part II—Test Procedures and Parameter Determination for Dynamic Analysis.

IEEE Std 122-1991, IEEE Recommended Practice for Functional Performance Characteristics of Control Systems for Steam Turbine Generator Units.

IEEE Std 421.5-1992, IEEE Recommended Practice for Excitation Systems for Power System Stability Studies.

IEEE Std 1110-1991, IEEE Guide for Synchronous Generator Modeling Practices in Stability Analysis.

IEEE Std C37.010-1979 (Reaff 1988), Application Guide for AC High-Voltage Circuit Breakers Rated on a Symmetrical Current Basis.

IEEE Std C37.04-1979 (Reaff 1989), IEEE Standard Rating Structure for AC High-Voltage Circuit Breakers Rated on a Symmetrical Current Basis.

IEEE Std C57.12.80-1978 (Reaff 1992), Terminology for Power and Distribution Transformers.

³IEEE Std 58-1978 has been withdrawn; however, copies can be obtained from Global Engineering, 15 Inverness Way East, Englewood, CO 80112-5704, USA, tel. (303) 792-2181.

⁴IEEE Std 86-1987 has been withdrawn; however, copies can be obtained from Global Engineering, 15 Inverness Way East, Englewood, CO 80112-5704, USA, tel. (303) 792-2181.

⁵IEEE publications are available from the Institute of Electrical and Electronics Engineers, 445 Hoes Lane, P.O. Box 1331, Piscataway, NJ 08855-1331, USA.

4.11 Bibliography

Additional information may be found in the following sources:

[B1] Adler, R. B., and Mosher, C. C., "Steady State Power Characteristics for Power System Loads," IEEE Paper 70CP 706-PWR, 1970.

[B2] Anderson, P. M., and Fouad, A. A., *Power System Control and Stability*, New Jersey: IEEE Press, 1994 (revised printing).

[B3] *Aluminum Electrical Conductor Handbook*, The Aluminum Association, 750 Third Ave., New York, 1971.

[B4] Eggenberger, M. A., "A simplified analysis of the no-load stability of mechanical-hydraulic speed control systems for steam turbines," ASME Paper 60-WA-34.

[B5] *Electrical Transmission and Distribution Reference Book*, East Pittsburgh, PA, Westinghouse Electric Corporation, 1964.

[B6] Fitzgerald, A. E., Kingsley, Jr., C., and Umans, S. D., *Electric Machinery*, Fifth Edition, New York, McGraw-Hill, 1990.

[B7] Huening, Jr., W. C., "Interpretation of new American national standards for power circuit breaker applications," *IEEE Transactions on Industry and General Applications*, Sept./Oct. 1969.

[B8] IEEE Committee Report, "Excitation system models for power system stability studies," *IEEE Transactions on Power Apparatus and Systems*, vol. PAS-100, no. 2, Feb. 1981.

[B9] IEEE Committee Report, "Current usage and suggested practices in power system stability simulations for synchronous machines," *IEEE Transactions on Energy Conversion*, vol. EC-1, Mar. 1986, pp. 77-93.

[B10] IEEE Committee Report, "Dynamic models for fossil fueled steam units in power system studies," *IEEE Transactions on Power Systems*, vol. 6, no. 2, May 1991, pp. 753-761.

[B11] IEEE Committee Report, "Computer representation of excitation systems," *IEEE Transactions on Power Apparatus and Systems*, June 1968.

[B12] IEEE Committee Report, "Dynamic models for steam and hydro turbines in power system studies," *IEEE Transactions on Power Apparatus and Systems*, Nov./Dec. 1973.

[B13] IEEE Committee Report, "Excitation system dynamic characteristics," *IEEE Transactions on Power Apparatus and Systems*, Jan./Feb. 1973.

- [B14] IEEE Committee Report, "System load dynamics—simulation effects and determination of load constants," *IEEE Transactions on Power Apparatus and Systems*, Mar./Apr. 1973.
- [B15] Ilicito, F., Ceyhan, A., and Ruckstuhl, G., "Behavior of loads during voltage dips encountered in stability studies—field and laboratory tests," *IEEE Transactions on Power Apparatus and Systems*, Nov./Dec. 1972.
- [B16] *Industrial Power Systems Handbook*, Beeman, D., editor, New York: McGraw-Hill, 1955.
- [B17] Kent, M. H., Schmus, W. R., McCrackin, F. A., and Wheeler, L. M., "Dynamic modeling of loads in the stability studies," *IEEE Transactions on Power Apparatus and Systems*, May 1969.
- [B18] Kimbark, E. W., *Power System Stability: Synchronous Machines*, vol. 3, New Jersey: IEEE Press, 1995 (revised printing).
- [B19] McFarland, T. C., and Van Nostrand, D., *Alternating-Current Machines*, New York: John Wiley & Sons, 1948.
- [B20] Puchstein, A. F., and Lloyd, T. C., *Alternating-Current Machines*, New York: John Wiley & Sons, 1974.
- [B21] Ramey, D. G., and Skooglund, J. W., "Detailed hydrogovernor representation for system stability studies," *IEEE Transactions on Power Apparatus and Systems*, Jan. 1970.
- [B22] *Standard Handbook for Electrical Engineers*, Fink and Beatty, editors, New York: McGraw-Hill, 12th edition.
- [B23] Stevenson, Jr., W. D., *Elements of Power System Analysis*, Third Edition, New York: McGraw-Hill, 1975.

Chapter 5

Computer solutions and systems

5.1 Introduction

Serious power system analysis work requires the use of computers and specialized programs. Hand calculations are suitable for estimating the operating characteristics of a few individual circuits; but accurate calculation of voltages, power flows, or short-circuit currents throughout an industrial or commercial power system would be impractical without the use of computer programs. The various types of power system studies, as described in the following chapters generally involve developing mathematical models in terms of algebraic or differential equations and then solving the equations for numerous design conditions. Computer-aided analysis permits the engineer to focus on power system operation rather than on numerical manipulations.

Success in selecting and applying computer techniques requires the engineer to be familiar with the power system problem as well as many computer hardware and software considerations. The purpose of this chapter is to acquaint prospective users of computer methods in power system analysis with the available types of hardware and software resources. In particular, commonly used numerical methods are introduced to provide insight into how computer programs manipulate large quantities of power system data and determine accurate solutions for various kinds of equations. This chapter is not intended to explain in detail how to write computer programs for power system analysis. For those so inclined, numerous books are devoted to power system analysis programming (see Arrillaga, Arnold, and Harker [B2],¹ Heydt [B18], Kusic [B19], Stagg and El-Abiad [B32], Wallach [B36]).

Digital computers were first used for small power system problems in the late 1940s; but it was not until the availability of large-scale computers in the mid 1950s that power system analysis programs became really useful. Before this time, system studies were performed using special-purpose analog computers, called network analyzers or network calculators, which were introduced in 1929 (Gonen [B12]). Power system studies were limited to hand calculations, assisted by slide rule, before 1929. The development of digital computer technology has been remarkable. Currently, it is common to find computers many times more powerful than the room-filling machines of the 1950s on the desks of individual engineers. Steady advancements have also been made in numerical methods and computer programming.

The advancements in computer technology, particularly as reflected in shrinking computing costs, have brought many engineers into direct contact with computers for the first time. Most find the experience rewarding, if approached with patience. Computers and power system analysis programs have become more readily available and easier to use. Unfortunately, it is still easy to get erroneous results from computer programs. Technology has done little to invalidate the maxim, “garbage in, garbage out.” Data used in a study must be carefully assembled and checked for input errors. The impact of errors in any assumptions made by the

¹The numbers in brackets correspond to those of the bibliography in 5.4

user or by the program (e.g., default values) should be considered. Modeling and solution techniques should be understood. In general, it is important to exercise engineering judgment when reviewing computer results and avoid the tendency to blindly accept numbers on a printout.

5.2 Numerical solution techniques

Computer programs for power system analysis use efficient numerical methods that permit a standardized step-by-step approach to setting up and solving equations. Methodical procedures are required in general-purpose computer programs designed for solving complex engineering problems. Such programs adapt, within limits, to the size of the problem at hand. For example, a load flow analysis program might be designed to handle systems with only two buses or as many as 1000. Matrix methods are essential for achieving this flexibility and orderliness.

5.2.1 Matrix algebra fundamentals

A *matrix* is a rectangular array of numbers arranged in rows and columns enclosed by square brackets or large parentheses. The numbers in a matrix, called *elements*, may be real or complex. The *dimension* of a matrix is expressed as $m \times n$ (read “ m by n ”) if the matrix has m rows and n columns. If a matrix has only one row, it is called a *row matrix* or *row vector*. Similarly, a matrix with a single column is known as a *column matrix* or *column vector*. A matrix is often denoted by a capital, bold-faced letter such as \mathbf{A} , and an element in the matrix is represented as a_{ij} , where i is the row number and j is the column number. For example,

$$\mathbf{A} = \begin{bmatrix} a_{11} & a_{12} & \cdots & a_{1n} \\ a_{21} & a_{22} & \cdots & a_{2n} \\ \cdot & \cdot & & \cdot \\ \cdot & \cdot & & \cdot \\ \cdot & \cdot & & \cdot \\ a_{m1} & a_{m2} & \cdots & a_{mn} \end{bmatrix}$$

If $m = n$, the matrix is called a *square matrix* of *order* n . The elements of a square matrix for which $i = j$ are called *diagonal elements*. The other elements in a square matrix are referred to as *off-diagonal elements*. If corresponding off-diagonal elements are equal (i.e., $a_{ij} = a_{ji}$), the matrix is a *symmetric matrix*. For example,

$$\begin{bmatrix} 3 & 6 & 2 & 7 \\ 6 & 5 & 1 & 5 \\ 2 & 1 & 4 & 8 \\ 7 & 5 & 8 & 9 \end{bmatrix}$$

is a symmetric matrix of order 4 (dimension 4×4).

Two matrices are *equal* if they have the same dimension and the corresponding elements in each matrix are equal. If the rows and columns of a matrix \mathbf{A} are interchanged, the resulting matrix is called the *transpose* of \mathbf{A} and is denoted by \mathbf{A}^T . If \mathbf{A} is a symmetric matrix, then $\mathbf{A} = \mathbf{A}^T$.

Addition and *subtraction* of matrices are valid only for matrices of the same dimension. The *sum*, $\mathbf{A} + \mathbf{B} = \mathbf{C}$, is carried out for each element in \mathbf{C} as $c_{ij} = a_{ij} + b_{ij}$. The order of addition does not matter (i.e., $\mathbf{A} + \mathbf{B} = \mathbf{B} + \mathbf{A}$). Similarly, the *difference*, $\mathbf{A} - \mathbf{B} = \mathbf{C}$, is determined by calculating each element in \mathbf{C} as $c_{ij} = a_{ij} - b_{ij}$.

Multiplication of a matrix by a number (or *scalar*) is valid for any matrix. The *product*, $k\mathbf{A} = \mathbf{B}$, is found by multiplying each element in \mathbf{A} by the number k (i.e., $b_{ij} = ka_{ij}$). Multiplication of two matrices, $\mathbf{AB} = \mathbf{C}$, is valid only if the number of columns in \mathbf{A} equals the number of rows in \mathbf{B} . If \mathbf{A} is a matrix of dimension $m \times n$ and \mathbf{B} is a matrix of dimension $n \times p$, then the product \mathbf{C} is a matrix of dimension $m \times p$. Each element of \mathbf{C} is calculated as follows:

$$c_{ij} = a_{i1} b_{1j} + a_{i2} b_{2j} + \dots + a_{in} b_{nj}$$

For example, if

$$\mathbf{A} = \begin{bmatrix} 1 & 2 & 3 \\ 4 & 5 & 6 \\ 7 & 8 & 9 \end{bmatrix} \text{ and } \mathbf{B} = \begin{bmatrix} u & x \\ v & y \\ w & z \end{bmatrix} \text{ then}$$

$$\mathbf{AB} = \begin{bmatrix} u + 2v + 3w & x + 2y + 3z \\ 4u + 5v + 6w & 4x + 5y + 6z \\ 7u + 8v + 9w & 7x + 8y + 9z \end{bmatrix} = \mathbf{C}$$

If the product \mathbf{AB} is valid, then \mathbf{BA} is valid only if \mathbf{A} and \mathbf{B} are square matrices of the same order. In general, the products \mathbf{AB} and \mathbf{BA} are not equal. An exception is when \mathbf{B} is equal to the *unit matrix* \mathbf{U} . The unit matrix is a square matrix of the same order as \mathbf{A} in which all diagonal elements equal 1 and all off-diagonal elements are 0. In this case, $\mathbf{AU} = \mathbf{UA} = \mathbf{A}$. For example:

$$\begin{bmatrix} 8 & 3 \\ 5 & 2 \end{bmatrix} \begin{bmatrix} 1 & 0 \\ 0 & 1 \end{bmatrix} = \begin{bmatrix} 1 & 0 \\ 0 & 1 \end{bmatrix} \begin{bmatrix} 8 & 3 \\ 5 & 2 \end{bmatrix} = \begin{bmatrix} 8 & 3 \\ 5 & 2 \end{bmatrix}$$

The only form of division defined in matrix algebra is division of a matrix by a scalar k . This is equivalent to multiplication of a matrix by the reciprocal, or *inverse*, of the number k^{-1} . Given the matrix expression $\mathbf{AX} = \mathbf{B}$ in which the elements of \mathbf{X} are unknown, a solution $\mathbf{X} = \mathbf{A}^{-1}\mathbf{B}$ may exist where \mathbf{A}^{-1} is the inverse of the square matrix \mathbf{A} . If \mathbf{A}^{-1} exists, it is a square matrix of the same order as \mathbf{A} , and it satisfies the condition $\mathbf{A}^{-1}\mathbf{A} = \mathbf{AA}^{-1} = \mathbf{U}$, where \mathbf{U} is the

unit matrix. This definition implies a method for determining the inverse of a matrix. For example:

$$\text{If } \mathbf{A} = \begin{bmatrix} 8 & 3 \\ 5 & 2 \end{bmatrix} \text{ let } \mathbf{A}^{-1} = \begin{bmatrix} w & y \\ x & z \end{bmatrix}$$

$$\text{Then } \mathbf{AA}^{-1} = \begin{bmatrix} 8w + 3x & 8y + 3z \\ 5w + 2x & 5y + 2z \end{bmatrix} = \begin{bmatrix} 1 & 0 \\ 0 & 1 \end{bmatrix}$$

$$\text{The resulting equations } \begin{array}{l} 8w + 3x = 1 \quad 8y + 3z = 0 \\ 5w + 2x = 0 \quad 5y + 2z = 1 \end{array}$$

have the solution $w = 2, x = -5, y = -3, z = 8$.

$$\text{Therefore } \mathbf{A}^{-1} = \begin{bmatrix} 2 & -3 \\ -5 & 8 \end{bmatrix}$$

Matrix inversion can be used to solve simultaneous algebraic equations. This will be described later along with a more practical method for finding the inverse of a matrix.

An operation that is useful for simplifying computations with a large matrix or for showing the specific structure of a matrix is called *partitioning*. A partitioned matrix is divided by horizontal and vertical lines into *submatrices* that are treated as single elements in addition, subtraction, and multiplication. For example, the 3×3 matrix \mathbf{A} shown below can be partitioned into four submatrices $\mathbf{A}_1, \mathbf{A}_2, \mathbf{A}_3$, and \mathbf{A}_4 .

$$\mathbf{A} = \left[\begin{array}{cc|c} 1 & 2 & 3 \\ 4 & 5 & 6 \\ 7 & 8 & 9 \end{array} \right] = \begin{bmatrix} \mathbf{A}_1 & \mathbf{A}_2 \\ \mathbf{A}_3 & \mathbf{A}_4 \end{bmatrix}$$

A column vector \mathbf{B} can be partitioned to facilitate multiplication by \mathbf{A} .

$$\mathbf{B} = \begin{bmatrix} 3 \\ 2 \\ 1 \end{bmatrix} = \begin{bmatrix} \mathbf{B}_1 \\ \mathbf{B}_2 \end{bmatrix}$$

$$\mathbf{AB} = \begin{bmatrix} \mathbf{A}_1 & \mathbf{A}_2 \\ \mathbf{A}_3 & \mathbf{A}_4 \end{bmatrix} \begin{bmatrix} \mathbf{B}_1 \\ \mathbf{B}_2 \end{bmatrix} = \mathbf{C} = \begin{bmatrix} \mathbf{C}_1 \\ \mathbf{C}_2 \end{bmatrix}$$

The submatrix \mathbf{C}_2 , which consists of a single element for this partitioning, can be determined as follows:

$$\begin{aligned}\mathbf{C}_2 &= \mathbf{A}_3\mathbf{B}_1 + \mathbf{A}_4\mathbf{B}_2 = [7 \ 8] \begin{bmatrix} 3 \\ 2 \end{bmatrix} + [9] [1] \\ &= 21 + 16 + 9 = 46\end{aligned}$$

The original matrices and corresponding submatrices must be compatible for multiplication, addition, or subtraction if one of these operations is to be performed on partitioned matrices. Special techniques for finding the transpose and the inverse of a matrix by operating on its submatrices are also available (Stagg and El-Abiad [B32]).

Only the fundamental definitions in matrix algebra have been presented here. Comprehensive information is available in numerous books on mathematics and electrical circuits (Groza and Shelley [B15], Spiegel [B31], Stagg and El-Abiad [B32], Stevenson [B34]).

5.2.2 Power system network matrices

The matrices used in computer programs for several types of power system analysis are based on the mesh-current and node-voltage analysis methods described in introductory electrical circuit theory texts (Edminister [B8], Hayt and Kemmerly [B17], Scott [B29]). In power systems work, the terms *loop* and *bus* are frequently used in place of mesh and node, respectively. The simple, three-bus power system shown in the single-line diagram of Figure 5-1 will be used to explain these methods. Resistance is neglected in the discussion in order to keep the arithmetic easier to follow, although computer programs are normally written to use both resistance and reactance in calculations.

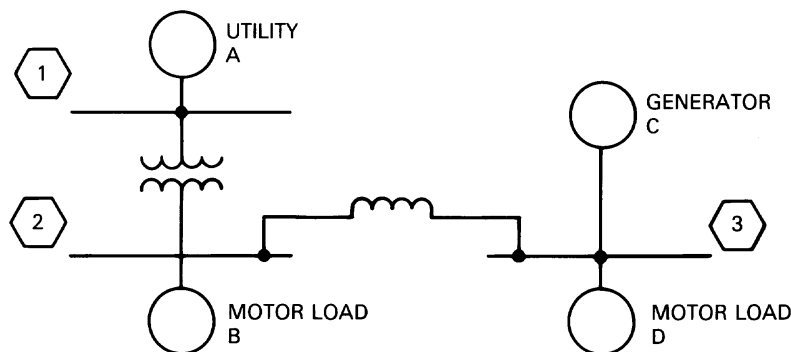

Figure 5-1—Single-line diagram

A single-phase equivalent impedance diagram is the basis for the loop current analysis method. Generators and motors are represented as series reactances and emfs connected to the neutral bus. The values of the series reactances will vary depending on whether a transient or steady-state analysis is required. A per unit impedance diagram for the system of Figure 5-1 is shown in Figure 5-2. Three loop currents, I_1 , I_2 , and I_3 , are shown circulating clockwise within each loop. Kirchoff's voltage law, which states that the sum of the potential differences around a closed circuit loop is 0, is applied to the loop indicated by I_1 . This can be repeated for the other two loops, but the equations can be expressed directly in standard matrix form. The voltage matrix V_{LOOP} includes the total emf rise around each loop in the direction assumed positive for the loop current. The impedance matrix Z_{LOOP} consists of *self-impedances* and *mutual impedances*. The impedances Z_{11} , Z_{22} , and Z_{33} are the self-impedances that equal the sum of the impedances in loops 1, 2, and 3, respectively. The other impedances are the mutual impedances that equal the negative of the impedance common to two loops. For example, $Z_{23} = Z_{32} = -j2.5$, the negative of the impedance common to loops 2 and 3. If the direction assumed positive for *one* of the currents had been counterclockwise, then the loop currents would flow in the same direction through the common impedance, and the mutual impedance would be positive. It is important to realize that the voltage, current, and impedance subscripts refer to loops, not buses.

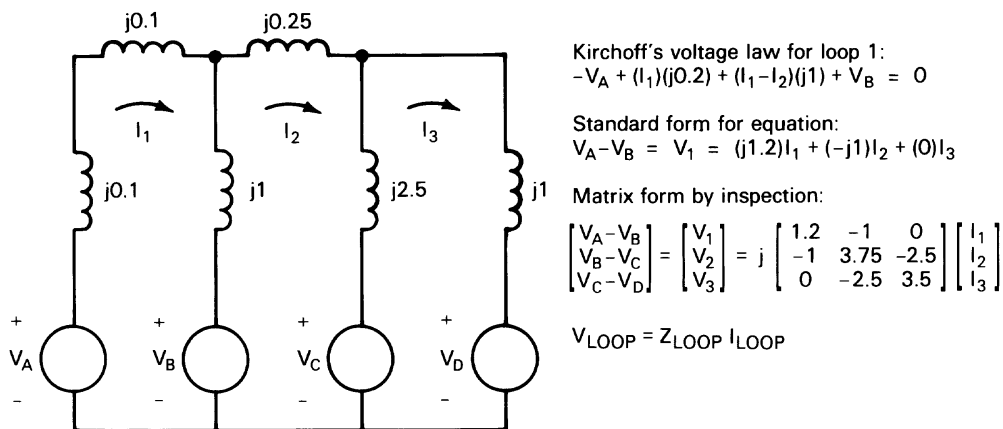

Figure 5-2—Impedance diagram and mesh (loop) current analysis

An analysis based on the node-voltage method directly references bus quantities. Most power system analysis programs work with bus, rather than loop, quantities. Since the node-voltage method uses admittances instead of impedances, the impedance diagram in Figure 5-2 has been converted to the admittance diagram in Figure 5-3. Voltage sources with series impedances are converted to equivalent current sources with shunt impedances using well-known methods. The shunt impedances equal the series impedances, and currents are calculated as the voltages divided by the series impedances (i.e., $I_1 = V_A / j0.1$, $I_2 = V_B / j1$, $I_3 = V_C / j2.5 + V_D / j1$). Individual admittances are calculated as reciprocals of the corresponding impedances. Kirchoff's current law, which states that the sum of the currents entering a node equals the sum of the currents leaving the node, can now be applied to bus 1. This is shown in

Figure 5-3. Bus voltages V_1 , V_2 , and V_3 are with respect to the neutral reference bus. Currents leaving a node are expressed as the potential difference across a branch multiplied by the admittance of the branch. The resulting current equations can be written in a standard form suitable for matrix methods. The *bus admittance matrix* \mathbf{Y}_{BUS} consists of *self-admittances* and *mutual admittances*. The self-admittances, Y_{11} , Y_{22} , and Y_{33} , are each equal to the sum of the admittances connected to the node identified by the double subscripts. The mutual admittances are each equal to the negative of the admittance between the two nodes indicated by the subscripts (e.g., $Y_{12} = Y_{21} = j10$).

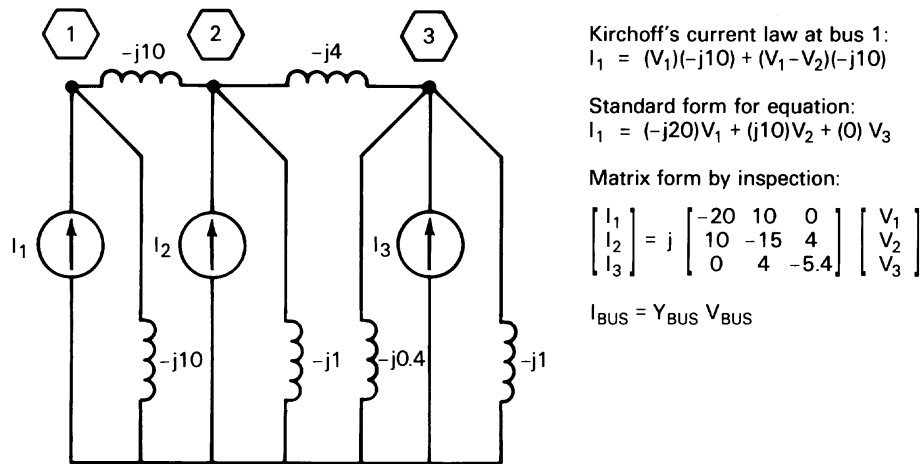

Figure 5-3—Admittance diagram and node (bus) voltage analysis

The admittances in the bus admittance matrix are not reciprocals of the impedances in the loop impedance matrix, nor are the two matrices inverses of each other. However, the *bus impedance matrix* \mathbf{Z}_{BUS} is defined to be the inverse of the bus admittance matrix \mathbf{Y}_{BUS} . The diagonal elements of \mathbf{Z}_{BUS} are called *driving-point impedances*, and the off-diagonal elements are known as *transfer impedances*. Although the bus impedance matrix cannot be determined from a simple impedance diagram, efficient algorithms for developing \mathbf{Z}_{BUS} directly from a list of impedance elements are available (Brown, Person, Kirchmayer, and Stagg [B3], Stagg and El-Abiad [B32]). The bus impedance matrix is widely used in short-circuit calculation programs. The bus admittance matrix is often used in programs for load flow analysis.

Certain properties of power system network matrices are exploited to improve the efficiency of computer programs (Heydt [B18]). The fact that impedance and admittance matrices are symmetric allows a reduction in computer memory for this data of nearly 50%. Only the diagonal elements and the elements above the diagonal need be stored since $Y_{ji} = Y_{ij}$ and $Z_{ji} = Z_{ij}$. Symmetry may be compromised if phase-shifting transformers are modeled. Another matrix property that can be used to reduce storage requirements is known as *sparsity*. A matrix is sparse if most of its elements are 0. The bus admittance matrix is usually very sparse since each bus is connected through a branch (nonzero mutual admittance) to only a few

other buses. A row or column of \mathbf{Y}_{BUS} contains 3 to 4 nonzero entries, on average. Consequently, at least 96% of the elements in the bus admittance matrix for a typical 100 bus system are 0. The bus impedance matrix, in contrast, frequently contains no zero elements. Programs which take advantage of sparsity may store only the nonzero elements along with the row-column locations of those entries. Also, numerical techniques have been developed that are especially effective in performing operations on sparse matrices.

Matrix partitioning is also useful for reducing computer storage and processing requirements. One particularly powerful application of partitioning is *network reduction*. Buses that are not connected to current sources can be grouped together in submatrices within the expression $\mathbf{I}_{\text{BUS}} + \mathbf{Y}_{\text{BUS}} \mathbf{V}_{\text{BUS}}$. These buses can be eliminated from the expression through a straightforward series of matrix operations (Stevenson [B34]).

There is often a trade-off of increased processing time associated with techniques to reduce computer memory requirements. Extra steps may be required to locate an element to be used in a calculation if it is not stored in standard matrix form. However, some memory reduction schemes are commonly used in power system analysis programs in order to maximize the number of buses that can be handled on a given size computer.

5.2.3 Solution of simultaneous algebraic equations

Modeling of many problems in science, engineering, or business results in systems of simultaneous algebraic equations that must be solved for several unknowns. Simultaneous equations typically exist in cases of interdependent quantities. For example, the current that one conductor in an underground duct bank can carry is dependent on the heat produced by the current flowing in all of the conductors in the duct bank. Similarly, all the voltages and currents of a power system are mutually dependent. The development of the equations and the associated matrix representation (i.e., $\mathbf{I}_{\text{BUS}} = \mathbf{Y}_{\text{BUS}} \mathbf{V}_{\text{BUS}}$) for modeling this relationship has been described. The solution of these equations is the basis for load flow analysis as described in Chapter 6.

Simultaneous algebraic equations may be classified as *linear* or *nonlinear*. In linear equations, the sum of one or more variables of degree 1, each multiplied by a constant coefficient, is equal to a constant. Nonlinear equations may contain variables raised to powers other than 1, division of an expression by a variable, multiplication of two or more variables, or expressions with nonalgebraic functions of variables (e.g., trigonometric). In this context, a linear equation is not just the equation of a line in the xy plane. Systems of linear equations are common in many kinds of analysis even though, by definition, they represent a small subset of all types of equations. Sometimes a linear system of equations becomes nonlinear due to constraints placed on the solution. For example, in the load flow problem, real and reactive power for each bus, rather than bus current, are typically known. When the required substitution ($\mathbf{I} = (\mathbf{P} - j\mathbf{Q})/\mathbf{V}^*$) is made, the equations become nonlinear.

Techniques for solving simultaneous algebraic equations may be described as either *direct* or *iterative* (Stagg and El-Abiad [B32]). Direct methods are applicable to linear systems of equations. Iterative methods may be employed to solve either linear or nonlinear systems of equations. Sometimes a combination of direct and iterative methods is used. Regardless of

method, some type of computer-determined solution becomes almost essential for systems of more than three or four equations.

5.2.3.1 Direct methods

A direct method determines a solution in a predictable number of arithmetic operations. Such methods are also called “exact” since all steps are carried out according to strict mathematical definitions without assuming values for any unknowns. Unfortunately, these methods can be far from exact unless measures are taken to minimize the cumulative effect of round-off errors.

Several direct methods, useful for solving systems of linear equations, involve the use of *determinants*. A determinant is similar to a matrix in that it consists of entries arranged in rows and columns. A determinant is denoted by vertical bars instead of the brackets or parentheses used to indicate a matrix. The main difference between a determinant and a matrix is that a single value can be calculated for a determinant, while the number of entries in a matrix cannot be changed. A determinant is defined based on a system of two linear equations as follows (Spiegel [B31]):

$$a_1x + b_1y = c_1$$

$$a_2x + b_2y = c_2$$

This system of equations, representing two lines in the xy plane, can be solved simultaneously by various algebraic manipulations to find the unknowns x and y , which are the coordinates where the two lines intersect.

$$x = \frac{c_1b_2 - b_1c_2}{a_1b_2 - b_1a_2} \quad y = \frac{a_1c_2 - c_1a_2}{a_1b_2 - b_1a_2}$$

Given the definition of a determinant of order 2,

$$\begin{vmatrix} a & b \\ c & d \end{vmatrix} = ad - bc$$

we can write the solutions for x and y in determinant form.

$$x = \frac{\begin{vmatrix} c_1 & b_1 \\ c_2 & b_2 \end{vmatrix}}{\begin{vmatrix} a_1 & b_1 \\ a_2 & b_2 \end{vmatrix}} \quad y = \frac{\begin{vmatrix} a_1 & c_1 \\ a_2 & c_2 \end{vmatrix}}{\begin{vmatrix} a_1 & b_1 \\ a_2 & b_2 \end{vmatrix}}$$

Examination of these expressions shows that the denominator for both x and y is a determinant containing the coefficients of x and y in the original system of equations. The numerator for x is in the same form, except the coefficients of x are replaced by the constants c_1 and c_2 . Similarly, to write the numerator of y , the coefficients of y are replaced by the constants. This procedure, known as *Cramer's rule*, is applicable to systems of any number of linear equations.

To evaluate a determinant of order greater than 2, some additional definitions are required. Given a square matrix \mathbf{A} of order n , there is an associated determinant, $\det(\mathbf{A})$. Taking any element a_{ij} in \mathbf{A} , a new determinant of order $(n - 1)$ can be obtained by removing row i and column j . This new determinant is called the *minor* of a_{ij} . If the minor of a_{ij} is multiplied by $(-1)^{i+j}$, the result is called the *cofactor* of the element a_{ij} and is denoted A_{ij} . The value of a determinant can be calculated by adding the products $a_{ij}A_{ij}$ for all the elements in any row or column. This rule, called the *Laplace expansion*, is illustrated below to find the determinant associated with the bus admittance matrix developed in Figure 5-3.

$$\det(\mathbf{Y}) = j \begin{vmatrix} -20 & 10 & 0 \\ 10 & -15 & 4 \\ 0 & 4 & -5.4 \end{vmatrix}$$

If this is expanded in terms of cofactors for the first column, the result is as follows:

$$\begin{aligned} \det(\mathbf{Y}) &= -j20(-1)^{1+1} \begin{vmatrix} -15 & 4 \\ 4 & -5.4 \end{vmatrix} + j10(-1)^{2+1} \begin{vmatrix} 10 & 0 \\ 4 & -5.4 \end{vmatrix} + 0 \\ &= -j20(81 - 16) - j10(-54 - 0) = -j760 \end{aligned}$$

Note that the 0 in the first column that was picked for expansion eliminated the need to evaluate the third determinant. A technique for systematically introducing zeros by algebraic manipulations is known as the *Gauss elimination method* (Buchanan and Turner [B4], Burden and Faires [B5], Gerald and Wheatley [B10], Stagg and El-Abiad [B32]). This technique can also be applied directly to a system of linear equations. The result is a coefficient matrix with all diagonal elements equal to 1 and all elements below the diagonal equal to 0. The solution can then be determined by a simple process of *back substitution*. The Gauss elimination method is much more efficient computationally than Cramer's rule. For example, solving a set of 10 simultaneous equations requires about 70 million multiplications and divisions using the Laplace expansion compared to only about 400 multiplications and divisions using Gaussian elimination (Gerald and Wheatley [B10]). An example solution using the Gauss elimination method is included at the end of this section.

Elimination techniques are based on several valid operations for systems of linear equations: (1) any equation may be multiplied by a constant; (2) any equation may be replaced by its sum with another equation; and (3) the order of the equations may be changed. Computer programs reorder rows to avoid dividing by 0 and to minimize round-off errors in calculations. This technique is known as *pivoting*. Variations on the Gauss elimination

method, including LU decomposition, have been developed to reduce computer storage requirements and processing time. The LU decomposition method begins by transforming the coefficient matrix \mathbf{A} into the product of two matrices \mathbf{L} and \mathbf{U} , where \mathbf{L} is a lower triangular matrix with 0's above the diagonal and \mathbf{U} is an upper triangular matrix with 1's on the diagonal and 0's below the diagonal (Gerald and Wheatley [B10]).

Matrix inversion was previously described as a useful technique for solving systems of linear equations. However, the method shown for inverting a matrix only generates more equations that must be solved simultaneously using another method. Now that determinants and cofactors have been introduced, an effective matrix inversion procedure can be presented. If \mathbf{A} is a square matrix and $\det(\mathbf{A})$ is not zero (i.e., \mathbf{A} is *nonsingular*), then a unique inverse \mathbf{A}^{-1} exists that can be expressed as follows:

$$\mathbf{A}^{-1} = \frac{[A_{ij}]^T}{\det(\mathbf{A})}$$

where

$[A_{ij}]$ is the matrix of the cofactors of the corresponding elements a_{ij} in \mathbf{A} .

$[A_{ij}]^T$ indicates its transpose (i.e., its rows and columns are interchanged).

To illustrate this method, a system of equations will be solved by matrix inversion. The basis of the method will be clarified by solving the same equations by Cramer's rule. The system of equations

$$8x_1 + 3x_2 = 14$$

$$5x_1 + 2x_2 = 9$$

can be expressed in matrix form $\mathbf{AX} = \mathbf{B}$ as

$$\begin{bmatrix} 8 & 3 \\ 5 & 2 \end{bmatrix} \begin{bmatrix} x_1 \\ x_2 \end{bmatrix} = \begin{bmatrix} 14 \\ 9 \end{bmatrix}$$

The solution matrix \mathbf{X} can be determined as $\mathbf{X} = \mathbf{A}^{-1}\mathbf{B}$:

$$[A_{ij}]^T = \begin{bmatrix} (-1)^{1+1}(2) & (-1)^{1+2}(5) \\ (-1)^{2+1}(3) & (-1)^{2+2}(8) \end{bmatrix}^T = \begin{bmatrix} 2 & -3 \\ -5 & 8 \end{bmatrix}$$

$$\det(\mathbf{A}) = \begin{vmatrix} 8 & 3 \\ 5 & 2 \end{vmatrix} = (8)(2) - (3)(5) = 1$$

$$\mathbf{A}^{-1} = \frac{[A_{ij}]^T}{\det(\mathbf{A})} = \begin{bmatrix} 2 & -3 \\ -5 & 8 \end{bmatrix}$$

Notice that \mathbf{A}^{-1} matches the matrix determined previously using the fundamental definition of an inverse matrix. Now the solution of the equations can be determined by matrix multiplication.

$$\begin{bmatrix} x_1 \\ x_2 \end{bmatrix} = \begin{bmatrix} 2 & -3 \\ -5 & 8 \end{bmatrix} \begin{bmatrix} 14 \\ 9 \end{bmatrix} = \begin{bmatrix} (2)(14) + (-3)(9) \\ (-5)(14) + (8)(9) \end{bmatrix} = \begin{bmatrix} 1 \\ 2 \end{bmatrix}$$

Using Cramer's rule:

$$x_1 = \frac{\begin{vmatrix} 14 & 3 \\ 9 & 2 \end{vmatrix}}{\begin{vmatrix} 8 & 3 \\ 5 & 2 \end{vmatrix}} = \frac{(14)(2) - (3)(9)}{(8)(2) - (3)(5)} = \frac{1}{1} = 1$$

$$x_2 = \frac{\begin{vmatrix} 8 & 14 \\ 5 & 9 \end{vmatrix}}{1} = \frac{(8)(9) - (14)(5)}{1} = \frac{2}{1} = 2$$

The similarity in the calculations for the two methods shows the common basis for the techniques.

To solve the equations using the Gauss elimination method, augment the coefficient matrix \mathbf{A} with \mathbf{B} .

$$\begin{bmatrix} 8 & 3 & 14 \\ 5 & 2 & 9 \end{bmatrix}$$

Create a 0 in the first column of the second row by multiplying the first row by 5/8 and subtracting the result from the second row.

$$\begin{bmatrix} 8 & 3 & 14 \\ 0 & 1/8 & 1/4 \end{bmatrix}$$

Create 1's on the diagonal of the coefficient matrix by multiplying the first row by 1/8 and the second row by 8.

$$\begin{bmatrix} 1 & 0.375 & 1.75 \\ 0 & 1 & 2 \end{bmatrix}$$

Therefore, $x_2 = 2$ and $x_1 = 1.75 - (0.375)(2) = 1$.

Additional direct methods for solving systems of linear equations are described in bibliographic references (Buchanan and Turner [B4], Burke and Faires [B5], Gerald and Wheatley [B10], Heydt [B18], Maron [B21], Press, Flannery, Teukolsky, and Vetterling [B26], Stagg and El-Abiad [B32]).

5.2.3.2 Iterative methods

Iterative methods for solving linear and non-linear simultaneous algebraic equations are sometimes called “approximate.” Generally, however, a solution determined by an iterative method can be as accurate as required. Also, round-off errors tend to be corrected from one iteration to the next. Useful iterative methods should have the following features (Grove [B14]):

- a) A means for making a satisfactory first guess
- b) A means for systematically improving on previous approximations
- c) A criterion for stopping the iterations when sufficient accuracy has been achieved

The number of successive approximations, or iterations, needed to arrive at a solution of the desired accuracy cannot be predicted in advance. Depending on the nature of the equations, the choice of initial approximations, and the specific solution technique, the successive approximations may converge to an accurate solution quickly or slowly. Sometimes each iteration will cause the approximations to oscillate or become less accurate (i.e., diverge). For some types of problems, one solution technique may fail consistently, while another may provide reliable results. Two commonly used iterative methods, *Gauss-Seidel* and *Newton-Raphson*, are described here in general terms. These methods are widely used in programs for load flow analysis. Specific application considerations and comparison information for these methods, as applied to load flow analysis, are included in Chapter 6.

The *Gauss-Seidel iterative method* is a simple substitution technique in which a variable calculated using one equation is substituted in the following equations to calculate other variables. The calculations are repeated until the results match the previous iteration within a specified tolerance. To implement the Gauss-Seidel method, each equation is rewritten to isolate a different unknown variable. This is shown below for a system of three linear equations.

$$a_{11} x_1 + a_{12} x_2 + a_{13} x_3 = b_1$$

$$a_{21} x_1 + a_{22} x_2 + a_{23} x_3 = b_2$$

$$a_{31} x_1 + a_{32} x_2 + a_{33} x_3 = b_3$$

The variable x_1 can be isolated in the first equation and x_2 and x_3 in the second and third equations, respectively. Provided that the equations are processed sequentially in the order listed, we can also assign a superscript of k or $k + 1$ to indicate the iteration number of the variable being calculated or the variable used in a calculation.

$$x_1^{k+1} = 1/a_{11} (b_1 - a_{12} x_2^k - a_{13} x_3^k)$$

$$x_2^{k+1} = 1/a_{22} (b_2 - a_{21} x_1^{k+1} - a_{23} x_3^k)$$

$$x_3^{k+1} = 1/a_{33} (b_3 - a_{31} x_1^{k+1} - a_{32} x_2^{k+1})$$

The iteration process begins with calculations for iteration number 1 (i.e., $k = 0$). An initial guess for a variable is used if its iteration number is 0. In calculating x_2 for the first iteration, the value just calculated for x_1 is used; but a calculation for x_3 has not yet been made so its initial value is used. Unless the nature of the problem provides a means of guessing initial values, the following is generally used:

$$x_i^0 = b_i / a_{ii} \quad \text{for } i = 1, 2, \dots, n$$

When x_3 is calculated, an iteration is finished. If the changes in the variables from the previous iteration are within the specified tolerance, the procedure is stopped. Otherwise, k is incremented by 1, and calculations for another iteration are performed.

Although this procedure may seem involved, it is quite easy to implement in a computer program. A simple BASIC language program for solving the same system of equations previously solved using direct methods is shown in Figure 5-4. Comments are included in the program listing to clarify the main functions. The program prints iteration number, x_1 , and x_2 , after each iteration. The beginning and ending sections of the printout are also shown in Figure 5-4. Changes in x_1 and x_2 of less than 0.00001 between iterations indicate that the program has converged to a solution of sufficient accuracy. Notice that 151 iterations were required before the solution converged. *Acceleration factors* are often used to speed up convergence with the Gauss-Seidel method. This is done by replacing each new value of x_i with the following accelerated value:

$$\text{accelerated } x_i^{k+1} = x_i^k + a (x_i^{k+1} - x_i^k)$$

where

$$\begin{aligned} \text{acceleration factor} & \quad a = 1.0 \text{ to } 1.8 \\ & \quad i = 1, 2, \dots, n \end{aligned}$$

When this was added to the program of Figure 5-4, the optimum acceleration factor was found to be 1.61, which reduced the required number of iterations to 27. Factors greater than 1.8 caused the solution to diverge. The optimum acceleration factor will vary depending on the nature of the equations. The value 1.6 is commonly used in Gauss-Seidel load flow solutions.

```

100 ' -----
110 '      This BASIC program uses the Gauss-Seidel iterative
120 '      method to solve the following system of equations:
130 '
140 '      8(X1) + 3(X2) = 14
150 '      5(X1) + 2(X2) = 9
160 ' -----
170 DEFINT I          ' Define iteration no. to be an integer
180 TOLER = .00001    ' Set tolerance for convergence check
190 X1 = 14/8         ' Set initial guesses
200 X2 = 9/2         '
210 FOR I = 1 TO 1000 ' Top of Loop (allow 1000 iterations)
220 X1OLD = X1        ' Save results of previous iteration
230 X2OLD = X2        ' to check for convergence
240 X1 = (1/8) * (14-3*X2) ' Calculate new X1
250 X2 = (1/2) * (9-5*X1) ' Calculate new X2
260 LPRINT I,X1,X2   ' Print iteration no. X1 and X2
270                  ' Check for convergence
280 IF ABS(X1-X1OLD) < TOLER THEN GOTO 290 ELSE GOTO 300
290 IF ABS(X2-X2OLD) < TOLER THEN END
300 NEXT I           ' Bottom of Loop

1      .0625      4.34375
2      .1210938   4.197266
3      .1760254   4.059937
4      .2275238   3.931191
5      .2758036   3.810491
6      .3210659   3.697335
7      .3634993   3.591252
8      .4032805   3.491799
9      .4405754   3.398562
10     .4755395   3.311152
.
.
.
140    .9998808   2.000298
141    .9998882   2.000279
142    .9998952   2.000262
143    .9999018   2.000246
144    .9999079   2.00023
145    .9999136   2.000216
146    .999919    2.000202
147    .9999241   2.00019
148    .9999288   2.000178
149    .9999333   2.000167
150    .9999376   2.000156
151    .9999414   2.000146

```

Figure 5-4—Computer program using Gauss-Seidel method

The characteristics of the *Newton-Raphson iterative method* are quite different from those of the Gauss-Seidel method. While the Gauss-Seidel method tends to require a large number of simple iterations, the Newton-Raphson method needs relatively few iterations; but the calculations needed to complete an iteration are extensive. The Newton-Raphson method is only useful for systems of nonlinear equations since solution of a linear system of equations by another method is part of each Newton-Raphson iteration.

Since the Newton-Raphson method is also applicable to one equation in one variable, a graphical development of the procedure based on Figure 5-5 is helpful (Grove [B14]). Given an equation in the form $f(x) = 0$, we can graph the function as $y = f(x)$. The solution of the equation is the x-coordinate where the curve crosses the x-axis (i.e., $y = 0$). If an initial guess at the solution of x_0 is made, the corresponding y-coordinate can be calculated as $y_0 = f(x_0)$. A line tangent to the curve can be drawn at (x_0, y_0) . The x-coordinate (x_1) at which this line crosses the x-axis will be a closer approximation to the actual solution. Analytically, we can take the equation of the tangent line and solve it to find the point $(x_1, 0)$:

$$y - y_0 = \left. \frac{df}{dx} \right|_0 (x - x_0)$$

$$0 - f(x_0) = \left. \frac{df}{dx} \right|_0 (x_1 - x_0)$$

where $\left. \frac{df}{dx} \right|_0$ = the derivative (slope) of the function $f(x)$ with respect to x evaluated at the point (x_0, y_0)

To show the similarity of this equation to that presented later for the case of two equations in two unknowns, it can be rewritten as follows:

$$f(x_0) + \left. \frac{df}{dx} \right|_0 (x_1 - x_0) = 0$$

The function and its derivative can now be evaluated for $x = x_0$ to calculate an improved approximation of the solution:

$$x_1 = x_0 - \frac{f(x_0)}{\left. \frac{df}{dx} \right|_0}$$

This process can be repeated to find x_2 , the next approximation.

This method has been developed based on a graphical approach; but the same result can be obtained by expanding $f(x)$ as a Taylor series about x_0 and truncating the series after the first derivative term. This approach is required to rigorously develop the Newton-Raphson method for multiple equations in multiple unknowns. Here, we will take the case of two equations in

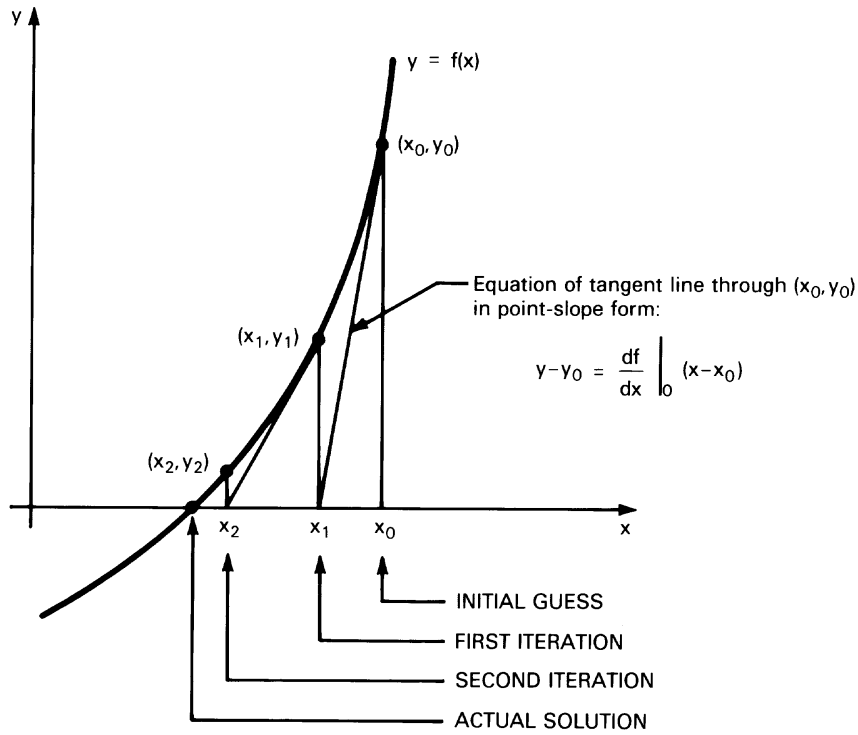

Figure 5-5—Newton-Raphson method to solve an equation of the form $f(x) = 0$

two unknowns and simply write the Newton-Raphson equations using the similarity to the case of one equation in one unknown as justification. Given a system of two equations in the form

$$f(x, y) = 0$$

$$g(x, y) = 0$$

and an initial guess at the solution (x_0, y_0) , the following linear system of equations can be solved simultaneously to find an improved approximation (x_1, y_1) :

$$f(x_0, y_0) + \frac{\partial f}{\partial x} \Big|_0 (x_1 - x_0) + \frac{\partial f}{\partial y} \Big|_0 (y_1 - y_0) = 0$$

$$g(x_0, y_0) + \frac{\partial g}{\partial x} \Big|_0 (x_1 - x_0) + \frac{\partial g}{\partial y} \Big|_0 (y_1 - y_0) = 0$$

These equations contain additional terms because of the second variable; but the form of the equations matches that for the case of one equation in one unknown. Partial derivatives are required since we are now dealing with functions of more than one variable. Although the equations look formidable, everything reduces to simple numbers except the variables x_1 and y_1 .

Iterative methods provide the only means for solving many types of simultaneous algebraic equations. Additional information on this subject may be found in numerous texts about numerical methods (Arbenz and Wohlhauser [B1], Grove [B14], Maron [B21], Press, Flannery, Teukolsky, and Vetterling [B26], Stagg and El-Abiad [B32]).

5.2.4 Solution of differential equations

The dynamic performance of a physical system is described by one or more differential equations. The physical system may be mechanical, electrical, fluidal, thermal, or a combination of these [B4]). For example, in a complex power system transient stability study, differential equations describing synchronous machine rotor positions and speeds, internal voltages, exciter control systems, and prime mover speed governors are solved simultaneously (Stagg and El-Abiad [B32]).

The Laplace transform technique is useful for evaluating the dynamics of a system since easily manipulated algebraic equations are substituted for the more difficult differential equations (Dorf [B7], Edminister [B8], Hayt and Kemmerly [B17], Rainville and Bedient [B28], Scott [B29], Spiegel [B31]). The technique permits a complex system to be divided into smaller elements, each described by a *transfer function*. The transfer function of a system, or part of a system, is defined as the Laplace transform of its output variable divided by the Laplace transform of its input variable. The transfer function for each part of a system may be represented within a block of a diagram like that shown for an exciter control system in Figure 5-6. Numerous block diagram transformations are available to reduce such a diagram to a single transfer function (Dorf [B7]). For a computer program solution, however, the individual transfer functions are usually replaced by differential equations that are solved simultaneously. For example, the differential equation for the first block in Figure 5-6 can be determined as follows:

$$\frac{E_2}{E_1} = \frac{1}{1 + sT_R}$$

Cross-multiplying yields the frequency-domain equation:

$$sE_2 = \frac{1}{T_R}(E_1 - E_2)$$

Since the Laplace operator s can be treated as the differential operator d/dt , we can write the time-domain differential equation as follows:

$$\frac{dE_2}{dt} = \frac{1}{T_R}(E_1 - E_2)$$

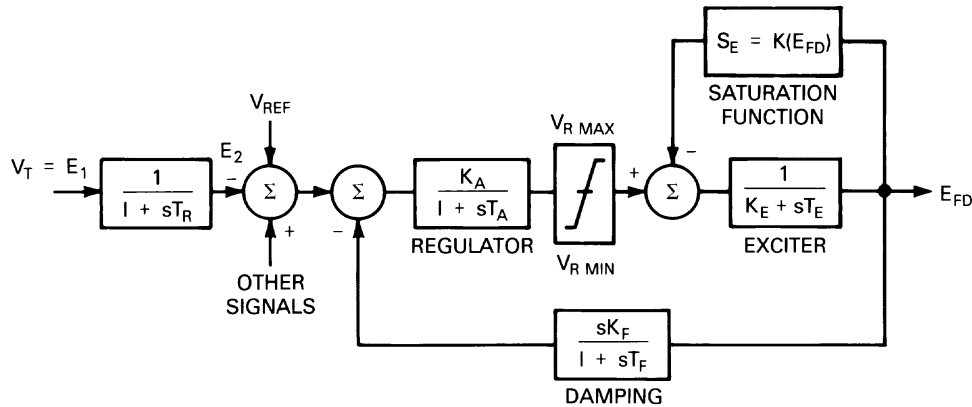

Figure 5-6—Block diagram of an exciter control system

First-order differential equations of this type can be solved at desired time increments using a mathematical approach similar to that used in the graphical development of the Newton-Raphson equation. A differential equation of order n can be represented as n first-order equations so that the methods described below can be used. For each time increment, the value of the dependent variable is determined. The calculated values approximate the smooth curve, which is the actual solution of the differential equation. For example, if we know E_1 and E_2 at time zero, we can calculate the slope (dE_2/dt) of a line tangent to the solution curve at time zero. If the time increment Δt is sufficiently small, we can assume that a point on the tangent line also falls on the solution curve. Therefore, a new value of E_2 after the first time increment can be calculated as follows:

$$E_2^1 = E_2^0 + \left. \frac{dE_2}{dt} \right|_0 \Delta t$$

This value for E_2 may be used in a similar manner to calculate a value for E_2 after the second time interval. This method for solving a differential equation is known as *Euler's method*.

Euler's method is not recommended for serious use because more accurate methods are available. The *modified Euler method* uses an iteration scheme to find the slope of the tangent line at the end of each time interval. The average slope over the time interval is used, instead of the beginning slope, to calculate each new solution. One of the most commonly used methods for the numerical solution of differential equations is the *fourth-order Runge-Kutta method*. In this method, the slope is evaluated four times during each interval: once at the initial point, twice at trial midpoints, and once at a trial end point. These four slope values are used in a special formula to calculate the average slope over the time interval without using iteration. More information on these and other methods for solving differential equations is available in several texts (see Press, Flannery, Teukolsky, and Vetterling [B26], Rainville and Bedient [B28], Stagg and El-Abiad [B32]).

5.3 Computer systems

A few of the numerical techniques used in power system analysis programs have been described in order to eliminate some of the mystery in how computers generate answers to problems too big to tackle manually. Many other aspects of computer programs, or software, should be understood before selecting or using computer techniques. The computer itself and peripheral equipment (i.e., hardware) must be considered in conjunction with software. A program is designed to be used on a particular type of computer, although alternate versions for different computers are sometimes available. Factors important in choosing the most appropriate hardware and software for power system analysis are described in this section. The improvements in computer technology continue to be rapid and dramatic. For this reason, the discussion will be kept somewhat general. Still, some of the information will probably seem antiquated in a few years.

5.3.1 Computer terminology

The following is a brief, informal glossary of terms frequently used in discussing hardware and software (Markowsky [B20], Somerson [B30], Stallings [B33]):

ASCII: A 7-bit digital code used by many computers, including most personal computers, to represent 128 alphanumeric and device control characters. ASCII stands for American Standard Code for Information Interchange. Many computers use an eighth bit to provide 128 more nonstandard special characters (e.g., graphics).

binary: A number system using only the digits 0 and 1 (also called base 2). Binary is employed in digital computers since the use of off and on to represent 0 and 1 is easily implemented in electronic circuits.

bit: An acronym for binary digit (i.e., a single 0 or 1). Usually, bit is abbreviated as lowercase b.

bug: An error in a program or a hardware flaw.

bus: In a computer, a group of conductors carrying related signals between devices. Bus width, expressed in bits (typically 8, 16, 32, or 64), affects the processing speed of a computer (wider = faster).

byte: A string of 8 bits treated as a unit. One byte is required to store one character. Usually, byte is abbreviated as uppercase B.

central processing unit (CPU): The part of a computer that fetches and executes instructions. It consists of an arithmetic and logic unit (ALU), a control unit, and a number of registers for storing data currently being processed.

copy protection: A method for preventing a program from being used on more computers than it was purchased for.

cursor: A pointer that appears on a monitor, usually to show where characters will appear as they are typed on the keyboard. In a graphical user interface (GUI) the cursor may be moved with a mouse (or other pointing device), and its shape may change when moved from a text input position to a menu selection.

default: A value or option assumed by a program when none is specified by the user.

disk (or disc): A revolving, flat, circular plate coated with magnetic material upon which data is recorded in concentric tracks. A “hard” or “fixed” disk holds large quantities of data and is permanently installed. A “floppy” disk or diskette is removable and stores a much smaller volume of data on a thin, flexible magnetic disk inside a flexible or rigid cover.

expert system: A computer application that solves problems by inference using the knowledge of human experts coded in the form of rules, logic, or cases. An expert system is a form of Artificial Intelligence (AI). Expert systems may be used in power system analysis software for data checking, case selection, and analysis of results (Mitsche [B22], Venkata, Sumic, Vadari, and Liu [B35]).

graphical user interface (GUI): typically utilizes displays with windows, dialog boxes, pull-down menus, selection boxes, diagrams, and pictures to simplify and enhance communication with a software user. The user generally operates a *mouse* to move the cursor and make selections when using a GUI (Chan [B6]).

K: In reference to data storage, used as a prefix meaning 1024 (2^{10}). For example, 2 KB (kilobytes) is 2048 bytes. If K is used alone in this context, bytes are implied.

M: In reference to data storage, used as a prefix meaning 1 048 576 (2^{20}). For example, 10 MB (megabytes) is 10 485 760 bytes. If M is used alone in this context, bytes are implied.

microprocessor: A single integrated circuit, or “chip,” which performs the functions of the central processing unit (CPU). A microprocessor is used as the main “engine” in personal computers and many other computers. Microprocessor type is a key factor determining the processing power of such computers. A related factor is the microprocessor clock speed (in megahertz [MHz]) that sets the rate at which internal functions are performed.

modem: Acronym for modulator/demodulator. Converts digital signals to analog and vice versa, so that two computers can communicate over a telephone line.

monitor: A video display (often containing a cathode ray tube [CRT]) which is used to display program output and data entered by the user on the keyboard. A wide range of types, from monochrome to high-resolution color, are available.

operating system: Software that controls the execution of other programs and the interaction with disk drives, printers, and other devices. Operating systems maybe described as single user, multitasking, or multiuser.

pel: *See:* pixel.

pixel: A picture element or dot used to make up the display on a monitor. The more pixels that a monitor displays, the higher its resolution will be. *Syn:* **pel.**

RAM: Random access memory that can be read from and written to by a user program. The amount of memory required by a program is an important factor for matching hardware to software.

ROM: Read-only memory that can only be read from. Usually, ROM contains programs that control certain basic computer functions. A program stored in ROM is called firmware (software directly implemented in hardware).

terminal: A keyboard and monitor for accessing a remote computer. Also called video display terminal (VDT), or simply cathode ray tube (CRT). A teletypewriter can also be considered a terminal.

word: The natural unit of memory in a computer consisting of a series of bits treated as a unit and stored at one memory address. The number of bits in a word generally matches the internal bus width.

5.3.2 Computer hardware

There is probably no area of technology that changes as quickly or as dramatically as that related to computer hardware. In particular, the steadily increasing power of desktop computers has changed many basic ideas about data processing. Even the categories of computer types have blurred as computers of one type begin to match, or even exceed, the capabilities associated with a more powerful category of computers (Gleason [B11], Grant, Laskowski, and Weekley [B13], Murphy [B23], Pollack [B25]). Because of these advancements, even the smallest engineering organizations can now afford some kind of genuinely useful computer equipment. In fact, the need to remain competitive pushes most companies toward expanded computer usage in all areas. The requirements of key software to be implemented should be checked carefully when selecting hardware. In addition, current computer periodicals should be reviewed for help in selecting hardware.

There may still be valid reasons, however, for not using an in-house computer for all power system studies. For example, the purchase cost for some complicated analysis programs (e.g., transient stability) may make use of a program from a computer time-sharing service more economical for infrequent studies (e.g., one per year or fewer). Even in this case, a personal computer with a modem would typically be used to access the program running on the time-sharing computer. Computer time-sharing was a big business in the early 1980s; but the availability of software and inexpensive hardware has forced many such companies to disband. Several companies, however, still offer time-sharing programs for power system analysis. Also, comprehensive studies can be performed by engineering consultants, either as part of an expansion project design contract or as a stand-alone service. Since certain studies are already required for significant expansion projects, it is a good time to request a thorough review of the plant distribution system. A stand-alone study by a consultant is justified when qualified plant engineering personnel are unavailable. Such studies are more economical if the client assists in developing the input data.

There are many available options to consider if in-house hardware is to be used for power system studies. If the prospective user is already doing other work on a computer, then obtaining suitable analysis software for the existing equipment would be a natural first approach. It's best not to jump to this conclusion, however, since analysis programs may be much more effective with a faster processor, higher resolution color monitor for graphics, and better printing/plotting equipment. Generally, hardware can be obtained either for lease or for purchase, depending on company financial considerations. Although distinctions are sometimes vague, four types of computer systems suitable for engineering applications are described below. In order of increasing cost (although there is some overlap), the categories are personal computer, engineering workstation, server, and mainframe. A fifth category, supercomputer, is not described here since these processors, the fastest and most expensive number crunchers available, are not necessary for analyzing even the largest industrial or commercial power systems. Supercomputers can be effectively applied, however, for modeling interconnected utility systems with thousands of buses.

- a) *Personal computers*, or PCs, have been available since the late 1970s. Personal computers are described as desktop computers, although some PC system units are placed on the floor next to a desk supporting a monitor and keyboard. Also, notebook-size PCs weighing only a few pounds are now available that have as much processing power as full-size units.

Until 1984, PCs were used mainly for simple, isolated tasks like word processing and spreadsheet calculations. Since then, more powerful personal computers have been introduced that can be used effectively for power system analysis. More advanced microprocessors, faster clock speeds, and math coprocessor chips (which work with the microprocessor to speed up arithmetic) have been responsible for this improvement in processing power.

As performance improves, personal computers are also being connected through local area networks (LANs) to PC file servers and larger computers to share expensive peripherals and to access common databases. PCs can also be used simply as terminals to access programs running on servers and mainframes. Advanced graphics capabilities suitable for demanding computer-aided design and drafting (CADD) are available for use with PCs. Newer operating systems have been implemented which allow a PC to perform several tasks at the same time, support a graphical user interface, and handle programs that need large amounts of memory. These improvements are bringing top-of-the-line personal computers into the same class as engineering workstations.

- b) An *engineering workstation* can be described as a high-powered, multitasking, networked, desktop computer with large memory, designed for scientific, engineering, and CADD applications. This description is essentially the same as for high-end PCs. Also, the cost of some engineering workstations is dropping into the personal computer range. Terms like "personal workstation" are being used to describe the apparent merging of the two categories.
- c) The term *server* is now generally used to describe a multiuser computer that maintains a database, manages files, or runs applications. The processing for some applications can be split between the server and a PC or workstation. PCs or workstations are the "clients" in this architecture known as client/server. The term *server* has

largely replaced the term *minicomputer*, which was first used in the 1960s to describe a class of computer that was small enough to fit into an office, yet capable of serving about five people working at terminals. The capabilities of these computers increased to support a few dozen users. When more advanced computers using 32-bit words were introduced in the late 1970s, the term *super-minicomputer* was used to distinguish them from 16-bit minicomputers.

- d) A *mainframe* is a large, general-purpose computer supporting perhaps hundreds of users, sometimes in worldwide locations. Other computers, also called mainframes, are no more powerful than large servers. Again, there is a blurring of the distinction in the categories. Mainframes and large servers are supported by an information systems staff. Usually, there is some type of intracompany accounting and billing for the use of time on these types of computers.

5.3.3 Power system analysis software

Programs for power system analysis are available for all of the computer types described in the previous section. Usually, a program for a larger computer will cost more than an equivalent program for a smaller computer. This is not unreasonable because development costs are usually more and because more people can use the one copy of the program installed on a central mainframe or server. Alternatively, a company can develop its own analysis software. In-house development was more common before a wide range of PC-based software became available. Development usually cannot be justified when a usable program is available for purchase, since, even with qualified engineering and programming personnel, development costs will probably be at least ten times the purchase cost. Available programs for power system analysis are frequently discussed and advertised in periodicals (see *Electrical Construction & Maintenance* [B9], *IEEE Computer Applications in Power* [B13], *Plant Engineering* [B27]).

A careful evaluation is always required before purchasing any kind of engineering software. A trial use period for the complete program is preferred over use of a limited demonstration disk. The following points should be considered (Oliver [B24], *Plant Engineering* [B27]):

- a) *Type of computer required.* Manufacturer, model, amount of RAM needed, graphics board and monitor, and operating system should be checked.
- b) *Program accuracy.* A description of benchmark tests to verify program results should be available. The user should also run the program for a case previously solved by another program or method.
- c) *Vendor.* The vendor should be investigated to determine length of time in business, ability to support the program, and policy on program upgrades.
- d) *Documentation.* The user's manual should be clear, concise, and thorough.
- e) *Limitations.* The program should model all items required for a particular power system including a sufficient number of buses, local generation, three-winding transformers, load tap changing transformers, industry standard adjustment factors for short-circuit currents, etc.

- f) *Ease of use.* “User friendly” programs can be operated without constant reference to the user’s manual. Programs with on-screen help provide input assistance when requested. Menu-driven programs allow selection of the desired program option from a displayed list. In many cases, a mouse may be used to select menu options and to move to desired input fields.
- g) *Input.* Full screen input on labeled screens as shown in Figure 5-7 is preferred over the 80 column input file approach of Figure 5-8. Programs that use input screens, menus, and user prompts are called *interactive* programs. *Batch* programs work using an input data file without interacting with the user during execution. Both Figure 5-7 and Figure 5-8 show data entry methods for exciter control system data like that shown in Figure 5-6. A program with a graphical user interface (GUI) might display the diagram for the exciter control system and allow input of the constants by using a mouse to select each block in the diagram. An example screen from a program with a GUI is shown in Figure 5-9. Ideally, input data is available in a common database for use by a family of analysis programs (e.g., load flow, short circuit). The input data should be easy to edit after each run in order to make changes for different design cases. Data should be validated, to the extent possible, when entered. The program should allow input in the form normally available (e.g., transformer impedance in percent on kVA base).

File: EXAMPLE1 Machine (Stability) Editor Date: MAR 30, 95

Synchronous Generator							
Machine #	Name	Bus #	Rated MVA	Rated kV	X/R	Xd"	Xd'
101	Gen. #1	1	35.300	13.800	89.50	12.800	18.600
Type	Xd	Xq"	Xq'	Xq	Xl	S100	S120
4	110.00	12.00	23.00	108.00	11.00	1.070	1.180
Tdo"	Tdo'	Tqo"	Tqo'	H	% Damp	% Bus P	% Bus Q
0.002	5.600	0.002	3.700	1.200	5.000	100.0	100.0
Exciter							
Type	VRmax	VRmin	SEmax	SE .75	Efdmax	Amax	Amin
HPC	7.500	-5.30	1.650	1.130	7.500	4.000	-3.00
Bmax	Bmin	C	D	Kpow	KQ	KE	Ctrl Bus
4.000	-1.00	40.00	0.025	0.025	0.003	1.000	3
TE	T4	TI	TD	TF	Tdsty	TP	TQ
0.510	0.020	6.800	2.000	2.000	0.005	5.000	0.011
Governor							
Type	Mode	Ki	MAX	MIN	Tem.Ctrl	Acc.Ctrl	
GTH	Isoch	4.000	1.000	-0.07	Yes	Yes	
	X	Y	Z	a	b	c	Kf
	0.000	0.050	0.000	1	0.050	1	0
	Tf	Tcr	Tcd	Ttd	T	Tt	Tr
	0.400	0.010	0.100	0.020	0.250	450.0	1000

Governor mode of operation; Droop or Isochronous - Press SPACEBAR to toggle.
 F3:Calculator F6:Dyn/Constant Z F7:Lib/Typ Data F8:Find F9:Return

Figure 5-7—Full-screen data input

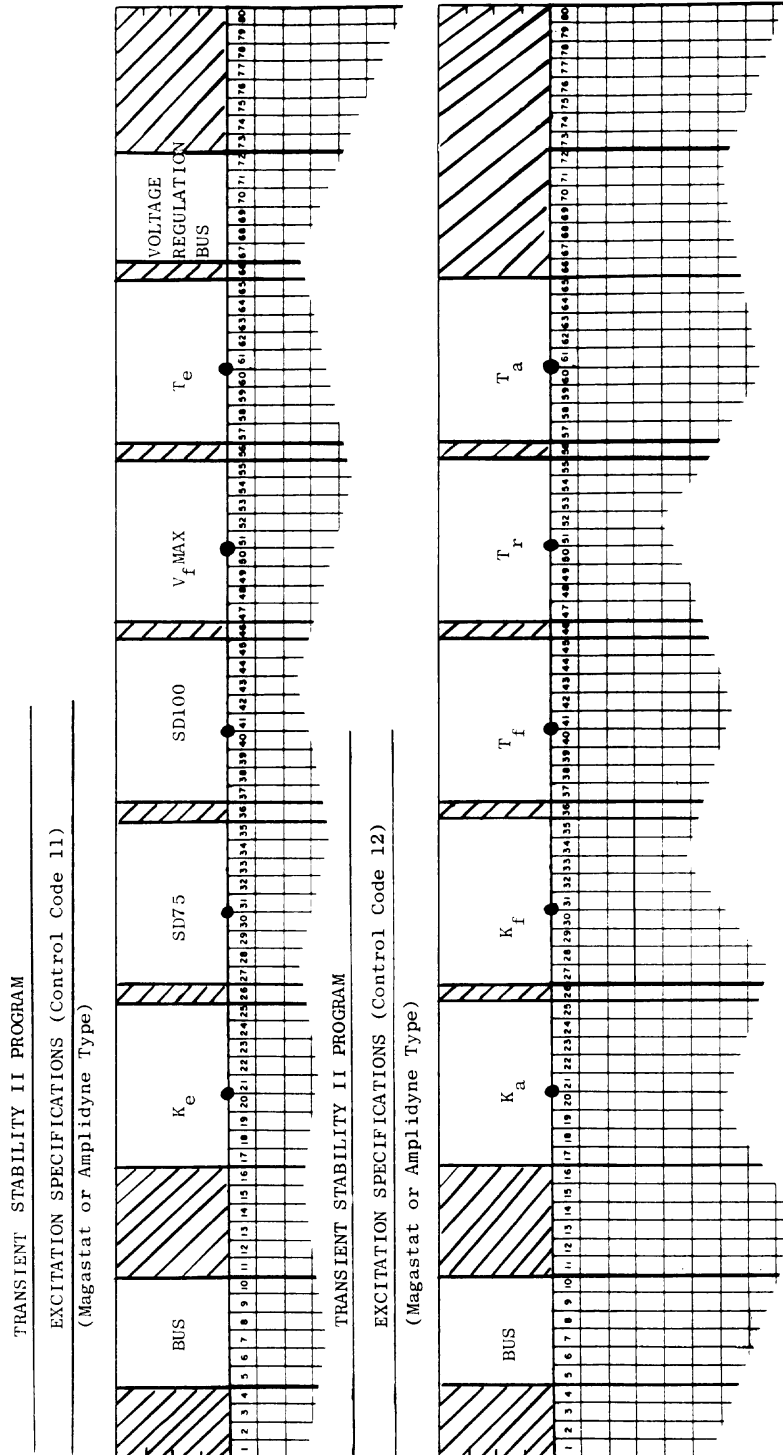

Figure 5-8—Forms for 80-column file input

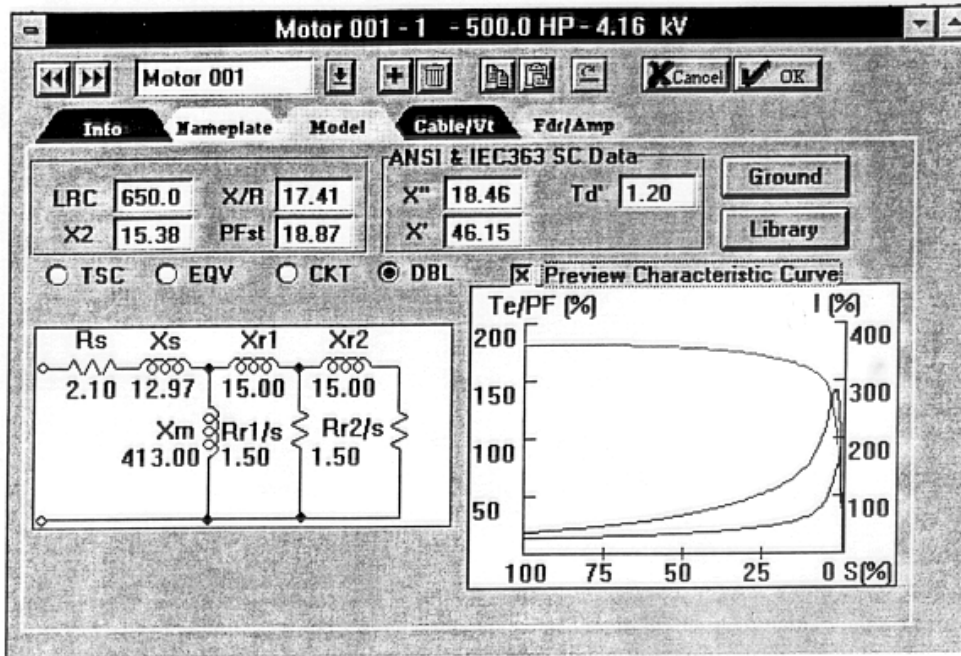

Figure 5-9—Graphical user interface (GUI)

- h) *Output.* The output report should list all input data in a readable manner so that the user can verify the basis for the run at a later date. The pages in each section of a solution report should be in a logical, visually pleasing format with appropriate titles. Some programs have the ability to plot results on the system single-line diagram.

The chapters that follow discuss many aspects of software that are specific to particular studies.

5.4 Bibliography

Additional information may be found in the following sources:

[B1] Arbenz, K., and Wohlhauser, A., *Advanced Mathematics for Practicing Engineers*, Norwood, MA: Artech House, 1986.

[B2] Arrillaga, J., Arnold, C. P., and Harker, B. J., *Computer Modeling of Electrical Power Systems*, New York: John Wiley & Sons, 1983.

[B3] Brown, H. E., Person, C. E., Kirchmayer, L. K., and Stagg, G. W., "Digital calculation of three-phase short circuits by matrix method," *Transactions of the AIEE*, vol. 79, pt. III, pp. 1277–1281, 1960.

- [B4] Buchanan, J. L., and Turner, P. R., *Numerical Methods and Analysis*, New York: McGraw-Hill, 1992.
- [B5] Burden, R. L., and Faires, J. D., *Numerical Analysis*, Boston: Prindle, Weber & Schmidt, 1985.
- [B6] Chan, S., "Interactive Graphics Interface for Power System Network Analysis," *IEEE Computer Applications in Power*, IEEE Power Engineering Society, Jan. 1990, pp. 34–38.
- [B7] Dorf, R. C., *Modern Control Systems*, Reading, MA: Addison-Wesley, 1974.
- [B8] Edminister, J. A., *Theory and Problems of Electric Circuits*, Schaum's Outline Series, New York: McGraw-Hill, 1965.
- [B9] *Electrical Construction & Maintenance*, New York, McGraw-Hill (monthly).
- [B10] Gerald, C. F., and Wheatley, P. O., *Applied Numerical Analysis*, Reading, MA: Addison-Wesley, 1984.
- [B11] Gleason, B., "A New Culture—32-bit Technology on Your Desk," *Computer*, IEEE Computer Society, July 1988, pp. 74–76.
- [B12] Gonen, T., *Modern Power System Analysis*, New York: John Wiley & Sons, 1988.
- [B13] Grant, I. S., Laskowski, T. F., and Weekley, A. R., "Small computer capabilities vs. large power-planning program requirements," *IEEE Computer Applications in Power*, IEEE Power Engineering Society, Jan. 1988, pp. 34–36.
- [B14] Grove, W. E., *Brief Numerical Methods*, Englewood Cliffs, NJ: Prentice-Hall, 1966.
- [B15] Groza, V. S., and Shelley, S., *Precalculus Mathematics*, New York: Holt, Rinehart and Winston, 1972.
- [B16] Hashemi, N., Love, D. J., and Tajaddodi, F. Y., "A Relational Database Approach to Design of Power Plant and Large Industrial Electrical Facilities," 1987 I & CPS Conference Paper ICPSD-87-01, presented in Nashville, TN, May 5, 1987.
- [B17] Hayt, Jr., W. H., and Kemmerly, J. E., *Engineering Circuit Analysis*, New York: McGraw-Hill, 1978.
- [B18] Heydt, G. T., *Computer Analysis Methods for Power Systems*, New York: Macmillan, 1986.
- [B19] Kusic, G. L., *Computer Aided Power System Analysis*, Englewood Cliffs, NJ: Prentice-Hall, 1986.

- [B20] Markowsky, G., *A Comprehensive Guide to the IBM Personal Computer*, Englewood Cliffs, NJ: Prentice-Hall, 1984.
- [B21] Maron, W. J., *Numerical Analysis*, New York: Macmillan, 1987.
- [B22] Mitsche, J. V., "Stretching the Limits of Power System Analysis," *IEEE Computer Applications in Power*, IEEE Power Engineering Society, Jan. 1993, pp. 16–21.
- [B23] Murphy, E. E., "Minisuper, Supermini: What's in an Adjective?," *IEEE Spectrum*, May 1989, p. 22.
- [B24] Oliver, W. K., "Evaluating CAE Software," *Hydrocarbon Processing*, Feb. 1985.
- [B25] Pollack, A., "Sun, Apple on Collision Course," *Houston Chronicle*, Mar. 12, 1989.
- [B26] Press, W. H., Flannery, B. P., Teukolsky, S. A., and Vetterling, W. T., *Numerical Recipes in C*, Cambridge, England: Cambridge University Press, 1988.
- [B27] "Problem Solving Software," *Plant Engineering*, Cahners, June 9, 1988, pp. 62–102.
- [B28] Rainville, E. D., and Bedient, P. E., *Elementary Differential Equations*, New York: Macmillan, 1974.
- [B29] Scott, R. E., *Elements of Linear Circuits*, Reading, MA: Addison-Wesley, 1965.
- [B30] Somerson, P., *PC Magazine DOS Power Tools*, New York: Bantam Books, 1988.
- [B31] Spiegel, M. R., *Theory and Problems of Advanced Mathematics for Engineers and Scientists*, Schaum's Outline Series, New York: McGraw-Hill, 1971.
- [B32] Stagg, G. W., and El-Abiad, A. H., *Computer Methods in Power System Analysis*, New York: McGraw-Hill, 1968.
- [B33] Stallings, W., *Computer Organization and Architecture*, New York: Macmillan, 1987.
- [B34] Stevenson, Jr., W. D., *Elements of Power System Analysis*, New York: McGraw-Hill, 1982.
- [B35] Venkata S., Sumic, Z., Vadari, S., and Liu, C., "Applying AI systems in the T&D arena," *IEEE Computer Applications in Power*, IEEE Power Engineering Society, April 1993, pp. 29–34.
- [B36] Wallach, Y., *Calculations and Programs for Power System Networks*, Englewood Cliffs, NJ: Prentice-Hall, 1986.

Chapter 6

Load flow studies

6.1 Introduction

One of the most common computational procedures used in power system analysis is the load flow calculation. The planning, design, and operation of power systems require such calculations to analyze the steady-state (quiescent) performance of the power system under various operating conditions and to study the effects of changes in equipment configuration. These load flow solutions are performed using computer programs designed specifically for this purpose. The basic load flow question is this: Given the load power consumption at all buses of a known electric power system configuration and the power production at each generator, find the power flow in each line and transformer of the interconnecting network and the voltage magnitude and phase angle at each bus.

Analyzing the solution of this problem for numerous conditions helps ensure that the power system is designed to satisfy its performance criteria while incurring the most favorable investment and operation costs.

Some examples of the uses of load flow studies are to determine the following:

- Component or circuit loadings
- Steady-state bus voltages
- Reactive power flows
- Transformer tap settings
- System losses
- Generator exciter/regulator voltage set points
- Performance under emergency conditions

Modern systems are complex and have many paths or branches over which power can flow. Such systems form networks of series and parallel paths. Electric power flow in these networks divides among the branches until a balance is reached in accordance with Kirchoff's laws.

Computer programs to solve load flows are divided into two types—static (offline) and dynamic (real time). Most load flow studies for system analysis are based on static network models. Real time load flows (online) that incorporate data input from the actual networks are typically used by utilities in automatic Supervisory Control And Data Acquisition (SCADA) systems. Such systems are used primarily as operating tools for optimization of generation, var control, dispatch, losses, and tie line control. This discussion is concerned with only static network models and their analysis.

Because the load flow problem pertains to balanced, steady-state operation of power systems, a single-phase, positive sequence model of the power system is used. Three-phase load flow

analysis software is available; but it is not normally needed for routine industrial power system studies.

A load flow calculation determines the state of the power system for a given load and generation distribution. It represents a steady-state condition as if that condition had been held fixed for some time. In actuality, line flows and bus voltages fluctuate constantly by small amounts because loads change constantly as lights, motors, and other loads are turned on and off. However, these small fluctuations can be ignored in calculating the steady-state effects on system equipment.

As the load distribution, and possibly the network, will vary considerably during different time periods, it may be necessary to obtain load flow solutions representing different system conditions such as peak load, average load, or light load. These solutions will be used to determine either optimum operating modes for normal conditions, such as the proper setting of voltage control devices, or how the system will respond to abnormal conditions, such as outages of lines or transformers. Load flows form the basis for determining both when new equipment additions are needed and the effectiveness of new alternatives to solve present deficiencies and meet future system requirements.

The load flow model is also the basis for several other types of studies such as short-circuit, stability, motor starting, and harmonic studies. The load flow model supplies the network data and an initial steady-state condition for these studies.

6.2 System representation

Utility and industrial plant electrical systems can be extensive. A simplified visual means of representing the complete system is essential to understanding the operation of the system under its various possible operating modes. The system single-line diagram serves this purpose. The single-line diagram consists of a drawing identifying buses and interconnecting lines. Loads, generators, transformers, reactors, capacitors, etc., are all shown in their respective places in the system. It is necessary to show equipment parameters as well as their relationship to each other. Figure 6-1 is a single-line diagram of the sample industrial plant system that will be used later to illustrate some aspects of load flow studies. It shows the operating condition to be studied in terms of which breakers are open or closed.

Buses may be named, numbered, or both. Interconnecting lines are usually shown with their impedance values entered or cross-referenced with tables of values. Equipment associated with a bus is shown connected to that bus. For instance, generators are shown connected to their bus with their equipment parameters specified, as illustrated in Figure 6-2. Similarly, a load is shown connected to bus 49 in Figure 6-3. Motor loads are often indicated separately to aid in their modeling in short circuit and other studies. Each line originates on a bus and terminates on a different bus, as depicted in Figure 6-3. For example, a line runs from bus 3 (MILL-1) to bus 5 (FDR F) and is shown to be 325 ft long, 3 conductor, 250 kcmil cable.

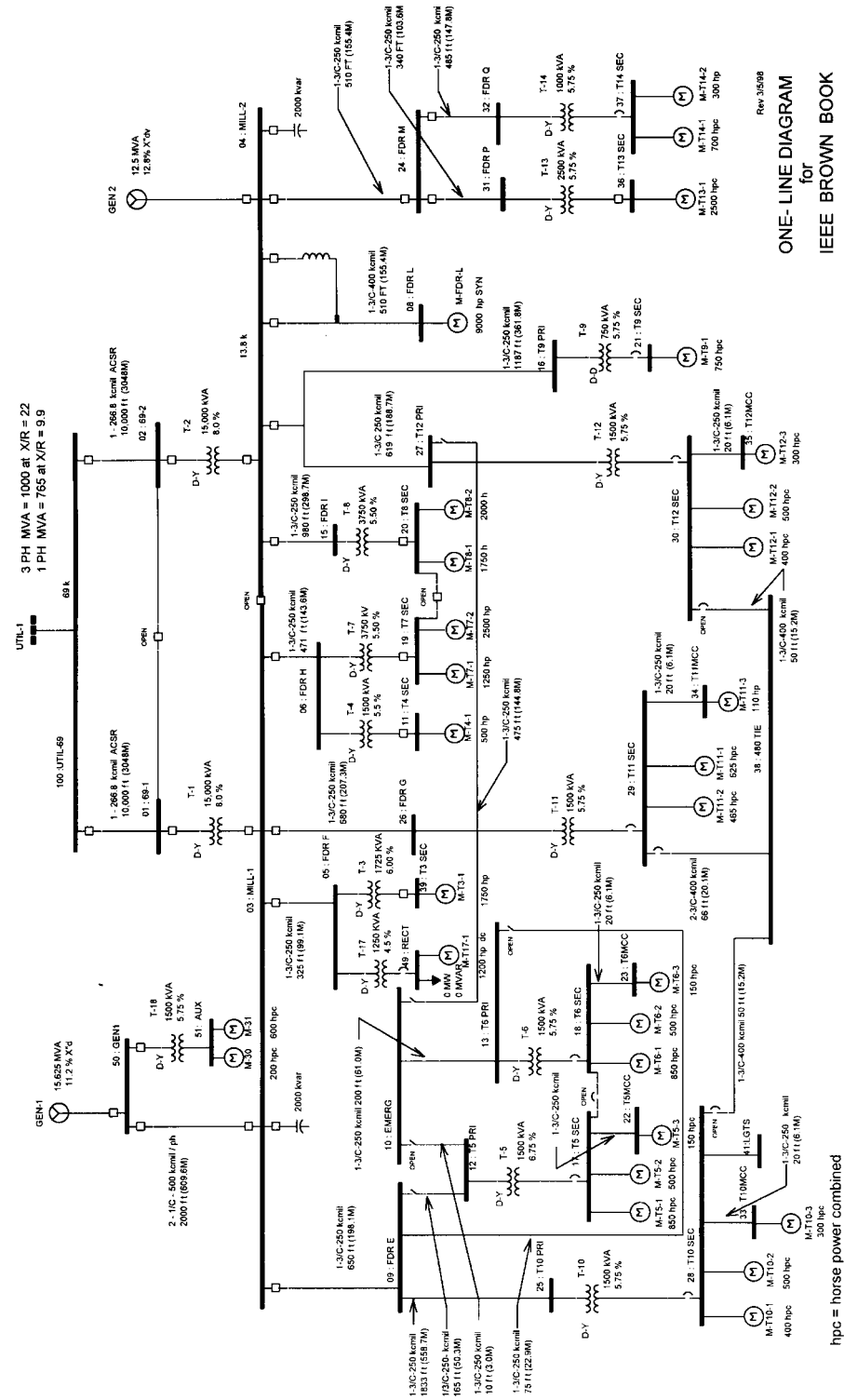

Figure 6-1—Single-line diagram of typical industrial power system for load flow study example

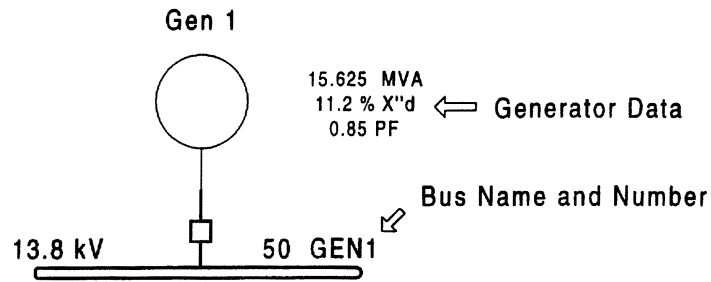

Figure 6-2—Bus and generator representation

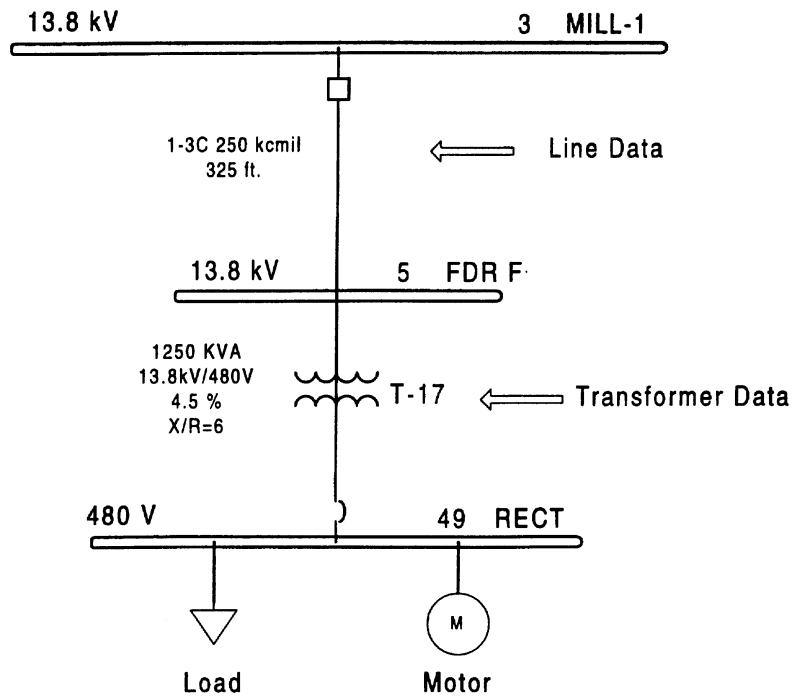

Figure 6-3—Representation of loads, lines, and transformers

Transformers, like lines, are shown between two buses with the primary connected to one bus and the secondary to the other. Information to convey an off-nominal turns ratio should be given when applicable.

Drawing format will vary depending on the computer programs used and the preference of the users, but the single-line diagram should give the necessary network information in a clear, concise manner. The transfer of this data to the load flow program for analysis is discussed in the next section.

6.3 Input data

The system information, shown on the single-line diagram, defines the system configuration and the location and size of loads, generation, and equipment. It is organized into a list of data that defines the mathematical model for each power system component and how the components are connected together. The preparation of this data file is the foundation of all load flow analysis, as well as other analysis requiring the network model, such as short-circuit and stability analysis. It is therefore essential that the data preparation be performed in a consistent, thorough manner. Data values must be as accurate as possible. Rounding off, or not including enough decimal places in certain parameters, can lead to erroneous results. Influential parameters must not be ignored.

The details of the models of the system components are addressed in Chapter 4. In this subclause, data organization is shown in general terms and some comments are given on data preparation. The data is divided into the following categories, as this organization is typical of most load flow analysis software: system data, bus data, generator data, branch data, and transformer data. In order to illustrate the approach required when using a typical program, the details of one such system will be described.

6.3.1 System data

As noted in Chapter 4, most load flow programs perform their calculations using a per unit representation of the system rather than working with volts, amperes, and ohms. The input of data to the program may either be in per unit or in physical units, depending on program convention. Converting the system data to a per unit representation requires the selection of a base kVA and base voltage. Selection of the base kVA and base voltage specifies the base impedance and current.

The system data specifies the base kVA (or MVA) for the entire system. A base kVA of 10 000 kVA (10 MVA) is often used for industrial studies. For utility systems, the accepted convention is a base of 100 MVA.

The base kV is chosen for each voltage level. Selecting the nominal voltage to be the base voltage simplifies the analyses and reduces the chance of errors in interpretation of results.

6.3.2 Bus data

The bus data describes each bus and the load and shunts connected to that bus. The data includes the following:

- Bus number
- Bus name
- Bus type
- Load
- Shunt
- Per unit voltage and angle
- Bus base kV

The bus number is normally the primary index to the information about the bus. For example, it is used to define the line connections in the line data and will be used to get output about a bus during program execution. The bus name is normally used only for informational purposes, allowing the user to give a descriptive name to the bus to make program output more easily understood. Some programs allow the use of the bus name as the primary index.

The bus type is a program code to allow the program to properly organize the buses for load flow solution. This organization varies among programs and may be handled internally by the program. Typically, the four bus types are as follows:

- a) Load buses
- b) Generator buses
- c) Swing buses
- d) Disconnected buses

The terms “load” bus and “generator” bus should not be taken literally. A load bus is any bus that does not have a generator. A load bus need not have load; it may simply be an interconnection point for two or more lines. A generator bus could also have load connected to it. The “swing” or “slack” bus is a special type of generator bus that is needed by the solution process. The swing generator adjusts its scheduled power to supply the system MW and Mvar losses that are not otherwise accounted for. This is explained in more detail in the section on load flow solution. There is normally only one swing bus. In utility studies, a large generator is picked as the swing bus. In industrial studies, the utility supply is usually represented as the swing bus. A “disconnected” bus is a bus that is temporarily deenergized. It is not included in the load flow solution and must not have in-service lines connected to it. The data is retained so the bus could be reenergized (connected to the system) later in the studies.

Load is normally entered in MW and Mvar at nominal voltage. Normally, the load is treated as a constant MVA, that is, independent of voltage. In some cases, a constant current or constant impedance component of load will also be entered so that the load is a function of voltage as explained in 4.9. Shunts generally are entered in Mvar at nominal voltage. Care must be taken to ensure the proper sign convention is used to distinguish reactors from capacitors as defined for the particular load flow program being used.

The bus base kV is often entered to allow output reports to show voltages in kV and currents in amperes.

6.3.3 Generator data

Generator data is entered for each generator in the system including the system swing generator. The data defines the generator power output and how voltage is controlled by the generator. The data items normally entered are as follows:

- Real power output in MW
- Maximum reactive power output in Mvar (i.e., machine maximum reactive limit)
- Minimum reactive power output in Mvar (i.e., machine minimum reactive limit)
- Scheduled voltage in per unit
- Generator in-service/out-of-service code

Other data items that may be included are the generator MVA base and the generator's internal impedance for use in short-circuit and dynamic studies. The use of the above data items to determine the generator voltage and reactive power output is discussed in 6.4. Some programs may allow a generator to regulate a remote bus voltage.

6.3.4 Branch data

Data is also entered for each branch in the system. Here the term “branch” refers to all elements that connect two buses including transmission lines, cables, series reactors, series capacitors, and transformers. The data items include the following:

- Resistance
- Reactance
- Charging susceptance (shunt capacitance)
- Line ratings
- Line in-service/out-of-service code
- Line-connected shunts

As described in 4.7, lines are represented by a π model with series resistance and reactance and one-half of the charging susceptance placed on each end of the line. The resistance, reactance, and susceptance are usually input in either per unit or percent, depending on program convention.

Line ratings are normally input in amperes or MVA. Current ratings can be converted to MVA with the formula:

$$\text{rating}_{\text{MVA}} = \frac{\sqrt{3} \times \text{kV}_{\text{BASE}} \times \text{rating}_{\text{A}}}{1000} \quad (6-1)$$

A series reactor, series capacitor, or transformer would not have a charging susceptance term.

The modeling of the charging susceptance is often ignored for short overhead lines and industrial plant systems.

6.3.5 Transformer data

Additional data is required for transformers. This can either be entered as part of the branch data or as a separate data category depending on the particular load flow program being used. This additional data usually includes the following:

- Tap setting in per unit
- Tap angle in degrees
- Maximum tap position
- Minimum tap position
- Scheduled voltage range with tap step size or a fixed scheduled voltage using a continuous tap approximation

The last three data items are needed only for load tap changing (LTC) transformers that automatically vary their tap setting to control voltage on one side of the transformer.

The organization of transformer tap data requires an understanding of the tap convention used by the load flow program to ensure the representation gives the correct boost or buck in voltage. Transformers whose rated primary or secondary voltages do not match the system nominal (base kV) voltages on the terminal buses will require an off-nominal tap representation in the load flow (and possibly require corresponding adjustment of the transformer impedance).

6.4 Load flow solution methods

The computational task of determining power flows and voltages for even a small network for a given system condition is formidable. Solution of large networks for many system conditions as required for analysis of present-day power systems requires sophisticated computational tools.

The first load flow solution device was a special purpose analog computer called the ac network analyzer developed in the late 1920s. Power system networks under study were represented by an equivalent, scaled-down network. The device allowed the analysis of a variety of operating conditions and expansion plans. However, setup time was long. Due to the large amount of hardware involved, only about 50 network analyzers were operational by the mid-1950s.

Digital computers began to emerge in the late 1940s as computational tools. By the mid-1950s, large-scale digital computers of sufficient speed and size to handle the requirements of a power system network calculation were available. Parallel to the hardware development, algorithms to efficiently solve the network equations were developed. Ward and Hale developed a successful load flow program using a modified Newton iterative procedure in

1956 [B5].¹ The application of the Gauss-Seidel iteration algorithm followed soon after. Research in algorithms continued and the Newton-Raphson method was introduced in the early 1960s [B4]. Considerable research has been performed in the interim years to improve the performance of these algorithms, making them more robust, able to handle additional power system components, and allowing much larger network sizes.

6.4.1 Problem formulation

The load flow calculation is a network solution problem. The voltages and currents are related by the following equation:

$$[I] = [Y][V] \quad (6-2)$$

where

- [I] is the vector of total positive sequence currents flowing into the network nodes (buses)
- [V] is the vector of positive sequence voltages at the network nodes (buses)
- [Y] is the network admittance matrix

Equation (6-2) is a linear algebraic equation with complex coefficients. If either [I] or [V] were known, the solution for the unknown quantities could be obtained by application of widely used numerical solution techniques for linear equations.

Partly because of tradition and partly because of the physical characteristics of generation and load, the terminal conditions at each bus are normally described in terms of active and reactive power (P and Q). The bus current at bus i is related to these quantities as follows:

$$I_i = \frac{(P_i + jQ_i)^*}{V_i^*} \quad (6-3)$$

where * designates the conjugate of a complex quantity. Combining Equations (6-2) and (6-3) yields

$$\left[\frac{P - jQ}{V^*} \right] = [Y][V] \quad (6-4)$$

Equation (6-4) is nonlinear and cannot be readily solved by closed-form matrix techniques. Because of this, load flow solutions are obtained by procedures involving iterative techniques.

6.4.2 Iterative solution algorithms

Since the original technical papers describing digital load flow solution algorithms appeared in the mid-1950s, a seemingly endless collection of iterative schemes has been developed and

¹ The numbers in brackets preceded by the letter B correspond to those of the bibliography in 6.10.

reported. Many of these are variations of one or the other of two basic techniques that are in widespread use by the industry today: the Gauss-Seidel technique and the Newton-Raphson technique. The preferred techniques used by most commercial load flow software are variations of the Newton technique.

All of these techniques solve bus equations in admittance form, as described in the previous section. This system of equations has gained widespread application because of the simplicity of data preparation and the ease with which the bus admittance matrix can be formed and changed in subsequent cases.

In a load flow study, the primary parameters are as follows:

- P is the active power into the network
- Q is the reactive power into the network
- $|V|$ is the magnitude of bus voltage
- δ is the angle of bus voltage referred to a common reference

In order to define the load flow problem to be solved, it is necessary to specify two of the four quantities at each bus. For generating units, it is reasonable to specify P and $|V|$ because these quantities are controllable through governor and excitation controls, respectively. For loads, one generally specifies the real power demand P and the reactive power Q . Since there are losses in the transmission system and these losses are not known before the load flow solution is obtained, it is necessary to retain one bus where P is not specified. At this bus, called a swing bus, $|V|$ as well as δ are specified. Since δ is specified (that is, held constant during the load flow solution), it is the reference angle for the system. The swing bus is therefore also called the reference bus. Since the real power, P , and reactive power, Q , are not specified at the swing bus, they are free to adjust to “cover” transmission losses in the system.

Table 6-1 summarizes the standard electrical specifications for the three bus types. The classifications “generator bus” and “load bus” should not be taken as absolute. There will, for example, be occasions where a pure load bus may be specified by P and $|V|$.

Bus specification is the tool with which the engineer manipulates the load flow solution to obtain the desired information. The objective of the load flow solution is to determine the two quantities at each bus that are not specified.

The generator specification of holding the bus voltage constant and calculating the reactive power output will be overridden in the load flow solution if the generator reactive output reaches its maximum or minimum var limit. In this case, the generator reactive power will be held at the respective limit, and the bus voltage will be allowed to vary.

6.4.3 Gauss-Seidel iterative technique

Descriptions of load flow solution techniques can become rather complicated, due more to the notation required for complex arithmetic rather than the basic concepts of the solution method. In the following sections, therefore, the basic techniques are developed by

Table 6-1— Load flow bus specifications

Bus type	P	Q	$ V $	δ	Comments
Load	✓	✓			Usual load representation
Generator or synchronous condenser	✓		✓ when $Q^- < Q_g < Q^+$		Generator or synchronous condenser ($P=0$) with var limits Q^- = minimum var limit Q^+ = maximum var limit
	✓	✓ when $Q_g < Q^-$ or $Q_g > Q^+$			$ V $ is held as long as Q_g is within limit
Swing			✓	✓	“Swing bus” must adjust net power to hold voltage constant (essential for solution).
NOTES 1—Quantities checked are the bus boundary conditions. 2— $[P, \delta]$, $[Q, V]$, and $[Q, \delta]$ combinations are generally not used.					

considering their application to a dc circuit. Applications to ac problems are then a natural extension of the dc problem.

The Gauss-Seidel solution algorithm, although not the most powerful, is the easiest to understand. The performance of the Gauss-Seidel technique will be illustrated using the direct current circuit shown in Figure 6-4.

Bus 3 is a load bus with specified per unit power. Bus 2 is a generator bus with power specified, and bus 1 is the swing bus with voltage specified. The voltages V_2 and V_3 are sought. From these, the branch flows can be calculated.

The system equations on an admittance basis are from Equation (6-2).

$$\begin{bmatrix} I_1 \\ I_2 \\ I_3 \end{bmatrix} = \begin{bmatrix} Y_{11} & Y_{12} & Y_{13} \\ Y_{21} & Y_{22} & Y_{23} \\ Y_{31} & Y_{32} & Y_{33} \end{bmatrix} \begin{bmatrix} V_1 \\ V_2 \\ V_3 \end{bmatrix} \quad (6-5)$$

The terms of the admittance matrix are easily determined from the circuit [2], [3], [4], [7]. The off-diagonal term Y_{ij} is the negative of the line admittance between bus i and bus j .

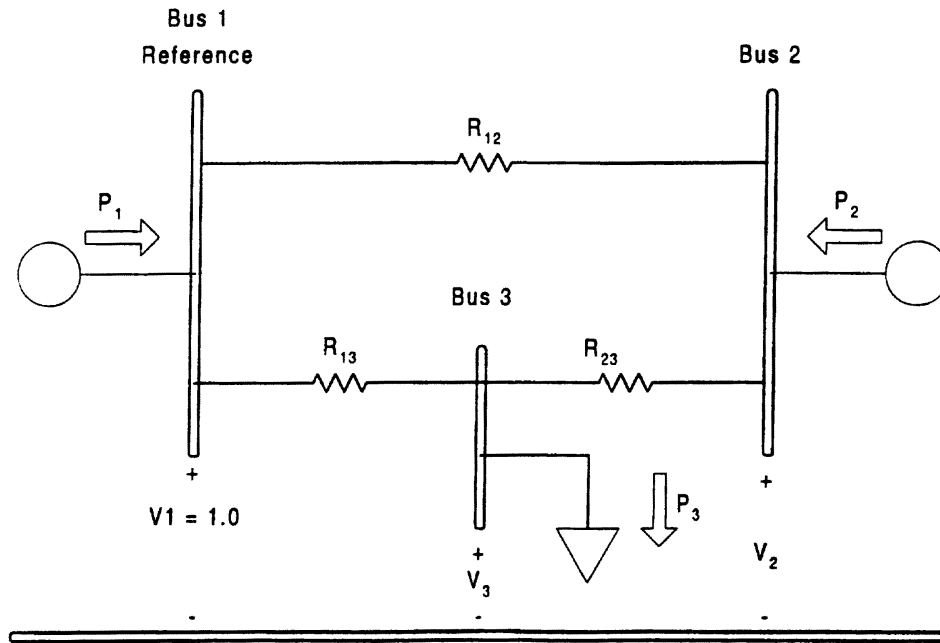

Figure 6-4—Three-bus dc network

$$Y_{ij} = \frac{-1}{Z_{ij}} \quad (6-6)$$

The diagonal terms are the sum of the admittances of the lines leaving a bus plus the admittance of the bus shunt plus one-half of the charging admittance for each connected line. The Y matrix is very sparse (few nonzero elements), so special matrix techniques are often used to minimize computer storage requirements. From Equation (6-5),

$$I_2 = Y_{21}V_1 + Y_{22}V_2 + Y_{23}V_3 \quad (6-7)$$

or

$$V_2 = \frac{1}{Y_{22}}[I_2 - (Y_{21}V_1 + Y_{23}V_3)] \quad (6-8)$$

Substituting

$$I_2 = P_2/V_2 \quad (6-9)$$

$$V_2 = \frac{1}{Y_{22}} \left[\frac{P_2}{V_2} - (Y_{21}V_1 + Y_{23}V_3) \right] \quad (6-10)$$

This is a nonlinear equation in V_2 .

For bus 3, a similar procedure yields

$$V_3 = \frac{1}{Y_{33}} \left[\frac{-P_3}{V_3} - (Y_{31}V_1 + Y_{32}V_2) \right] \quad (6-11)$$

where the negative sign on P_3 is from the load sign convention.

Equations (6-10) and (6-11) are in a form convenient for the application of the Gauss-Seidel iterative solution technique. The steps in this procedure are as follows:

- a) Step 1: Assign an estimate of V_2 and V_3 (for example, $V_2 = V_3 = 1.0$). Note that V_1 is fixed.
- b) Step 2: Compute a new value for V_2 using the initial estimates for V_2 and V_3 [see Equation (6-10)].
- c) Step 3: Compute a new value for V_3 using the initial estimate for V_3 and the just computed value for V_2 [see Equation (6-11)].
- d) Step 4: Repeat b) and c) using the latest computed voltages V_2 and V_3 until the solution is reached. One complete computation of V_2 and V_3 is one iteration.

The computed voltages are said to converge when, for each iteration, they come closer and closer to the actual solution satisfying the network equations. Since the computer time increases linearly with the number of iterations, it is necessary to have the computer program make a check after each iteration and decide whether the last computed voltages are sufficiently close to the true solution or whether further computations are required. The criterion specifying the desired accuracy is called the “convergence criterion.”

A reliable convergence criterion is the power mismatch check. Based on the last computed voltage solution, the sum of the power flows (real and reactive) on all lines connected to the bus and to the bus shunt is compared with the specified bus real and reactive power. The difference, which is the power mismatch, is a measure of how close the computed voltages are to the true solution. The power mismatch tolerance is generally specified in the range of 0.01 to 0.0001 p.u. on the system MVA base.

A different convergence check evaluates the maximum change in any bus voltage from one iteration to the next. A solution with desired accuracy is assumed when the change is less than a specified small value, for example, 0.0001 p.u.

A voltage check is dependent on the rate of convergence and is thus less reliable than the power mismatch check. However, the voltage check is much faster (computationally, on a digital computer) than the power mismatch check and since the power mismatch will be large

until the voltage change is quite small, one may economically use a procedure where computation of mismatch is avoided until a small amount of voltage change occurs.

While the solution for a dc circuit was described, solution of an ac circuit would be very similar. For the three-bus example, voltage magnitude and angle at bus 1, generator power and bus voltage at bus 2, and real and reactive load power at bus 3 would be specified. The load flow solution would determine the voltage angle and generator reactive power output of bus 2 and the voltage magnitude and angle at bus 3.

The ac version of Equations (6-9) and (6-10) can be obtained from Equation (6-4) as follows:

$$V_i^{(m)} = \frac{1}{Y_{ii}} \left(\frac{P_i - jQ_i}{V_i^{*(m-1)}} - \sum_{k=1}^{i-1} Y_{ik} V_k^{(m)} - \sum_{k=i+1}^N Y_{ik} V_k^{(m-1)} \right) \quad i = 1, 2, \dots, N-1 \quad (6-12)$$

where

- N is the number of buses in the system, and the swing bus is bus N
- m is the present iteration number
- i and k are bus indexes
- V and Y are complex voltage and admittance, respectively
- V^* is the complex conjugate of V

6.4.4 Newton-Raphson iterative technique

Not all load flow problems can be solved efficiently using the Gauss-Seidel technique. For some problems, this scheme converges rather slowly. For others, it does not converge at all. Problems that cannot be solved using the Gauss-Seidel technique may often be solved using the Newton-Raphson technique.

This approach utilizes the partial derivatives of the load flow relationships to estimate the changes in the independent variables required to find the solution. In general, the Newton-Raphson technique achieves convergence using fewer iterations than the Gauss-Seidel technique. However, the computational effort per iteration is somewhat greater.

To apply the Newton-Raphson technique to the three-bus example in Figure 6-4, the bus powers are expressed as nonlinear functions of the bus voltage.

$$\begin{aligned} P_1 &= V_1(Y_{11}V_1 + Y_{12}V_2 + Y_{13}V_3) \\ P_2 &= V_2(Y_{21}V_1 + Y_{22}V_2 + Y_{23}V_3) \\ P_3 &= V_3(Y_{31}V_1 + Y_{32}V_2 + Y_{33}V_3) \end{aligned} \quad (6-13)$$

Small changes in bus voltages (ΔV) will cause corresponding, small changes in bus powers (ΔP). A linearized approximation to the power change as a function of voltage changes can be obtained as follows:

$$\begin{bmatrix} \Delta P_1 \\ \Delta P_2 \\ \Delta P_3 \end{bmatrix} = \begin{bmatrix} \frac{\partial P_1}{\partial V_1} & \frac{\partial P_1}{\partial V_2} & \frac{\partial P_1}{\partial V_3} \\ \frac{\partial P_2}{\partial V_1} & \frac{\partial P_2}{\partial V_2} & \frac{\partial P_2}{\partial V_3} \\ \frac{\partial P_3}{\partial V_1} & \frac{\partial P_3}{\partial V_2} & \frac{\partial P_3}{\partial V_3} \end{bmatrix} \begin{bmatrix} \Delta V_1 \\ \Delta V_2 \\ \Delta V_3 \end{bmatrix} \quad (6-14)$$

or symbolically:

$$[\Delta P] = [J] [\Delta V]$$

where $[J]$, the Jacobian matrix, contains the partial derivatives of power with respect to voltages for a particular set of voltages, V_1 , V_2 , and V_3 , that is, the partial derivations of Equation (6-13). When one or more of the voltages changes substantially, a new Jacobian matrix must be computed.

In the load flow problem, V_1 is specified; that is, $\Delta V_1 = 0$. Also, since ΔP_1 does not enter the computations explicitly, Equation (6-14) may be reduced to

$$\begin{bmatrix} \Delta P_2 \\ \Delta P_3 \end{bmatrix} = \begin{bmatrix} \frac{\partial P_2}{\partial V_2} & \frac{\partial P_2}{\partial V_3} \\ \frac{\partial P_3}{\partial V_2} & \frac{\partial P_3}{\partial V_3} \end{bmatrix} \begin{bmatrix} \Delta V_2 \\ \Delta V_3 \end{bmatrix} \quad (6-15)$$

Changes in V_2 and V_3 due to changes in P_2 and P_3 are obtained by inverting $[J]$ to obtain

$$[\Delta V] = [J]^{-1} [\Delta P] \quad (6-16)$$

The Newton-Raphson load flow solution method is then as follows:

- a) Step 1: Assign estimates of V_2 and V_3 (for example, $V_2 = V_3 = 1.0$).
- b) Step 2: Compute P_2 and P_3 from Equation (6-13).
- c) Step 3: Compute the differences (ΔP) between computed and specified powers:

$$\begin{aligned} \Delta P_2 &= P_2 - P'_2 \\ \Delta P_3 &= P_3 - P'_3 \end{aligned} \quad (6-17)$$

where the "prime" indicates specified value.

- d) Step 4: Since $\Delta P \neq 0$ is caused by errors in the voltages, it seems that the voltages should be incorrect by an amount that is closely approximated by ΔV as evaluated from Equation (6-16).

Therefore, the new estimate for the bus voltages is

$$\begin{bmatrix} V_2 \\ V_3 \end{bmatrix}_{\text{new}} = \begin{bmatrix} V_2 \\ V_3 \end{bmatrix}_{\text{old}} - [J]^{-1} \begin{bmatrix} \Delta P_2 \\ \Delta P_3 \end{bmatrix} \quad (6-18)$$

This is the basic equation in the Newton-Raphson method. The negative sign is due to the way ΔP was defined.

- e) Step 5: Recompute and “invert” the Jacobian matrix using the last computed voltages and compute the new estimate for the voltages using Equations (6-17) and (6-18). Repeat this procedure until ΔP_2 and ΔP_3 are less than a small value (convergence criterion).

Digital computer programs solving large power system load flows do not explicitly compute the Jacobian inverse. Rather, the voltage correction ΔV is obtained by a numerical technique known as Gaussian elimination. This technique is much faster and requires much less storage than matrix inversion.

The convergence of the Newton-Raphson technique is not asymptotic as was the case with the Gauss-Seidel iterative scheme. The convergence is very rapid for the first few iterations and slows as the solution is neared.

For the ac load flow solution, the Jacobian matrix may be arranged as follows:

$$\begin{bmatrix} \Delta P \\ \Delta Q \end{bmatrix} = \begin{bmatrix} J_1 & J_2 \\ J_3 & J_4 \end{bmatrix} \begin{bmatrix} \Delta \delta \\ \Delta |V| \end{bmatrix} \quad (6-19)$$

where the complex bus voltage is written in polar coordinates, $|V| \angle \delta$. The Jacobian matrix can be arranged in many different ways to fit the particular programming techniques selected.

An approximation to the Newton-Raphson formulation can be obtained by observing that, for a small change in the magnitude of bus voltage $\Delta |V|$, the real power, P , does not change appreciably. Similarly, for a small change in bus voltage phase angle $\Delta \delta$, the reactive power, Q , does not change very much. Thus, in Equation (6-19):

$$[J_2] = [\partial P / \partial |V|] \cong 0 \quad (6-20)$$

$$[J_3] = [\partial Q / \partial \delta] \cong 0 \quad (6-21)$$

This allows Equation (6-19) to be “decoupled” into the following form:

$$[\Delta P] = [J_1] [\Delta \delta] \quad (6-22)$$

$$[\Delta Q] = [J_4] [\Delta |V|] \quad (6-23)$$

Note that these two equations can be solved independently and sequentially, thereby reducing the storage and solution time requirements compared to using the full Jacobian. The decoupled Newton-Raphson technique may be used in applications where computational speed is important and the starting solution is close to the actual solution. This situation often occurs where a series of contingencies are being investigated about a previously solved reference case. However, the decoupled technique does not work well for systems with high branch resistance to reactance ratios, such as often found in industrial systems.

6.4.5 Comparison of load flow solution techniques

The techniques described in the previous subclauses are the basic load flow solution techniques. There are many variations and improvements to these techniques that have been developed and incorporated into load flow programs to improve the starting or convergence characteristics.

Although it is useful to understand how load flow solution techniques work, it is more important to understand the characteristics they exhibit. Because their convergence characteristics are dependent upon network, load, and generator conditions, each of the iterative techniques discussed has its own strengths and weaknesses.

Gauss-Seidel methods generally exhibit poor convergence characteristics when compared to Newton methods and thus are no longer widely used for load flow studies. Most of the research into load flow solution techniques has centered on Newton methods. Variations of the Newton methods have been developed to overcome the weaknesses of the original methods, especially the ability to converge from a poor initial voltage estimate.

The modified Newton methods employed by commercial load flow programs combine good convergence characteristics and solution algorithm robustness. Details on such algorithms are available in the references.

6.5 Load flow analysis

A load flow solution determines the bus voltages and the flows in all branches for a given set of conditions. A load flow study is a series of such calculations made when certain equipment parameters are set at different values, or circuit configuration is changed by opening or closing breakers, adding or removing a line, etc. Load flow studies are performed to check the operation of an existing system under normal or outage conditions, to see if the existing system is capable of supplying planned additional loads, or to check and compare new alternatives for system additions to supply new load or improve system performance.

Generally, the study engineer has a predefined set of criteria that the system must meet. These include the following:

- Voltage criteria, such as defined in IEEE Std 141-1993²
- Flows on lines and transformers must be within defined thermal ratings
- Generator reactive outputs must be within the limits defined by the generator capability curves

²Information on references can be found in 6.9.

The voltage criteria are usually divided into an acceptable voltage range for normal conditions and a wider range of acceptable voltage under outage conditions. The thermal criteria for lines and transformers may also have such a division, allowing for a temporary overload capability due to the thermal time constant of the equipment or additional forced cooling capabilities of transformers.

A study normally begins with the preparation of base cases to represent the different operating modes of the system or plant. The operating condition normally chosen is maximum load. (Here maximum load refers to the maximum amount of coincident loaded, not the sum of all the loads. See 4.9 for an explanation of load diversity and load modeling.) When maximum load occurs at different times on different parts of the system, several base cases may be needed. The base cases should represent realistic operating conditions. Abnormal conditions and worst-case scenarios will be addressed later in the study.

The base cases are analyzed to determine if voltages and flows are within acceptable ranges. Sample outputs are shown in 6.6. If voltages or overload problems are noted, system changes can be made to the load flow data and the case resolved to see if the changes are effective in remedying the problem. To remedy low-voltage problems, possible changes include the following:

Change in transformer tap positions

- Increase in generator schedule voltage
- Addition of shunt capacitors
- System reconfiguration to shift load to less heavily loaded lines
- Disconnection of shunt reactors
- Addition of lines or transformers

To remedy heavy line or transformer loadings, most of the same remedies apply. In general, the first two of the above remedies will not help heavy loadings due to large real power (watt) flows. Real power flows from the generators to the loads. Real power flow is determined by the phase angle of the supply bus leading the phase angle of the load bus, with voltage magnitudes having a secondary effect. However, reactive power flow is primarily determined by the voltage magnitude with reactive power flowing from the higher voltage bus to the lower voltage bus. Real and reactive power flow, being primarily influenced by different constraints, can flow in different directions on the same line.

Transformer off-nominal taps can change the relative relationship of the voltage on the primary and secondary bus and thus can change the reactive power flow, while the real power flow is largely unaffected by a change in tap position. When the base case voltages and flows are in the desired range, the system must be examined to check operation under abnormal conditions (contingency analysis). These conditions include the following:

- Loss of a transmission line or cable
- Loss of a transformer
- Loss of a generator
- Abnormal supply conditions

When the load flow model is changed, for example, to represent a line outage, a new solution is obtained. The voltage and flows are checked against their respective criterion. If necessary, further system changes are made to correct the problems noted. In contingency analysis, it is important to note that several outages may cause system problems; but the different remedies applied may not help equally for all outages. To minimize the number and cost of the remedies, it is necessary to choose those remedies that have the most beneficial effects for the most outages. The load flow analysis is used to design a system that has a good voltage profile and acceptable line loadings during normal operation and that will continue to operate acceptably when one or more lines become inoperative due to line damage, lightning strokes, failure of transformers, etc. Performing a series of load flow cases and analyzing the results provides operating intelligence in a short time that might take years of actual operating experience to obtain.

In addition to the benefits described above, a study of reactive power flows on the branches can lead to reduced line losses and improved voltage distribution. Reduction in kVA demand due to power factor correction can lead to lower utility bills for an industrial plant. The size and placement of power factor correction capacitors and the setting of generator scheduled voltages and transformer tap positions can be studied with load flows.

Knowledge of branch flows supplies the protection engineer with requirements for proper relay settings. The load flow studies can also provide data for automatic load and demand control, if needed.

The load flow is also used to check the effects of future load growth and the effectiveness of planned additions. These studies are performed in the same way as studies of the present system. The future loads are determined and entered into the model. Base case conditions are studied and additions made, if necessary, to get the system to meet the performance criteria. Then outage conditions are studied and again system changes may be required. Studies of future systems vary in that there are usually more alternative ways of solving the problems encountered. The load flow is the tool that allows the alternatives to be compared in terms of their effectiveness under normal and contingency conditions. Coupled with other studies as well as cost and reliability data, the results lead to the selection of the best alternative.

6.6 Load flow study example

To illustrate the use of a load flow program, a typical industrial plant will be studied. The single-line diagram of the plant electrical system was shown previously in Figure 6-1.

The first step in performing a load flow study is the preparation of the input data file as explained in 6.3. This data will be input into the load flow program and the network solved. The input data for the sample system is shown in Figure 6-5. Data is given in terms of both physical equipment parameters and per unit.

For existing systems, the network configuration, load, and generation are often chosen to match a known operating condition so results can be compared to values known from operating experience to help validate the model. The base case represents the system in the

Bus Data				
(Total Bus Load Shown - All Loads Modeled as Constant MVA Load)				
Bus Number	Load MW	Load MVAR	Bus Name	Base KV
1	0	0	69-1	69
2	0	0	69-2	69
3	0	0	MILL-1	13.8
4	0	0	MILL-2	13.8
5	0	0	FDR F	13.8
6	0	0	FDR H	13.8
7	0	0	FDR71/72	13.8
8	6.361	0.000	FDR L	13.8
9	0	0	FDR E	0.48
10	0	0	EMERG	13.8
11	0.353	0.200	T4 SEC	2.4
12	0	0	T5 PRI	13.8
13	0	0	T6 PRI	13.8
15	0	0	FDR I	13.8
16	0	0	T9 PRI	13.8
17	0.831	0.521	T5 SEC	0.48
18	0.831	0.521	T6 SEC	0.48
19	2.650	1.502	T7 SEC	2.4
20	2.650	1.502	T8 SEC	2.4
21	0.421	0.283	T9 SEC	0.48
22	0.084	0.057	T5MCC	0.48
23	0.084	0.057	T6MCC	0.48
24	0	0	FDR M	0.48
25	0	0	T10 PRI	13.8
26	0	0	FDR G	13.8
27	0	0	T12 PRI	13.8
28	0.578	0.351	T10 SEC	0.48
29	0.703	0.426	T11 SEC	0.48
30	0.563	0.349	T12 SEC	0.48
31	0	0	FDR P	13.8
32	0	0	FDR Q	13.8
33	0.168	0.113	T10MCC	0.48
34	0.062	0.042	T11MCC	0.48
35	0.168	0.113	T12MCC	0.48
36	1.767	1.001	T13 SEC	2.4
37	0.663	0.394	T14 SEC	0.48
38	0	0	480 TIE	0.48
39	1.237	0.701	T3 SEC	4.16
41	0.150	0.049	LGTS	0.48
49	0.963	0.520	RECT	0.48
50	0	0	GEN1	13.8
51	0.478	0.307	AUX	0.48
100	0	0	UTIL-69	69

Figure 6-5—Input data for sample system

Generator Data					
Bus Number	Unit ID	Real Power (MW)	Reactive Power Upper Limit (MVAR)	Reactive Power Lower Limit (MVAR)	Scheduled Voltage (pu)
100	1	2.0	99.0	-99.0	1.0
4	1	8.0	8.0	-2.0	1.0
50	1	11.0	8.0	-2.0	1.0

CABLE DATA														
From Bus	To Bus	Circuit	Per Unit Data			Cables/Phase and Size	Material	Length (ft)	Length (m)	Rating (MVA)	Rating (Amps)	Resistance	Reactance	
			Resistance	Reactance	Susceptance								Upper Limit (MVAR)	Lower Limit (MVAR)
3	9	1	0.00150	0.00125	0.0	1-3/C-250kcmil CU	PVC	650	198.1	13.8	7.529	315		
9	25	1	0.00424	0.00353	0.0	1-3/C-250kcmil CU	PVC	1833	558.7	13.8	7.529	315		
9	13	1	0.00017	0.00014	0.0	1-3/C-250kcmil CU	PVC	75	22.9	13.8	7.529	315		
9	12	1	0.00038	0.00032	0.0	1-3/C-250kcmil CU	PVC	165	50.3	13.8	7.529	315		
3	5	1	0.00075	0.00063	0.0	1-3/C-250kcmil CU	PVC	325	99.1	13.8	7.529	315		
3	26	1	0.00157	0.00131	0.0	1-3/C-250kcmil CU	PVC	680	207.3	13.8	7.529	315		
3	6	1	0.00109	0.00091	0.0	1-3/C-250kcmil CU	PVC	471	143.6	13.8	7.529	315		
4	15	1	0.00227	0.00189	0.0	1-3/C-250kcmil CU	PVC	980	298.7	13.8	7.529	315		
4	7	1	0.00000	0.00010	0.0	breaker								
7	27	1	0.00143	0.00119	0.0	1-3/C-250kcmil CU	PVC	619	188.7	13.8	7.529	315		
7	16	1	0.00275	0.00229	0.0	1-3/C-250kcmil CU	PVC	1187	361.8	13.8	7.529	315		
10	13	1	0.00046	0.00039	0.0	1-3/C-250kcmil CU	PVC	200	61.0	13.8	7.529	315		
10	12	1	0.00002	0.00002	0.0	1-3/C-250kcmil CU	Steel	10	3.0	13.8	7.529	315		
10	27	1	0.00110	0.00091	0.0	1-3/C-250kcmil CU	PVC	475	144.8	13.8	7.529	315		
4	8	1	0.00076	0.00092	0.0	1-3/C-400kcmil CU	PVC	510	155.4	13.8	9.919	415		
4	24	1	0.00118	0.00098	0.0	1-3/C-250kcmil CU	PVC	510	155.4	13.8	7.529	315		
24	31	1	0.00079	0.00065	0.0	1-3/C-250kcmil CU	PVC	340	103.6	13.8	7.529	315		
24	32	1	0.00112	0.00093	0.0	1-3/C-250kcmil CU	PVC	485	147.8	13.8	7.529	315		
28	38	1	0.03039	0.02929	0.0	2-3/C-400kcmil CU	PVC	50	15.2	0.48	0.445	535		
33	28	1	0.03813	0.02450	0.0	1-3/C-250kcmil CU	PVC	20	6.1	0.48	0.212	255		
29	38	1	0.04012	0.03866	0.0	2-3/C-400kcmil CU	PVC	66	20.1	0.48	0.445	535		
34	29	1	0.03813	0.02450	0.0	1-3/C-250kcmil CU	PVC	20	6.1	0.48	0.212	255		
38	30	1	0.06079	0.05858	0.0	1-3/C-400kcmil CU	PVC	50	15.2	0.48	0.278	335		
35	30	1	0.03813	0.02450	0.0	1-3/C-250kcmil CU	PVC	20	6.1	0.48	0.212	255		
22	17	1	0.03813	0.02450	0.0	1-3/C-250kcmil CU	PVC	20	6.1	0.48	0.212	255		
23	18	1	0.03813	0.02450	0.0	1-3/C-250kcmil CU	PVC	20	6.1	0.48	0.212	255		
50	3	1	0.00122	0.00243	0.0	2-1/C-500kcmil CU	PVC	2000	609.6	13.8	18.350	768		

Figure 6-5—Input data for sample system (Continued)

Transformer Data											
From Bus	To Bus	Circuit	Per Unit Data(10 MVA Base)			Transformer Identifier	Transformer KVA	%Z	X/R	kV Ratio	Tap (kV)
			Resistance	Reactance	Susceptance						
1	3	1	0.00313	0.05324	0.0	T-1	15000	8.00	17.00	69/13.8	69
2	4	1	0.00313	0.05324	0.0	T-2	15000	8.00	17.00	69/13.8	69
5	39	1	0.04314	0.34514	0.0	T-3	1725	6.00	8.00	13.8/4.16	13.8
6	11	1	0.05575	0.36240	0.0	T-4	1500	5.50	6.50	13.8/2.4	13.8
12	17	1	0.06843	0.44477	0.0	T-5	1500	6.75	6.50	13.8/0.48	13.8
13	18	1	0.05829	0.37888	0.0	T-6	1500	5.75	6.50	13.8/0.48	13.8
6	19	1	0.01218	0.14616	0.0	T-7	3750	5.50	12.00	13.8/2.4	13.8
15	20	1	0.01218	0.14616	0.0	T-8	3750	5.50	12.00	13.8/2.4	13.8
16	21	1	0.15036	0.75178	0.0	T-9	750	5.75	5.00	13.8/0.48	13.8
25	28	1	0.05829	0.37888	0.0	T-10	1500	5.75	6.50	13.8/0.48	13.8
26	29	1	0.05829	0.37888	0.0	T-11	1500	5.75	6.50	13.8/0.48	13.8
27	30	1	0.05829	0.37888	0.0	T-12	1500	5.75	6.50	13.8/0.48	13.8
31	36	1	0.02289	0.22886	0.0	T-13	2500	5.75	10.00	13.8/2.4	13.8
32	37	1	0.10286	0.56573	0.0	T-14	1000	5.75	5.50	13.8/0.48	13.8
5	49	1	0.05918	0.35510	0.0	T-17	1250	4.50	6.00	13.8/0.48	13.8
50	51	1	0.06391	0.37797	0.0	T-18	1500	5.75	5.91	13.8/0.48	13.8

Transmission Line Data														
From Bus	To Bus	Circuit	Per Unit Data(10 MVA Base)			Conductors/Phase and Size	Length (ft)	Length (m)	kV	Rating (MVA)	R (W/100ft)	X (W/100ft)	Rating (A)	kV
			Resistance	Reactance	Susceptance									
100	1	1	0.00139	0.00296	0.00480	1-266.8 kemil	10000	3048	69	55				
100	2	2	0.00139	0.00296	0.00480	1-266.8 kemil	10000	3048	69	55				
Busway Data														
From Bus	To Bus	Circuit	Per Unit Data (10 MVA Base)			Material	Length (ft)	Length (m)	R (W/100ft)	X (W/100ft)	Rating (A)	kV		
			Resistance	Reactance	Susceptance									
28	41	1	0.03429	0.02094	0.0	Cu	50	15.2	0.00158	0.000965	1000	0.48		

Figure 6-5—Input data for sample system (Continued)

normal operating mode supplying present maximum loads. Most load flow programs have data checking and analysis routines to help find data input errors. These include a check of the network topology to see that all in-service buses are connected to the swing bus and range checking of certain data items to flag uncharacteristic values. A fundamental check of the base case is to examine the ability of the load flow solution to converge. As noted in 6.4, convergence should lead to a very small amount of MW and Mvar mismatch on every bus, where the mismatch is simply the sum of all the powers or reactive powers entering the bus. The mismatch should ideally equal zero to satisfy Kirchoff's laws; however, a small mismatch is acceptable provided its percentage is small in comparison to the total bus load as a small amount of mismatch will not adversely affect the accuracy of the calculated bus voltages. If the load flow solution cannot approach this point for a known normal operating condition, then a problem in the system model is indicated. Scanning of the load flow output to see buses with large values of mismatch or abnormal voltages will often help find the problem area. The problem could be incomplete or inconsistent data. Short low-impedance lines in close proximity with long lines may make convergence difficult. Very low-impedance lines will likely cause convergence problems unless the load flow program contains special logic in the solution techniques to handle them. Engineering judgment is needed to determine whether it is more appropriate to model these elements explicitly or to lump them with adjacent elements.

Most load flow programs will have the ability to take a solved load flow base case and store all the necessary data including the solution in a file on the computer disk. This will allow easy retrieval of the base case to incorporate future changes or to perform outage condition studies.

One page of the solved load flow output for the sample base case is shown in Figure 6-6 in tabular form. For each bus, the bus voltage magnitude and angle are given. The voltage magnitude may be given as per unit or kV (in this case, both are listed). Each line going from that bus to another bus is listed, giving the MW and Mvar flow (or kW and kvar) on the line out of the "from" bus. A negative flow means the flow is coming into the "from" bus. For transformers, the tap is also listed. If there is significant mismatch on the bus, it will also be listed. Different programs will use somewhat different formats; but they will present basically the same information.

A more concise and usually more informative method of presenting load flow results is to display them graphically on the system single-line diagram. System flows can be quickly analyzed from this visual presentation that relates system configuration, operating conditions, and equipment parameters.

Figure 6-7 displays the base case load flow results in graphical form. This figure shows the voltages on all buses and flows on all lines. As well as this output data, the system configuration is shown clearly: which buses are supplied by each feeder, loads being modeled, generator output, transformer tap ratios, and shunt capacitor values.

Most commercial load flow programs will generate such drawings. As noted before, output format will vary. In Figure 6-7, the line flows are shown near one of the buses and arrows indicate the direction of the MW and the Mvar flow.

PTI INTERACTIVE POWER SYSTEM SIMULATOR--PSS/E WED, JUN 26 1996 08:10
TYPICAL INDUSTRIAL PLANT ELECTRICAL SYSTEM (IEEE BROWN BOOK) WED, JUN 26 1996 08:10
BASE CASE LOAD FLOW SET A RATING SET A

BUS	1	69-1	69.0	AREA	CKT	KW	KVAR	KVA	%I	1.0002PU	0.05	1
TO	3	MILL-1	13.8	1	1	-2667.0	648.5	2744.8	18	1.0000LK		
TO	100	UTIL-69	69.0	1	1	2666.8	-648.5	2744.5	5			
BUS	2	69-2	69.0	AREA	CKT	KW	KVAR	KVA <td>%I</td> <td>0.9993PU</td> <td>-0.10</td> <td>2</td>	%I	0.9993PU	-0.10	2
TO	4	MILL-2	13.8	1	1	5572.0	-368.1	5584.1	37	1.0000LK		
TO	100	UTIL-69	69.0	1	1	-5571.8	368.4	5584.0	10			
BUS	3	MILL-1	13.8	AREA	CKT	KW	KVAR	KVA <td>%I</td> <td>0.9977PU</td> <td>0.88</td> <td>3</td>	%I	0.9977PU	0.88	3
TO	1	69-1	69.0	1	1	2669.4	-608.4	2737.9	18	13.768KV		
TO	5	FDR F	13.8	1	1	2217.0	1340.7	2590.9	34	1.0000UN		
TO	6	FDR H	13.8	1	1	3018.4	1853.3	3541.9	47			
TO	9	FDR E	.480	1	1	1828.4	1191.5	2182.4	29			
TO	26	FDR G	13.8	1	1	769.3	500.2	917.6	12			
TO	50	GEN1	13.8	1	1	-10503.4	-4277.0	11340.8	62			
BUS	4	MILL-2	13.8	AREA	CKT	KW	KVAR	KVA <td>%I</td> <td>1.0000PU</td> <td>-1.81</td> <td>4</td>	%I	1.0000PU	-1.81	4
GENERATION						8000.0	5137.98	9507.8	95	13.800KV		
TO	2	69-2	69.0	1	1	-5562.2	534.4	5587.8	37	1.0000UN		
TO	7	FDR I/7213.8	13.8	1	1	2088.5	1422.7	2527.0	34			
TO	8	FDR L	13.8	1	1	6363.7	3.6	6363.7	64			
TO	15	FDR I	13.8	1	1	2664.1	1647.3	3132.2	42			
TO	24	FDR M	.480	1	1	2445.3	1529.9	2884.5	38			
BUS	5	FDR F	13.8	AREA	CKT	KW	KVAR	KVA <td>%I</td> <td>0.9974PU</td> <td>0.87</td> <td>5</td>	%I	0.9974PU	0.87	5
TO	3	MILL-1	13.8	1	1	-2216.5	-1340.3	2590.2	34	13.764KV		
TO	39	T3 SEC	4.16	1	1	1246.3	775.8	1468.1	85	1.0000LK		
TO	49	RECT	.480	1	1	970.5	565.0	1123.0	90	1.0000LK		
BUS	6	FDR H	13.8	AREA	CKT	KW	KVAR	KVA <td>%I</td> <td>0.9972PU</td> <td>0.87</td> <td>6</td>	%I	0.9972PU	0.87	6
TO	3	MILL-1	13.8	1	1	-3017.0	-1852.1	3540.2	47	13.761KV		
TO	11	T4 SEC	2.40	1	1	353.9	206.1	409.6	27	1.0000LK		
TO	19	T7 SEC	2.40	1	1	2662.0	1646.0	3129.8	84	1.0000LK		
BUS	7	FDR I/7213.8	13.8	AREA	CKT	KW	KVAR	KVA <td>%I</td> <td>1.0000PU</td> <td>-1.81</td> <td>7</td>	%I	1.0000PU	-1.81	7
TO	4	MILL-2	13.8	1	1	-2088.5	-1422.7	2527.0	34	13.800KV		
TO	16	T9 PRI	13.8	1	1	425.3	303.5	522.5	7			
TO	27	T12 PRI	13.8	1	1	1662.6	1119.2	2004.2	27			
BUS	8	FDR L	13.8	AREA	CKT	KW	KVAR	KVA <td>%I</td> <td>0.9995PU</td> <td>-1.84</td> <td>8</td>	%I	0.9995PU	-1.84	8
TO LOAD-PQ						6361.0	0.0	6361.0				
TO	4	MILL-2	13.8	1	1	-6360.6	0.1	6360.6	64			

BUS NUMBER, NAME, BASE KV, AREA NUMBER, CIRCUIT NUMBER.
KW FLOW, KVAR FLOW, KVA FLOW, LINE FLOW IN % OF RATING.

BUS VOLTAGE IN PER UNIT, ANGLE IN DEGREES
BUS VOLTAGE IN KV

TAP POSITION
(LK = TAP ON FROM BUS,
UN = TAP ON TO BUS)

Figure 6-6—Sample load flow output

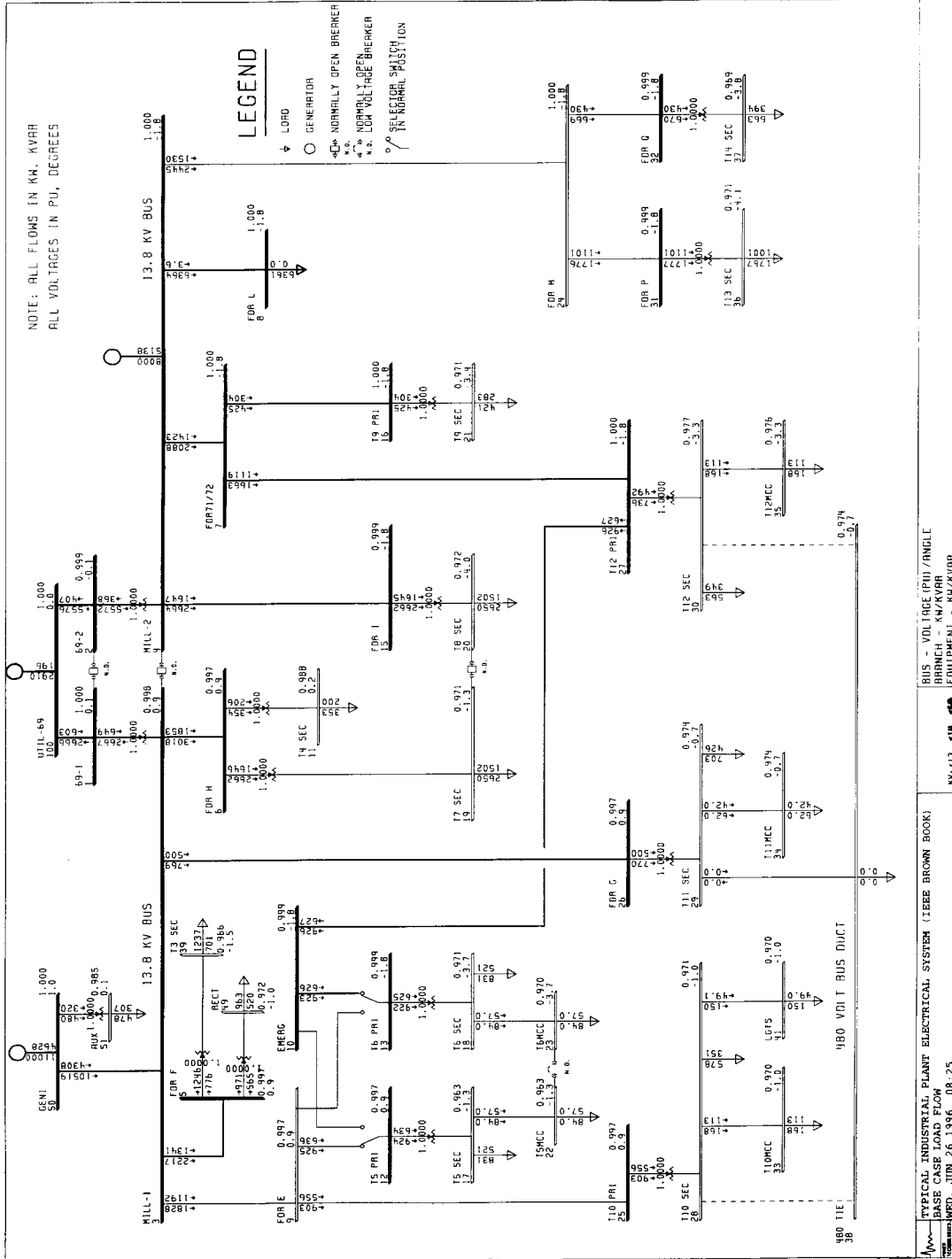

Load flow output as shown in Figure 6-7 provides an excellent opportunity to document study results. Case titles or text on the drawing should indicate the system condition being analyzed. Comments can be entered as to good or poor conditions, or both, that exist in circuit parameters or configuration. It may be desirable to list corrective action taken for the next load flow run, which will hopefully improve the operation.

6.6.1 Analysis of sample system

Now that a load flow has been run for the base condition, what has been learned about the system, and what can be done to improve its operation? Analysis of load flow output shows the following:

- a) Voltage at load buses are generally somewhat low, averaging around 0.97 per unit.
- b) The two plant generators at buses 4 and 50 supply about 87% of the real power load, with the remainder coming from the utility.
- c) The reactive power requirements of the system are also supplied primarily from the plant generators. The reactive power loading on the two generators is large while only a small amount of reactive power comes from the utility.
- d) Loadings on all transformers and cables are within normal operating capabilities.

Conditions in this base case load flow are thus acceptable, although they may not be optimal. The next step would be to see if improvements could be made and to check to see the effects of outages.

One of the most critical contingencies will be outage of one of the plant's generators. Figure 6-8 shows the load flow solution following outage of the generator on bus 50 (along with its auxiliary loads on bus 51). Voltages on load buses fed from bus 3 all drop to 0.93 to 0.94 per unit.

One remedy to these low voltages would be to improve the base case voltage profile. Two methods which could be used are changing the tap position on transformers supplied with off-nominal tap capability or changing the voltage control setpoints of the two generators. To improve voltage profiles following the outage of the generators, the transformer tap changes would be more effective.

Figure 6-9 shows the base case load flow with the following transformer tap changes:

Nominal transformer voltage ratio	Revised off-nominal tap position	Per unit tap
13.8 kV / 4160 V	13.46 kV / 4160 V	0.975
13.8 kV / 2400 W	13.46 kV / 2400 V	0.975
13.8 kV / 480 V	13.46 kV / 480 V	0.975

Note that the voltages at the load buses are now all near unity. With these changes, voltages following the outage of the generator on bus 50 all remain above 0.95 per unit.

The taps on the utility tie transformers were also changed from the nominal 69 kV/13.8 kV to 67.3 kV/13.8 kV or a per unit tap position of 0.975. As the generators hold the main mill buses (3 and 4) near 1.0 per unit, these tap changes do not affect the load bus voltages in the base case condition. However, the change in tap on the supply transformers has a very significant change in the reactive power supply to the plant. The reactive output of the plant generators drops to a small value and almost all of the reactive power needs of the plant come from the utility. This may not necessarily be an improvement; its benefit depends on the demand/power factor terms in the rate structure with the utility. However, the effect of transformer tap positions on reactive power flow is clearly demonstrated.

Another remedy that could be analyzed is changes to the generator voltage setpoints, which will affect both the plant voltage profile and also the relative amount of reactive power supplied by each generator and the system. The effect on real power flows would be minor. Some of the reactive power needs of the plant could also be supplied by capacitors. Analysis of the proper size and placement of capacitors for power factor improvement is explained in IEEE Std 141-1993. The load flow would demonstrate the effectiveness of the proposed capacitor additions.

Any changes made must be checked to see if they result in acceptable conditions for different operating conditions, such as light load in the plant or the utility system supply voltage being higher or lower than the nominal voltage modeled in the base case.

A couple of other examples of plant conditions that could be analyzed are outage of one of the main supply transformers with the closing of the breaker between buses 3 and 4 and the alternate supply of buses 12, 17, and 22 from bus 10. The load flow would be checked to ensure both acceptable voltage levels and that loadings on equipment were within their capabilities. In this manner, the load flow allows the analysis of outages to see if the system will operate in an acceptable (although possibly degraded) condition or if curtailment of the plant's operations would be necessary, and allows alternatives for system improvement to be tested.

Analysis of the system load flow outputs after each set of changes results in the system being gradually tuned to obtain the most efficient and reliable operation. Experience with load flows improves the engineer's ability to make corrections with a minimum number of load flow solutions. However, it is stressed that any change affects the whole system, and a cure at one spot can create unexpected problems at another location in the system. For this reason, it is better not to make too many changes in a single run as the effects on the system may be difficult to understand. Each change case should be documented showing changes made and results obtained in order to keep future changes consistent with improving the system.

6.7 Load flow programs

Many load flow programs are presently available, both in the public domain and as commercial products. These programs may be designed to run on large mainframe computers, medium-sized minicomputers, or on microcomputers, such as personal computers. The various load flow programs differ in the ease of use, program documentation, program sophistication and, of course, cost.

Most load flow programs now operate in an interactive mode, either prompting the user for input and direction in basically a question and answer mode, or using a GUI where the user directs the operation of the program by selecting functions with a “mouse,” i.e., a “windows” interface. This approach is much more efficient from an engineering standpoint than the previous batch-job-oriented programs.

There is a wide range in the level of sophistication in the available programs. There is a corresponding range in the level of user need for this sophistication. The more sophisticated programs may contain several load flow solution techniques allowing for easier solution of a wide range of problems, more data checking activities to help in debugging data input errors, more data handling activities to ease changes to system data or configuration, graphic display of load flow results, ability to handle much larger networks, the modeling of additional power system components, and the incorporation of additional control functions into the solution techniques. For example, load flows are available that will handle 50 000 buses, incorporate such power system elements as HVDC lines and phase shifting transformers, and perform utility area interchange control as part of the solution process. Although essential for large utility systems, a high level of sophistication may not be needed by industrial engineers to analyze their systems.

Since the same network data is used for load flow, short-circuit, transient stability, motor starting, and harmonic studies, it is useful to select a program package that integrates these calculations so that they all use the same load flow network data. Of course, all of the above study capabilities will not be needed by all users.

As an alternative to in-house use of a load flow program, there are consultants who can do the analysis and present the user with a complete report including a technical analysis of the computer output and suggestions and advice on system improvement. Even in this study mode, it is to the user’s advantage to understand the data requirements and how a study is performed.

6.8 Conclusions

It should be evident to designers and operators of industrial plant electrical systems, as well as to utility system engineers, that a tool that predicts the performance of their electrical systems under various operating conditions that can actually be encountered before these conditions occur is of value. Such a tool can be used to prevent expensive outages, damaged equipment, and possibly even loss of life. The load flow solution provides a means to study systems under real or hypothetical conditions. The solution results should be evaluated and

analyzed with respect to optimum present and future operation. This leads to a diagnosis of the system as it exists. The analysis can also point the way to improved operation and provide a meaningful basis for future system planning.

6.9 References

This chapter shall be used in conjunction with the following publications:

IEEE Std 141-1993, IEEE Recommended Practice for Electric Power Distribution for Industrial Plants (IEEE Red Book).³

6.10 Bibliography

Additional information may be found in the following sources:

[B1] Brown, H. E., *Solution of Large Networks by Matrix Methods*, New York, NY: John Wiley and Sons, 1975.

[B2] Stagg, G. W., and El-Abiad, A. H., *Computer Methods in Power System Analysis*, New York, NY: McGraw-Hill, 1968.

[B3] Stevenson, W. D., *Elements of Power System Analysis*, New York, NY: McGraw-Hill, 1975.

[B4] Tinney, W. F., and Hart, C. E., "Power flow solution by Newton's method," *IEEE Transactions on Power Apparatus and Systems*, vol. PAS-86, pp. 1444–1460, Nov. 1967.

[B5] Ward, J. B., and Hale, H. W., "Digital Computer Solution of Power Flow Problems," *AIEE Transactions, Part III—Power Apparatus and Systems*, vol. 75, pp. 398–404, June 1956.

[B6] Wood, A. J., and Wollenberg, B. F., *Power Generation, Operation and Control*, New York, NY: John Wiley and Sons, 1984.

³IEEE publications are available from the Institute of Electrical and Electronics Engineers, 445 Hoes Lane, P.O. Box 1331, Piscataway, NJ 08855-1331, USA.

Chapter 7

Short-circuit studies

7.1 Introduction and scope

Electrical power systems are, in general, fairly complex systems composed of a wide range of equipment devoted to generating, transmitting, and distributing electrical power to various consumption centers. The very complexity of these systems suggests that failures are unavoidable, no matter how carefully these systems have been designed. The feasibility of designing and operating a system with zero failure rate is, if not unrealistic, economically unjustifiable. Within the context of short-circuit analysis, system failures manifest themselves as insulation breakdowns that may lead to one of the following phenomena:

- Undesirable current flow patterns
- Appearance of currents of excessive magnitudes that could lead to equipment damage and downtime
- Excessive overvoltages, of the transient and/or sustained nature, that compromise the integrity and reliability of various insulated parts
- Voltage depressions in the vicinity of the fault that could adversely affect the operation of rotating equipment
- Creation of system conditions that could prove hazardous to personnel

Because short circuits cannot always be prevented, we can only attempt to mitigate and to a certain extent contain their potentially damaging effects. One should, at first, aim to design the system so that the likelihood of the occurrence of the short circuit becomes small. If a short circuit occurs, however, mitigating its effects consists of a) managing the magnitude of the undesirable fault currents, and b) isolating the smallest possible portion of the system around the area of the mishap in order to retain service to the rest of the system. A significant part of system protection is devoted to detecting short-circuit conditions in a reliable fashion. Considerable capital investment is required in interrupting equipment at all voltage levels that is capable of withstanding the fault currents and isolating the faulted area. It follows, therefore, that the main reasons for performing short-circuit studies are the following:

- Verification of the adequacy of existing interrupting equipment. The same type of studies will form the basis for the selection of the interrupting equipment for system planning purposes.
- Determination of the system protective device settings, which is done primarily by quantities characterizing the system under fault conditions. These quantities also referred to as “protection handles,” typically include phase and sequence currents or voltages and rates of changes of system currents or voltages.
- Determination of the effects of the fault currents on various system components such as cables, lines, busways, transformers, and reactors during the time the fault persists. Thermal and mechanical stresses from the resulting fault currents should always be compared with the corresponding short-term, usually first-cycle, withstand capabilities of the system equipment.

- Assessment of the effect that different kinds of short circuits of varying severity may have on the overall system voltage profile. These studies will identify areas in the system for which faults can result in unacceptably widespread voltage depressions.
- Conceptualization, design and refinement of system layout, neutral grounding, and substation grounding.

Compliance with codes and regulations governing system design and operation, such as the National Electrical Code[®] (NEC[®]) (NFPA 70-1996) [B6],¹ article 110-9.

It is not the intention of this chapter to provide details on system modeling and computational procedures under fault conditions, since these topics are exhaustively treated in many comprehensive textbooks and articles (see bibliography) and other IEEE publications such as IEEE Std 141-1993,² IEEE Std 241-1990, and IEEE Std 242-1986. Rather, the intention is to address the subject of short-circuit analysis within the context of three-phase industrial and commercial power systems by focusing on the following:

- a) The concerns and fundamental phenomena associated with short-circuit studies
- b) Viable computational approaches and some aspects of system modeling
- c) Various factors affecting the results and accuracy of short-circuit studies
- d) The salient principles, methodologies, and computational procedures suggested by the North American IEEE and ANSI C37 standards, specifically, ANSI C37.06-1979, ANSI C37.06-1987, IEEE Std C37.010-1979, IEEE Std C37.5-1979, and IEEE Std C37.13-1990). Reference will, however, be made to the international standard, IEC 60909 (1988), because
 - 1) It features several significant conceptual and computational deviations from the C37 standards, and
 - 2) Equipment designed and built according to European specifications is being sold in North America, which should be analyzed on the equipment-tested ratings.
- e) Computer-based solutions and related aspects of software dedicated to computerized fault analysis
- f) The outline of a typical short-circuit study procedure through an example

7.2 Extent and requirements of short-circuit studies

Short-circuit studies are as necessary for any power system as other fundamental system studies such as power flow studies, transient stability studies, harmonic analysis studies, etc. Short-circuit studies can be performed at the planning stage in order to help finalize the system layout, determine voltage levels, and size cables, transformers, and conductors. For existing systems, fault studies are necessary in the cases of added generation, installation of extra rotating loads, system layout modifications, rearrangement of protection equipment, verification of the adequacy of existing breakers, relocation of already acquired switchgear in order to avoid unnecessary capital expenditures, etc. “Post-mortem” analysis may also

¹The numbers in brackets correspond to those of the bibliography in 7.9.

²Information on references can be found in 7.8.

involve short-circuit studies in order to duplicate the reasons and system conditions that led to the system's failure.

The requirements and extent of a short-circuit study will depend on the engineering objectives sought. In fact, these objectives will dictate what type of short-circuit analysis is required. The amount of data required will also depend on the extent and the nature of the study. The great majority of short-circuit studies in industrial and commercial power systems address one or more of the following four kinds of short circuits:

- *Three-phase fault.* May or may not involve ground. All three phases shorted together.
- *Single line-to-ground fault.* Any one, but only one, phase shorted to ground.
- *Line-to-line fault.* Any two phases shorted together.
- *Double line-to-ground fault.* Any two phases connected together and then to ground.

These types of short circuits are also referred to as “shunt faults,” since all four exhibit the common attribute of being associated with fault currents and MVA flows diverted to paths different from the prefault “series” ones.

Three-phase short circuits often turn out to be the most severe of all. It is thus customary to perform only three phase-fault simulations when seeking maximum possible magnitudes of fault currents. However, important exceptions do exist. For instance, single line-to-ground short-circuit currents can exceed three-phase short-circuit current levels when they occur in the vicinity of

- A solidly grounded synchronous machine
- The solidly grounded wye side of a delta-wye transformer of the three-phase core (three-leg) design
- The grounded wye side of a delta-wye autotransformer
- The grounded wye, grounded wye, delta-tertiary, three-winding transformer

For systems where any one or more of the above conditions exist, it is advisable to perform a single line-to-ground fault simulation. The fact that medium- and high-voltage circuit breakers have 15% higher interrupting capabilities for single line-to-ground faults should be taken into account, if elevated single line-to-ground fault currents are found. Line-to-line or double line-to-ground fault studies may also be required for protective device coordination requirements. It should be noted that, since only one phase of the line-to-ground fault can experience higher interrupting requirements, the three-phase fault will still contain more energy because all three phases will experience the same interrupting requirements.

Other types of fault conditions that may be of interest include the so-called “series faults” (Anderson [B1]) and pertain to one of the following types of system unbalances:

- *One line open.* Any one of the three phases may be open.
- *Two lines open.* Any two of the three phases may be open.
- *Unequal impedances.* Unbalanced line impedance discontinuity.

The term “series faults” is used because the above unbalances are associated with a redistribution of the prefault load current. Series faults are of interest when assessing the effects of snapped overhead phase wires, failures of cable joints, blown fuses, failure of breakers to open all poles, inadvertent breaker energization across one or two poles and other situations that result in the flow of unbalanced currents.

7.3 System modeling and computational techniques

7.3.1 AC and dc decrement

The basic physical phenomena that determine the magnitude and duration of the short-circuit currents are

- a) The behavior of the rotating machinery in the system
- b) The electrical proximity of the rotating machinery to the short-circuit location
- c) The fact that the prefault system currents cannot change instantaneously, due to the significant system inductance

The first two can be conceptually linked to the ac decrement, while the third, to the dc decrement.

7.3.1.1 AC decrement and rotating machinery

AC decrement is characterized by the fact that the magnetic flux trapped in the windings of the rotating machinery cannot change instantaneously (constant flux theorem). This gradual change is a function of the nature of the magnetic circuits involved. That is why synchronous machines, under short-circuit conditions, feature different flux variation patterns as compared to induction machines. The flux dynamics dictates that the short-circuit current decays with time until a steady-state value is reached. Computationally convenient machine models, widely used for short-circuit studies, picture rotating machines as constant voltages behind time-varying impedances, as outlined in IEEE Std 141-1993 and IEEE Std 242-1986. For modeling purposes, these impedances increase in magnitude from the minimum post fault subtransient value X''_d , to the relatively higher transient value X'_d , and finally reach the even higher steady-state value X_d , assuming the fault persists long enough (in reality it is the voltage that decays). The rate of increase of machine reactances is different for synchronous generators/motors and induction motors, with the latter increasing more rapidly than the former. This modeling framework is fundamental in properly determining the symmetrical rms values of the short-circuit currents furnished by the rotating equipment for a short circuit anywhere in the system.

7.3.1.2 DC decrement and system impedances

DC decrement is also characterized by the fact that because the prefault system current cannot change instantaneously, a significant unidirectional component may be present in the fault current depending on the exact instant of the occurrence of the short circuit (Anderson [B1], Blackburn [B3], Roeper [B8], Stevenson [B10]). This unidirectional current component,

often referred to as dc offset, decays with time exponentially. The rate of decay is closely related to the system reactances and resistances. Despite the fact that this decay is relatively rapid, the dc component could last long enough to be sensed by the interrupting equipment, particularly when rapid fault clearing is very desirable to maintain system stability or prevent the damaging thermal and mechanical effects of the short-circuit currents. Total fault currents interrupted by circuit breakers must take into account this unidirectional component, particularly for shorter interrupting times as clearly outlined in IEEE Std C37.010-1979, IEEE Std C37.13-1990, and IEEE Std C37.5-1979. The same component is equally important when assessing the ability of a circuit breaker to close against or withstand short-circuit currents. Fault currents containing high dc offsets, often present no zero crossings in the first few cycles immediately after fault initiation and are particularly onerous to the circuit breakers of large generators.

7.3.2 System modeling requirements

Industrial and commercial power systems are normally multimachine systems with many motors and possibly more than one generator, all interconnected through transformers, lines, and cables. There could also be one or more locations at which the local power system is interconnected to a larger grid. These locations are commonly known as “utility-interface” points. The objective of the short-circuit study is to properly determine the short-circuit currents and voltages at various system locations. In view of the dynamic nature of the short-circuit current, it is essential to relate any calculated fault currents to a particular instant in time from the onset of the short circuit. AC decrement analysis serves the purpose of correctly determining the symmetrical rms values of the fault currents, while dc decrement analysis will provide the necessary dc component of the fault current, thus yielding a correct estimate of the total fault current. It is the total fault current which, in general, must be used for breaker and switchgear rating and in some cases for protective device coordination. System topology considerations are equally important because the system layout and electrical proximity of the rotating machinery to the fault location will determine the actual magnitude of the short-circuit current. It therefore becomes necessary to devise a model for the system as a whole and analyze it as such in a flexible, accurate, and computationally convenient manner.

7.3.3 Three-phase vs. symmetrical components representation

It is customary for three-phase electrical systems to be represented on a single-phase basis. This simplification, successfully employed for power flow and transient stability studies, rests on the premise that the system is balanced or at least can be assumed to be so for practical purposes (Anderson [B1], Blackburn [B3], Stevenson [B10], Wagner and Evans [B13]). Modeling the system, however, on a single-phase basis is inadequate for analyzing phenomena that involve serious system unbalances (Anderson [B1], Arrilaga, Arnold, and Harker [B2]). Within the context of short-circuit analysis, only the three-phase shunt fault lends itself to single-phase analysis, because the fault condition is balanced involving all three phases, assuming a balanced three-phase system. Any other fault condition will introduce unbalances that require including in the analysis the remaining two phases. There are two alternatives to address the problem:

- a) *Three-phase system representation.* When the system is represented on a three-phase basis, we explicitly retain the identity of all three phases. The advantage of three-phase representation is that any kind of fault unbalance can be readily analyzed, including simultaneous faults. Furthermore, the fault condition itself is specified with somewhat greater flexibility, particularly for arcing faults. The main disadvantages of the technique are the following:
 - 1) It is not tractable for hand calculations, even for small systems.
 - 2) Supposing that a suitable computer program is used, it can be data-intensive.
- b) *Symmetrical components representation.* The symmetrical components analysis is a technique that, instead of requiring analysis of the unbalanced system, allows for the creation of three subsystems, the positive, the negative, and the zero-sequence systems, properly interconnected at the fault point, depending on the nature of the system unbalance. Once modeled, the fault currents and voltages, anywhere in the network, are then obtained by properly combining the results of the analysis of the three-sequence networks (Anderson [B1], Blackburn [B3] Stevenson [B10], Wagner and Evans [B13]). The distinct advantage of the symmetrical components approach is that it allows modeling unbalanced fault conditions, while still retaining the conceptual simplicity of the single-phase analysis. Another important advantage of the symmetrical components method is that system equipment impedances can be easily measured in the symmetrical components reference frame. This simplification is only true if the system is balanced in all three phases (except at the fault location which then becomes the interconnection point of the sequence networks), an assumption that can be entertained without introducing significant modeling errors for most systems. The main disadvantage of the technique is that for complicated fault conditions, it may introduce more problems than it solves. The symmetrical components technique remains the preferred analytical tool today for fault analysis for both hand and computer-based calculations.

7.3.4 System impedances and symmetrical components analysis

The symmetrical components theory dictates that for a three-phase system, three sequence systems need, in general, to be set up for the analysis of an unbalanced fault condition. The first is the positive sequence system, which is defined by a balanced set of voltages and currents, equal in magnitude, following the normal phase sequence of a, b, and c. The second is the negative sequence system, which is similar to the positive sequence system, but is defined by a balanced set of voltages and currents with a reverse phase sequence of a, c, and b. Finally, the zero sequence system is a system defined by a set of voltages and currents that are in phase with each other and not displaced by 120 degrees, as is the case with the other two systems. The topology of the zero sequence system can be quite different from that of the positive and negative sequence systems due to the fact that it depends heavily on the power transformer connections (Anderson [B1], Blackburn [B3] Stevenson [B10]) and system neutral grounding, factors which are not of importance when determining the topology of the other two sequence networks.

Static system equipment like transformers, lines, cables, busways, and static loads present, under balanced conditions, the same impedances to the flow of positive and negative sequence currents. The same components present, in general, different impedances to the

flow of zero sequence currents. Rotating equipment like synchronous generators, motors, condensers, and induction motors have different impedances in all three sequence networks. The positive sequence impedances are the ones normally used for balanced power flow studies. All sequence impedances must be either calculated, measured, provided by the equipment manufacturers, or estimated. The zero sequence impedance may not exist for some rotating equipment, depending on the machine grounding.

For a balanced three-phase fault analysis, only the positive sequence system components impedances $Z_1 (R_1 + jX_1)$ are required. For line-to-line faults, negative sequence impedances $Z_2 (R_2 + jX_2)$ are also required. For all shunt faults involving ground, i.e., line-to-ground and double line-to-ground, the zero sequence system impedances $Z_0 (R_0 + jX_0)$ are needed in addition to the other two. System neutral grounding equipment data like grounding resistors, reactors, transformers, etc., form an integral part of the zero sequence system impedance data.

AC decrement considerations dictate that rotating equipment impedances vary from the onset of the short circuit. This applies only to positive sequence impedances, which vary from sub-transient through transient to steady-state values. The negative and zero sequence impedances for the rotating equipment are considered unchanged. The same holds true for the impedances of the static system equipment.

7.3.5 Computational approaches

7.3.5.1 Time domain fault analysis

Time-domain fault analysis pertains to techniques that allow for the calculation of the short-circuit current as a function of time from the moment of the fault inception. For large electric power systems, with many machines and generators contributing to the fault current, the contributions of many machines will have to be taken into account concurrently. Machine models have been developed that let predictions of considerable accuracy be made regarding the behavior of any machine for a fault either at or beyond its terminals. These models are rather complex because they tend to represent in detail not only the machine itself but also several nonlinear controllers, such as excitation systems and their related stabilization circuitry, with nonlinearities. It can therefore be seen that the calculating requirements could be stupendous, because the problem is reduced to simultaneously solving a large number of differential equations. Despite its inherent power, the use of time-domain fault analysis is not very widespread and is only used for special studies because it is data-intensive (data requirements can be at least as demanding as transient stability analysis) and it requires special software.

7.3.5.2 Quasi-steady-state fault analysis

Quasi-steady-state fault analysis pertains to techniques that represent the system at steady state. Phasors are used to represent system voltages, currents, and impedances at fundamental frequency. System modeling and the resulting computational techniques are based on the assumption that the system and its components can be represented by linear models. Retaining linearity simplifies considerably the necessary calculations (Anderson [B1], Arrilaga, Arnold, and Harker [B2], Blackburn [B3] Stevenson [B10], Wagner and Evans [B13]) as

demonstrated in Chapter 3. Furthermore, linear algebra theory and the numerical advances in matrix computations make it possible to implement very elegant computer solutions for relatively large systems. These techniques have been favored by the various industry standards and will be briefly examined next.

7.4 Fault analysis according to industry standards

Industry standards dictate certain analytical techniques that adhere to specific guidelines, suited to address the questions of ac and dc decrement in multimachine systems in compliance with well-established, industry-accepted practices. They are also closely linked to and harmonize quite well with existing switchgear rating structures. Typical standards are the North American ANSI and IEEE C37 standards and recommended practices (see 7.4.1), the international standard, IEC 60909 (1988) and others, such as the German VDE 0102-1972 and the Australian AS 3851-1991 (see 7.8). The analytical and computational framework in the calculating procedures recommended by these standards remains algebraic and linear, and the calculations are kept tractable by hand for small systems. The extent of the data base requirements for computer-based solutions is carefully kept to a necessary maximum for the results to be acceptably accurate. This type of analysis represents the best compromise between solution accuracy and simulation simplicity. The great majority of commercial-grade short-circuit analysis programs fall under this category.

In 7.4.1, an outline of ANSI and IEEE standards is presented, while in 7.4.2, the relevant aspects of IEC 60909 (1988) are described. It is not the intent of these subclauses to fully explore and describe in detail all pertinent clauses of either standard. Instead, a rather brief summary is presented in an effort to make any potential user conscious of the salient aspects of each technique. Because only a brief summary is presented, it is strongly recommended that the standards be consulted for further clarifications and details.

7.4.1 The North American ANSI and IEEE standards

IEEE standards addressing fault calculations for medium and high voltage are IEEE Std C37.010-1979, IEEE Std C37.5-1979, IEEE Std 141-1993, IEEE Std 241-1990, and IEEE Std 242-1986. IEEE standards addressing fault calculations for low-voltage systems (below 1000 V), are the IEEE Std C37.13-1990, IEEE Std 141-1993, IEEE Std 241-1990, and IEEE Std 242-1986. Three types of short-circuit currents are defined, depending on the time frame of interest taken from the inception of the fault, as

- a) First cycle currents
- b) Interrupting currents
- c) Time delayed currents

First-cycle currents, also called momentary currents, are the currents at 1/2 cycle after fault initiation; they relate to the duty circuit breakers face when “closing against” or withstanding short-circuit currents. That is why these currents are also called “close and latch” currents. Often these currents contain dc offset, and they are calculated on the premise of no ac decre-

ment in the contributing sources (i.e., the machine reactances remain subtransient [see Table 7-1]). Since low-voltage breakers operate in the first cycle, their interrupting ratings are compared to these currents.

Table 7-1— Generic impedance types required for short-circuit studies

Electrical system equipment type	Momentary 1/2 cycle	Interrupting 3–5 cycles	Time delayed 6–30 cycles
Induction motor	X''_d, R	X''_d, R	Neglect
Synchronous motors	X''_d, R	X''_d, R	See Note 3
Synchronous generators	X''_d, R	X''_d, R	X'_d, X_d, R
Synchronous condensers: electric utility systems	X_s, R_s	X_s, R_s	X_s, R_s
Passive components: transformers, cables, etc.	X, R	X, R	X, R
<p>where</p> <p>X''_d is the subtransient reactance. For induction motors, X''_d is approximately equal to the locked rotor reactance.</p> <p>X'_d is the transient reactance</p> <p>X_d is the synchronous reactance</p> <p>X is the equivalent reactance</p> <p>R is the equivalent modified resistance (see Table 7-2)</p> <p>X_s, R_s is the power company system equivalent reactance and resistance</p>			
<p>NOTES</p> <p>1—See Table 7-2 for exact values.</p> <p>2—X''_d of synchronous machines is the rated voltage (saturated) direct axis subtransient reactance.</p> <p>3—X'_d of synchronous machines is the rated voltage (saturated) direct axis transient reactance.</p> <p>4—For calculations of minimum short-circuit current, contribution is neglected. For calculation of maximum short-circuit current values, use X'_d and R values.</p> <p>5—For more details on IEEE-related induction motor modeling aspects, see Huening [B4].</p>			

Interrupting currents are the short-circuit currents in the time interval from 3 to 5 cycles after fault initiation. They relate to the currents sensed by the interrupting equipment when isolating a fault. Hence, they are also referred to as “contact-parting” currents. These currents are asymmetrical; i.e., they contain dc offset, but due consideration is now given to ac decrement because of the elapsed time from the fault inception. All contributing sources are taken into account when calculating interrupting currents by virtue of reactances that range from subtransient to transient (see Table 7-1). Interrupting currents in the 3 to 5 cycles interval are associated with medium- and high-voltage breakers.

Time delayed currents are the short-circuit currents that exist beyond 6 cycles (and up to 30 cycles) from the fault initiation. They are useful in determining currents sensed by time delayed relays and in assessing the sensitivity of overcurrent relays. These currents are assumed to contain no dc offset. Induction and synchronous motor contributions are neglected, and the contributing generators are assumed to have attained transient or higher value reactances (see Table 7-1).

7.4.1.1 Accounting for ac and dc decrement

In view of the classification of short-circuit currents in three duty types, different impedances are used for the rotating equipment for each of these duties. Tables 7-1 and 7-2 portray the recommended impedances for the system components and for the different types of analysis and duty currents sought. Once the desired duty type has been selected, the appropriate system impedances may be chosen in accordance with Table 7-2.

Table 7-2—Reactance values for first cycle and interrupting duty calculations

Duty calculation	System component	Reactance value for medium- and high-voltage calculations per IEEE Std C37.010-1979 and IEEE Std C37.5-1979	Reactance value for low-voltage calculations (see Note 2)
First cycle (momentary calculations)	Power company supply All turbine generators; all hydrogenerators with amortisseur windings; all condensers	X_S $1.0 X''_d$	X_S $1.0 X''_d$
	Hydrogenerators without amortisseur windings	$0.75 X''_d$	$0.75 X'_d$
	All synchronous motors	$1.0 X''_d$	$1.0 X''_d$
	Induction motors Above 1000 hp	$1.0 X''_d$	$1.0 X''_d$
	Above 250 hp at 3600 r/min	$1.0 X''_d$	$1.0 X''_d$
	All others, 50 hp and above	$1.2 X''_d$	$1.2 X''_d$
	All smaller than 50 hp	$1.67 X''_d$ (see Note 6)	$1.67 X''_d$

**Table 7-2—Reactance values for first cycle
and interrupting duty calculations (Continued)**

Duty calculation	System component	Reactance value for medium- and high-voltage calculations per IEEE Std C37.010-1979 and IEEE Std C37.5-1979	Reactance value for low-voltage calculations (see Note 2)
Interrupting calculations	Power company supply All turbine generators; all hydrogenerators with amortisseur windings; all condensers	X_S $1.0 X''_d$	N/A
	Hydrogenerators without amortisseur windings	$0.75 X'_d$	N/A
	All synchronous motors	$1.5 X''_d$	N/A
	Induction motors Above 1000 hp	$1.5 X''_d$	N/A
	Above 250 hp at 3600 r/min	$1.5 X''_d$	N/A
	All others, 50 hp and above	$3.0 X''_d$	N/A
	All smaller than 50 hp	Neglect	N/A
<p>NOTES</p> <p>1—First-cycle duty is the momentary (or close-and-latch) duty for medium-/high-voltage equipment and is the interrupting duty for low-voltage equipment.</p> <p>2—Reactance (X) values to be used for low-voltage breaker duty calculations (see IEEE Std C37.13-1990 and IEEE Std 242-1986).</p> <p>3—X''_d of synchronous-rotating machines is the rated-voltage (saturated) direct-axis subtransient reactance.</p> <p>4—X'_d of synchronous-rotating machines is the rated-voltage (saturated) direct-axis transient reactance.</p> <p>5—X''_d of induction motors equals 1 divided by per-unit locked-rotor current at rated voltage.</p> <p>6—For comprehensive multivoltage system calculations, motors less than 50 hp are represented in medium-/high-voltage, short-circuit calculations (see IEEE Std 141-1993, Chapter 4).</p>			

The estimates of $1.2 X''_d$ and $1.67 X''_d$ for induction motor impedances to be used for the first cycle network are based on locked rotor impedances of 0.20 and 0.50 per unit, respectively, based on motor rating according to IEEE Std 242-1986. Similarly, the estimate of $3.0 X''_d$, to be used for the induction motor impedance for interrupting duty calculations, is based on the assumption of a locked rotor impedance of 0.28 per unit based on the motor rating, as suggested in IEEE Std 141-1993.

The equivalent Thevenin system impedance at the fault location is then calculated by successive network reduction. Techniques for finding the equivalent short-circuit impedance (reactance) as seen from the fault location are well explained in chapters 3 and 4 of this

recommended practice, in IEEE Std 141-1993, in IEEE Std 241-1990, and in IEEE Std 242-1986. The prefault system voltage, normally assumed to be 1.00 p.u. (rated), divided by the equivalent short-circuit impedance, will yield the desired symmetrical rms value of the desired three-phase fault current. The dc component of the fault current is obtained by considering the X/R ratio at the fault point. The X/R ratio is calculated by taking the ratio of the system reactance (Thevenin equivalent reactance) to the system resistance (Thevenin equivalent resistance) as seen from the fault location. The equivalent reactance must be calculated from the reactance network (X) which is the impedance network of the system under study with all resistances absent. Similarly, the equivalent resistance must be calculated from the resistance network (R), which is the impedance network of the system under study with all reactances absent.

It should be noted that the separate reactance and resistance network reduction technique will yield a different X/R ratio (usually higher) than the phasor X/R ratio of the complex fault impedances.

7.4.1.2 Calculated short-circuit currents and interrupting equipment

The calculating procedures briefly touched upon above are meant to address short-circuit calculations on Industrial power systems with several voltage levels comprising high-, medium-, and low-voltage circuits. First cycle currents are useful in calculating the interrupting requirements of low voltage fuses and breakers. Currents resulting from the same simulation are effectively used in calculating the first-cycle requirements for medium- and high-voltage fuses and circuit breakers. The currents resulting from the so-called interrupting network calculations are only used for medium- and high-voltage circuit breakers, which operate with a certain time delay due to relaying and operating requirements. It must be borne in mind that since low-voltage fuse and circuit breaker application standards like IEEE Std C37.13-1990 have adopted the symmetrical rating structure, calculating only the symmetrical rms fault currents and the X/R ratio may be sufficient, if the calculated X/R ratio is less than the X/R ratio of the circuit breaker test circuit.

A distinction has to be made between the various rating structures of medium- and high-voltage circuit breakers. Breakers rated with the older rating structure, covered by IEEE Std C37.5-1979, are assessed on the basis of the total asymmetrical fault current, or total prospective fault MVA, and calculations are normally restricted to minimum parting time for the sake of safety and simplicity. The more recent rating structure, covered by IEEE Std C37.010-1979, assumes breakers to be rated on a symmetrical basis. Depending on service conditions and the system X/R ratio, the calculated symmetrical short-circuit currents may be sufficient, because a certain degree of asymmetry is embedded in the breaker rating structure.

When calculation of the total fault current is warranted for medium- and high-voltage breaker calculations, IEEE Std C37.010-1979 and IEEE Std C37.5-1979 contain tabulated multipliers that can be applied to the symmetrical rms fault currents in order to obtain asymmetrical rms currents. For IEEE Std C37.5-1979, these currents are the total asymmetrical fault currents, whereas IEEE Std C37.010-1979 represents currents that are to be compared with the breaker interrupting capabilities. In both cases, these multipliers are obtained from curves normalized against breaker contact parting time. As of 1987, the ANSI C37.06-1987 introduced the peak

fault current to the preferred ratings as an alternative to the earlier total asymmetrical fault currents (for first cycle withstand requirements) per ANSI C37.06-1979, in order to better harmonize with IEC standards.

In summary, it should be stressed that an essential step for the calculation of the total fault currents in medium- and high-voltage circuit breaker applications is the determination of portions of the fault current coming from “local” and “remote” sources as a means of obtaining a more reasonable estimate of the breaker interrupting requirements (Huening [B5]). The reason for this distinction is that fault currents from remote sources feature slower, or no, ac current decay as compared to currents coming from local sources. A “remote” contribution, as defined in IEEE Std C37.010-1979, IEEE Std C37.5-1979, IEEE Std 141-1993, and IEEE Std 242-1986, is the fault current that comes from a generator that

- a) Is located two or more transformations away from the fault, or
- b) Has a per unit X''_d that is 1.5 times less than the per unit external reactance on a common MVA basis.

Chapter 4 of IEEE Std 141-1993 provides details on the methods that can be used to determine the appropriate composite adjustment factors that account for local and remote short-circuit contributions. The ratio of the remote source contributions to the total short-circuit current is also known as the NACD ratio (Huening [B5]).

7.4.2 The international standard, IEC 60909 (1988)

IEC 60909 (1988) is similar to the German VDE 0102-1972 standard and to the Australian AS 3851-1991 standard. In what follows, only the very salient aspects are discussed in an effort to make the potential user conscious of its computational and modeling requirements. It is strongly recommended that interested readers consult the standard itself for further details.

IEC 60909 (1988) recognizes four duty types that result in four calculated fault currents:

- The initial short-circuit current I''_k
- The peak short-circuit current I_p
- The breaking short-circuit current I_b
- The steady-state fault current I_k

Although, the breaking and steady-state fault currents are conceptually similar to the interrupting and time-delayed currents, respectively, the peak currents are the maximum currents attained during the first cycle from a fault’s inception and are significantly different from the first-cycle IEEE currents, which are total asymmetrical rms currents. The initial short-circuit current is defined as the symmetrical rms current that would flow at the fault point if no changes are introduced in the network impedances.

The IEC 60909 (1988) provides guidelines for calculating maximum and minimum fault currents. The former are to be used for breaker rating while the latter for protective device coordination. The major governing factors in calculating maximum and minimum fault currents

are the prefault voltages at the fault point and the fact that minimum fault currents are calculated with minimum connected plant.

The phenomenon of ac decrement is addressed by considering the actual contribution of every source, depending on the voltage at its terminals during the short circuit. Induction motor ac decrement is modeled differently than synchronous machinery decrement, because an extra decrement factor representing the more rapid flux decay in induction motors is included. AC decrement is only modeled when breaking currents are calculated.

The phenomenon of dc decrement is addressed in IEC 60909 (1988) by applying the principle of superposition for the contributing sources in conjunction with giving due regard to the topology of the network and the relative locations of the contributing sources with respect to the fault position. In addition, the standard dictates that different calculating procedures be used when the contribution converges to a fault point via a meshed or radial path. These considerations apply to the calculation of peak and asymmetrical breaking currents.

Steady-state fault currents are calculated by assuming that the fault currents contains no dc component and that all induction motor contributions have decayed to zero. Synchronous motors may also have to be taken into account. Furthermore, provisions are taken not only for salient and round rotor synchronous machinery but, also for different excitation system settings.

Prefault system loading conditions are of concern to IEC 60909 (1988) as well. In an attempt to account for system loads leading to higher prefault voltages, the standard recommends that prefault system voltages other than 1.00 per unit be used, without requiring a prefault load flow solution. Furthermore, the standard recommends generator impedance correction factors that may be applicable to their unit transformers as well.

7.4.3 Differences between the ANSI and IEEE C37 standards and IEC 60909 (1988)

The differences between the two standards are numerous and significant (Rodolakis [B7]). Despite the conceptual association in the duty types, system modeling and computational procedures are quite different in the two standards. That is why results calculated using both standards can be quite dissimilar, with IEC 60909 (1988) having the tendency to yield higher fault current magnitudes. The essential generic differences between the two standards can be summarized in the following:

- AC decrement modeling in IEC 60909 (1988) is fault location-dependent and it quantifies the rotating machinery's proximity to the fault. The IEEE standard, on the other hand, recommends universal, system-wide ac decrement modeling.
- DC decrement for IEC 60909 (1988) does not always rely on a single X/R ratio. In general, more than one X/R ratio must taken into account. Furthermore, the notion of separate X and R networks for obtaining the X/R ratio(s) at the fault point is not applicable to IEC 60909 (1988).
- Steady-state fault current calculation in IEC 60909 (1988) takes into account synchronous machinery excitation settings.

In view of these important differences, computer simulations adhering to the ANSI and IEEE C37 standards cannot, in general, be used to cover the computational requirements of IEC 60909 (1988) and vice versa.

7.5 Factors affecting the accuracy of short-circuit studies

The accuracy of the calculated fault currents depends primarily on accurate modeling of the system configuration and the system impedances used for the calculations. Other very important factors include the correct modeling of system rotating load, connected generators, system neutral grounding, and other system components and operating conditions.

7.5.1 System configuration

System configuration consists of the following:

- a) The location of all the potential sources of fault current, i.e., synchronous generators, synchronous motors, induction motors, and utility connection points, and
- b) How these fault current sources are connected through transformers, lines, cables, busways, and reactors.

It is conceivable that more than one single-line diagram should be considered for a given system, depending on the system operating modes and on the nature of the study. If the study is done to assess switchgear adequacy and/or selection, maximum fault currents should be calculated. This entails that fault currents must be calculated under maximum rotating plant and closed bus-ties (whenever applicable), while any utility interconnections should be assumed to attain their highest fault levels. If the study is done to assess protection sensitivity requirements, some of these conditions may need to be relaxed. Different system service conditions may force the study of more than one system topology alternative, particularly in protective relaying studies.

7.5.2 System Impedances

AC and dc decrement modeling considerations are very important factors in properly selecting the impedances of the rotating equipment for short-circuit studies. It is important to consult manufacturer's catalogues, data sheets and, if necessary, to perform some calculations to ascertain reliable impedance values. Typical values can be used in the absence of any other information, but always with caution and a certain degree of conservatism. Table 7-3 portrays some typical values for induction motors.

The values used for the impedances should by no means yield lower fault currents than the ones the system will experience in reality. Underestimating the prospective fault currents can lead to the undersizing of system equipment and to the selection of circuit breakers with inadequate interrupting capabilities. On the other hand, grossly overestimating the fault currents may lead to uneconomical design and less sensitive protection settings. The equivalent impedances representing the power company interconnection points must properly reflect the anticipated fault MVA level. Any ambiguities concerning the impedances of in-plant equip-

Table 7-3—Typical values of motor impedances and kVA ratings to use when exact values are not known^a

Induction motor Synchronous motor, 0.8 pf Synchronous motor, 1.0 pf	1 hp = 1 kVA 1 hp = 1 kVA 1 hp = 0.8 kVA
Motor type	X''_d (See Note)
Synchronous motors 2–6 poles 8–14 poles 16 poles or more	0.15 0.20 0.28
Individual large induction motors, usually medium voltage All others, 50 hp and above All smaller than 50 hp, usually low voltage	0.67 0.67 0.67
NOTE—Motor impedances are in per unit on motor voltage and kVA rating. X''_d for induction motors is approximately equal to the locked-rotor reactance. For induction motors, the locked-rotor reactance is the reciprocal value of the locked-rotor current. Reactances and motor base kVA ratings listed were taken from data and assumptions in IEEE Std 141-1993.	

^aAs specified in IEEE Std 141-1993.

ment should be resolved in favor of higher fault currents for the sake of safety in system design. Impedances of bus ducts, busways, etc., must be accounted for in lower voltage circuits because they effectively limit fault current magnitudes. It is also customary practice to use the saturated impedance values for synchronous machinery.

Last, but not least, the resistive components of the system impedances should be given proper regard if operating system temperature is a factor or if significant lengths of cable runs are present. Although resistance values can usually be omitted for fault current magnitude calculations (E/X calculation), they are important for calculating the system X/R ratio at the fault point. Generally speaking, the total complex system impedance, $Z(R+jX)$ has to be calculated at the fault point to yield a more correct estimate of the fault current (E/Z calculation). This is particularly true for low-voltage systems, where the system resistance is comparable in magnitude to the system reactance and helps limit the fault current.

7.5.3 Neutral grounding

For faults necessitating the inclusion of zero sequence data, i.e., line-to-ground faults, double line-to-ground shunt faults, and series faults, the flow of fault currents is appreciably affected by the system grounding conditions. Of particular concern is the presence of multiple grounding points and the values of system grounding impedances. Grounding impedances can be used, to various degrees, to limit the value of the ground fault current to a minimum value, to suppress resulting overvoltages, and to provide “handles” for ground protection. System grounding can also play an important role in the proper simulation of the system zero sequence response. More specifically, for solidly, or low-impedance grounded systems, it is sufficient to include in the study only the occasional current limiting transformer and or gen-

erator grounding impedances, while disregarding zero sequence line/cable charging shunts. For high-impedance grounded, floating, and/or resonant-grounded systems, however, the latter will have to be taken into account (per IEC 60909 (1988), since the assumption that neglecting it yields conservative (higher) fault currents is no longer valid.

7.5.4 Prefault system loads and shunts

It is customary to assume that the system is at steady state before a short circuit occurs. The simplification of neglecting the prefault load is based on the premise that the magnitude of the prefault system load current is, usually, much smaller than the fault current. The importance of the prefault load current in the system increases with rated system voltage and certain system loading patterns. That is why it is still justifiable for typical industrial power system studies to assume a 1.00 per-unit prefault voltage for every bus. For systems in which prefault loading is a concern, a prefault load flow analysis should precede the fault simulations in order to ascertain a voltage profile for the system that will be consistent with the existing system loads, shunts, and transformer tap settings. If the actual prefault system condition is modeled, it is important to retain for the fault simulation all the system static loads (normally neglected when the system is assumed at rest) as well as the capacitive line/cable shunts.

Standards such as IEC 60909 (1988) and AS 3851-1991 attempt to address this issue by virtue of using elevated prefault voltages and impedance correction factors for the synchronous generators. The ANSI and IEEE C37 practice, however, is centered around considering the prefault voltage as being the nominal system voltage with the notable exception being the assessment of the interrupting requirements of circuit breakers.

7.5.5 Mutual coupling in zero sequence

This phenomenon is of importance when parallel circuits share the same right of way and their geometrical arrangement is such that current flow in one circuit causes a voltage drop in the other. A typical example is exposed overhead lines sharing the same support structure. It should be noted that in reality, mutual coupling exists between phases in the positive sequence as well. This form of mutual coupling, also known as “interphase coupling,” is not explicitly modeled in positive sequence because it is restricted within the same circuit of which only one phase is modeled. Zero sequence coupling, however, is extended between two (or more) circuits and has to be explicitly modeled in zero sequence (Anderson [B1], Arrilaga, Arnold, and Harker [B2], Blackburn [B3], Stagg and El-Abiad [B9], Wagner and Evans [B13]). The implications of neglecting or incorrectly modeling this phenomenon leads to erroneous calculation of ground fault currents and incorrect performance assessment of distance relays. Although relatively infrequent for industrial power system analysis, it should be borne in mind and treated accordingly.

7.5.6 Phase shifts in delta wye transformer banks

When calculating the distribution of the three-phase fault current throughout a system, it is often assumed that, going through transformer banks, the phase of the fault current from

primary to secondary remains the same. This is true only if the transformer is connected wye-wye or delta-delta. When a delta-wye transformer is involved, a phase shift is introduced between the phase quantities of the primary and secondary. The phase shift is present in positive and negative sequence quantities only. Zero sequence quantities are not affected. North American practice dictates that the positive sequence high side line-to-ground voltage must lead the positive sequence low side line-to-ground voltage by 30 degrees. Earlier transformer connections and phase labeling may not comply with that requirement (Wagner and Evans [B13]). The same may also be true for transformers following overseas phasing standards. The computational consequence of not accounting for this phase shift for unbalanced faults is that different current magnitudes are obtained when going through a delta-wye bank because the sequence currents are manipulated vectorially to obtain phase currents. This can lead to inaccurate protective device settings which can, in turn, compromise the selectivity of an overcurrent protection scheme (see also IEEE Std 141-1993 and IEEE Std 242-1986).

7.6 Computer solutions

7.6.1 General

Short-circuit calculations are generally less computationally intensive than other basic power system studies like power flow or harmonic analysis. In view of the fact that short-circuit calculations are linear systems of small to medium sizes can be computationally tractable by hand, particularly if the system resistances are neglected to avoid complex arithmetic. Calculations are further simplified for radial systems. Practical industrial systems, however, can contain several hundred to over one thousand buses, particularly if representation of low-voltage circuits, smaller rotating loads and protective gear is warranted. Under these conditions, computer solutions are the only practical alternative. It should be noted, however, that the speed and reliability of computer-based calculations are rapidly rendering hand-calculations a rarity even for small systems.

7.6.2 Computerized network solutions: System matrices

Hand calculations for determining the equivalent system impedance at a fault point rely on successive and judiciously chosen combinations of the system branches, until the system is reduced to an equivalent Thevenin impedance. This has to be repeated for every new fault location. Since this is done by inspecting the network, the intuition of the analyst is essential. Computers do not have any intuition, that is why different techniques are used. These techniques do not rely on the analyst's inspection abilities, nor do they assume any system topology. That is why they lend themselves very well to both radial and looped systems and are capable of accommodating systems of practically any size. The notions of admittance and impedance matrices are central in realizing any computerized solution scheme.

7.6.2.1 The bus admittance matrix

The bus admittance matrix, also called the Y-matrix, is a square complex matrix (a matrix whose entries are complex numbers) with as many rows and columns as the system buses

(Anderson [B1], Arrilaga, Arnold, and Harker [B2], Stevenson [B10], Stagg and El-Abiad [B9]). The elements of this matrix are either component admittances or sums of component admittances. The term “component admittance” denotes the inverse of the component complex impedance with a component being a system branch, generator, motor, etc. Once the system buses have been identified, this matrix can be constructed as follows:

- Assign a diagonal matrix element to every system bus. The value of the matrix diagonal elements is the sum of the admittances of all the power system components connected to that bus.
- Assign a nondiagonal element to all the matrix elements that represent a system branch. For instance, if a branch is connected between buses i and j , the matrix entry Y_{ij} will be nonzero and equal to the negative sum of the admittances of all components directly connected between buses i and j .

Electric power systems are passive and have very few branches compared to all of the possible bus connections, and as a result, typical power system bus admittance matrices are

- a) symmetric (assuming that transformers are not modeled in off-nominal tap positions) which means that $Y_{ij} = Y_{ji}$, and
- b) sparse, i.e., they feature a lot of zero entries.

7.6.2.2 The bus impedance matrix

The bus impedance matrix, also called the Z -matrix, is defined as the inverse of the admittance matrix (Anderson [B1], Arrilaga, Arnold, and Harker [B2], Stevenson [B10], Stagg and El-Abiad [B9]). This complex matrix is also square and symmetric, i.e., the entry Z_{ij} equals the entry Z_{ji} , for passive networks. As the inverse of the sparse Y -matrix, however, this matrix is a full matrix having no zero entries. It can be proved that the diagonal entries, Z_{ii} for bus i , of this matrix are the equivalent Thevenin impedances used for fault calculations. The entry Z_{ij} , however, does not necessarily represent the value of the impedance of the physical connection between buses i and j . In fact, there is always an impedance Z_{ij} despite the fact that there may not be a branch between buses i and j . The diagonal entries of the Z -matrix are used in calculating fault currents, while the nondiagonal entries are useful for calculating branch contributions and system-wide voltage profiles under fault conditions.

7.6.2.3 System topology, matrix sparsity, and solution algorithms

The sparsity of the Y -matrix requires that special techniques be employed for storing the system data, because conceptually straightforward storage techniques may be quite wasteful. Storing, for instance, the entire Z -matrix is not only impractical but unnecessary because only a few of its elements may be needed. The development of solution algorithms, therefore, has been focusing on the efficient retrieval of the necessary Z -matrix entries with the smallest possible storage and calculation requirements. Modern vintage computer software employs calculation and system data storage schemes that center around the so-called “sparse vector” and/or “sparse matrix” solution techniques (Tinney, Brandwajn, Chan [B12]) which render very rapid and accurate solutions.

7.6.3 Computer software

7.6.3.1 General

The availability of commercial grade computer software on personal computers has been steadily increasing in variety and computational power since the early 1980s, although sophisticated software has existed for more powerful hardware platforms such as mainframes and minicomputers since the early 1960s (St. Pierre [B11]). The personal computer is now recognized as a credible computational tool due to the significant advances it has enjoyed in processor architecture, speed, memory capacity, and in user-friendly operating systems and environments. Computer programs that addressed short-circuit calculations were among the first to be developed in all platforms. All programs rely on matrix techniques and require the analyst to provide accurate system data so that the computer can proceed with the analysis and produce the results.

7.6.3.2 Selecting software

The great variety of commercially available computer programs for short-circuit calculations can be attributed to the wide variety of the analytical tasks they perform, the degree of sophistication in user-interface and user-friendliness, and the computer platform for which they are designed. Because the variety of the available computer software is accompanied by an equally impressive variation in prices, it is important to acquire software that best corresponds to the bulk of the engineering mandates for which it is purchased. It is questionable, from an investment point of view, to acquire expensive and very sophisticated software when the bulk of its analytical features will never be used. On the other hand, it could prove shortsighted to acquire inexpensive software that will rapidly be outgrown by the needs of its user, compromise the accuracy of the study, or result in a consistent waste of time and resources due to inherent functional inefficiencies. It is also important to assess the degree of user-friendliness of the software versus the computer-literacy of the personnel who will be using it. Many engineers are reluctant to refamiliarize themselves with bulky user's guides only to perform studies with which they are very familiar. It pays to work with software that features easy data entry, meaningful and helpful diagnostic messages, and comprehensive reports. Last, it is essential to acquire software that is very well documented, promptly supported, and regularly updated and upgraded by its vendors.

7.6.3.3 Features of short-circuit analysis software

The previously mentioned general salient principles governing software selection are supplemented by a good number of other features that are particularly applicable to short-circuit analysis. A very important aspect in short-circuit studies is data preparation, a stage which, by itself, can be computationally demanding, particularly if the software accepts system data only on a per-unit basis. It is essential for the program to help the analyst prepare the data for the study and provide means of identifying and correcting obvious and common mistakes. Furthermore, whenever international standards are to be used, it is important for the software to provide sufficient information and results that are transparent enough to allow for more than one interpretation.

Table 7-4 contains several features that computer programs may or may not support. These features have been conceptually categorized as “very desirable,” “desirable,” and “optional.” “Very desirable” means that the feature is widely encountered and rather indispensable. The category “desirable” addresses features that will prove of value to more demanding studies. The category “optional” covers features that may prove to be of value for special studies.

Table 7-4—Analytical features of short-circuit computer programs

Analytical feature	Very desirable	Desirable	Optional
Systems with more than one voltage level	Yes		
Looped and radial system topology	Yes		
Ground faults (LG and LLG)	Yes		
Series faults (See Note 1)		Yes	
Arcing faults (See Note 2)			Yes
Simultaneous faults			Yes
Complex arithmetic	Yes		
Explicit negative sequence (See Note 3)			Yes
Interface with power flow (See Note 1)		Yes	
Currents in all three phases (See Note 4)	Yes		
Currents in all three sequences (See Note 4)	Yes		
One-bus-away fault contributions	Yes		
Line monitors (See Note 5)		Yes	
Input data reports	Yes		
Protection coordination interface		Yes	
Voltages in nonfaulted buses (See Note 5)		Yes	
Summary reports		Yes	
Currents in all branches (See Note 5)		Yes	
Per-unitization of equipment data		Yes	
Rotating equipment impedance adjustment (IEEE Std C37.010-1979)	Yes		
Separate X and R reduction for X/R ratios (IEEE Std C37.010-1979)	Mandatory		

Table 7-4—Analytical features of short-circuit computer programs (*Continued*)

Analytical feature	Very desirable	Desirable	Optional
Remote and local fault contributions (IEEE Std C37.010-1979)	Mandatory		
First cycle fault currents (IEEE Std C37.010-1979)	Mandatory		
Interrupting fault currents (IEEE Std C37.010-1979)	Mandatory		
Time-delay fault currents (IEEE Std C37.010-1979)		Yes	
Symmetrical current multiplying factors (IEEE Std C37.010-1979)	Yes		
Total current multiplying factors (IEEE Std C37.5-1979 factors)	Yes		
Multiplying factors (IEEE Std C37.13-1990)	Yes		
<i>X/R</i> —dependent 1/2 cycle multipliers (IEEE Std C37.010-1979)	Yes		
<i>X/R</i> —dependent peak multipliers (IEEE Std C37.010-1979)	Yes		
Transformer phase shifts (See Note 4)	Yes		
Mutual coupling in zero sequence (See Note 6)			Yes
Methodology in accordance with IEC 60909 (1988) (See Note 7)		Yes	
<p>NOTES</p> <p>1—Series faults are normally modeled when a pre-fault power flow solution is available and pre-fault load can be taken into account.</p> <p>2—Arcing faults can be of consequence when assessing the sensitivity of ground protection in solidly grounded systems. Conservative estimates of fault levels, however, will result by assuming bolted faults.</p> <p>3—Negative sequence system representation is not warranted by ANSI and IEEE C37 standards, though it could be of significance when ground faults near large generating stations are calculated, or when simulations compatible with IEC 60909 (1988) require elevated accuracy.</p> <p>4—It is important to have a good estimate of all three phase and sequence currents, particularly for protection requirements. In correctly estimating all these currents in magnitude and phase it is very helpful to take into account phase shifts in transformer banks.</p> <p>5—When assessing the degree of severity of a fault, it is often of interest to see how nearby system areas are affected, and if protective devices will be activated as a result of the fault.</p> <p>6—Mutual coupling in zero sequence normally affects overhead circuitry sharing a common right-of-way. For industrial power systems analysis, zero sequence mutual coupling can be of concern if such circuits are modeled and the performance of protective devices requiring zero sequence current compensation is investigated.</p> <p>7—Support of the IEC 60909 (1988) may require dedicated software.</p>			

7.7 Example

In what follows, a short-circuit study is carried on a typical industrial system in order to illustrate typical steps, calculation requirements, and results. The system is composed of circuits of several voltage levels, local generation, a utility interconnection, and a variety of rotating loads. The study is carried out according to the ANSI and IEEE C37 standards (see 7.8).

7.7.1 Determination of the scope and extent of the study

Determination of the scope extent and the desired accuracy of the study is crucial, because these factors will dictate what types of faults are to be simulated and to what degree system modeling is to be undertaken. The type and number of fault studies for a given system is determined by engineering judgment, which is based on the various forms the system layout may assume during operation or the specific purpose of the study.

The study results may be used for recommending changes to existing plants or for proposing an initial design for a system in its planning and/or expansion stage. Some important questions for which fault studies may help provide answers are as follows:

- a) Is circuit interrupting equipment adequate for the system interrupting requirements at all voltage levels? Can the medium- and high-voltage switchgear withstand the momentary and interrupting duties imposed by the system? Is this switchgear adequate for line to ground faults? If not, should new equipment be purchased or can some changes to the system be effected to avoid the extra capital expenditure?
- b) Is there any reserve in the interrupting capability of the circuit breakers for accommodating future system expansion? If not, is it necessary to have a safety margin for future expansion? If so, how can the system be changed to accommodate these concerns?
- c) Is noninterrupting equipment, i.e., reactors, cables, transformers, bus ducts, adequately rated to withstand short-circuit currents until cleared by the interrupting equipment?
- d) Do load circuit breakers or disconnecting switches have sufficient momentary bracing and/or close-and-latch capabilities?
- e) What will be the effect on the calculated short-circuit currents in the plant system if there is an increase in the power company's short-circuit level? Economically, what can be done to anticipate such an eventuality?
- f) Is special protective equipment or circuitry necessary to provide protective device selectivity for both maximum and minimum value of short-circuit currents?
- g) During faults, do the voltages on unfaulted buses in the system drop to levels that can cause motor-starter contactors to drop out or undervoltage relays to operate?

Every study will have to be assessed on its own merits and its results interpreted only for the purpose the study was conducted. The short-circuit study for the example in question is performed for the purposes of determining the interrupting requirements for low-, medium-, and high-voltage switchgear. It is not uncommon for these types of studies to consider only three-phase fault currents, since, as a rule, they yield the more severe interrupting requirements, as compared to other shunt faults, and the industrial power systems are often impedance-

grounded. Line-to-ground fault simulations are necessary for circuit-breaker-adequacy evaluation and/or selection, if the system is such that line-to-ground fault currents may exceed three-phase fault currents (see 7.2). Only three-phase, bolted, shunt faults will be considered for the example.

7.7.2 Preparation of the system one-line diagram and collection of data

The one-line diagram of the system is shown in Figure 7-1. We will consider that both in-plant generators are connected and that both of the utility service entrance transformers are in service. The system rotating load, as shown in the one line diagram, represents an operating condition that is typical for the system operating at or near full capacity. Furthermore, it is known that the bus ties between buses 3 and 4 (13.8 kV) and between buses 1 and 2 (69 kV) are open. Cable runs between buses, 9 (FDR E) and 13 (T6 PRI), 28 (T10 SEC) and 38 (480 TIE), 30 (T12 SEC) and 38 (480 TIE), 10 (EMER) and 12 (T5 PRI), are also assumed to be open. It is this particular system layout that will be studied. In general, however, depending on the type of study, more than one single-line diagram may have to be considered in practice (see 7.5.1).

Data necessary for conducting a short-circuit study comprise the following:

- a) Utility interconnection points and associated fault MVA levels (both three-phase and line-to-ground) in order to determine the equivalent impedance of the utility
- b) In-plant generation data
- c) Rotating load data comprising synchronous motors and induction motors, both stand-alone and grouped
- d) Static system equipment data, such as transformers, cables, reactors, overhead lines, busways, bus ducts, etc., switching equipment and, in some cases, static loads (heaters, drives, etc.).

7.7.3 Determination and per-unitization of system impedances

7.7.3.1 Determination of the required system impedances

The choice of system impedances to be used depends on the type of study to be performed and the actual fault conditions to be simulated. Three-phase fault studies require only positive sequence impedances, whereas faults involving ground will require zero sequence system data as well as any neutral grounding data. Negative sequence impedances may also be necessary for line-to-line fault simulations. Impedances of both static and rotating system components are normally known from equipment nameplate data. In the absence of detailed information, typical values are assumed. Nameplate impedances of rotating equipment are modified from their rated values in order to account for ac decay, according to the North American practice (see 7.4.1).

7.7.3.2 Per-unitization of the system impedances

Power system equipment impedances are expressed on a unified per-unit basis because

- a) Carrying out the calculations in ohms is not practical for systems composed of more than one voltage level, and
- b) The impedances of the system components are expressed in terms of their rated voltage and power.

When the per-unitization of the system impedances to a common MVA base is done manually, caution is required because this is a common source of errors. It is also one of the most time-consuming tasks of a short-circuit study. Computer programs, in general, operate internally on per-unitized impedances, and many offer the facility to convert the “raw” system data to per-unit data in a form ready to be used by the program. If this is the case, it is important to comprehend how the per unitization is carried out. This will greatly facilitate any future “what if” analysis because of different system layouts or modified system impedances. In any case, any error in per unitizing the system impedances can seriously compromise the accuracy of the short-circuit study.

Per-unit impedances are defined as the ratio of the actual ohmic component impedances to a certain base impedance (see also Chapters 3 and 4). The base impedances are calculated from a common, arbitrarily chosen, apparent power base and from a base voltage (Anderson [B1], Stevenson [B10]).

$$Z_{\text{p.u.}} = \frac{Z_{\text{ohms}}}{Z_{\text{base}}}, \text{ with } Z_{\text{base}} = \frac{V_{\text{base}}^2}{S_{\text{base}}} \quad (7-1)$$

The power base is usually expressed in MVA and is applicable throughout the system. The base voltage is expressed in kilovolts (if base power is in MVA) and selected differently for every system section, following the nominal voltage ratios of the system power transformers. If single phase power is chosen, line-to-ground voltages should be used. Alternatively, if three phase power is chosen as base line to line voltages are in order. It is practical to select as base voltages the rated transformer voltages. All buses in the same network section must share the same voltage base. Equipment like transformers, generators, motors, etc., have their impedances given in percent (per unit $\times 100$) of their rated voltage and power. It is often necessary to convert these impedances to new base quantities as follows:

$$Z_{\text{p.u., new}} = \frac{S_{\text{new}}}{S_{\text{old}}} \frac{V_{\text{old}}^2}{V_{\text{new}}^2} Z_{\text{p.u., old}} \quad (7-2)$$

In what follows, some per-unit impedances used in the example study are calculated.

7.7.3.3 Power company per-unit impedance

Assuming that the three-phase MVA fault level at bus 100-UTIL-69 is 1000 MVA, the per-unit impedance of the power company, for a 10 MVA base for the system, is calculated to be

$$Z_{\text{utility}} = \frac{\text{MVA}_{\text{base}}}{\text{MVA}_{\text{fault}}} = \frac{10}{1000} = 0.01 \text{ p.u.} \quad (7-3)$$

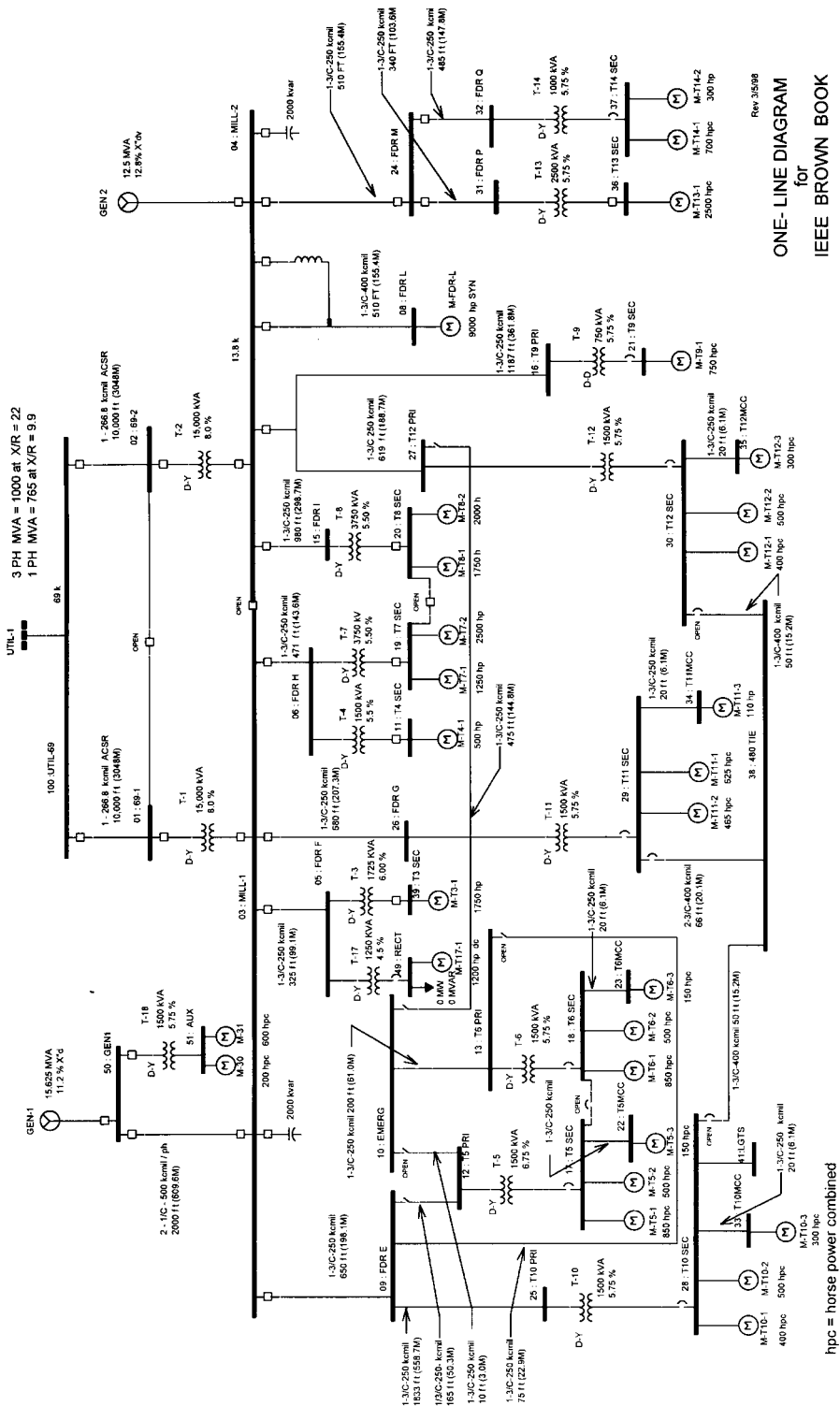

Figure 7-1—One-line diagram

Assuming a typical X/R ratio of 22.0, the utility equivalent impedance becomes

$$Z^2 = R^2 + \frac{X^2}{R^2}R^2 = R^2\left(1.0 + \frac{X^2}{R^2}\right), \text{ from which}$$

$$Z_{\text{utility}} = 0.000454 + j0.00999 \text{ p.u.}$$

This impedance will be applied for both first cycle and interrupting duty calculations because the power company is considered always to be a “remote” source, thus featuring no ac decrement.

7.7.3.4 Power cable per-unit impedance

Power cable impedances are normally provided in $\Omega/1000$ ft. Consider, as an example, the cable connecting buses 3-MILL-1 and 9-FDRE, which is a 250MCM, 3-core, copper conductor, PVC-jacketed cable, and applied at 13.8 kV. The impedance of the cable is $Z = 0.0440419 + j0.0366795 \Omega/1000$ ft. The cable conduit between the two buses spans 650 ft. The impedance of this cable expressed in per unit of system data will be

$$Z_{\text{cable p.u.}} = 0.650(0.0440419 + j0.0366795) \frac{10.00}{13.8^2} = 0.0015032 + j0.0012519 \text{ p.u.}$$

This impedance, as with all impedances of power cables and overhead circuitry, will be applied as is for both first cycle and interrupting calculations. Impedance correction decrement factors apply only to rotating induction and synchronous loads and in some cases to synchronous generators (see Table 7-2).

7.7.3.5 Synchronous generator per-unit impedance

The generator connected on bus 4-MILL-2 has a rated power of 12.5 MVA, a rated voltage of 13.8 kV, a subtransient reactance of 12.8%, and an X/R ratio of 35.7. The reactance of the generator on the common system MVA base of 10 MVA is found to be

$$X_{\text{p.u., new}} = \frac{\text{MVA}_{\text{new}}}{\text{MVA}_{\text{old}}} \frac{V_{\text{old}}^2}{V_{\text{new}}^2} \frac{13.8^2}{13.8^2} 0.128 = 0.1024 \text{ p.u.}$$

The generator impedance, for the given X/R ratio, therefore becomes

$$Z_{\text{p.u.}} = \frac{0.1024}{35.7} + j0.1024 = 0.002868 + j0.1024 \text{ p.u.}$$

For the example at hand, it will be assumed that all generators are turbo generators, thus ac decrement impedance correction factors will be equal to 1.00 for interrupting duty calculations.

7.7.3.6 Synchronous motor per-unit impedance

Consider the synchronous motor connected at bus 8-FDR-L. This motor has a subtransient reactance of 20.00%, an X/R ratio of 34.00, and is rated 9000 kVA at 13.8 kV. The motor impedance, expressed on a 10 MVA, 13.8 kV base reference, will then be

$$Z_{\text{syn p.u.}} = \left(\frac{0.20}{3.40} + j0.20 \right) \frac{10.00}{9.000} \frac{13.8^2}{13.8^2} = 0.006534 + j0.2222 \text{ p.u.}$$

The impedance calculated for the synchronous motor is applicable to both first cycle and interrupting calculations (see Table 7-2).

7.7.3.7 Induction motor per-unit impedances

7.7.3.7.1 Small induction motors

The motor load at bus 51-AUX partly consists of many small motors rated below 50 hp, totaling 570 hp, connected at 480 V, rotating at 1800 r/min. Assuming a total equivalent locked rotor reactance of 16.7% and an X/R ratio of 12.00, the per-unit impedance of the group of motors becomes

$$Z_{\text{p.u.}} = \left(\frac{0.167}{12.00} + j0.167 \right) \frac{10.00}{0.570} \frac{0.48^2}{0.48^2} 1.67 = 0.40773 + j4.89278 \text{ p.u.}$$

Alternative interpretations of IEEE Std C37.010-1979 and IEEE Std C37.13-1990, governing first-cycle duty calculations, recommend omitting these motors for medium- and high-voltage, while considering them for low-voltage calculations. By applying the factor 1.67, both high- and low-voltage circuits are modeled in one network and a single computer simulation will suffice. For medium- and high-voltage interrupting duty calculations, these motors are neglected (see Table 7-2).

7.7.3.7.2 Medium-sized induction motors

The motor load at bus 51-AUX also comprises a medium-sized induction motor, rotating at 1800 r/min, rated 200 kVA (200 hp with 0.746 power factor) at 480 V, with a locked rotor reactance of 16.7% and an X/R ratio of 7.00. According to Table 7-2, the per-unit motor impedances to be used in first cycle (impedance adjustment factor of 1.2) and interrupting duty (impedance adjustment factor of 3.0) calculations are

$$Z_{\text{first cycle p.u.}} = \left(\frac{0.167}{7.00} + j0.167 \right) \frac{10.00}{0.200} \frac{0.48^2}{0.48^2} 1.20 = 1.43143 + j10.0200 \text{ p.u.}$$

$$Z_{\text{inter. p.u.}} = \left(\frac{0.167}{7.00} + j0.167 \right) \frac{10.00}{0.200} \frac{0.48^2}{0.48^2} 3.00 = 3.57858 + j25.0500 \text{ p.u.}$$

7.7.4 Example system data

The data for the example system components are shown in Tables 7-5 through 7-12. The data for rotating equipment and transformers are presented in raw form, as would typically be seen on the nameplates of the various apparatus.

Table 7-5—Example system generator data

GEN-ID	Rated kV	Rated MVA	X''_d (%)	X/R ratio	X_o (%)	X_o/R_o ratio
GEN-1	13.8	15.625	0.11200	37.4	5.7	37.4
GEN-2	13.8	12.50	12.8	35.7	5.80	35.7

Table 7-6—Example system utility interconnection data

Connection point	3PH-MVA	X/R ratio	L-G MVA level	X/R ratio
UTIL-1	1000.00	22.00	765.00	9.70

Table 7-7—Example system overhead line data (impedances in Ω /mi)

Line ID	Rated kV	Conductor size	R_1 (Ω /mi)	X_1 (Ω /mi)	Length (mi)
L-1	69.00	266.8 MCM	.34940	.744063	1.894
L-2	69.00	266.8 MCM	.34940	.744063	1.894

Table 7-8—Example system fixed-tap transformer data

XMR ID	Rated MVA	Primary		Secondary		Z_1 (%)	X_1/R_1 ratio	Z_o (%)	X_o/R_o ratio
		kV	Bus	kV	Bus				
T-1	15.0	69.00	01	13.80	03	8.00	17.000	7.20	17.000
T-10	1.50	13.80	25	0.48	28	5.75	6.500	5.75	6.500
T-11	1.50	13.80	26	0.48	29	5.75	6.500	5.50	6.500
T-12	1.50	13.80	27	0.48	30	5.75	6.500	5.50	6.500
T-13	2.50	13.80	31	2.40	36	5.75	10.000	50.00	10.000

Table 7-8—Example system fixed-tap transformer data (Continued)

XMR ID	Rated MVA	Primary		Secondary		Z_1 (%)	X_1/R_1 ratio	Z_o (%)	X_o/R_o ratio
		kV	Bus	kV	Bus				
T-14	1.00	13.80	32	0.48	37	5.75	5.500	50.00	5.500
T-17	1.25	13.80	05	0.48	49	4.50	6.000	4.50	6.000
T-18	1.50	13.80	50	0.48	51	5.75	5.914	5.75	5.910
T-2	15.0	69.00	02	13.80	04	8.00	17.00	7.40	17.000
T-3	1.725	13.80	05	4.16	39	6.00	8.000	6.00	8.000
T-4	1.50	13.80	06	2.40	11	5.50	6.500	5.50	6.500
T-5	1.50	13.80	12	0.48	17	6.75	6.500	6.75	6.500
T-6	1.50	13.80	13	0.48	18	5.75	6.500	5.75	6.500
T-7	3.75	13.80	06	5.50	19	5.50	12.000	5.50	12.000
T-8	3.75	13.80	15	2.40	20	5.50	12.000	5.50	12.000
T-9	0.75	13.80	16	0.48	21	5.75	5.000	5.50	5.000

Table 7-9—Example system busway data (impedances in $\Omega/100$ ft)

Busway ID	Rated kV	Size (A)	R_1 (Ω)	X_1 (Ω)	Length (ft)	From bus	To bus
SQD-I-Li	0.48	1000	0.0016	0.0010	50.0	28	41

7.7.5 Results

It is not uncommon for computer programs to automatically perform the conversion of the raw system data to per-unit data ready to be used by the computer package. The results of such a conversion are illustrated in Figure 7-2, as reported by the computer program. These data consist of transformer, cable, and line data.

Furthermore, since the study is to follow IEEE Std 141-1993 and IEEE Std 242-1986 and is carried out for switchgear adequacy verification purposes, two separate studies are required. Both simulations will generate three-phase fault currents, the first, yielding the first-cycle fault currents (also known as momentary or close- and latch-currents), and the second, providing the interrupting currents. Strictly speaking, the same studies should be repeated for line-to-ground faults if system conditions conducive to the generation of line-to-ground fault currents could exceed the three-phase fault-interrupting requirements (see 7.2).

Table 7-10—Example system cable data (impedances in $\Omega/1000$ ft)

Cable ID	kV	Length (ft)	From bus	To bus	R_1 (Ω)	X_1 (Ω)	R_o (Ω)	X_o (Ω)
C-E1	13.8	650	03	09	0.04404	0.03668	0.0808	0.07336
C-E2	13.8	1833	09	25	0.04404	0.03668	0.08808	0.07336
C-E3	13.8	75	09	13	0.04404	0.03668	0.08808	0.07336
C-E4	13.8	165.0	09	12	0.04404	0.03668	0.08808	0.07336
C-F1	13.8	325.0	03	05	0.04404	0.03668	0.08808	0.07336
C-G1	13.8	680.0	03	26	0.04404	0.03668	0.08808	0.07336
C-H1	13.8	471.0	03	06	0.04404	0.03668	0.08808	0.07336
C-I1	13.8	980.0	04	15	0.04404	0.03668	0.08808	0.07336
C-J2	13.8	619.0	04	27	0.04404	0.03668	0.08808	0.07336
C-J3	13.8	1187.0	16	04	0.04404	0.03668	0.08808	0.07336
C-J4	13.8	200.0	10	13	0.04404	0.03668	0.08808	0.07336
C-J5	13.8	10.0	10	12	0.04404	0.04214	0.08808	0.08429
C-J6	13.8	475.0	10	27	0.04404	0.03668	0.08808	0.07336
C-L1	13.8	510.0	04	08	0.02831	0.03424	0.05661	0.06847
C-M1	13.8	510.0	04	24	0.04404	0.03668	0.08808	0.07336
C-M2	13.8	340.0	24	31	0.04404	0.03668	0.08808	0.07336
C-M3	13.8	485.0	24	32	0.04404	0.03668	0.08808	0.07336
C-T10-1	0.48	50.0	28	38	0.02801	0.02699	0.05602	0.05399
C-T10-2	0.48	20.0	33	28	0.04393	0.02823	0.08786	0.05645
C-T11-1	0.48	66.0	29	38	0.04393	0.02699	0.05602	0.05399
C-T11-2	0.48	20.0	34	29	0.04393	0.02823	0.08786	0.05645
C-T12-1	0.48	50.0	38	30	0.02801	0.02699	0.05602	0.05399
C-T12-2	0.48	20.0	35	30	0.04393	0.02823	0.08786	0.05645
C-T5-1	0.48	20.0	22	17	0.04393	0.02823	0.08786	0.05645
C-T6-1	0.48	20.0	23	18	0.04393	0.02823	0.08786	0.05645
C1A	13.80	2000.0	50	03	0.02314	0.04622	0.02083	0.41595

Table 7-11—Example system synchronous motor data

Motor ID	Motor bus #	Rated kV	Rated kVA	Rated hp	r/min	X''_d (%)	X/R ratio
M-FDR-L	8	13.8	9000	9000	1800	20.0	34.0

Table 7-12—Example system induction motor data

Motor ID	Motor bus #	Total hp	Total kVA	r/min	Rated kV	X_M (%)	X/R ratio	Composition (hp)
M-30	51	200.0	200.0	1800	0.480	16.7	7.00	>50
M-31	51	600.0	570.0	1800	0.480	16.7	12.00	<50
M-T10-1	28	400.0	400.0	1800	0.480	16.7	10.00	<50
M-T10-2	28	500.0	500.0	1800	0.480	16.7	5.00	>50
M-T10-3	33	300.0	287.5	1800	0.480	16.7	12.00	<50
M-T11-1	29	625.0	625.0	1800	0.480	16.7	10.00	>50
M-T11-2	29	465.0	465.0	1800	0.480	16.7	5.00	<50
M-T11-3	34	110.0	110.0	1800	0.480	16.7	7.00	<50
M-T12-1	30	400.0	387.9	1800	0.480	16.7	12.00	>50
M-T12-2	30	500.0	500.0	1800	0.480	16.7	5.00	<50
M-T12-3	35	300.0	287.5	1800	0.480	16.7	12.00	<50
M-T13-1	36	2500.0	2250.0	1800	2.30	16.7	32.85	>50
M-T14-1	37	700.0	678.8	1800	0.480	16.7	12.00	>50
M-T14-2	37	300.0	300.0	1800	0.480	16.7	5.00	<50
M-T17-1	49	1250.0	1250.0	1800	0.460	33.0	10.00	>1000
M-T3-1	39	1750.0	1662.5	1800	4.160	16.7	29.74	>1000
M-T4-1	11	500.0	475.0	1800	2.400	16.7	12.00	>50
M-T5-1	17	850.0	824.2	1800	0.480	16.7	10.00	<50
M-T5-2	17	500.0	500.0	1800	0.480	16.7	5.00	>50
M-T5-3	22	150.0	142.5	1800	0.480	16.7	14.00	<50
M-T6-1	18	850.0	824.2	1800	0.480	16.7	10.00	<50
M-T6-2	18	500.0	500.0	1800	0.480	16.7	5.00	>50

Table 7-12—Example system induction motor data (Continued)

Motor ID	Motor bus #	Total hp	Total kVA	r/min	Rated kV	X_M (%)	X/R ratio	Composition (hp)
M-T6-3	23	150.0	142.5	1800	0.480	16.7	14.00	<50
M-T7-1	19	1250.0	1125.0	1800	2.400	16.7	26.10	>1000
M-T7-2	19	2500.0	2375.0	1800	2.400	16.7	15.00	>1000
M-T8-1	20	1750.0	1662.5	1800	2.400	16.7	15.00	>1000
M-T8-2	20	2000.0	1800.0	1800	2.400	28.0	26.00	>1000
M-T9-1	21	750.0	727.3	1800	0.480	16.7	12.00	<50

NOTE—The motor load M-T17-1 at bus 49 (RECT) signifies a dc rectifier load and has been modeled as an induction motor. The reactance was taken to be 33% (0.33 p.u.) considering the rated MVA of the associated converter transformer, in accordance with Internationally accepted recommendations. The dc rectifier load will be considered only for first-cycle simulation purposes and ignored for interrupting duty.

From bus #	To bus #	Crkt #	Impedances			From kV	To kV	Tap
			R(p.u.)	X(p.u.)	R(p.u.)			
1	3	1	.00313	.05324	0.0	69.00	13.800	1.00
2	4	1	.00313	.05324	0.0	69.00	13.800	1.00
5	39	1	.04314	.34514	0.0	13.80	4.160	1.00
5	49	1	.05918	.35510	0.0	13.80	.480	1.00
6	11	1	.05575	.36240	0.0	13.80	2.400	1.00
6	19	1	.01218	.14616	0.0	13.80	2.400	1.00
12	17	1	.06843	.44477	0.0	13.80	.480	1.00
13	18	1	.05829	.37888	0.0	13.80	.480	1.00
15	20	1	.01218	.14616	0.0	13.80	2.400	1.00
16	21	1	.15036	.75178	0.0	13.80	.480	1.00
25	28	1	.05829	.37888	0.0	13.80	.480	1.00
26	29	1	.05829	.37888	0.0	13.80	.480	1.00
27	30	1	.05829	.37888	0.0	13.80	.480	1.00

Figure 7-2—Positive sequence system branch data (p.u., 10 MVA)

From bus #	To bus #	Crkt #	Impedances			From kV	To kV	Tap
			R(p.u.)	X(p.u.)	R(p.u.)			
31	36	1	.02289	.22886	0.0	13.80	2.400	1.00
32	37	1	.10286	.56573	0.0	13.80	.480	1.00
50	51	1	.06395	.37796	0.0	13.80	.480	1.00
3	5	1	.00075	.00063	0.0			
3	6	1	.00109	.00091	0.0			
3	9	1	.00150	.00125	0.0			
3	26	1	.00157	.00131	0.0			
4	8	1	.00076	.00092	0.0			
4	15	1	.00227	.00189	0.0			
4	24	1	.00118	.00098	0.0			
4	16	1	.00274	.00229	0.0			
4	27	1	.00143	.00119	0.0			
9	12	1	.00038	.00032	0.0			
9	25	1	.00424	.00353	0.0			
10	13	1	.00046	.00039	0.0			
10	27	1	.00110	.00091	0.0			
17	22	1	.03813	.02451	0.0			
18	23	1	.03813	.02451	0.0			
24	31	1	.00079	.00065	0.0			
24	32	1	.00112	.00093	0.0			
28	33	1	.03813	.02451	0.0			
28	41	1	.03429	.02105	0.0			
29	34	1	.03813	.02451	0.0			
29	38	1	.08024	.07732	0.0			
29	38	2	.08024	.07732	0.0			
30	35	1	.03813	.02451	0.0			
50	3	1	.00243	.00485	0.0			
50	3	2	.00243	.00485	0.0			

Figure 7-2—Positive sequence system branch data (p.u., 10 MVA) (Continued)

From bus #	To bus #	Crkt #	Impedances			From kV	To kV	Tap
			R(p.u.)	X(p.u.)	R(p.u.)			
100	1	1	.00139	.00296	0.0			
100	2	1	.00139	.00296	0.0			

Figure 7-2—Positive sequence system branch data (p.u., 10 MVA) (Continued)

Both studies are needed for medium- and high-voltage breaker calculations (above 1kV) while only the first one is needed for low-voltage breakers (below 1 kV). The generator impedances utilized for the first cycle and interrupting duty studies are shown in Figure 7-3 (from Table 7-2). The motor impedances used for momentary and Interrupting calculations are shown in Figure 7-4 (from Table 7-2). It can be seen that small induction motors (individual motors or groups of motors composed from motors smaller than 50 hp) are neglected for interrupting duty calculations (Table 7-2).

Generator bus #	Bus kV	Generator impedances			
		R'_d	X'_d	R''_d	X''_d
4	13.80	0.003	0.102	0.003	0.102
50	13.80	0.002	0.072	0.002	0.072
100	69.00	0.000	0.010	0.000	0.010

Figure 7-3—Generator impedances for momentary and interrupting duty (p.u., 10 MVA)

Motor bus #	Bus kV	Motor		Motor MVA	Motor impedances			
		#	Type		R_{mom}	X_{mom}	R_{inter}	X_{inter}
11	2.40	1	IM	0.4750	0.352	4.219	0.879	10.547
17	0.48	1	IM	0.8242	0.338	3.384		
17	0.48	1	IM	0.5000	0.802	4.008	2.004	10.020
18	0.48	1	IM	0.8242	0.338	3.384		
18	0.48	1	IM	0.5000	0.802	4.008	2.004	10.020

Figure 7-4—Motor impedances for momentary and interrupting duty (p.u., 10 MVA)

Motor bus #	Bus kV	Motor		Motor MVA	Motor impedances			
		#	Type		R_{mom}	X_{mom}	R_{inter}	X_{inter}
19	2.40	1	IM	1.1250	0.057	1.484	0.085	2.227
19	2.40	1	IM	2.3750	0.047	0.703	0.070	1.055
20	2.40	1	IM	1.6625	0.067	1.005	0.100	1.507
20	2.40	1	IM	1.8000	0.060	1.556	0.090	2.333
21	0.48	1	IM	0.7273	0.320	3.835		
22	0.48	1	IM	0.1425	1.398	19.571		
23	0.48	1	IM	0.1425	1.398	19.571		
28	0.48	1	IM	0.5000	0.697	6.972		
28	0.48	1	IM	0.4000	0.802	4.008	2.004	10.020
29	0.48	1	IM	0.6250	0.321	3.206	0.802	8.016
29	0.48	1	IM	0.4650	1.199	5.998		
30	0.48	1	IM	0.3879	0.431	5.166	1.077	12.916
30	0.48	1	IM	0.5000	1.116	5.578		
33	0.48	1	IM	0.2875	0.809	9.701		
34	0.48	1	IM	0.1100	3.621	25.354		
35	0.48	1	IM	0.2875	0.809	9.701		
36	2.40	1	IM	2.2500	0.025	0.818	0.062	2.045
37	0.48	1	IM	0.6788	0.246	2.952	0.615	7.381
37	0.48	1	IM	0.3000	1.859	9.296		
39	4.16	1	IM	1.6625	0.034	1.005	0.051	1.507
49	0.48	1	IM	1.2500	0.264	2.640		
51	0.48	1	IM	0.2000	1.432	10.020	3.579	25.050
51	0.48	1	IM	0.5700	0.408	4.893		
8	13.80	1	SM	9.0000	0.006	0.222	0.010	0.333

Figure 7-4—Motor impedances for momentary and interrupting duty (p.u., 10 MVA) (Continued)

Typical information pertinent to first-cycle duty calculations is shown in Table 7-4. The symmetrical first cycle fault currents along with the total asymmetrical rms currents using the standard 1.6 multiplier (assuming an X/R ratio of 25 or less), as well as using the asymmetri-

cal multiplier, calculated from the actual system X/R ratio at the fault point. Similar information is shown for the peak currents. First-cycle asymmetrical fault currents are used to assess the closing and latching duty of medium- and high-voltage circuit breakers. These currents can be either total asymmetrical rms currents (ANSI C37.06-1979) or peak currents (ANSI Std C37.06-1987).

Typical information pertinent to interrupting duty calculations is shown in Figure 7-6. The same type of information as in Figure 7-5 is essentially displayed, except that in this case the multipliers applicable to both local and remote contributions are reported with reference to both breaker rating structures covered in IEEE Std C37.010-1979 and IEEE Std C37.5-1979. Total asymmetrical interrupting currents are also reported, thus yielding the interrupting requirements.

Fault at bus			Prefault				
#	ID	Zone	Voltage (kV)		Angle (degrees)		
19	T7SEC	5	2.40		0.00		
Current during fault				Voltage-to-ground during fault			
Type	p.u.	Degrees	Amperes	MVA	p.u.	Angle (degrees)	Module (kV)
LLL-A	7.67	-85.54	18 449	77	0.00	0.00	0.00
Equivalent impedance (p.u.)			X/R (IEEE Std C37.010-1979)		X_{eq} (IEEE Std C37.010-1979)		
ZQQ-1 = 0.0101 + j0.1300			13.69		0.1300		
Total asymmetrical first-cycle current							
Based on 1.6 multiplier (IEEE Std C37.010-1979)				Based on actual X/R ratio			
18 449 × 1.60 = 29 520 A				18 449 × 1.505 = 27 765 A			
Peak current							
Based on 2.7 multiplier				Based on actual X/R ratio			
18 449 × 2.70 = 49 812 A				18 449 × 2.541 = 46 879 A			
First ring contributions from:							
Bus			Prefault				
#	ID	Zone	Voltage (kV)		Angle (degrees)		
6	FDR-H 2	1	13.80		0.00		
Current during fault				Voltage-to-ground during fault			
Type	p.u.	Degrees	Amperes	MVA	p.u.	Angle (degrees)	Module (kV)
LLL-A	5.57	-85.11	13 418	56	0.82	-29.87	6.51
Transfer impedance (p.u.)							
ZQP-1 = 0.0021 + j0.0236							

Figure 7-5—Typical results for first cycle duty calculations

First ring contribution from:				
1 ind. motor(s) each rated 1.13 MVA				
Current during fault				
Type	p.u.	Degrees	Amperes	MVA
LLL-A	0.67	-87.81	1619	7
First ring contribution from:				
1 ind. motor(s) each rated 2.38 MVA				
Current during fault				
Type	p.u.	Degrees	Amperes	MVA
LLL-A	1.42	-86.19	3414	14

Figure 7-5—Typical results for first cycle duty calculations (Continued)

Fault at bus			Prefault				
#	ID	Zone	Voltage (kV)		Angle (degrees)		
10	EMERG	2	13.80		0.00		
Current during fault				Voltage-to-ground during fault			
Type	p.u.	Degrees	Amperes	MVA	p.u.	Angle (degrees)	Module (kV)
LLL-A	27.77	-83.05	11 616	278	0.00	0.00	0.00
Equivalent impedance (p.u.)				X/R (IEEE Std C37.010-1979)		X_{eq} (IEEE Std C37.010-1979)	
ZQ-1 = 0.0044 + j0.0358				8.950		0.0360	
Local and remote contribution from generating stations							
Local/total				Remote/total			
49.2%				50.8%			
Asymmetrical multipliers for 5 cycle breakers/3 cycles parting time (IEEE Std C37.010-1979)							
IEEE Std C37.010-1979 (local)		IEEE Std C37.010-1979 (remote)		IEEE Std C37.5-1979 (local)		IEEE Std C37.5-1979 (remote)	
1.00		1.00		1.00		1.00	
Total asymmetrical interrupting fault currents							
IEEE Std C37.010-1979 (weighted)		IEEE Std C37.010-1979 (remote)		IEEE Std C37.5-1979 (weighted)		IEEE Std C37.5-1979 (weighted)	
11619 A		11619 A		11619 A		11619 A	
First ring contributions from:							
Bus			Prefault				
#	ID	Zone	Voltage (kV)		Angle (degrees)		
13	T6PRI	1	13.80		0.00		

Figure 7-6—Typical results for interrupting duty calculations

Current during fault					Voltage-to-ground during fault		
Type	p.u.	Degrees	Amperes	MVA	p.u.	Angle (degrees)	Module (kV)
LLL-A	0.09	-78.76	39	1	0.0	00.00	0.00
Transfer impedance (p.u.)							
$Z_{QP-1} = 0.0021 + j0.0236$							
First ring contribution from:							
Bus			Prefault				
#	ID	Zone	Voltage (kV)		Angle (degrees)		
27	T12PRI	1	13.80		0.00		
Current during fault					Voltage-to-ground during fault		
Type	p.u.	Degrees	Amperes	MVA	p.u.	Angle (degrees)	Module (kV)
LLL-A	27.67	-83.07	11577	277	0.04	-43.47	0.32
Transfer impedance (p.u.)							
$Z_{QP-1} = 0.0033 + j0.0348$							

Figure 7-6—Typical results for interrupting duty calculations (*Continued*)

Typical computer-generated results for first-cycle (fault at 3:MILL-1) and interrupting duty (fault at 5:FDR-F) are shown in Figures 7-7 and 7-8, respectively, in both tabular and graphical form.

7.8 References

This standard shall be used in conjunction with the following publications:

ANSI C37.06-1979, American National Standard for Switchgear—AC High-Voltage Breakers Rated on a Symmetrical Current Basis—Preferred Ratings and Related Interrupting Capabilities.³

ANSI C37.06-1987, American National Standard Preferred Ratings and Related Interrupting Capabilities for AC High-Voltage Breakers Rated on a Symmetrical Current Basis.

AS 3851-1991, The calculation of short-circuit currents in three-phase a.c. systems.⁴

IEEE Std 141-1993, IEEE Recommended Practice for Electric Power Distribution for Industrial Plants (IEEE Red Book).

³IEEE and ANSI C37 publications are available from the Institute of Electrical and Electronics Engineers, 445 Hoes Lane, P.O. Box 1331, Piscataway, NJ 08855-1331, USA.

⁴AS publications are available from Standards Australia, P.O. Box 1055, Strathfield, NSW 2135, Australia.

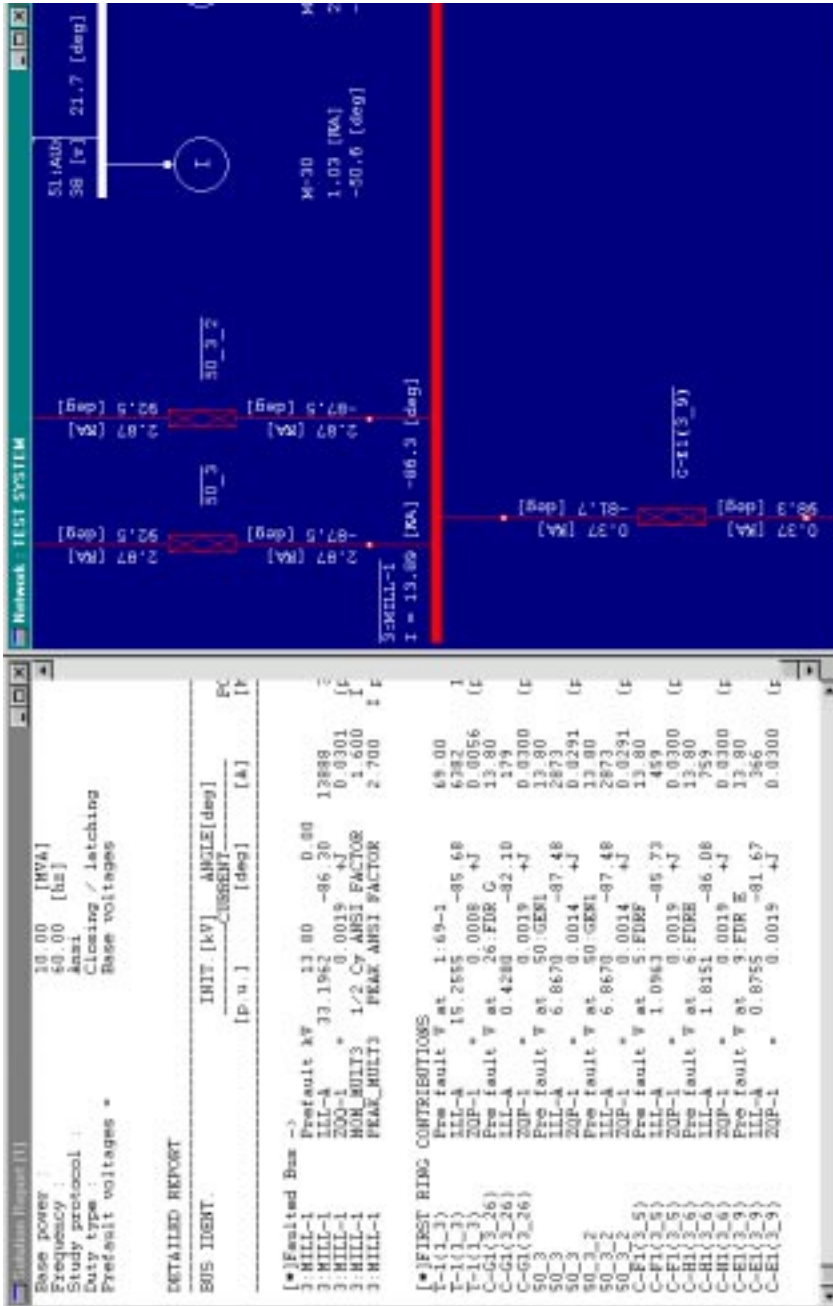

Figure 7-7—Typical computer reports for first-cycle duty calculations conformable to IEEE Std C37.010-1979

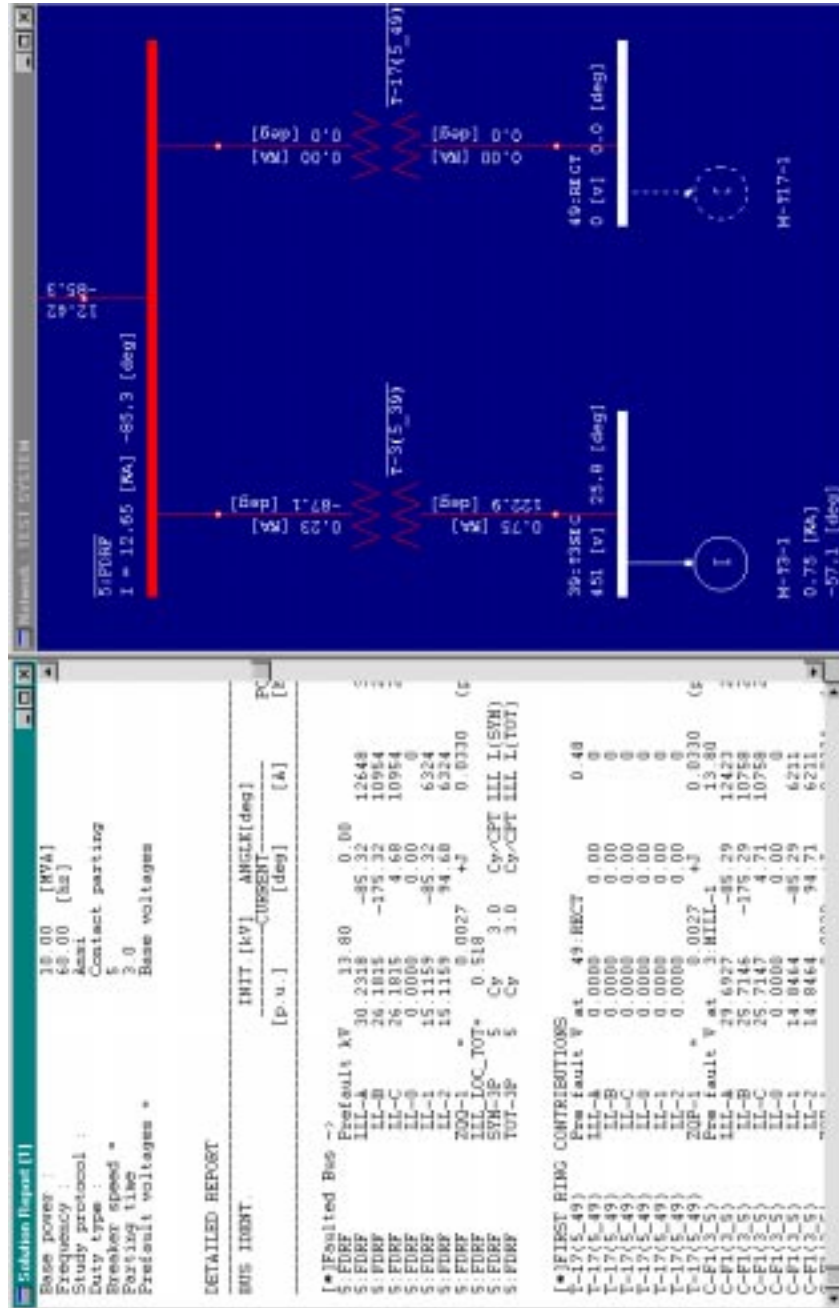

Figure 7-8—Typical computer reports for interrupting duty calculations conformable to IEEE Std C37.010-1979

IEEE Std 241-1990 (Reaff 1997), IEEE Recommended Practice for Electric Power Systems in Commercial Buildings (IEEE Gray Book).

IEEE Std 242-1986 (Reaff 1991), IEEE Recommended Practice for Protection and Coordination of Industrial and Commercial Power Systems (IEEE Buff Book).

IEEE Std C37.010-1979, IEEE Application Guide for AC High-Voltage Circuit Breakers Rated on a Symmetrical Current Basis (includes supplement Std C37.010d).

IEEE Std C37.5-1979, IEEE Guide for Calculation of Fault Currents for Application of AC High-Voltage Circuit Breakers Rated on a Total Current Basis.⁵

IEEE Std C37.13-1990, IEEE Standard for Low-Voltage AC Power Circuit Breakers Used in Enclosures.

VDE 0102, Recommendation for the Calculation of Short Circuit Currents, Part 1: Three Phase systems of voltages above 1 KV, Issued by the Deutsche Elektrotechnische Kommission, Frankfurt, Germany, 1972 (VDE).

IEC 60909 (1988), Short-circuit current calculation in three phase a.c. systems.⁶

7.9 Bibliography

[B1] Anderson, P., Analysis of Faulted Power Systems, IEEE Power System Engineering Series, Piscataway, NJ: IEEE Press, 1995.

[B2] Arrilaga J., Arnold, C. P, and Harker, B. J., *Computer Modelling of Electrical Power System*, New York: John Wiley & Sons, 1983.

[B3] Blackburn, L. J., *Symmetrical Components for Power Systems Engineering*, New York: Marcel Dekker, Inc., 1993.

[B4] Huening, W. C., Calculating short-circuit currents with contributions from induction motors, IEEE Transactions on Industry Applications, vol. IA-18, pp. 85–92, Mar./Apr. 1982.

[B5] Huening, W. C., Interpretation of new American National Standards for power circuit breaker applications. *IEEE Transactions on Industry and General Applications*, vol. IGA-5, Sep./Oct. 1969.

[B6] NFPA 70-1966, National Electric Code[®] (NEC[®]).

⁵This Standard has been withdrawn. Copies can be obtained from the IEEE Standards Department at (908) 562-3821.

⁶IEC publications are available from IEC Sales Department, Case Postale 131, 3, rue de Varembe, CH-1211, Genève 20, Switzerland/Suisse. IEC publications are also available in the United States from the Sales Department, American National Standards Institute, 11 West 42nd Street, 13th Floor, New York, NY 10036, USA.

- [B7] Rodolakis, A. J., A comparison of North American (ANSI) and European (IEC) Fault calculation guidelines, *IEEE Transactions on Industry Applications*, vol. 29, No. 3, pp. 515–521, May/June 1993.
- [B8] Roeper, R., *Short Circuit Currents in Three Phase Systems*, Siemens Actiengesellschaft, John Wiley & Sons, 1985.
- [B9] Stagg, G. W., and El-Abiad, A. H., *Computer Methods in Power System Analysis*, New York: McGraw-Hill, 1968.
- [B10] Stevenson, W. D., *Elements of Power System Analysis*, New York: McGraw-Hill, 1982.
- [B11] St. Pierre, C. R., *Time Sharing Computer Programs (DATUMS) for Power Data Reduction*. Schenectady, NY: General Electric Company, 1973.
- [B12] Tinney W., Brandwajn, V., and Chan, S., Sparse Vector Methods, *IEEE Transactions on Power Apparatus and Systems*, vol. PAS 104, pp. 295–301, Feb. 1985.
- [B13] Wagner, C. F., and Evans, R. D., *Symmetrical Components*, New York: McGraw-Hill, 1933.

Chapter 8

Stability studies

8.1 Introduction

For years, system stability was a problem almost exclusively to electric utility engineers. Small independent power producers (IPPs) and co-generation (co-gen) companies were treated as part of the load and modeled casually. Today, the structure of the utility industry is going through a revolutionary change under the process of deregulation. A full-scale competition in the generation market is on the horizon. Increasing numbers of industrial and commercial facilities have installed local generation, large synchronous motors, or both. The role of IPP/co-gen companies and other plants with on-site generation in maintaining system stability is a new area of interest in power system studies (Lee, Chen, and Williams [B20]).¹ When a co-generation plant (which, in the context of this chapter, is used in reference to any facility containing large synchronous machinery) is connected to the transmission grid, it changes the system configuration as well as the power flow pattern. This may result in stability problems both in the plant and the supplying utility (Flory et al. [B24]; Lee, Chen, and Williams [B21]). Figure 8-1 and Figure 8-2 are the time-domain simulation results of a system before and after the connection of a co-generation plant. (Lee, Chen, Gim et al. [B20]) The increased magnitude and decreased damping of machine rotor oscillations shown in these figures indicate that the system dynamic stability performance has deteriorated after the connection. This requires joint studies between utility and co-gen systems to identify the source of the problem and develop possible mitigation measures.

8.2 Stability fundamentals

8.2.1 Definition of stability

Fundamentally, stability is a property of a power system containing two or more synchronous machines. A system is stable, *under a specified set of conditions*, if, when subjected to one or more bounded disturbances (less than infinite magnitude), the resulting system response(s) are bounded. After a disturbance, a stable system could be described by variables that show continuous oscillations of finite magnitude (ac voltages and currents, for example) or by constants, or both. In practice, engineers familiar with stability studies expect that oscillations of machine rotors should be damped to an acceptable level within 6 s following a major disturbance. It is important to realize that a system that is stable by definition can still have stability problems from an operational point of view (oscillations may take too long to decay to zero, for example).

¹The numbers in brackets preceded by the letter B correspond to those of the bibliography in 8.9

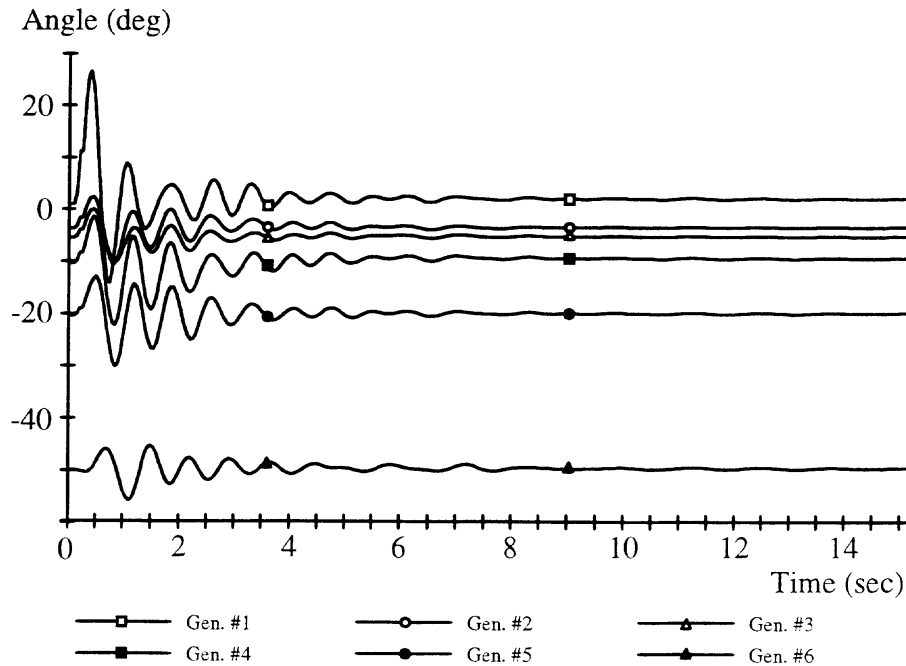

Figure 8-1—System response—No co-gen plant

8.2.2 Steady-state stability

Although the discussion in the rest of this chapter revolves around stability under transient and/or dynamic conditions, such as faults, switching operations, etc., there should also be an awareness that a power system can become unstable under steady-state conditions. The simplest power system to which stability considerations apply consists of a pair of synchronous machines, one acting as a generator and the other acting as a motor, connected together through a reactance (see Figure 8-3). (In this model, the reactance is the sum of the transient reactance of the two machines and the reactance of the connecting circuit. Losses in the machines and the resistance of the line are neglected for simplicity.)

If the internal voltages of the two machines are E_G and E_M and the phase angle between them is θ , it can easily be demonstrated that the real power transmitted from the generator to the motor is (Westinghouse [B2]; Fitzgerald and Kingsley, Jr. [B3]).

$$P = \frac{E_G E_M}{X} \sin \theta \quad (8-1)$$

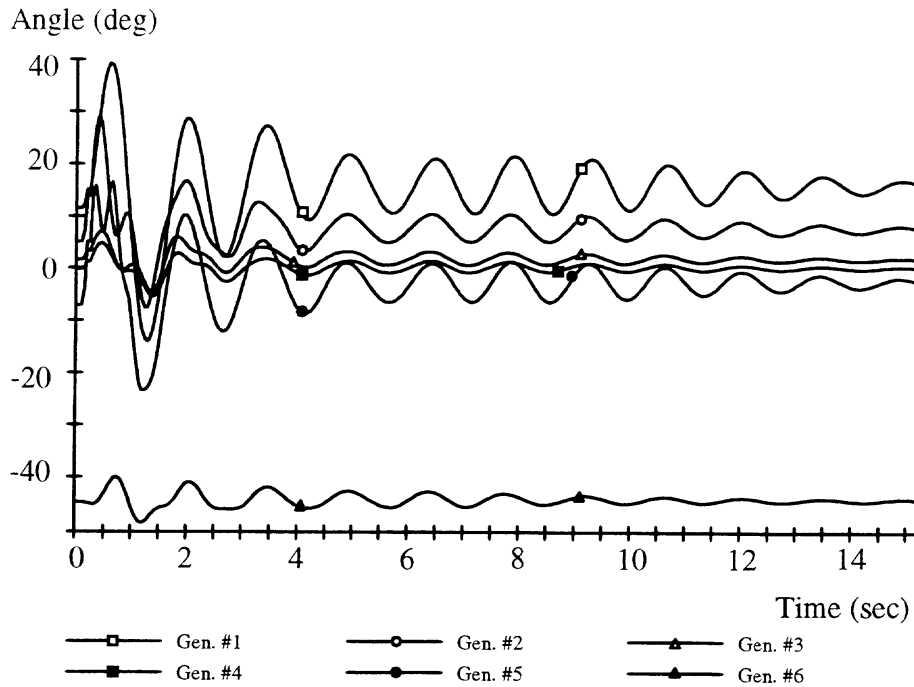

Figure 8-2—Low-frequency oscillation after the connection of the co-gen plant

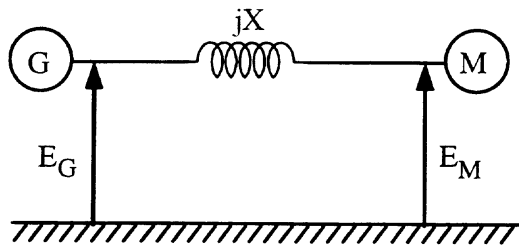

Figure 8-3—Simplified two-machine power system

The maximum value of P obviously occurs when $\theta = 90^\circ$. Thus

$$P_{\max} = \frac{E_G E_M}{X} \tag{8-2}$$

This is the steady-state stability limit for the simplified two-machine system. Any attempt to transmit more power than P_{\max} will cause the two machines to pull out of step (lose synchronism with each other) for particular values of internal voltages.

This simple example shows that at least three electrical characteristics of a power system affect stability. They are as follows:

- a) Internal voltage of the generator(s)
- b) Reactance(s) of the machines and transmission system
- c) Internal voltage of the motor(s), if any

The higher the internal voltages and the lower the system and machine reactances, the greater the power that can be transmitted under steady-state conditions.

8.2.3 Transient and dynamic stability

The preceding look at steady-state stability serves as a background for an examination of the more complicated problem of transient stability. This is true because the same three electrical characteristics that determine steady-state stability limits affect transient stability. However, a system that is stable under steady-state conditions is not necessarily stable when subjected to a transient disturbance.

Transient stability means the ability of a power system to experience a sudden change in generation, load, or system characteristics without a prolonged loss of synchronism. To see how a disturbance affects a synchronous machine, consider the steady-state characteristics described by the steady-state torque equation first (Kimbark [B14]).

$$T = \frac{\pi P^2}{8} \phi_{SR} F_R \sin \delta_R \quad (8-3)$$

where

- T is the mechanical shaft torque
- P is the number of poles of machine
- ϕ_{SR} is the air-gap flux
- F_R is the rotor field MMF
- δ_R is the mechanical angle between rotor and stator field lobes

The air-gap flux ϕ_{SR} stays constant as long as the internal voltage (which is directly related to field excitation) at the machine does not change and if the effects of saturation of the iron are neglected. Therefore, if the field excitation remains unchanged, a change in shaft torque T will cause a corresponding change in rotor angle δ_R . (This is the angle by which, for a motor, the peaks of the rotating stator field lead the corresponding peaks of the rotor field. For a generator, the relation is reversed.) Figure 8-4 graphically illustrates the variation of rotor angle with shaft torque. With the machine operating as a motor (when rotor angle and torque are positive), torque increases with rotor angle until δ_R reaches 90 electrical degrees. Beyond

90°, torque decreases with increasing rotor angle. As a result, if the required torque output of a synchronous motor is increased beyond the level corresponding to 90° rotor angle, it will *slip a pole*. Unless the load torque is reduced below the 90° level (the pullout torque), the motor will continue slipping poles indefinitely and is said to have lost synchronism with the supply system (and become unstable). The problems that can follow from extended operation in this out-of-step condition will be discussed further in this section.

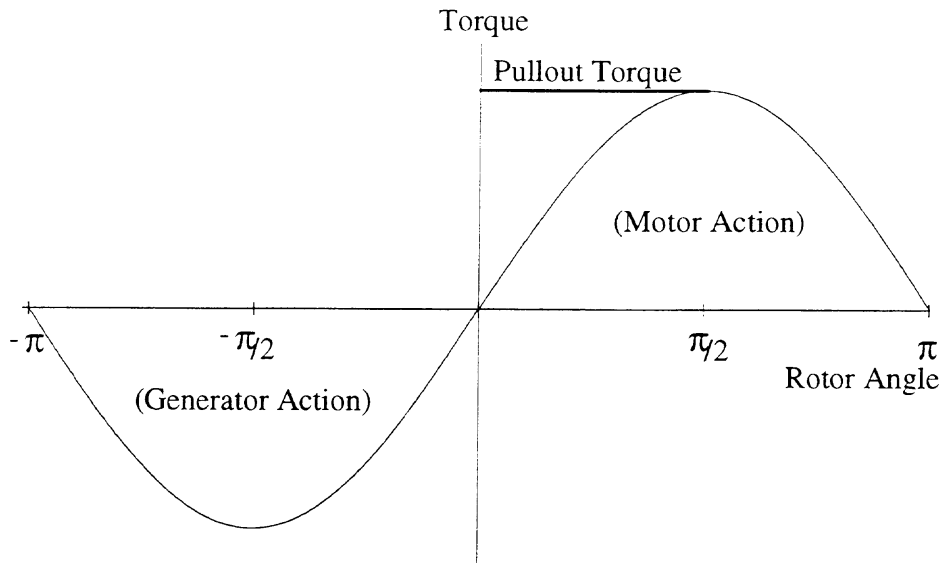

Figure 8-4—Torque vs. rotor angle relationship for synchronous machines in steady state

A generator operates similarly. Increasing torque input until the rotor angle exceeds 90° results in pole slipping and loss of synchronism with the power system, assuming constant electrical load.

Similar relations apply to the other parameters of the torque equation. For example, air-gap flux ϕ_{SR} is a function of voltage at the machine. Thus, if the other factors remain constant, a change in system voltage will cause a change in rotor angle. Likewise, changing the field excitation will cause a change in rotor angle if constant torque and voltage are maintained.

The preceding discussion refers to rather gradual changes in the conditions affecting the torque angle, so that approximate steady-state conditions always exist. The coupling between the stator and rotor fields of a synchronous machine, however, is somewhat elastic. This means that if an abrupt rather than a gradual change occurs in one or more of the parameters of the torque equation, the rotor angle will tend to overshoot the final value determined by the changed conditions. This disturbance can be severe enough to carry the ultimate steady-state

rotor angle past 90° or the transient *swing* rotor angle past 180° . Either event results in the slipping of a pole. If the conditions that caused the original disturbance are not corrected, the machine will then continue to slip poles; in short, pulling out of step or losing synchronism with the power system to which it is connected.

Of course, if the transient overshoot of the rotor angle does not exceed 180° , or if the disturbance causing the rotor swing is promptly removed, the machine may remain in synchronism with the system. The rotor angle then oscillates in decreasing swings until it settles to its final value (less than 90°). The oscillations are damped by electrical load and mechanical and electrical losses in the machine and system, especially in the damper windings of the machine.

A change in rotor angle of a machine requires a change in speed of the rotor. For example, if we assume that the stator field frequency is constant, it is necessary to at least momentarily slow down the rotor of a synchronous motor to permit the rotor field to fall farther behind the stator field and thus increase δ_R . The rate at which rotor speed can change is determined by the moment of inertia of the rotor plus whatever is mechanically coupled to it (prime mover, load, reduction gears, etc.). With all other variables equal, this means a machine with high inertia is less likely to become unstable given a disturbance of brief duration than a low-inertia machine.

Traditionally, *transient* stability is determined by considering only the inherent mechanical and electromagnetic characteristics of the synchronous machines and the impedance of the circuits connecting them. The responses of the excitation or governor systems to the changes in generator speed or electrical output induced by a system disturbance are neglected. On the other hand, *dynamic* stability takes automatic voltage regulator and governor system responses into account.

The traditional definition of transient stability is closely tied to the ability of a system to remain in synchronism for a disturbance. Transient stability studies are usually conducted under the assumptions that excitation and governor-prime mover time constants are much longer than the duration of the instability-inducing disturbance. This assumption was usually accurate when power system stability became a relevant problem in the 1920s (about the time that significant interconnections of systems became more common), because both the generator excitation voltage and the prime mover throttle were controlled either manually or by very slow feedback mechanisms, and brief short circuits were normally the worst-case disturbances considered.

However, technological advances have rendered the assumption underlying these conventional concepts of transient stability obsolete in most cases. These include the advent of fast electronic excitation systems and governors, the recognition of the value of stability analysis for investigating conditions of widely varying severity and duration, and the virtual elimination of computational power as a constraint on system modeling complexity. Most transient stability studies performed today consider at least the generator excitation system, and are therefore actually dynamic studies under the conventional conceptual definition.

8.2.4 Two-machine systems

The previous discussion of transient behavior of synchronous machines is based on a single machine connected to a good approximation of an infinite bus. An example is the typical industrial situation where a synchronous motor of at most a few thousand horsepower is connected to a utility company system with a capacity of thousands of megawatts. Under these conditions, we can safely neglect the effect of the machine on the power system.

A system consisting of only two machines of comparable size connected through a transmission link, however, becomes more complicated because the two machines can affect each other's performance. The medium through which this occurs is the air-gap flux. This is a function of machine terminal voltage, which is affected by the characteristics of the transmission system, the amount of power being transmitted, the power factor, etc.

In the steady state, the rotor angles of the two machines are determined by the simultaneous solution of their respective torque equations. Under a transient disturbance, as in the single-machine system, the rotor angles move toward values corresponding to the changed system conditions. Even if these new values are within the steady-state stability limits of the system, an overshoot can result in loss of synchronism. If the system can recover from the disturbance, both rotors will undergo a damped oscillation and ultimately settle to their new steady-state values.

An important concept here is synchronizing power. The higher the real power transfer capability over the transmission link between the two machines, the more likely they are to remain in synchronism in the face of a transient disturbance. Synchronous machines separated by a sufficiently low impedance behave as one composite machine, since they tend to remain in step with one another regardless of external disturbances.

8.2.5 Multimachine systems

At first glance, it appears that a power system incorporating many synchronous machines would be extremely complex to analyze. This is true if a detailed, precise analysis is needed; a sophisticated program is required for a complete stability study of a multimachine system. However, many of the multimachine systems encountered in industrial practice contain only synchronous motors that are similar in characteristics, closely coupled electrically, and connected to a high-capacity utility system. Under most type of disturbances, motors will remain in synchronism with each other, although they can all lose synchronism with the utility. Thus, the problem most often encountered in industrial systems is similar to a single synchronous motor connected through an impedance to an infinite bus. The simplification should be apparent. Stability analysis of more complex systems where machines are of comparable sizes and are separated by substantial impedance will usually require a full-scale computer stability study.

8.3 Problems caused by instability

The most immediate hazards of asynchronous operation of a power system are the high transient mechanical torque and currents that usually occur. To prevent these transients from causing mechanical and thermal damage, synchronous motors and generators are almost universally equipped with pullout protection. For motors of small to moderate sizes, this protection is usually provided by a damper protection of pullout relay that operates on the low power factor occurring during asynchronous operation. The same function is usually provided for large motors, generators, and synchronous condensers by loss-of-field relaying. In any case, the pullout relay trips the machine breaker or contactor. Whatever load is being served by the machine is naturally interrupted. Consequently, the primary disadvantage of a system that tends to be unstable is the probability of frequent process interruptions.

Out-of step operation also causes large oscillatory flows of real and reactive power over the circuits connecting the out-of-step machines. Impedance or distance-type relaying that protects these lines can falsely interpret power surges as a line fault, tripping the line breakers and breaking up the system. Although this is primarily a utility problem, large industrial systems or those where local generation operates in parallel with the utility can be susceptible.

In any of these cases, an industrial system can be separated from the utility system. If the industrial system does not have sufficient on-site generation, a proper load shedding procedure is necessary to prevent total loss of electrical power. Once separated from the strength of the utility, the industrial system becomes a rather weakly connected island and is likely to encounter additional stability problems. With the continuance of problems, protection systems designed to prevent equipment damage will likely operate, thus producing the total blackout.

8.4 System disturbances that can cause instability

The most common disturbances that produce instability in industrial power systems are (not necessarily in order of probability):

- a) Short circuits
- b) Loss of a tie circuit to a public utility
- c) Loss of a portion of on-site generation
- d) Starting a motor that is large relative to a system generating capacity
- e) Switching operations
- f) Impact loading on motors
- g) Abrupt decrease in electrical load on generators

The effect of each of these disturbances should be apparent from the previous discussion of stability fundamentals.

8.5 Solutions to stability problems

Generally speaking, changing power flow patterns and decreasing the severity or duration of a transient disturbance will make the power system less likely to become unstable under that disturbance. In addition, increasing the moment of inertia per rated kVA of the synchronous machines in the system will raise stability limits by resisting changes in rotor speeds required to change rotor angles.

8.5.1 System design

System design primarily affects the amount of synchronizing power that can be transferred between machines. Two machines connected by a low impedance circuit, such as a short cable or bus run, will probably stay synchronized with each other under all conditions except a fault on the connecting circuit, a loss of field excitation, or an overload. The greater the impedance between machines, the less severe a disturbance will be required to drive them out of step. For some systems, the dynamic stability problems could be resolved by the construction of new connecting circuits (Klein, Rogers, and Kundur [B15]). This means that from the standpoint of maximum stability, all synchronous machines should be closely connected to a common bus. Limitations on short-circuit duties, economics, and the requirements of physical plant layout usually combine to render this radical solution impractical.

8.5.2 Design and selection of rotating equipment

Design and selection of rotating equipment and control parameters can be a major contributor to improving system stability. Most obviously, use of induction instead of synchronous motors eliminates the potential stability problems associated with the latter. (Under rare circumstances, an induction motor/synchronous generator system can experience instability, in the sense that undamped rotor oscillations occur in both machines, but the possibility is too remote to be of serious concern.) However, economic considerations often preclude this solution.

Where synchronous machines are used, stability can be enhanced by increasing the inertia of the mechanical system. Since the H constant (stored energy per rated kVA) is proportional to the square of the speed, fairly small increases in synchronous speed can pay significant dividends in higher inertia. If carried too far, this can become self-defeating because higher speed machines have smaller diameter rotors. Kinetic energy varies with the square of the rotor radius, so the increase in H due to a higher speed may be offset by a decrease due to the lower kinetic energy of a smaller diameter rotor. Of course, specifications of machine size and speed are dependent on the mechanical nature of the application and these concerns may limit the specification flexibility with regard to stability issues.

A further possibility is to use synchronous machines with low transient reactances that permit the maximum flow of synchronizing power. Applicability of this solution is limited mostly by short-circuit considerations, starting current limitations, and machine design problems.

8.5.3 Voltage regulator and exciter characteristics

Voltage regulator and exciter characteristics affect stability because, all other things being equal, higher field excitation requires a smaller rotor angle. Consequently, stability is enhanced by a properly applied regulator and exciter that respond rapidly to transient effects and furnish a high degree of field forcing. In this respect, modern solid-state voltage regulators and static exciters can contribute markedly to improved stability. However, a mismatch in exciter and regulator characteristics can make an existing stability problem even worse (Demello and Concordia [B1]).

8.5.4 Application of power system stabilizers (PSSs)

The PSS installation has been widely used in the power industry to improve the system damping. The basic function of a PSS is to extend stability limits by modulating generator excitation to provide damping to the oscillation of a synchronous machine rotor. To provide damping, the PSS must produce a component of electrical torque on the rotor that is in phase with speed variations. The implementation details differ, depending upon the stabilizer input signal employed. However, for any input signal, the transfer function of the stabilizer must compensate for the gain and phase characteristics of the excitation system, the generator, and the power system, which collectively determine the transfer function from the stabilizer output to the component of electrical torque, which can be modulated via excitation control. To install the PSS in the power system to solve the dynamic stability problem, one has to determine the installation site and the settings of PSS parameters. This job can be realized through frequency domain analysis (Fretwell, Lam, and Yu [B5]; Klein, Rogers, Moorty et al. [B16]; Kundur, Klein, Roger et al. [B17]; Kundur, Lee, and Zein El-Din [B18]; Larsen and Swann [B19]; Martin and Lima [B22]).

8.5.5 System protection

System protection often offers the best prospects for improving the stability of a power system. The most severe disturbance that an industrial power system is likely to experience is a short circuit. To prevent loss of synchronism, as well as to limit personnel hazards and equipment damage, short circuits should be isolated as rapidly as possible. A system that tends to be unstable should be equipped with instantaneous overcurrent protection on all of its primary feeders, which are the most exposed section of the primary system. As a general rule, instantaneous relaying should be used throughout the system wherever selectivity permits.

8.6 System stability analysis

Stability studies, as much or more than any other type of power system study described in this text, have benefited from the advent of the computer. This is primarily due to the fact that stability analysis requires a tremendous number of iterative calculations and the manipulation of a large amount of time and frequency-variant data.

8.6.1 Time- and frequency-domain analysis

Time and frequency-domain (eigenvalue analysis) techniques are, by far, the most common analytical methods used by power system stability programs. Time-domain analysis utilizes the angular displacement of the rotors of the machines being studied, often with respect to a common reference, to determine stability conditions. The differences between these rotor angles are small for stable systems. The rotor angles of machines in unstable systems drift apart with time. Thus, time-domain analysis can be used to determine the overall system response to potentially instability-inducing conditions, but it is limited when one is attempting to identify oscillation modes.

Frequency-domain analysis, on the other hand, can be used to identify each potential oscillation frequency and its corresponding damping factor. Therefore, the powerful frequency-domain techniques are particularly suited for dynamic stability applications whereas time-domain techniques are more useful in transient stability analysis. Fortunately, dynamic stability can also be evaluated by the shapes of the swing curves of synchronous machine rotor angles as they vary with time. Therefore, time-domain analysis can be used for dynamic stability as well, and it will be the analytical technique on which the remainder of this chapter will be focused.

8.6.2 How stability programs work

Mathematical methods of stability analysts depend on a repeated solution of the swing equation for each machine:

$$P_a = \frac{(MVA)H}{180f} \frac{d^2\delta_R}{dt^2} \quad (8-4)$$

where

- P_a is the accelerating power (input power minus output power) (MW)
- MVA is the rated MVA of machine
- H is the inertia constant of machine (MW·seconds/MVA)
- f is the system frequency (Hz)
- δ_R is the rotor angle (degrees)
- t is the time (seconds)

The program begins with the results of a load flow study to establish initial power and voltage levels in all machines and interconnecting circuits. The specified disturbance is applied at a time defined as zero, and the resulting changes in power levels are calculated by a load flow routine. Using the calculated accelerating power values, the swing equation is solved for a new value of δ_R for each machine at an incremental time (the incremental time should be less than one-tenth of the smallest machine time constant to limit numerical errors) after the disturbance. Voltage and power levels corresponding to the new angular positions of the synchronous machines are then used as base information for next iteration. In this way, performance of the system is calculated for every interval out to as much as 15 s.

8.6.3 Simulation of the system

A modern transient stability computer program can simulate virtually any set of power system components in sufficient detail to give accurate results. Simulation of rotating machines and related equipment is of special importance in stability studies. The simplest possible representation for a synchronous motor or generator involves only a constant internal voltage, a constant transient reactance, and the rotating inertia (H) constant. This approximation neglects saturation of core iron, voltage regulator action, the influence of construction of the machine on transient reactance for the direct and quadrature axes, and most of the characteristics of the prime mover or load. Nevertheless, this *classical* representation is often accurate enough to give reliable results, *especially* when the time period being studied is rather short. (Limiting the study to a short period—say, 1/2 s or less, means that neither the voltage regulator nor the governor, if any, has time to exert a significant effect.) The *classical* representation is generally used for the smaller and less influential machines in a system, or where the more detailed information required for better simulations is not available.

As additional data on the machines becomes available, better approximations can be used. This permits more accurate results that remain reliable for longer time periods. Modern large-scale stability programs can simulate all of the following characteristics of a rotating machine:

- a) Voltage regulator and exciter
- b) Steam system or other prime mover, including governor
- c) Mechanical load
- d) Damper windings
- e) Salient poles
- f) Saturation

Induction motors can also be simulated in detail, together with speed-torque characteristics of their connected loads. In addition to rotating equipment, the stability program can include in its simulation practically any other major system component, including transmission lines, transformers, capacitor banks, and voltage-regulating transformers and dc transmission links in some cases.

8.6.4 Simulation of disturbances

The versatility of the modern stability study is apparent in the range of system disturbances that can be represented. The most severe disturbance that can occur on a power system is usually a three-phase bolted short circuit. Consequently, this type of fault is most often used to test system stability. Stability programs can simulate a three-phase fault at any location, with provisions for clearing the fault by opening breakers either after a specified time delay, or by the action of overcurrent, underfrequency, overpower, or impedance relays. This feature permits the adequacy of proposed protective relaying to be evaluated from the stability standpoint.

Short circuits other than the bolted three-phase fault cause less disturbance to the power system. Although most stability programs cannot directly simulate line-to-line or ground faults, the effects of these faults on synchronizing power flow can be duplicated by applying a three-phase fault with a *properly* chosen fault impedance. This means the effect of any type of fault on stability can be studied.

In addition to faults, stability programs can simulate switching of lines and generators. This is particularly valuable in the load-shedding type of study, which will be covered in a following section. Finally, the starting of large motors on relatively weak power systems and impact loading of running machines can be analyzed.

8.6.5 Data requirements for stability studies

The data required to perform a transient stability study and the recommended format for organizing and presenting the information for most convenient use are covered in detail in the application guides for particular stability programs. The following is a summary of the generic classes of data needed. Note that some of the more esoteric information is not essential; omitting it merely limits the accuracy of the results, especially at times exceeding five times the duration of the disturbance being studied. The more essential items are marked by an asterisk (*).

- a) System data
 - 1) Impedance ($R + jX$) of all significant transmission lines, cables, reactors, and other series components*
 - 2) For all significant transformers and autotransformers
 - i) kVA rating*
 - ii) Impedance*
 - iii) Voltage ratio*
 - iv) Winding connection*
 - v) Available taps and tap in use*
 - vi) For regulators and load tap-changing transformers: regulation range, tap step size, type of tap changer control*
 - 3) Short-circuit capacity (steady-state basis) of utility supply, if any*
 - 4) kvar of all significant capacitor banks*
 - 5) Description of normal and alternate switching arrangements*
- b) Load data: real and reactive electrical loads on all significant load buses in the system*
- c) Rotating machine data
 - 1) For major synchronous machines (or groups of identical machines on a common bus)
 - i) Mechanical and/or electrical power ratings (kVA, hp, kW, etc.)*
 - ii) Inertia constant H or inertia Wk^2 of rotating machine and connected load or prime mover*
 - iii) Speed*
 - iv) Real and reactive loading, if base-loaded generator*
 - v) Speed torque curve or other description of load torque, if motor*
 - vi) Direct-axis subtransient,* transient,* and synchronous reactances*

- vii) Quadrature-axis subtransient, transient,* and synchronous reactances
 - viii) Direct-axis and quadrature-axis subtransient and transient* time constants
 - ix) Saturation information
 - x) Potier reactance
 - xi) Damping data
 - xii) Excitation system type, time constants, and limits
 - xiii) Governor and steam system or other prime mover type, time constants, and limits
- 2) For minor synchronous machines (or groups of machines)
 - i) Mechanical and/or electrical power ratings*
 - ii) Inertia*
 - iii) Speed*
 - iv) Direct-axis synchronous reactance*
 - 3) For major induction machines or groups of machines
 - i) Mechanical and/or electrical power ratings*
 - ii) Inertia*
 - iii) Speed*
 - iv) Positive-sequence equivalent circuit data (e.g., R_1 , X_1 , X_M)*
 - v) Load speed-torque curve*
 - vi) Negative-sequence equivalent circuit data (e.g., R_2 , X_2)*
 - vii) Description of reduced-voltage or other starting arrangements, if used*
 - 4) For small induction machines: detailed dynamic representation not needed, represent as a static load
- d) Disturbance data
 - 1) General description of disturbance to be studied, including (as applicable) initial switching status; fault type, location, and duration; switching operations and timing; manufacturer, type, and setting of protective relays; and clearing time of associated breakers*
 - 2) Limits on acceptable voltage, current, or power swings*
 - e) Study parameters
 - 1) Duration of study*
 - 2) Integrating interval*
 - 3) Output printing interval*
 - 4) Data output required*

8.6.6 Stability program output

Most stability programs give the user a wide choice of results to be printed out. The program can calculate and print any of the following information as a function of time under time domain analysis:

- a) Rotor angles, torques, and speeds of synchronous machines
- b) Real and reactive power flows throughout the system
- c) Voltages and voltage angles at all buses
- d) Bus frequencies
- e) Torques and slips of all induction machines

The combination of these results selected by the user can be printed out for each printing interval (also user selected) during the course of the study period.

The value of the study is strongly affected by the selection of the proper printing interval and the total duration of the simulation. Normally, a printing interval of 0.01 or 0.02 s is used; longer intervals reduce the solution time slightly, but increase the risk of missing fast swings of rotor angle. The time required to obtain a solution is proportional to the length or the period being studied, so this parameter should be closely controlled for the sake of economy.

Avoiding long study periods is especially important if the system and machines have been represented approximately or incompletely because the errors will accumulate and render the results meaningless after some point. A time limit of five times the duration of the major disturbance being studied is generally long enough to show whether the system is stable (in the transient stability sense) or not, while keeping solution time requirements to reasonable levels.

Frequency domain analysis will calculate the eigenvalues to determine the stability characteristics of the system. For a large utility system, most programs can only provide dominant eigenvalue(s) of the system. This information is sufficient for most stability studies except multi-dominant eigenvalues situations.

8.6.7 Interpreting results

The results of a computer stability study are fairly easy to understand once the user learns the basic principles underlying stability problems. The most direct way to determine from study results whether a system is stable is to look at a set of swing curves for the machines in the system. Swing curves are simply plots of rotor angles or machine frequencies (rotor speeds) versus time; if the curves of all the machines involved are plotted on common axes, we can easily see whether they diverge (indicating instability) or settle to new steady-state values. Even if the system is stable, a poor damping situation is not acceptable from the security operation point of view. As previously mentioned, most utility engineers expect that any oscillations should be damped to an acceptable value within 6 s. The system responses, as shown in both Figure 8-1 and Figure 8-5, have good damping factors, and the system returns to normal within a reasonable time frame. However, the situation depicted in Figure 8-2 is considered marginal, even though the system is still stable by definition (oscillations are clearly bounded). In a frequency domain analysis of this same system, one can expect that all the eigenvalues of the system should lie in the left-half of the s-plane, and most utility engineers consider that the real part of the dominant eigenvalues should be less than -0.2 to -0.3 (time constant is between 3.33 to 5 s) for a normal power system. The time domain responses for various root locations in the frequency domain are shown in Figure 8-6.

8.7 Stability studies of industrial power systems

The requirement of stability studies depends on the operating conditions of the industrial power systems. This subclause is intended to summarize the so-called “things to look for” under different operating conditions and disturbance scenarios.

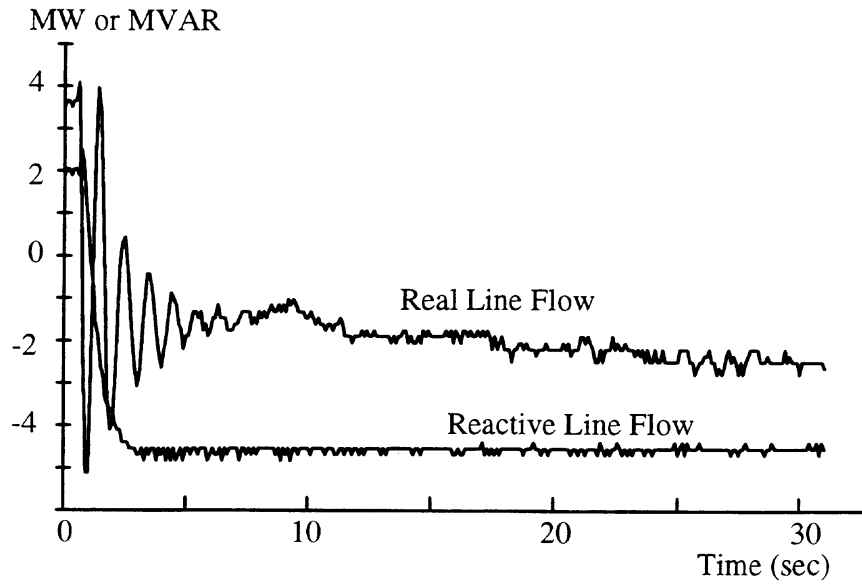

Figure 8-5—Oscillation record of the tie line between co-gen and utility

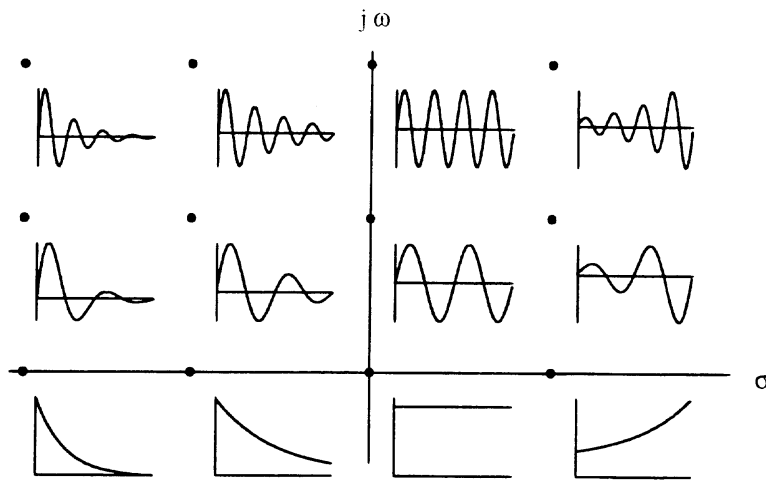

Figure 8-6—The response for various root locations in the frequency domain

8.7.1 A co-gen plant with excess generation

Consider the situation where a co-gen plant is exporting power to the connected utility company when a severe disturbance occurs. If the tie line(s) between co-gen and utility company are tripped, the co-gen facility becomes islanded. Because the plant has enough generation to support its own operation, stability problems within the facility are less likely to happen. However, the following should be checked to ensure secure operation.

- a) *Transient stability problem.* Generally speaking, the inertia of the co-gen units are smaller than the utility generators. They tend to respond faster to a system disturbance. If the fault happens in the vicinity of the plant and is not cleared before the critical clearing time, the speed of the units inside the plant may increase rapidly and the units may lose synchronism. Figure 8-7 illustrates this phenomena. A faster circuit breaker can be used to avoid this problem.

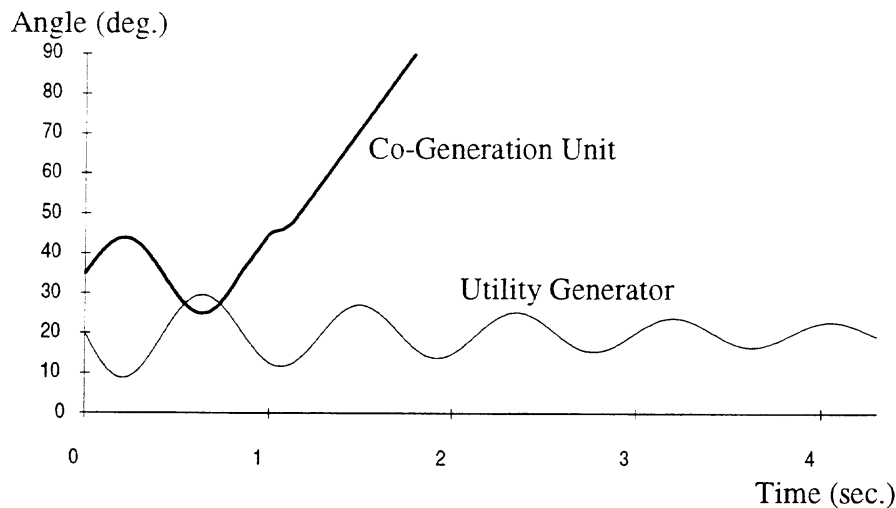

Figure 8-7—Out-of-step phenomenon of co-gen unit(s) under severe disturbance

- b) *Potential overfrequency.* Because the plant has excess power before islanding occurs, the frequency within the co-gen plant will rise after the interruption. The exact extent of the frequency deviation depends on the level of excess power and the response of the machine governors.
- c) *Voltage problems.* If the co-gen facility exports reactive power before the disturbance, the system may experience overvoltage phenomena following the separation. On the contrary, if the co-gen facility is importing reactive power, then an undervoltage problem may arise. The ability to overcome the voltage problems depends on the response of the automatic voltage regulators (AVRs) within the plant.

- d) *In-plant oscillations.* For some co-gen plants, a series reactor is inserted in the line to limit the fault currents. This may cause the generators to be loosely coupled from the electrical standpoint, even though are physically located within a plant. During the disturbance, two generators within the plant may experience oscillations often called hunting. Figure 8-8 shows a typical hunting oscillation of two generators. One can see that the output of the generators are basically out-of-phase.

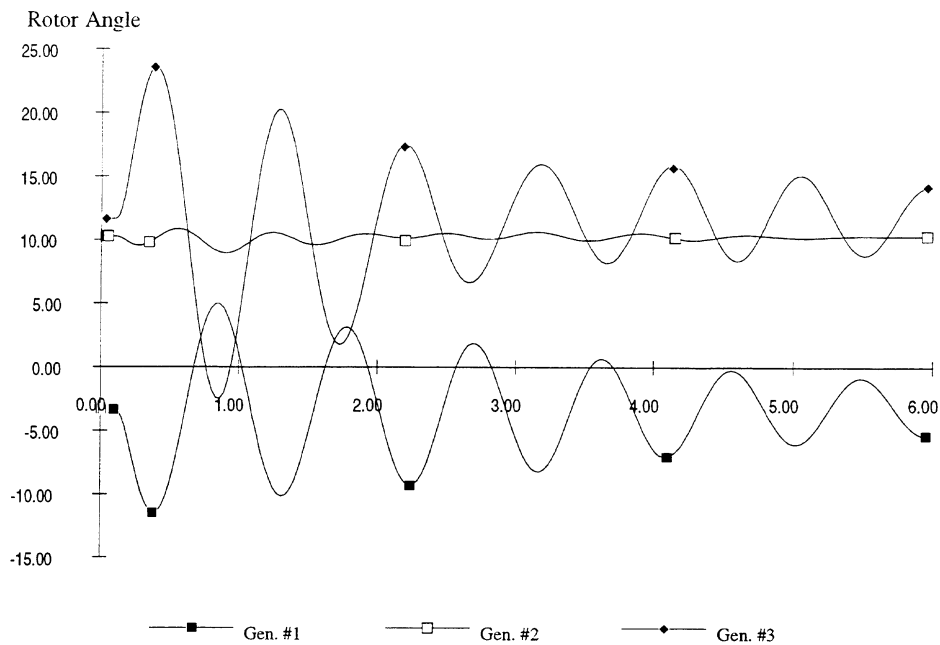

Figure 8-8—Hunting phenomena of two generator units

8.7.2 Co-gen plant that imports power from local utility

A co-gen plant relies on the supply from the local utility under normal operating conditions and the tie line(s) between the plant and the utility company are interrupted due to a system fault. Because the plant does not have enough generation to support its own operation, stability problems may happen. In order to protect the system from total blackout, an appropriate load shedding procedure has to be in place for safe operation. The following problems may happen under this scenario.

- a) *Potential underfrequency.* Because the co-gen plant has to import power before islanding, the frequency within the co-gen plant will decline after the interruption. The exact extent of the frequency deviation depends on the level of the power deficiency and the response of the machine governors. A proper load-shedding procedure may be needed to maintain continuing operation of critical loads.

- b) *Voltage problems.* When the load-shedding procedure is activated, a certain percentage of the real and reactive power are interrupted. The plant may face potential over-voltage problems. The situation may be compounded if the plant is exporting reactive power before islanding.
- c) *In-plant oscillation.* Similar to 8.7.1, especially if the co-gen plant uses series reactors to limit the fault currents. A potential in-plant oscillation may occur.

8.7.3 Oscillations between industrial power plant and utility system

The causes of low-frequency oscillation phenomena in a power system are complex. If the capacity of the industrial power plant is small compared to the connected utility system, the likelihood of having oscillations between industrial plant and utility system is generally very small. However, if the size of the industrial power plant is comparable to the capacity of the local utility, a detailed simulation including both the industrial power plant and the local utility has to be performed to ensure secure operation of the system. The system structure, operation conditions, and excitation systems frequently play important roles in low-frequency oscillation. It is necessary to distinguish the causes and the reasons before trying to solve the problem. In time domain analysis, the mode of oscillation cannot be identified exactly, but the potential oscillation phenomena can be investigated. The following steps can be considered as standard procedure to identify the possible causes of the low-frequency oscillation.

8.7.3.1 Response of the system before connection

The first step is to identify whether the dynamic stability problem is a pre-existing problem. If the problem exists before the connection, it is the responsibility of the utility to solve the problem. However, the plant still needs to provide information for detailed system analysis including specifics regarding on-site generation.

8.7.3.2 Different line flow between utility and co-gen plant

As a rule of thumb, the stability limit is the upper bound of the transfer capability of the interconnecting line(s) and transformer(s). The system is going to have stability problems if the transfer limits exceed this value. Therefore, the least-cost step is to investigate the possible solution(s) for low-frequency oscillation by adjusting the power flow of the interconnecting equipment.

8.7.3.3 Reduced impedance of the interconnected transmission

A system is less likely to have stability problems if the generators are electrically close together. Sometimes the stability problem will go away after the construction of a new transmission line, the reconfiguration of the utility supply, or some other system change. Lowering system impedances will reduce the electrical distance of the generation units and establish a stronger tie between co-gen and utility systems. The effectiveness of reducing impedances to increase system stability can be determined easily using modern computer programs.

8.7.3.4 Reduce fault clearing time

The longer a disturbance is on the system, the larger the frequency deviation and the phase angle separation can be. Therefore, fault duration may effect the recovery capability of the system after a severe disturbance. With today's technology, high-speed relays and breakers are available to clear the fault within a few cycles. This is an effective method of dealing with many transient stability problems.

8.7.3.5 System separation

Though this is not the most favorable solution, it is an effective measure to mitigate the problem if it appeared after the connection of both systems. However, if the utility imports power from the co-gen plant before the disturbance, system separation means loss of generation capacity. This may compound the problem on the utility side and should therefore be studied carefully.

8.7.3.6 Installation of a power system stabilizer (PSS)

The PSS installation has been widely used in the power industry to improve the system damping. To install the PSS in the power system to solve the dynamic stability problem, one has to determine the installation site and the setting of PSS parameters. This job can be realized through frequency domain analysis. The basic function of a PSS is to extend stability limits by modulating generator excitation to provide damping to the oscillation of a synchronous machine rotor. Since site selection and setting of a PSS are very sensitive to the system parameters, accuracy of the system information is vital in this type of study.

8.8 Summary and conclusions

Power systems are highly nonlinear and the dynamic characteristic of a power system varies if the system loading, generation schedule, network interconnection, and/or type of system protection are changed. When a co-gen plant is connected to the utility grid, it changes the system configuration and power flow pattern in the utility. This may result in some unwanted system stability problems from low-frequency oscillations. The evaluation of potential problems and solution methods prior to the connection of the co-gen plant becomes a challenging task for the power engineer.

From the industrial power plant point of view, stability problems appear as over/under voltages and frequencies and may lead to the operation of protection equipment and the initiation of load-shedding schemes. While there is no single way to design a system that will always remain stable, the use of low-impedance interconnections (where possible considering fault duties) and fast-acting control systems are definite options to consider when designing for maximum stability. It is important to consider problems that could originate in either the utility or industrial system, or both, and the impact of subsequent disturbances that are associated with protective device operation and load-shedding initiated by the original event.

8.9 Bibliography

[B1] Demello, F. P., and Concordia, C., "Concept of synchronous machine stability as affected by excitation control," *IEEE Transactions on Power Apparatus and System*, vol. PAS-88, no. 4, pp. 316–329, Apr. 1969.

[B2] *Electrical Transmission and Distribution Reference Book*, Westinghouse Electric Corporation, East Pittsburgh, PA, 1964, Chapter 13.

[B3] Fitzgerald, A. E., and Kingsley Jr., C., *Electric Machinery*, New York: McGraw-Hill, 1961, Chapter 5.

[B4] Flory, J. E., Key, T. S., Smith, W. M., et al., "The electric utility—industrial user partnership in solving power quality problems," *IEEE Transaction on Power Systems*, vol. 5, Aug. 1990.

[B5] Fretwell, A., Lam, D. M., Yu, C. Y., et al., "Design, Installation and Operation of Power System Stabilizers on the Hong Kong Electric Power System," *IEE International Conference on Advances in Power System Control, Operation and Management*, pp. 534–541, Hong Kong, Nov. 1991.

[B6] Gim, J. H., "Dynamic characteristic analysis and real time monitoring system for an industrial power system," Dissertation, The University of Texas at Arlington, Dec. 1993.

[B7] IEEE Committee Report, "Computer representation of excitation systems," *IEEE Transactions on Power Apparatus and System*, vol. PAS-87, no.6, pp. 1460–1464, June 1968.

[B8] IEEE Committee Report, "Current usage and suggested practices in power system stability simulations for synchronous machines," *IEEE Transactions on Energy Conversion*, vol. EC-1, pp. 77–93, Mar. 1986.

[B9] IEEE Committee Report, "Dynamic models for fossil fueled steam units in power system studies," *IEEE Transactions on Power Systems*, vol. 6, no. 2, pp. 753–761, May 1991.

[B10] IEEE Committee Report, "Dynamic models for steam and hydro turbines in power system studies," *IEEE Transaction on Power Apparatus and System*, vol. 92, no. 6, pp. 1904–1915, Nov./Dec. 1973.

[B11] IEEE Committee Report, "Excitation system models for power system stability studies," *IEEE Transactions on Power Apparatus and System*, vol. PAS-100, no. 2, pp. 494–509, Feb. 1981.

[B12] IEEE Std 421.5-1992, IEEE Recommended Practice for Excitation System for Power Stability Studies.

[B13] IEEE Std 1110-1991, IEEE Guide for Synchronous Generator Modeling Practices in Stability Analysis.

- [B14] Kimbark, E. W., "Power System Stability," vol. 1, New York: John Wiley, 1948.
- [B15] Klein, M., Rogers, G. J., and Kundur, P., "A fundamental study of inter-area oscillation in power system," *IEEE Transactions on Power Systems*, vol. 6, no. 3, pp. 914–921, Aug. 1991.
- [B16] Klein, M., Rogers, G. J., Moorty, S., et al., "Analytical investigation of factors influencing power system stabilizer performance," *IEEE Transactions on Energy Conversion*, 92 WM 016-6EC.
- [B17] Kundur, P., Klein, M., Roger, G. J., et al., "Application of power system stabilizers for enhancement of overall system stability" *IEEE Transactions on Power Systems*, vol. 4, no. 2, pp. 614–626, May 1989.
- [B18] Kundur, P., Lee, D. C., and Zein El-Din, H. M., "Power system stabilizer for thermal units: analytical techniques and on-site validation," *IEEE Transactions on Power Apparatus and System*, vol. PAS-100, no. 1, pp. 81–95, Jan. 1981.
- [B19] Larsen, E. V., and Swann, D. A., "Applying power system stabilizer, Part I: General concept," *IEEE Transactions on Power Apparatus and Systems*, vol. PAS-100, no. 6, pp. 3017–3024, June 1981.
- [B20] Lee, W. J., Chen, M. S., Gim, Y. H., et al., "Dynamic stability analysis of an industrial power system," *IEEE-IAS Annual Conference*, pp. 1477–1482, Oct. 1993.
- [B21] Lee, W. J., Chen, M. S., and Williams, L. B., "Load model for stability studies," *IEEE Transactions on Industry Applications*, vol. IA-23, no. 1, Jan./Feb. 1987.
- [B22] Martin, N., and Lima, L. T. G., "Determination of suitable locations for power system stabilizer and static var compensators for damping electromechanical oscillations in large scale power system," *IEEE PICA*, Seattle, WA, pp. 358–365, May 1989.
- [B23] Park, R. H., "Two-reaction theory of synchronous machine," *AIEE Transactions, Part I*, vol. 48, pp. 716–730, 1929, Part II, vol. 52, pp. 352–55, 1933.

Chapter 9

Motor-starting studies

9.1 Introduction

This chapter discusses benefits obtained from motor-starting studies and examines various types of computer-aided studies normally involved in motor-starting studies. Data or information required for these studies as well as the expected results of a motor-starting study effort are also reviewed.

9.2 Need for motor-starting studies

9.2.1 Problems revealed

Motors on modern industrial systems are becoming increasingly larger. Some are considered large even in comparison to the total capacity of large industrial power systems. Starting large motors, especially across-the-line, can cause severe disturbances to the motor and any locally connected load, and also to buses electrically remote from the point of motor starting. Ideally, a motor-starting study should be made before a large motor is purchased. A starting voltage requirement and preferred locked-rotor current should be stated as part of the motor specification. A motor-starting study should be made if the motor horsepower exceeds approximately 30% of the supply transformer(s) base kVA rating, if no generators are present. If generation is present, and no other sources are involved, a study should be considered whenever the motor horsepower exceeds 10–15% of the generator kVA rating, depending on actual generator characteristics. The study should also recognize contingent condition(s), i.e., the loss of a source (if applicable).

It may be necessary to make a study for smaller horsepower sizes depending on the daily fluctuation of nominal voltage, voltage level, size and length of the motor feeder cable, amount of load, regulation of the supply voltage, the impedance and tap ratio of the supply transformer(s), load torque versus motor torque, and the allowable starting time. Finally, some applications may involve starting large groups of smaller motors of sufficient collective size to impact system voltage regulation during the starting interval.

A brief discussion of major problems associated with starting large motors, or groups of motors, and therefore, of significance in power system design and evaluation follows.

9.2.2 Voltage dips

Probably the most widely recognized and studied effect of motor-starting is the voltage dip experienced throughout an industrial power system as a direct result of starting large motors. Available accelerating torque drops appreciably at the motor bus as voltage dips to a lower value, extending the starting interval and affecting, sometimes adversely, overall motor-starting performance. Acceptable voltage for motor-starting depends on motor and

load torque characteristics. Requirements for minimum starting voltage can vary over a wide range, depending on the application. (Voltages can range from 80% or lower to 95% or higher.)

During motor-starting, the voltage level at the motor terminals should be maintained, as a minimum, at approximately 80% of rated voltage or above for a standard National Electrical Manufacturers Association (NEMA) design B motor (as specified in NEMA MG 1-1993)¹ having a standard 150% starting torque and with a constant torque load applied. This value results from examination of speed-torque characteristics of this type motor (150% starting torque at full voltage) and the desire to successfully accelerate a fully loaded motor at reduced voltage (that is, torque varies with the square of the voltage $T = 0.8^2 \times 150\% \approx 100\%$). When other motors are affected, or when lower shaft loadings are involved, the minimum permissible voltage may be either higher or lower, respectively. The speed-torque characteristics of the starting motor along with any other affected motors and all related loads should be examined to specifically determine minimum acceptable voltage. Assuming reduced voltage permits adequate accelerating torque, it should also be verified that the longer starting interval required at reduced torque caused by a voltage dip does not result in the I^2t damage limit of the motor being exceeded.

Several other problems may arise on the electrical power system due to the voltage dips caused by motor-starting. Motors that are running normally on the system, for example, will slow down in response to the voltage dip occurring when a large motor is started. The running machines must be able to reaccelerate once the machine being started reaches operating speed. When the voltage depression caused by the starting motor is severe, the loading on the running machines may exceed their breakdown torque (at the reduced voltage), and they may decelerate significantly or even stall before the starting interval is concluded. The decelerating machines all impose heavy current demands that only compound the original distress caused by the machine that was started. The result is a “dominoing” voltage depression that can lead to the loss of all load.

In general, if the motors on the system are standard NEMA design B, the speed-torque characteristics (200% breakdown torque at full voltage) should prevent a stall, provided the motor terminal voltage does not drop below about 71% of motor nameplate voltage. This is a valid guideline to follow anytime the shaft load does not exceed 100% rated, since the developed starting torque is again proportional to the terminal voltage squared (V^2), and the available torque at 71% voltage would thus be slightly above 100%. If motors other than NEMA design B motors are used on the system, a similar criterion can be established to evaluate reacceleration following a motor-starting voltage dip based on the exact speed-torque characteristics of each particular motor.

Other types of loads, such as electronic devices and sensitive control equipment, may be adversely effected during motor-starting. There is a wide range of variation in the amount of voltage drop that can be tolerated by static drives and computers. Voltage fluctuations may also cause objectionable fluctuations in lighting. Tolerable voltage limits should be obtained from the specific equipment manufacturers.

¹Information on references can be found in 9.8.

By industry standards (see NEMA ICS 1-1993, NEMA ICS 2-1993, NEMA ICS 3-1993, NEMA ICS 4-1993, NEMA ICS 6-1993), ac control devices are not required to pick-up at voltages below 85% of rated nameplate voltage, whereas dc control devices must operate dependably (i.e., pick-up) at voltages above 80% of their rating. Critical control operations may, therefore, encounter difficulty during motor-starting periods where voltage dips are excessive. A motor-starting study might be required to determine if this is a problem with thoughts to using devices rated at 110 V rather than the normal 115 V nominal devices. Contactors are required to hold-in with line voltage as low as 80% of their rating (see 9.8, NEMA Standards). The actual dropout voltages of contactors used in industrial applications commonly range between 60–70% of rated voltage, depending on the manufacturer. Voltages in this range, therefore, may be appropriate and are sometimes used as the criteria for the lower limit that contactors can tolerate. Depending on where lighting buses are located, with respect to large starting motors, this may be a factor requiring a motor-starting study. Table 9-1 summarizes some critical system voltage levels of interest when performing a motor-starting study for the purpose of evaluating the effects of voltage dips.

Table 9-1—Summary of representative critical system voltage levels when starting motors

Voltage drop location or problem	Minimum allowable voltage (% rated)
At terminals of starting motor	80% ^a
All terminals of other motors that must reaccelerate	71% ^a
AC contactor pick-up (by standard) (see 9.8, NEMA standards)	85%
DC contactor pick-up (by standard) (see 9.8, NEMA standards)	80%
Contactors hold-in (average of those in use)	60–70% ^b
Solid-state control devices	90% ^c
Noticeable light flicker	3% change
NOTE—More detailed information is provided in Table 51 of IEEE Std 242-1986.	

^aTypical for NEMA design B motors only. Value may be higher (or lower) depending on actual motor and load characteristics.

^bValue may be as high as 80% for certain conditions during prolonged starting intervals.

^cMay typically vary by $\pm 5\%$ depending on available tap settings of power supply transformer when provided.

9.2.3 Weak source generation

Smaller power systems are usually served by limited capacity sources, which generally magnify voltage drop problems on motor-starting, especially when large motors are involved. Small systems can also have on-site generation, which causes an additional voltage drop due to the relatively higher impedance of the local generators during the (transient) motor-starting interval. The type of voltage regulator system applied with the generators can dramatically

influence motor-starting as illustrated in Figure 9-1. A motor-starting study can be useful, even for analyzing the performance of small systems. Certain digital computer programs can accurately model generator transient behavior and exciter/regulator response under motor-starting conditions, providing meaningful results and conclusions.

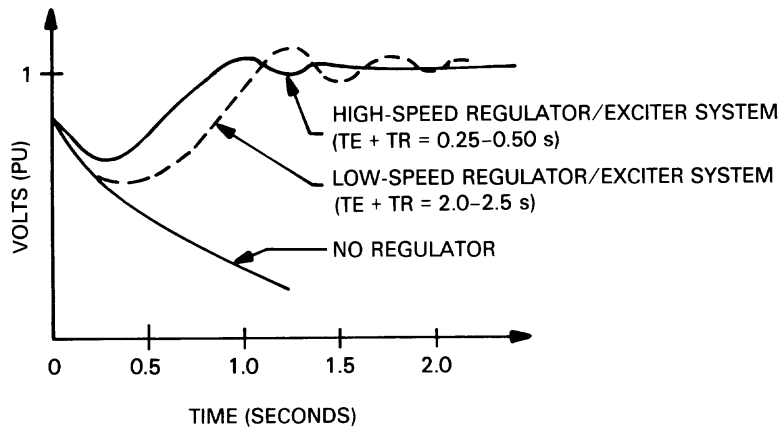

Figure 9-1—Typical generator terminal voltage characteristics for various exciter/regulator systems

9.2.4 Special torque requirements

Sometimes special loads must be accelerated under carefully controlled conditions without exceeding specified torque limitations of the equipment. An example of this is starting a motor connected to a load through gearing. This application requires a special period of low-torque cushioned acceleration to allow slack in the gears and couplings to be picked up without damage to the equipment. Certain computer-aided motor-starting studies allow an instant-by-instant shaft output torque tabulation for comparison to allowable torque limits of the equipment. This study can be used for selecting a motor or a starting method, or both, with optimum speed-torque characteristics for the application. The results of a detailed study are used for sizing the starting resistors for a wound rotor motor, or in analyzing rheostatic control for a starting wound rotor motor that might be used in a cushioned starting application involving mechanical gearing or a coupling system that has torque transmitting limitations. High-inertia loads increase motor-starting time, and heating in the motor due to high currents drawn during starting can be intolerable. A computer-aided motor-starting study allows accurate values of motor current and time during acceleration to be calculated. This makes it possible to determine if thermal limits of standard motors will be exceeded for longer than normal starting intervals.

Other loads have special starting torque requirements or accelerating time limits that require special high starting torque (and inrush) motors. Additionally, the starting torque of the load

or process may not permit low inrush motors in situations where these motors might reduce the voltage dip caused by starting a motor having standard inrush characteristics. A simple inspection of the motor and load speed-torque curves is not sufficient to determine whether such problems exist. This is another area where the motor torque and accelerating time study can be useful.

9.3 Recommendations

9.3.1 Voltage dips

A motor-starting study can expose and identify the extent of a voltage drop problem. The voltage at each bus in the system can, for example, be readily determined by a digital computer study. Equipment locations likely to experience difficulty during motor-starting can be immediately determined.

In situations where a variety of equipment voltage ratings are available, the correct rating for the application can be selected. Circuit changes, such as off-nominal tap settings for distribution transformers and larger than standard conductor-sized cable, can also be readily evaluated. On a complex power system, this type of detailed analysis is very difficult to accomplish with time-consuming hand solution methods.

Several methods of minimizing voltage dip on starting motors are based on the fact that during starting time, a motor draws an inrush current directly proportional to terminal voltage; therefore, a lower voltage causes the motor to require less current, thereby reducing the voltage dip.

Autotransformer starters are a very effective means of obtaining a reduced voltage during starting with standard taps ranging from 50% to 80% of normal rated voltage. A motor-starting study is used to select the proper voltage tap and the lower line current inrush for the electrical power system during motor start. Other special reduced-voltage starting methods include resistor or reactor starting, part-winding starting, and wye (Y)-start delta (Δ)-run motors. All are examined by an appropriate motor-starting study, and the best method for the particular application involved can be selected. In all reduced voltage starting methods, torque available for accelerating the load is a very critical consideration once bus voltage levels are judged otherwise acceptable. Only 25% torque is available, for example, with 50% of rated voltage applied at the motor terminals. Any problems associated with reduced starting torque imposed by special starting methods are automatically uncovered by a motor-starting study.

Another method of reducing high inrush currents when starting large motors is a capacitor starting system (see Harbaugh and Ponsting [B6]²). This maintains acceptable voltage levels throughout the system. With this method, the high inductive component of normal reactive starting current is offset by the addition, during the starting period only, of capacitors to the motor bus.

²The numbers in brackets preceded by the letter B correspond to those of the bibliography in 9.9.

This differs from the practice of applying capacitors for running motor power factor correction. A motor-starting study can provide information to allow optimum sizing of the starting capacitors and determination of the length of time the capacitor must be energized. The study can also establish whether the capacitor and motor can be switched together, or because of an excessive voltage drop that might result from the impact of capacitor transient charging current when added to the motor inrush current, the capacitor must be energized momentarily ahead of the motor. The switching procedure can appreciably affect the cost of final installation.

Use of special starters or capacitors to minimize voltage dips can be an expensive method of maintaining voltage at acceptable levels (see Harbaugh and Ponsting [B6]). Where possible, off-nominal tap settings for distribution transformers are an effective, economical solution for voltage dips. By raising no-load voltage in areas of the system experiencing difficulties during motor-starting, the effect of the voltage dip can often be minimized. In combination with a load flow study, a motor-starting study can provide information to assist in selecting proper taps and ensure that light load voltages are not excessively high.

The motor-starting study can be used to prove the effectiveness of several other solutions to the voltage dip problem as well. With a wound rotor motor, differing values of resistance are inserted into the motor circuit at various times during the starting interval to reduce maximum inrush (and accordingly starting torque) to some desired value. Figure 9-2 shows typical speed-torque characteristic curves for a wound rotor motor. With appropriate switching times (dependent on motor speed) of resistance values, practically any desired speed-torque (starting) characteristic can be obtained. A motor-starting study aids in choosing optimum current and torque values for a wound rotor motor application whether resistances are switched in steps by timing relays or continuously adjusted values obtained through a liquid rheostat feedback starting control.

For small loads, voltage stabilizers are sometimes used. These devices provide essentially instantaneous response to voltage fluctuations by “stabilizing” line voltage variations of as great as $\pm 15\%$ to within $\pm 1\%$ at the load. The cost and limited loading capability of these devices, however, have restricted their use mostly to controlling circuit power supply applications.

Special inrush motors can be purchased for a relatively small price increase over standard motors. These motors maintain nearly the same speed-torque characteristics as standard machines, but the inrush current is limited (usually to about 4.6 times full load current compared with 6 times full load current for a standard motor).

9.3.2 Analyzing starting requirements

A speed-torque and accelerating time study often in conjunction with the previously discussed voltage dip study permits a means of exploring a variety of possible motor speed-torque characteristics. This type of motor-starting study also confirms that starting times are within acceptable limits. The accelerating time study assists in establishing the necessary thermal damage characteristics of motors or verifies that machines with locked-rotor protection supervised by speed switches will not experience nuisance tripping on starting.

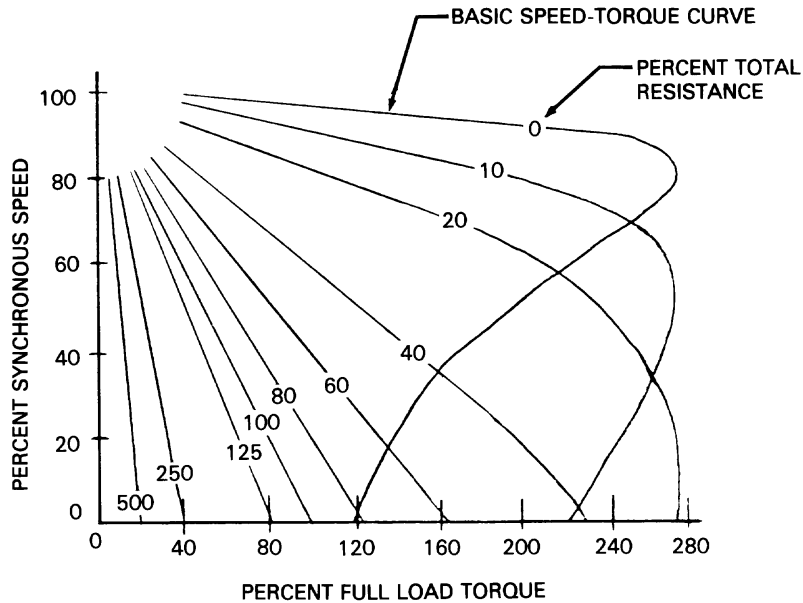

Figure 9-2—Typical wound rotor motor speed-torque characteristics

The speed-torque/accelerating time motor-starting study is also used to verify that special motor torque and/or inrush characteristics specified for motors to be applied on the system will produce the desired results. Mechanical equipment requirements and special ratings necessary for motor-starting auxiliary equipment are based on information developed from a motor-starting study.

9.4 Types of studies

From the previous discussion, it is apparent that, depending on the factors of concern in any specific motor-starting situation, more than one type of motor-starting study can be required.

9.4.1 The voltage drop snapshot

One method of examining the effect of voltage dip during motor-starting is to ensure the maximum instantaneous drop that occurs leaves bus voltages at acceptable levels throughout the system. This is done by examining the power system that corresponds to the worst-case voltage. Through appropriate system modeling, this study can be performed by various calculating methods using the digital computer. The so-called voltage drop snapshot study is useful only for finding system voltages. Except for the recognition of generator transient impedances when appropriate, machine inertias, load characteristics, and other transient

effects are usually ignored. This type of study, while certainly an approximation, is often sufficient for many applications.

9.4.2 The detailed voltage profile

This type of study allows a more exact examination of the voltage drop situation. Regulator response, exciter operation, and, sometimes, governor action are modeled to accurately represent transient behavior of local generators. This type of study is similar to a simplified transient stability analysis and can be considered a series of voltage snapshots throughout the motor-starting interval including the moment of minimum or worst-case voltage.

9.4.3 The speed-torque and acceleration time analysis

Perhaps the most exacting analysis for motor-starting conditions is the detailed speed-torque analysis. Similar to a transient stability study (some can also be used to accurately investigate motor-starting), speed-torque analysis provides electrical and accelerating torque calculations for specified time intervals during the motor-starting period. Motor slip, load and motor torques, terminal voltage magnitude and angle, and the complex value of motor current drawn are values to be examined at time zero and at the end of each time interval.

Under certain circumstances, even across-the-line starting, the motor may not be able to break away from standstill, or it may stall at some speed before acceleration is complete. A speed-torque analysis, especially when performed using a computer program, and possibly in combination with one or more previously discussed studies, can predict these problem areas and allow corrections to be made before difficulties arise. When special starting techniques are necessary, such as autotransformer reduced voltage starting, speed-torque analysis can account for the autotransformer magnetizing current and it can determine the optimum time to switch the transformer out of the circuit. The starting performance of wound rotor motors is examined through this type of study.

9.4.4 Adaptations

A particular application can require a slight modification of any of the above studies to be of greatest usefulness. Often, combinations of several types of studies described are required to adequately evaluate system motor-starting problems.

9.5 Data requirements

9.5.1 Basic information

Since other loads on the system during motor-starting affect the voltage available at the motor terminals, the information necessary for a load flow or short-circuit study is essentially the same as that required for a motor-starting study. This information is summarized below.

Details are available elsewhere in this recommended practice (see Chapters 6 and 7 as well as the *Electrical Transmission and Distribution Reference Book* [B4] and Beeman [B2]).

- a) *Utility and generator impedances.* These values are extremely significant and should be as accurate as possible. Generally, they are obtained from local utility representatives and generator manufacturers. When representing the utility impedance, it should be based on the minimum capacity of the utility system in order to yield the most pessimistic results insofar as voltage drop problems are concerned. This is in direct opposition to the approach normally used for a short-circuit analysis discussed in Chapter 7 of this standard. Where exact generator data cannot be obtained, typical impedance values are available from the *Electrical Transmission and Distribution Reference Book* [B4] and Beeman [B2].
- b) *Transformers.* Manufacturers' impedance information should be obtained where possible, especially for large units (that is, 5000 kVA and larger). Standard impedances can usually be used with little error for smaller units, and typical X/R ratios are available in IEEE Std C37.010-1979.
- c) *Other components.* System elements (such as cables) should be specified as to the number and size of conductor, conductor material, and whether magnetic duct or armor is used. All system elements should be supplied with R and X values so an equivalent system impedance can be calculated.
- d) *Load characteristics.* System loads should be detailed including type (constant current, constant impedance, or constant kVA), power factor, and load factor, if any. Exact inrush (starting) characteristics should also be given for the motor to be started.
- e) *Machine and load data.* Along with the aforementioned basic information, which is required for a voltage drop type of motor-starting analysis, several other items are also required for the detailed speed-torque and accelerating time analysis. These include the Wk^2 of the motor and load (with the Wk^2 of the mechanical coupling or any gearing included), and speed-torque characteristics of both the motor and load. Typical speed-torque curves are shown in Figure 9-3.

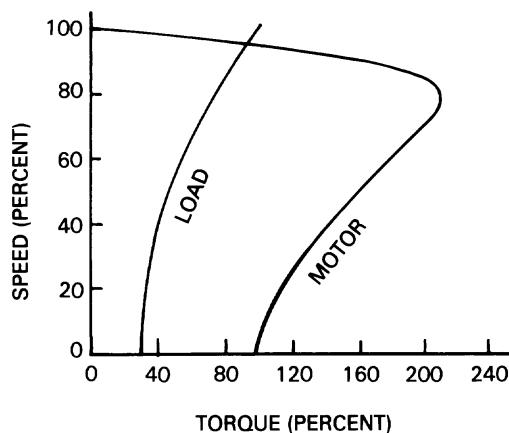

Figure 9-3—Typical motor and load speed-torque characteristics

For additional accuracy, speed versus current and speed versus power factor characteristics should be given for as exact a model as possible for the motor during starting. For some programs, constants for the motor equivalent circuit given in Figure 9-4 can be either required input information or typical default values. This data must be obtained from the manufacturer since values are critical. Exciter/regulator data should also be obtained from the manufacturer for studies involving locally connected generators.

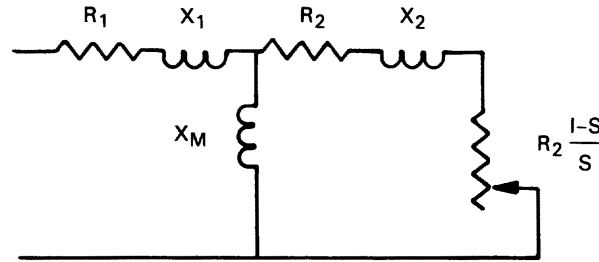

Figure 9-4—Simplified equivalent circuit for a motor on starting

When special motor applications are involved like high starting torque or low starting current, motor manufacturers may use special “deep bar” or double squirrel cage motor rotor designs. These designs can be represented either by their torque/speed curves, or by an equivalent electrical circuit model with two (or more) parallel rotor branches represented. This increases the complexity of the equivalent circuit and the corresponding mathematical solution beyond that of the more simplified single rotor model depicted in Figure 9-4.

9.5.2 Simplifying assumptions

Besides using standard impedance values for transformers and cables, it is often necessary to use typical or assumed values for other variables when making motor-starting voltage drop calculations. This is particularly true when calculations are for evaluating a preliminary design and exact motor and load characteristics are unknown. Some common assumptions used in the absence of more precise data follow:

- a) *Horsepower to kVA conversion.* A reasonable assumption is 1 hp equals 1 kVA. For synchronous motors with 0.8 leading, running power factor, and induction motors, it can easily be seen from the following equation:

$$\text{hp} = \frac{\text{kVA}(\text{PF})(\text{EFF})}{0.746} \quad (9-1)$$

The ratio of 0.746 to efficiency times the power factor approaches unity for most motors given the 1 hp/kVA approximation. Therefore, for synchronous motors operating at 1.0 PF, a reasonable assumption is 1 hp equals 0.8 kVA.

- b) *Inrush current.* Usually, a conservative multiplier for motor-starting inrush currents is obtained by assuming the motor to have a code G characteristic with locked-rotor current equal to approximately 6 times the full load current with full voltage applied at motor terminals [see the National Electrical Code[®] (NEC[®]) (NFPA 70-1996)]. A conservative and acceptably accurate method for determining the locked rotor current to full load running current ratio is to use the reciprocal of the motor's subtransient reactance when this characteristic is known.
- c) *Starting power factor.* The power factor of a motor during starting determines the amount of reactive current that is drawn from the system, and thus, to a large extent, the maximum voltage drop. Typical data (see Beeman [B2]) suggest the following:
- Motors under 1000 hp, PF = 0.20
 - Motors 1000 hp and over, PF = 0.15

The starting power factor can also be determined by knowing the short-circuit X/R ratio of the machine. Thus:

$$\text{Starting power factor} = \cos(\arctan X/R)$$

If a machine has an X''_d equal to 0.17 p.u. impedance on its own machine base, and a short-circuit X/R ratio of 5.0, then its locked rotor current ratio would be 5.9 and associated starting power factor would be 20%, or 0.2 p.u.

These power factor values are only rules of thumb for larger, integral horsepower-sized “standard” design motors. Actual motor power factors may vary dramatically from these values, especially for small horsepower size machines or any size special-purpose motor. For example, the starting power factor of a “standard” 5 horsepower motor may be 0.6 or larger, while the starting power factor of a high starting torque, fractional horsepower motor may be 0.85 or more. Wherever large numbers of small motors or any number of special torque characteristic motors are connected to a system or circuit, actual power factors should always be confirmed for purposes of performing accurate motor-starting calculations.

9.6 Solution procedures and examples

Regardless of the type of study required, a basic voltage drop calculation is always involved. When voltage drop is the only concern, the end product is this calculation when all system impedances are at maximum value and all voltage sources are at minimum expected level. In a more complex motor speed-torque analysis and accelerating time study, several voltage drop calculations are required. These are performed at regular time intervals following the initial impact of the motor-starting event and take into account variations in system impedances and voltage sources. Results of each iterative voltage drop calculation are used to calculate output torque, which is dependent on the voltage at machine terminals and motor speed. Since the interval of motor-starting usually ranges from a few seconds to 10 or more seconds, effects of generator voltage regulator and governor action are evident, sometimes along with transformer tap control depending on control settings. Certain types of motor-starting studies account for generator voltage regulator action, while a transient stability study is usually required in cases where other transient effects are considered important. A

summary of fundamental equations used in various types of motor-starting studies follows in this subclause, along with examples illustrating applications of fundamental equations to actual problems, including typical computer program outputs shown in Figures 9-10, 9-11, 9-13, and 9-14.

9.6.1 The mathematical relationships

There are basically three ways to solve for bus voltages realized throughout the system on motor-starting. These are presented in 9.6.1 and then examined in detail by examples in 9.6.2–9.6.5.

- a) *Impedance method.* This method involves reduction of the system to a simple voltage divider network (see Manning [B9]) where voltage at any point (bus) in a circuit is found by taking known voltage (source bus) times the ratio of impedance to the point in question over total circuit impedance. For the circuit of Figure 9-5,

$$V = E \frac{X_1}{X_1 + X_2} \quad (9-2)$$

or, more generally,

$$V = E \frac{Z_1}{Z_1 + Z_2} \quad (9-3)$$

The effect of adding a large capacitor bank at the motor bus is seen by the above expression for V . The addition of negative vars causes X_1 or Z_1 to become larger in both numerator and denominator, so bus voltage V is increased and approaches 1.0 per unit as the limiting improvement.

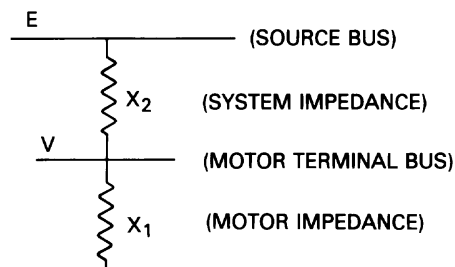

Figure 9-5—Simplified impedance diagram

Locked-rotor impedance for three-phase motor is simply

$$Z_{LR} = E \frac{\text{rated voltage } L-L}{(\sqrt{3}LRA)} \text{ in } \Omega \quad (9-4)$$

where

LRA is the locked-rotor current at rated voltage

This value in per unit is equal to the inverse of the inrush multiplier on the motor rated kVA base:

$$Z_{LR} = E \frac{1}{\left(\frac{LRA}{FLA}\right)} \text{ in per unit} \quad (9-5)$$

Since a starting motor is accurately represented as a constant impedance, the impedance method is a very convenient and acceptable means of calculating system bus voltages during motor-starting. Validity of the impedance method can be seen and is usually used for working hand calculations. Where other than simple radial systems are involved, the digital computer greatly aids in obtaining necessary network reduction. To obtain results with reasonable accuracy, however, various system impedance elements must be represented as complex quantities rather than as simple reactances.

- b) *Current method.* For any bus in the system represented in Figure 9-6 and Figure 9-7, the basic equations for the current method are as follows:

$$I_{\text{per unit}} = \frac{\text{MVA}_{\text{load}}}{\text{MVA}_{\text{base}}} \text{ at 1.0 per unit voltage} \quad (9-6)$$

$$V_{\text{drop}} = I_{\text{per unit}} \times Z_{\text{per unit}} \quad (9-7)$$

$$V_{\text{drop}} = V_{\text{source}} - V_{\text{drop}} \quad (9-8)$$

The quantities involved should be expressed in complex form for greatest accuracy, although reasonable results can be obtained by using magnitudes only for first-order approximations.

The disadvantage to this method is that, since all loads are not of constant current type, the current to each load varies as voltage changes. An iterative type solution procedure is therefore necessary to solve for the ultimate voltage at every bus, and such tedious computations are readily handled by a digital computer.

- c) *Load flow solution method.* From the way loads and other system elements are portrayed in Figure 9-6 and Figure 9-7, it appears that bus voltages and the voltage

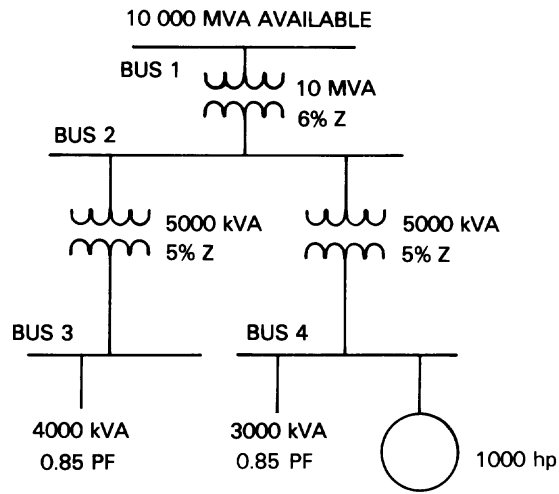

Figure 9-6—Typical single-line diagram

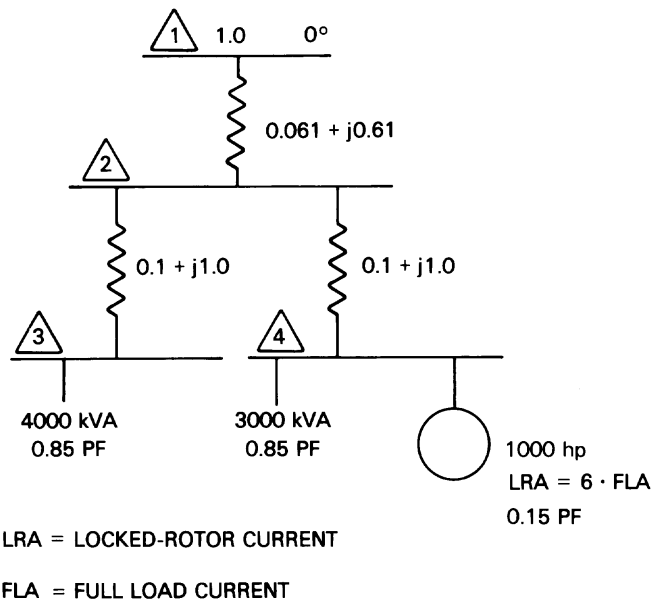

Figure 9-7—Impedance diagram for system in Figure 9-6

dip could be determined by a conventional load flow program. This is true. By modeling the starting motor as a constant impedance load, the load flow calculations yield the bus voltages during starting. The basic equations involved in this process are repeated here (see Neuenswander [B12] and Stagg and El-Abiad [B13]).

$$I_k = \frac{P_k - jQ_k}{V_k^*} - Y_k V_k \quad (9-9)$$

$$V_k = V_{\text{ref}} + \sum_{i=1}^n Z_{ki} \left(\frac{P_i - jQ_i}{V_i} - Y_i V_i \right) \quad (9-10)$$

where

- I_k is the current in the k th branch of any network
- P_k, Q_k is the real and reactive powers representative of the loads at the k th bus
- V_k is the voltage at the k th bus
- Y_k is the admittance to ground of bus k
- V_{ref} is the voltage of the swing or slack bus
- n is the number of buses in the network
- Z_{ki} is the system impedance between the k th and i th buses

The load flow solution to the motor-starting problem is very precise for finding bus voltages at the instant of maximum voltage drop. It is apparent from the expressions for I_k and V_k that this solution method is ideally suited for the digital computer any time the system involves more than two or three buses.

9.6.2 Other factors

Unless steady-state conditions exist, all of the above solution methods are valid for one particular instant and provide the single snapshot of system bus voltages as mentioned earlier. For steady-state conditions, it is assumed that generator voltage regulators have had time to increase field excitation sufficiently to maintain the desired generator terminal voltage. Accordingly, the presence of the internal impedance of any local generators connected to the system is ignored. During motor-starting, however, the influence of machine transient behavior becomes important. To model the effect of a close-connected generator on the maximum voltage drop during motor-starting requires inclusion of generator transient reactance in series with other source reactances. In general, use of the transient reactance as the representation for the machine results in calculated bus voltages and, accordingly, voltage drops that are reasonably accurate and conservative, even for exceptionally slow-speed regulator systems.

Assuming, for example, that bus 1 in the system shown in Figure 9-7 is at the line terminals of a 12 MVA generator rather than being an infinite source ahead of a constant impedance utility system, the transient impedance of the generator would be added to the system. The resulting impedance diagram is shown in Figure 9-8. A new bus 99 is created. Voltage at this new bus is frequently referred to as voltage behind the transient reactance. It is actually the internal machine transient driving voltage (see Chapter 3).

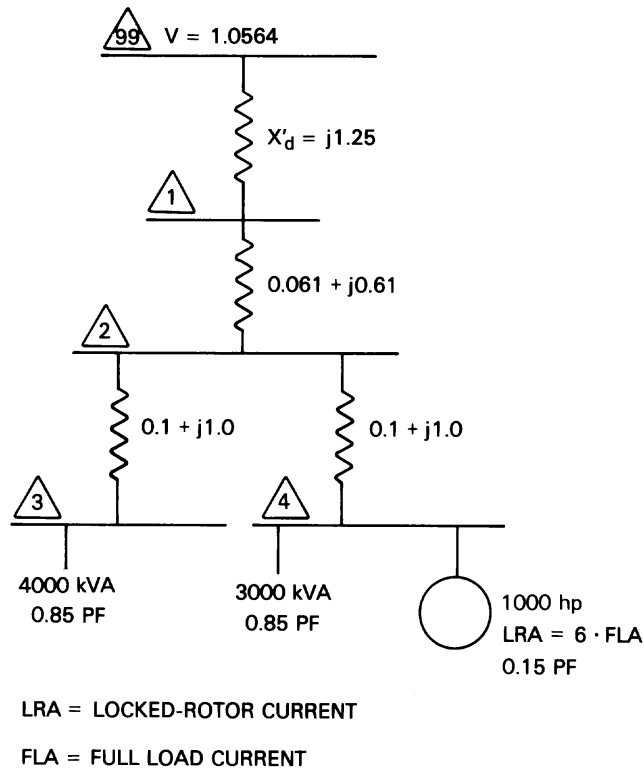

Figure 9-8—Revised impedance diagram showing transient reactance of generator

When the steady-state operating voltage is 1.0 per unit, the internal machine transient driving voltage can be considered the voltage that must be present ahead of the generator transient reactance with the terminal voltage maintained at 1.0 per unit (within exciter tolerances) during steady-state conditions while supplying power to the other loads on the system. The transient driving voltage V is calculated as follows:

$$\begin{aligned}
 V &= V_{\text{terminal}} + (jX'_d)I_{\text{load}} & (9-11) \\
 &= 1 + (jX'_d)(I_{\text{load}})
 \end{aligned}$$

where

$$V_{\text{terminal}} = 1.0 \text{ per unit} \quad (9-12)$$

$$I_{\text{load}} = \frac{\text{MVA}_{\text{load}}}{\text{MVA}_{\text{base}}} \text{ per unit}$$

Treatment of a locally connected generator is equally applicable to all three solution methods described previously. Such an approach cannot give any detail regarding the response of the generator voltage regulator or changes in machine characteristics with time. For a more detailed solution that considers time-dependent effects of machine impedance and voltage regulator action, the appropriate impedance and voltage terms in each expression must be continuously altered to accurately reflect changes that occur in the circuit. This procedure is also applicable to any solution methods considered. Figure 9-9 shows a simplified representation of the machine parameters that must be repeatedly modified to obtain the correct solution.

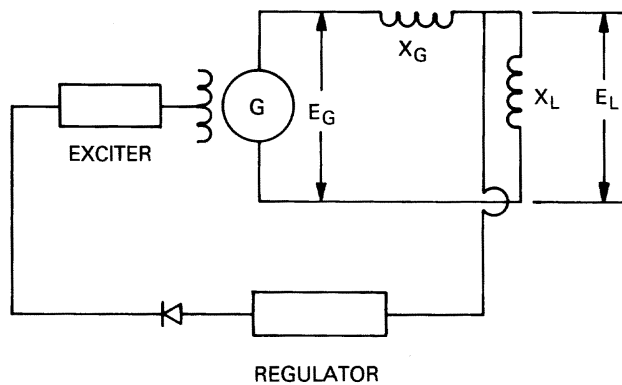

$$E_L = E_G \frac{X_L}{X_L + X_G}$$

where

X_G VARIES WITH TIME AS $X''_d \rightarrow X'_d \rightarrow X_d$,

E_G VARIES WITH TIME AS $T'_{do} \rightarrow T''_{do} \rightarrow T_{do}$

DEPENDENT ON EXCITER/REGULATOR OUTPUT

Figure 9-9—Simplified representation of generator exciter/regulator system

Some type of reduced voltage starting is often used to minimize motor inrush current and thus reduce total voltage drop, when the associated reduction in torque accompanying this starting method is permissible.

Representation used for the motor in any solution method for calculating voltage drop must be modified to reflect the lower inrush current. If autotransformer reduced voltage starting is used, motor inrush will be reduced by the appropriate factor from Table 9-2. If, for example, normal inrush is 6 times full load current and an 80% tap autotransformer starter is applied, the actual inrush multiplier used for determining the appropriate motor representation in the

calculations is (6) (0.64) = 4.2 × full load current. Resistor or reactor starting limits the line starting current by the same amount as motor terminal voltage is reduced (that is, 65% of applied bus voltage gives 65% of normal line starting current).

Table 9-2—Autotransformer line starting current

Autotransformer tap (% line voltage)	Line starting current (% normal at full voltage)
50	25
65	42
80	64

wye (Y)-start, delta (Δ)-run starting delivers 33% of normal starting line current with full voltage at the motor terminals. The starting current at any other voltage is, correspondingly, reduced by the same amount. Part winding starting allows 60% of normal starting line current at full voltage and reduces inrush accordingly at other voltages.

Adjustable speed drives generally provide suitable controls for limiting inrush currents associated with motor-starting. For this type of apparatus the inrush associated with motor-starting is almost always significantly less than for a motor-starting across the line. For purposes of motor-starting analysis, the starting current for the drive and motor simply can be modeled as the maximum imposed by the drive upon the system.

When a detailed motor speed-torque and accelerating time analysis is required, the following equations found in many texts apply (see Weidmer and Sells [B14]). The equations in general apply to both induction and synchronous motors, since the latter behave almost exactly as do induction machines during the starting period.

$$T \propto V^2$$

$$T = I_0 \alpha \tag{9-13}$$

$$I_0 = \frac{Wk^2}{2g} (\text{lb} \cdot \text{ft} \cdot \text{s}^2) \tag{9-14}$$

$$\omega^2 = \omega_0^2 + 2\alpha(\theta - \theta_0) (\text{r/s}) \tag{9-15}$$

$$\Delta\theta = \omega_0 t + 1/2 \alpha t^2 (\text{r}) \tag{9-16}$$

$$\alpha = \frac{T_n 2g}{Wk^2} (\text{r/s}^2) \tag{9-17}$$

A simplified approximation for starting time is also available:

$$t(s) = \frac{Wk^2(r/\text{min}_1 - r/\text{min}_2)(2\pi)}{60gT_n} \quad (9-18)$$

where

T	is the average motor shaft output torque
V	is the motor terminal voltage
I_0	is the moment of inertia
g	is the acceleration due to gravity
ω	is the angular velocity
α	is the angular acceleration
t	is the time in seconds to accelerate
T_n	is the net average accelerating torque between rev/min ₁ and rev/min ₂
θ	is the electrical angle in degrees
Wk^2	is the inertia

Substituting for g and rearranging yields:

$$t(s) = \frac{Wk^2(r/\text{min}_1 - r/\text{min}_2)}{308T_n}$$

The basic equation for use with the equivalent circuit of Figure 9-4 is as follows (see Fitzgerald, Kingsley, and Kusko [B5]; Beeman [B2]; and Peterson [B12]):

$$T = \frac{q_1 V^2 (r_2/s)}{\omega_s (r_1 + r_2/s)^2 + (X_1 + X_2)^2}$$

where

T	is the instantaneous torque
ω_s	is the angular velocity at synchronous speed
$(r_1 + jX_1)$	is the stator equivalent impedance
$(r_2/s + jX_2)$	is the rotor equivalent impedance
q_1	is the number of stator phases (3 for a 3 ϕ machine)
V	is the motor terminal voltage

9.6.3 The simple voltage drop determination

To illustrate this type of computer analysis, the system of Figure 9-6 will again be considered. It is assumed that bus 1 is connected to the terminals of a 12 MVA generator having 15% transient reactance (1.25 per unit on a 100 MVA base). Prior to starting, when steady-state load conditions exist, the impedance diagram of Figure 9-7 applies with the motor off-line. The impedance diagram of Figure 9-8 applies when the 1000 hp motor on bus 4 is started.

Bus 99 in Figure 9-8 has been assigned a voltage of 1.056 per unit. This value can be confirmed using the expression for the internal machine transient driving voltage V given in 9.6.2 with appropriate substitutions as follows:

$$\begin{aligned} V &= (1.0 + j0.0) + (j1.25)(0.060114 - j0.042985) \\ &= (1.0 + 1.0537) + (j0.07514) \\ &= 1.0564 \text{ p.u. voltage } \angle 4.08^\circ \end{aligned}$$

where values for the current through the X'_d element are expressed on a 100 MVA base and correspond to those that exist at steady state prior to motor-starting with bus 1 operating at 1.0 p.u. voltage. The computer output report of the steady-state load flow results for this case are shown both graphically and in tabular form in Figures 9-10 (a) and 9-10 (b), respectively. All system loads are on-line, except the 1000 hp motor. The two non-motor loads are modeled as constant power type loads. The 12 MVA generator must supply steady-state power equal to $6.011 + j4.299$ MVA, as noted in Figure 9-10 (a). The two loads combined require $5.955 + j3.687$ MVA. Therefore, the losses in the system, including those through the generator are equal to $0.056 + j0.612$ MVA. With these values of power flowing during steady-state, prior to motor-starting, the swing bus is at the required value of 1.0 p.u. voltage. The voltage drop at the motor bus, without the motor on line is 4.89%, resulting in an operating voltage prior to starting of 0.951 p.u. voltage.

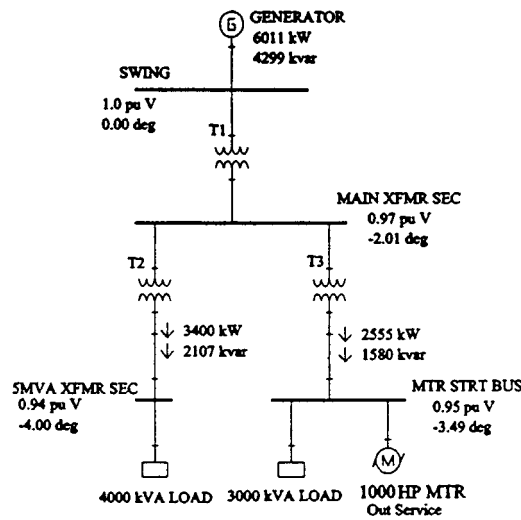

Figure 9-10 (a)—Computer-generated graphical output format—steady-state

For convenience, the voltage angle associated with the generator (or swing) bus is assumed to be zero, which results in the corresponding shift for all other bus voltages. Since the transformers are assumed to be connected delta-delta, the angular phase shifts indicated are

```

==== BUS: SWING          DESIGN VOLTS: 115000 BUS VOLTS: 115000 %VD: .00
===== PU BUS VOLTAGE: 1.000      ANGLE: .0 DEGREES
*** SWING GENERATOR: 6011 KW 4299 KVAR

LOAD TO: MAIN XFMR SEC  TRANSF AMPS: 36.0 VOLTAGE DROP: 3369. %VD: 2.93
PROJECTED POWER FLOW:   6011 KW 4299 KVAR 7390 KVA PF: .81 LAGGING

==== BUS: MAIN XFMR SEC  DESIGN VOLTS: 13800 BUS VOLTS: 13396 %VD: 2.93
===== PU BUS VOLTAGE: .971      ANGLE: -2.0 DEGREES

LOAD TO: 5MVA XFMR SEC  TRANSF AMPS: 177.2 VOLTAGE DROP: 366. %VD: 2.65
PROJECTED POWER FLOW:   3417 KW 2286 KVAR 4112 KVA PF: .81 LAGGING

LOAD TO: MTR STRT BUS   TRANSF AMPS: 131.9 VOLTAGE DROP: 271. %VD: 1.96
PROJECTED POWER FLOW:   2559 KW 1679 KVAR 3061 KVA PF: .81 LAGGING

==== BUS: 5MVA XFMR SEC  DESIGN VOLTS: 4160 BUS VOLTS: 3928 %VD: 5.58
===== PU BUS VOLTAGE: .944      ANGLE: -4.0 DEGREES
NET BRANCH LOAD: 3400 KW 2107 KVAR

LOAD FROM: MAIN XFMR SEC TRANSF AMPS: 587.9
PROJECTED POWER FLOW:   3400 KW 2107 KVAR 4000 KVA PF: .85 LAGGING

==== BUS: MTR STRT BUS   DESIGN VOLTS: 4160 BUS VOLTS: 3956 %VD: 4.89
===== PU BUS VOLTAGE: .951      ANGLE: -3.5 DEGREES
NET BRANCH LOAD: 2550 KW 1580 KVAR

LOAD FROM: MAIN XFMR SEC TRANSF AMPS: 437.7
PROJECTED POWER FLOW:   2550 KW 1580 KVAR 3000 KVA PF: .85 LAGGING

*** T O T A L   S Y S T E M   L O S S E S ***
                    56. KW      612. KVAR

```

Figure 9-10 (b)—Computer-generated output format in tabular form—steady-state

due to the voltage drops alone. It can be seen from the computer output report, shown both graphically and in tabular form in Figures 9-11 (a) and 9-11 (b), respectively, that when subsequent motor-starting calculations are made for this system, the voltage at the motor-starting bus is $0.794 \angle -9.56^\circ$ per unit.

Although this voltage is very close to the 0.80 p.u. value required to start many motors, it is well below the 0.85 p.u. criterion established earlier for proper operation of ac control devices that are connected at most motor-starting buses. Further examination of this problem with the calculation software would show that when the motor-starting interval is over, and the motor is operational, the voltage at the motor bus recovers to 0.92 p.u. A second study could be easily performed to explore the effects of increasing the motor-starting bus voltage, by adjusting the transformer tap settings.

9.6.4 Time-dependent bus voltages

The load flow solution method for examining effects of motor-starting allows a look at the voltage on the various system buses at a single point in time. A more exact approach is to model generator transient impedance characteristics and voltage sources closer to give results for a number of points in time following the motor-starting event. Although the solution

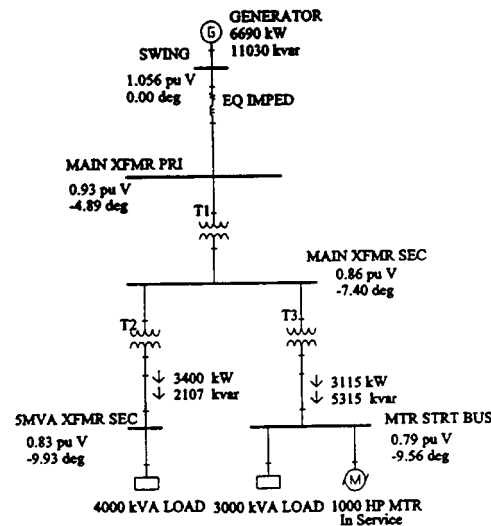

Figure 9-11 (a)—Computer-generated graphical output format—motor starting

methods are applicable to multiple generator/motor systems as well, equations can be developed for a system of the form shown in Figure 9-12 to solve for generator, motor, and exciter field voltages as a function of time. The digital computer is used to solve several simultaneous equations that describe the voltage of each bus in a system at time zero and at the end of successive time intervals.

Figures 9-13 through 9-16 show in detail the type of input information required and the output obtained from a digital computer voltage drop study. The system shown in Figure 9-12 contains certain assumptions, which include the following:

- a) Circuit losses are negligible—reactances only used in calculations.
- b) Initial load is constant kVA type.
- c) Motor-starting load is constant impedance type.
- d) Motor-starting power factor is in the range of 0 to 0.25.
- e) Mechanical effects, such as governor response, prime mover speed changes, and inertia constants, are negligible.

Plotted results obtained from the computer compare favorably to those expected from an examination of Figure 9-1. In the particular computer program used to obtain this report, the excitation system models available are similar to those described in IEEE Cmte. Paper [B6]. Excitation system models are shown in simplified form in Figure 9-17. Continuously acting regulators of modern design permit full field forcing for minor voltage variations (as little as 0.5%), and these voltage changes have been modeled linearly for simplicity.

```

==== BUS: SWING          DESIGN VOLTS: 115000 BUS VOLTS: 121440 %VD: -5.60
===== PU BUS VOLTAGE: 1.056      ANGLE: .0 DEGREES
*** SWING GENERATOR: 6690 KW 11030. KVAR

LOAD TO: MAIN XFMR PRI  FEEDER AMPS: 61.3 VOLTAGE DROP: 14627. %VD: 12.72
PROJECTED POWER FLOW: 6690 KW 11030 KVAR 12900 KVA PF: .52 LAGGING

==== BUS: MAIN XFMR PRI DESIGN VOLTS: 115000 BUS VOLTS: 106813 %VD: 7.12
===== PU BUS VOLTAGE: .929      ANGLE: -4.9 DEGREES

LOAD TO: MAIN XFMR SEC  TRANSF AMPS: 57.1 VOLTAGE DROP: 7332. %VD: 6.38
PROJECTED POWER FLOW: 6690 KW 9165 KVAR 11347 KVA PF: .59 LAGGING

==== BUS: MAIN XFMR SEC DESIGN VOLTS: 13800 BUS VOLTS: 11938 %VD: 13.49
===== PU BUS VOLTAGE: .865      ANGLE: -7.4 DEGREES

LOAD TO: 5MVA XFMR SEC  TRANSF AMPS: 200.4 VOLTAGE DROP: 416. %VD: 3.02
PROJECTED POWER FLOW: 3423 KW 2336 KVAR 4144 KVA PF: .59 LAGGING

LOAD TO: MTR STRT BUS   TRANSF AMPS: 324.8 VOLTAGE DROP: 987. %VD: 7.15
PROJECTED POWER FLOW: 3176 KW 5918 KVAR 6716 KVA PF: .59 LAGGING

==== BUS: 5MVA XFMR SEC DESIGN VOLTS: 4160 BUS VOLTS: 3473 %VD: 16.51
===== PU BUS VOLTAGE: .835      ANGLE: -9.9 DEGREES
NET BRANCH DIVERSITY LOAD: 3400 KW 2107 KVAR

LOAD FROM: MAIN XFMR SEC TRANSF AMPS: 664.9
PROJECTED POWER FLOW: 3400.0 KW 2107 KVAR 4000 KVA PF: .85 LAGGING

==== BUS: MTR STRT BUS DESIGN VOLTS: 4160 BUS VOLTS: 3301 %VD: 20.65
===== PU BUS VOLTAGE: .794      ANGLE: -9.6 DEGREES
NET BRANCH DIVERSITY LOAD: 3115 KW 5315 KVAR

LOAD FROM: MAIN XFMR SEC TRANSF AMPS: 1077.5
PROJECTED POWER FLOW: 3115 KW 5315 KVAR 6161 KVA PF: .51 LAGGING

*** TOTAL SYSTEM LOSSES ***
174. KW 3608. KVAR

```

Figure 9-11 (b)—Computer-generated output format in tabular form—
motor starting

Variations in exciter field voltage (EFV) over each time interval considered are used to calculate system bus voltages at the end of these same intervals. A single main machine field circuit time constant is used in the generator representation, and Fromlich's approximation (see Kimbark [B8]) for saturation effects is used when the voltage behind the generator leakage reactance indicates that saturation has been reached. The tabulated output stops just short of full recovery since a more complex model is necessary to represent overshoot, oscillation, etc., beyond this point. Of primary concern in this type of study is the maximum voltage dip and the length of time to voltage recovery as a function of generator behavior and voltage regulator performance.

9.6.5 The speed-torque and motor-accelerating time analysis

A simplified sample problem is presented for solution by hand. In this way, it is possible to appreciate how the digital computer aids in solving the more complex problems. The following information applies to the system shown in Figure 9-18.

- a) Motor hp = 1000 (induction)
- b) Motor r/min = 1800

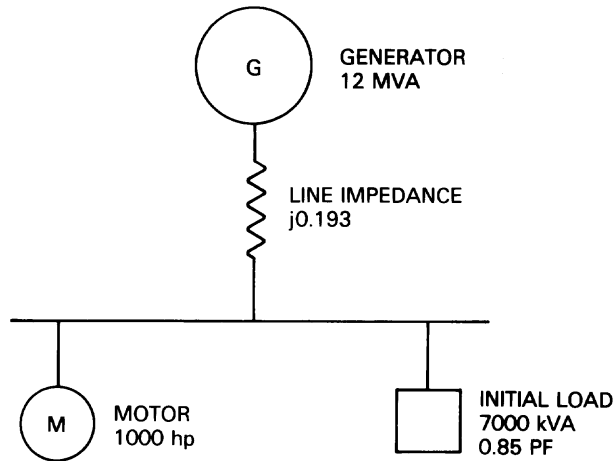

Figure 9-12—Simplified system model for generator representation during motor starting

- c) Motor $Wk2 = 270 \text{ lb}\cdot\text{ft}^2$
- d) Load $Wk2 = 810 \text{ lb}\cdot\text{ft}^2$

Assuming Figure 9-3 describes the speed-torque characteristic of the motor and the load, it is possible to find an average value for accelerating torque over the time interval defined by each speed change. This can be done graphically for hand calculations, and the results are tabulated in Table 9-3.

Applying the simplified formula for starting time provided earlier,

$$t_{0-25} = \frac{(270 + 810)(450 - 0)}{(308)(2260.4)} = 0.6981 \text{ s}$$

$$t_{25-50} = \frac{(1080)(900 - 450)}{(308)(2916.7)} = 0.5410 \text{ s}$$

$$t_{50-75} = \frac{(1080)(1350 - 900)}{(308)(3500.0)} = 0.4580 \text{ s}$$

$$t_{75-95} = \frac{(1080)(1710 - 1350)}{(308)(1822.9)} = 0.6925 \text{ s}$$

and, therefore, the total time to 95% of synchronous speed (or total starting time) is the sum of the times for each interval, or approximately 2.38 s. It can be seen how a similar

```

PROGRAM ASSUMPTIONS ---- 1. ONLY REACTANCES ARE USED IN CALCULATIONS.
                          2. EXCITER RESPONSE IS MODELED LINEARLY.
                          3. GENERATOR SATURATION IS MODELED WITH FROMLICH'S EQUATION.
                          4. THE INITIAL LOAD IS A CONSTANT KVA TYPE.
                          5. MOTOR STARTING LOAD IS A CONSTANT IMPEDANCE TYPE.
                          6. MOTOR STARTING PF IS IN THE RANGE 0.00 TO 0.25.
                          7. MECHANICAL EFFECTS (LIKE GOVERNOR RESPONSE, PRIME MOVER SPEED
                             CHANGES, ETC.) ARE NEGLECTED.

PROGRAM DATA BASE ----  GENERATOR kVA= 12000.00
                        XD=1.300
                        X'D=0.150
                        XL=0.120
                        T'DO= 5.000
                        IFAG= 0.395
                        IFNL= 0.450
                        IF130= 0.692
                        IFFL= 1.000
                        C=0.750

                        STATIC TYPE EXCITER
                        CEILING VOLTAGE=3.60 PU
                        SET POINT=1.00 PU
                        EXCITER TIME CONSTANT=0.32
                        REGULATOR TIME CONSTANT=0.0

                        REACTANCE BETWEEN GENERATOR AND BUS=0.193

                        HORSEPOWER OF STARTING MOTOR= 1000.0
                        INRUSH CURRENT IN PU OF RATED=6.00
                        RATED VOLTAGE= 1.
                        OPERATING VOLTAGE= 1.

                        INITIAL LOAD kVA= 7000.00
                        P.F.=0.85

NOTE ---- ANSWERS GIVEN BELOW REFLECT THE TIME REQUIRED FOR THE GENERATOR
          VOLTAGE TO RECOVER FROM THE IMPACT OF THE MOTOR STARTING LOAD.
          THEY DO NOT CORRESPOND TO THE TIME REQUIRED FOR THE MOTOR TO START,
          NOR DO THEY IMPLY THAT SUFFICIENT TORQUE IS AVAILABLE TO ACCELERATE THE MOTOR.
    
```

Figure 9-13—Typical output obtained from input—generator motor-starting program

TIME (SECONDS)	GENERATOR VOLTS (PU)	EXCITER FIELD VOLTS (PU)	MOTOR VOLTS (PU)
0-	1.00	1.61	0.94
0.0	0.93	1.61	0.79
0.1	0.92	2.12	0.78
0.2	0.92	2.62	0.78
0.3	0.92	3.13	0.78
0.4	0.94	3.60	0.80
0.5	0.97	3.60	0.83
0.6	0.99	3.60	0.85
0.7	1.00	3.60	0.86

Figure 9-14—Typical output—generator motor-starting program

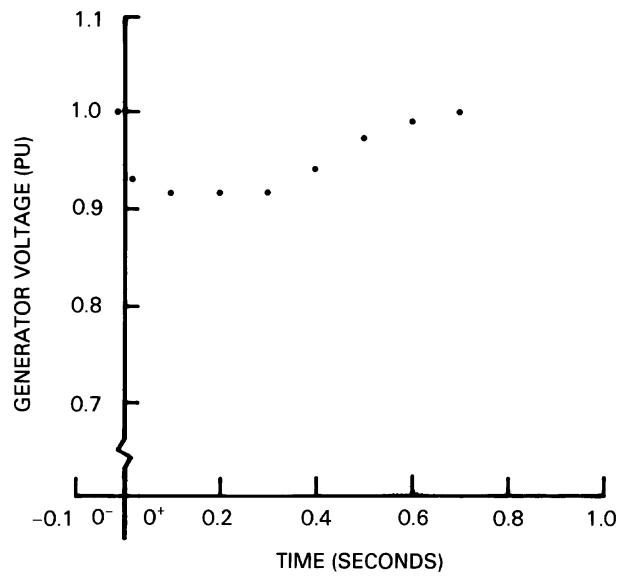

Figure 9-15—Typical output—plot of generator voltage dip

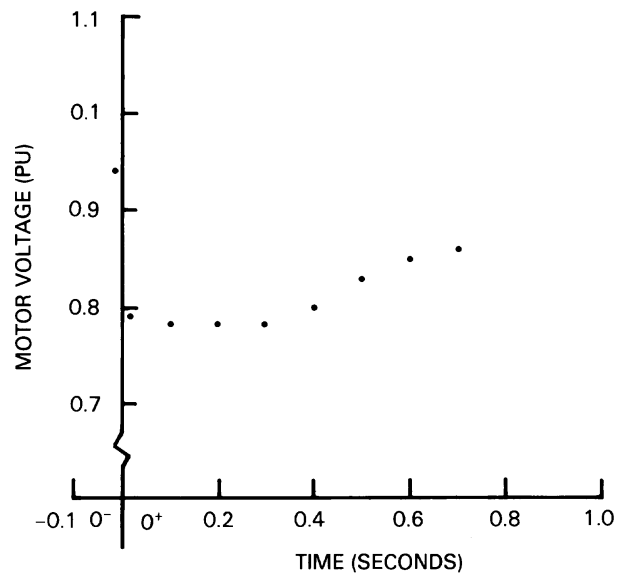
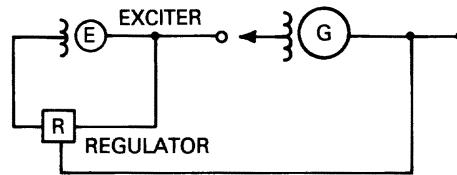
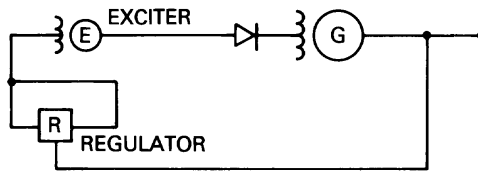

Figure 9-16—Typical output—plot of motor voltage dip



(a)



(b)

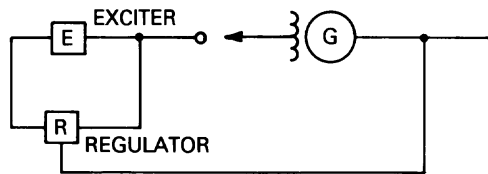

(c)

Figure 9-17—Simplified representation of typical regulator/exciter models for use in computer programs

technique can be applied to the speed-torque starting characteristic of a wound rotor motor (see Figure 9-2) to determine the required time interval for each step of rotor-starting resistance. The results of such an investigation can then be used to specify and set timers that operate resistor switching contactors or program the control of a liquid rheostat.

The current drawn during various starting intervals can be obtained from a speed-current curve, such as the typical one shown in Figure 9-19. This example has assumed full voltage available to the motor terminals, which is an inaccurate assumption in most cases. Actual voltage available can be calculated at each time interval. The accelerating torque will then change by the square of the calculated voltage. This process can be performed by graphically plotting a reduced voltage speed-torque curve proportional to the voltage calculated at each time interval, but this becomes tedious in a hand calculation. Sometimes, in the interest of simplicity, a torque corresponding to the motor terminal voltage at the instant of the maximum voltage dip is used throughout the starting interval. More accurate results are

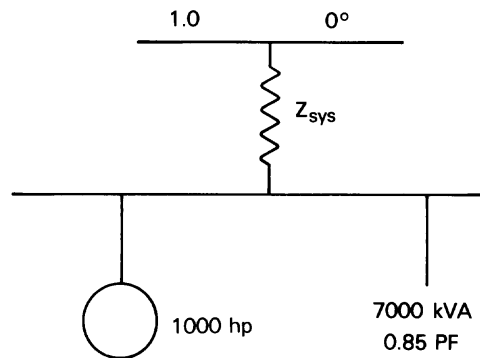

Figure 9-18—Simplified system model for accelerating time and speed-torque calculations

Table 9-3—Average values for accelerating torque over time interval defined by a speed change

Speed	T_{motor}	T_{load}	T_{net}	T_{net}
0%	100%	30%	—	—
—	—	—	77.5%	2260.4 lb-ft ²
25%	120%	35%	—	—
—	—	—	100%	2916.7 lb-ft ²
50%	160%	45%	—	—
—	—	—	120%	2500.0 lb-ft ²
75%	190%	65%	—	—
—	—	—	62.5%	1822.9 lb-ft ²
95%	80%	80%	—	—

possible with digital computer program analysis. A sample output report for the analysis is shown in Figure 9-20.

As a matter of interest, such a computer analysis using the torque speed and motor accelerating time method will be applied to the problem that was examined in Figure 9-6. Previously this problem was examined using the simple voltage drop method, and the results shown in Figure 9-11 (a) and 9-11 (b). Figure 9-21 shows a computer output plot of motor speed and motor-starting bus voltage as a function of time. The motor is started one second into the simulation. Figure 9-21 suggests that the 1000 hp motor in Figure 9-6 would start

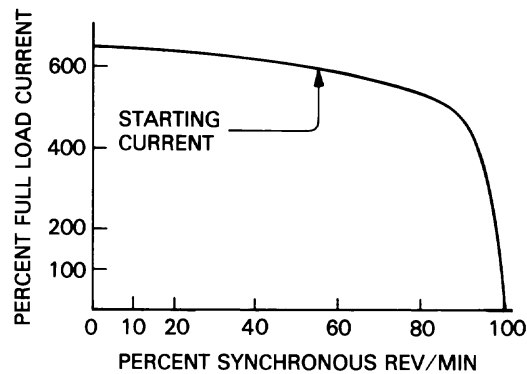

Figure 9-19—Typical motor speed-current characteristic

in about 15 s. The voltage at the motor-starting bus prior to starting the motor is 3.95 kV or 0.95 p.u.; however, the voltage at the motor-starting bus drops to 3.28 kV or 0.79 p.u. at the instant the motor starts, agreeing with the snapshot results presented in Figure 9-11. Also to be noted in Figure 9-21 is the steady-state operating voltage of 3.82 kV or 0.92 p.u. at the motor bus with all three loads in service, as was determined using the calculating procedures employed in 9.6.3. Figure 9-22 shows a similar computer-generated output plot for a second study case, where the main transformer taps are used to increase the transformer secondary bus voltage by 5%, and an autotransformer starter is applied to start the motor. With the +5% main transformer tap setting and the autotransformer starter modeled, the initial voltage drop on the motor-starting bus is improved, but not sufficiently to satisfy the 0.85 p.u. voltage criterion during starting, required for reliable ac controls operation, as mentioned in 9.6.3.

9.7 Summary

Several methods for analyzing motor-starting problems have been presented. Types of available motor-starting studies range from simple voltage drop calculation to the more sophisticated motor speed-torque and acceleration time study that approaches a transient stability analysis in complexity. Each study has an appropriate use, and the selection of the correct study is as important a step in the solution process as the actual performance of the study itself. Examples presented here should serve as a guide for determining when to use each type of motor-starting study, what to expect in the way of results, and how these results can be beneficially applied. The examples should also prove useful in gathering the required information for the specific type of study chosen. Experienced consulting engineers and equipment manufacturers can give valuable advice, information, and direction regarding the application of motor-starting studies as well.

```

MD 1 MOTOR TYPE- 1 TITLE-          BENCH MARK PROBLEM
MD 2 HP- 1000.  SPEED-1775 NEMA TYPE-A SYSTEM VOLTS- 4160.  RATED V- 4000.
MD 3 R1-      X1-      R2-      X2-      X0-
MD 4 NO. PHASES- 3 LOCKED ROTOR CURRENT-  FULL LOAD CURRENT- 145.
* WARNING --- LOCKED ROTOR CURRENT NOT INPUT OR IS INVALID. EXECUTION CONTINUING.
MD 5 INRUSH MULTIPLIER- 6.0 STARTING PF - .15 MOTOR INERTIA WKSQ- 500.
MD 6 MOTOR STARTER DATA--- TYPE- 2 RST-      XST-      TAP
ST 7 IND. POINTS-
* WARNING --- PROGRAM ASSUMING TYPICAL NEMA TYPE A TORQUE-SPEED CURVE.
SC 8 IND. POINTS-
* WARNING --- PROGRAM ASSUMING A TYPICAL SPEED-CURRENT CURVE.
PF 9 IND. POINTS-
* WARNING --- PROGRAM ASSUMING A TYPICAL SPEED-POWER FACTOR CURVE.
LD10 NO. POINTS-  LOAD TYPE-  NO LOAD
* WARNING --- LOAD'S TORQUE-SPEED CURVE MUST BE INPUT, OR IS ASSUMED AS NO LOAD CURVE. EXECUTION CONTINUING.
LD11 LOAD INERTIA WKSC-  GEARING RATIO
* WARNING --- MOTOR TO LOAD GEAR RATIO NOT INPUT OR IS INVALID. PROGRAM ASSUMES -- 1. EXECUTION CONTINUING.
SD12 SYSTEM IMPEDANCE RS- .00101 XS- .0101
SD13 SYSTEM GENERATION-  IMPEDANCE RG-      XG-
SD14 INITIAL SYSTEM LOAD TYPE- 3 RL-      XL- 7000.  PF- .85

```

**Figure 9-20—Typical output—motor speed-torque
and accelerating time program**

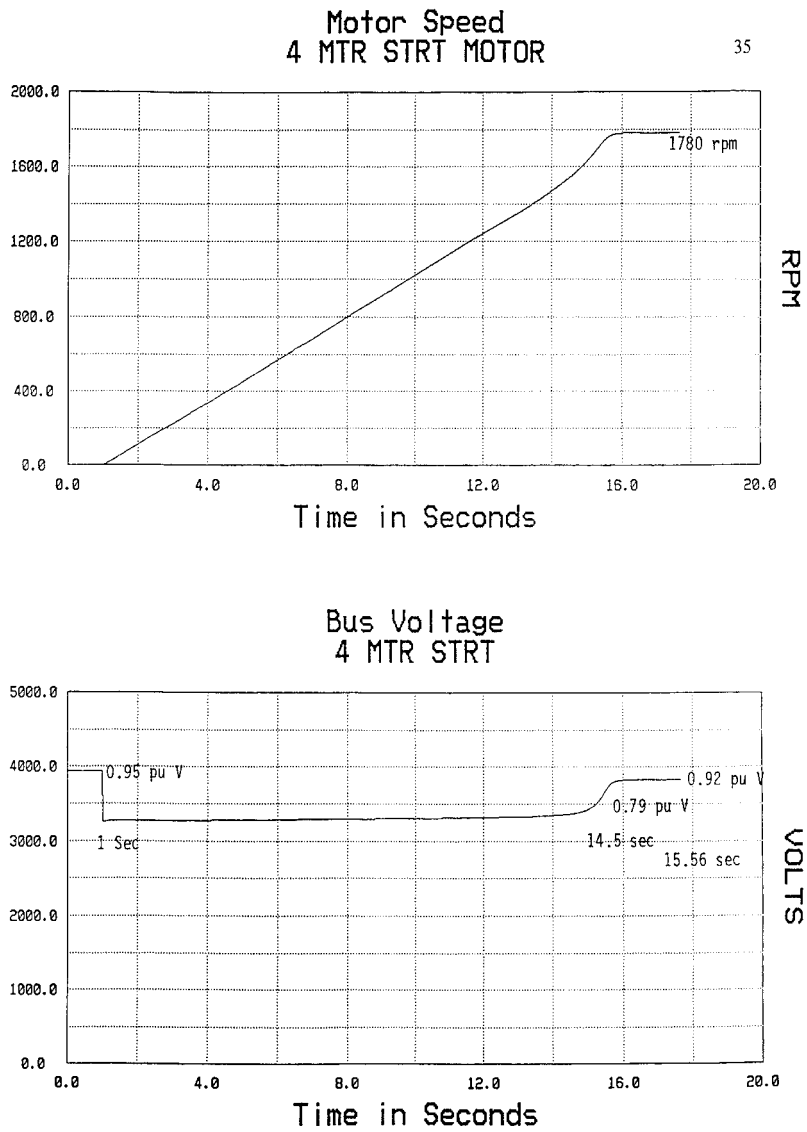

Figure 9-21—Computer-generated graphical output of motor speed and bus voltage vs. time—Motor started across the line and main transformer taps set on nominal voltage

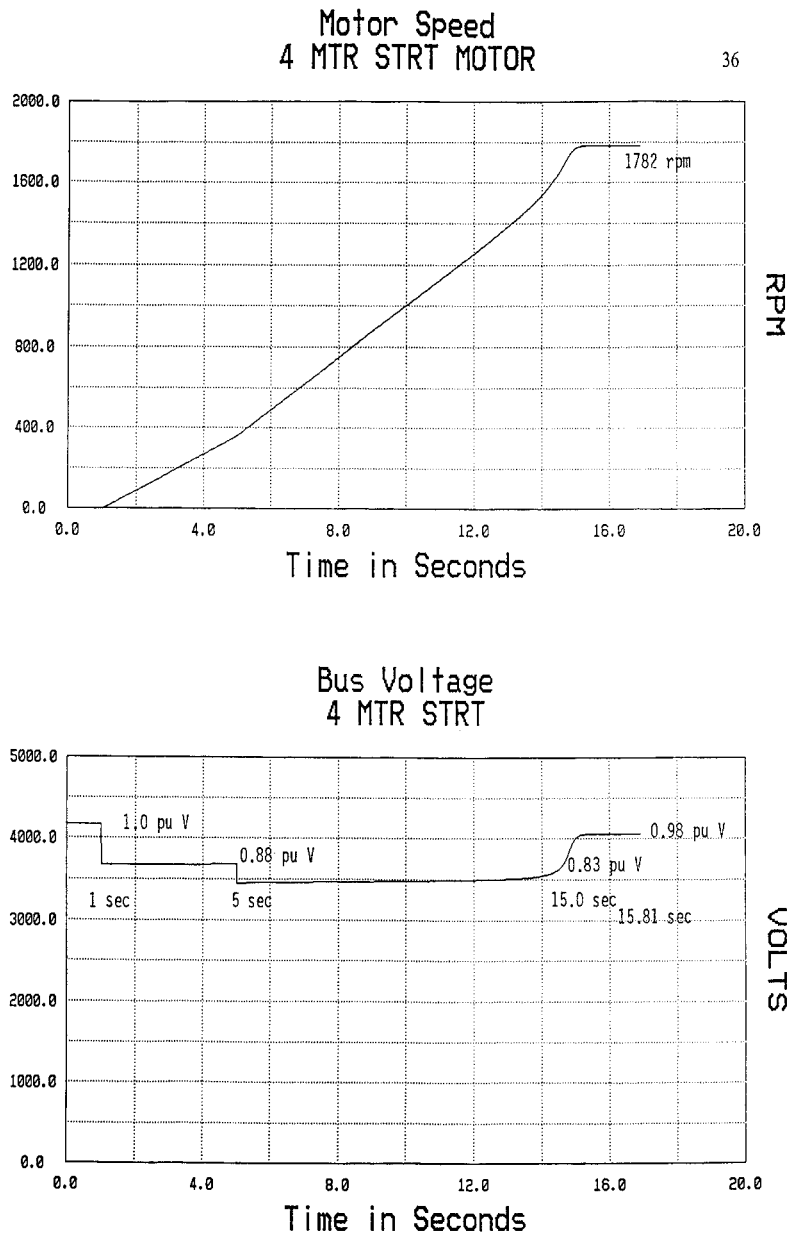

Figure 9-22—Computer-generated graphical output of motor speed and bus voltage vs. time—Main transformer with a tap setting to produce 5% above normal secondary voltage

9.8 References

IEEE Std 141-1993, IEEE Recommended Practice for Electric Power Distribution for Industrial Plants (IEEE Red Book).³

IEEE Std 242-1986 (Reaff 1991), IEEE Recommended Practice for Protection and Coordination of Industrial and Commercial Power Systems (IEEE Buff Book).

IEEE Std C37.010-1979 (Reaff 1988), IEEE Application Guide for AC High-Voltage Circuit Breakers Rated on a Symmetrical Current Basis.

NEMA ICS 1-1993, Requirements for Industrial Control and Systems.⁴

NEMA ICS 2-1993, Industrial Control Devices, Controllers and Assemblies.

NEMA ICS 3-1993, Industrial Systems.

NEMA ICS 4-1993, Terminal Blocks for Industrial Control and Systems.

NEMA ICS 6-1993, Enclosures for Industrial Control and Systems.

NEMA MG 1-1993, Motors and Generators.

NFPA 70-1996, National Electrical Code[®] (NEC[®]).⁵

9.9 Bibliography

[B1] Alger, P. L., *Induction Machines, Their Behavior and Uses*, Gordon and Breach Science Publishers, 1970.

[B2] Beeman, D., Ed., *Industrial Power Systems Handbook*, New York: McGraw-Hill, 1955.

[B3] Croft, T., Care, C., and Watt, J., *American Electrician's Handbook*, New York: McGraw-Hill, 1970.

[B4] *Electrical Transmission and Distribution Reference Book*, Westinghouse Electric Corporation, East Pittsburgh, Pennsylvania, 1964.

³IEEE publications are available from the Institute of Electrical and Electronics Engineers, 445 Hoes Lane, P.O. Box 1331, Piscataway, NJ 08855-1331, USA.

⁴NEMA publications are available from the National Electrical Manufacturers Association, 1300 N. 17th St., Ste. 1847, Rosslyn, VA 22209, USA.

⁵The NEC is available from Publications Sales, National Fire Protection Association, 1 Batterymarch Park, P.O. Box 9101, Quincy, MA 02269-9101, USA. It is also available from the Institute of Electrical and Electronics Engineers, 445 Hoes Lane, P.O. Box 1331, Piscataway, NJ 08855-1331, USA.

- [B5] Fitzgerald, A., Kingsley, C., and Kusko, A., *Electric Machinery*, New York: McGraw-Hill, 1971.
- [B6] Harbaugh, J., and Ponsting, L., "How to Design a Capacitor Starting System for Large Induction and Synchronous Motors," IEEE IAS 1975 Annual Meeting, Conference Record.
- [B7] IEEE Power Generation Committee, "Computer Representation of Excitation Systems," Paper 31 TP 67-424, May 1, 1967.
- [B8] Kimbark, E., *Power System Stability: Synchronous Machines*, New York: Dover Publications, 1956.
- [B9] Manning, L., *Electrical Circuits*, New York: McGraw-Hill, 1966.
- [B10] Neuenswander, J., *Modern Power Systems*, International Text Book Company, 1971.
- [B11] Peterson, H., *Transients in Power Systems*, New York: Dover Publications, 1951.
- [B12] Prabhakara, F. S., Smith, Jr., R. L., and Stratford, R. P., *Industrial and Commercial Power Systems Handbook*, McGraw-Hill, 1995.
- [B13] Stagg, and El-Abiad, *Computer Methods in Power System Analysis*, New York: McGraw-Hill, 1971.
- [B14] Weidmer, R., and Sells, R., *Elementary Classical Physics*, 2 vols., Boston, Allyn and Bacon, Inc., 1965.

Chapter 10

Harmonic analysis studies

10.1 Introduction

This chapter discusses the basic concepts involved in studies of harmonic analysis of industrial and commercial power systems. The need for such an analysis, recognition of potential problems, corrective measures, required data for analysis, and benefits of using a computer as a tool in a harmonic analysis study are also addressed in this chapter.

Traditionally, the main source of harmonics in power systems has been the static power converter used as rectifiers for various industrial processes; however, the static power converter is now used in a variety of additional applications such as adjustable speed drives, switched-mode supplies, frequency changers for induction heating, etc. Semiconductor devices are being increasingly used as static switches that modulate the voltage applied to loads. Examples of these are soft starters for motors, static var compensators, light dimmers, electronic ballasts for arc-discharge lamps, etc. Other examples are devices with nonlinear voltage-current characteristics such as arc furnaces or saturable electromagnetic devices.

Since nonlinear loads represent an ever-increasing percentage of the total load of an industrial or commercial power system, harmonic studies have become an important part of overall system design and operation. Fortunately, the available software for harmonic analysis has also grown. Guidelines for the acceptance of harmonic distortion are well-defined in IEEE Std 519-1992.¹

By modeling power system impedances as a function of frequency, a study can be made to determine the effect of the harmonic contributions from nonlinear loads on the voltages and currents in the power system. Most commercial software for harmonic analysis offer the following:

- a) Calculation of harmonic bus voltages and branch current flows in the network due to harmonic sources,
- b) Resonances in the existing or planned system,
- c) Performance indices that calculate the effects of harmonics on voltage or current waveform distortion, telephone interference, etc.

The software can also help in selecting and locating capacitors or passive filters to optimize system performance.

Details of system modeling and applicable standards are discussed. The treatment described here particularly applies to industrial and commercial systems at low and medium voltages, but the basics are also applicable to other systems and higher voltages. this chapter does not

¹Information on references can be found in 10.9.

deal with active filters as part of the filter design; however, some reference is made to their application.

It may be said at the outset that the harmonic filter design is very closely linked to power-factor (PF) requirements of the system (based on utility tariffs) and both must be considered at the same time. In the past, many PF compensation studies have been made without regard to the possible resonances in the system or harmonic absorption by the capacitors.

IEEE Std 519-1992 should be referred to for general information and particularly for harmonic generation from static power converters and other harmonic sources. A considerable reference list (10.9) and bibliography (10.10) are provided for this chapter, which should be referred to for details in specific areas.

10.2 Background

As a matter of definition, any load or device that does not draw a sinusoidal current when excited by a sinusoidal voltage of the same frequency is termed a nonlinear load. The most common are switching devices, such as solid-state converters, which force the conduction of currents for only certain periods and, to a lesser extent, saturable impedance devices such as transformers with nonlinear voltage vs. impedance characteristics. A nonlinear load is considered a source of harmonic currents, where harmonic frequencies are generally considered to be integer multiples of the system frequency. However, certain nonlinear loads, such as an arc furnace or a cycloconverter, may also have non-integer harmonic frequencies in addition to the expected integer harmonics.

Harmonics, by definition, occur in every cycle of the fundamental current and are calculated as part of the steady-state solution. However, exceptions exist, and harmonics may vary from cycle to cycle. These are termed time-varying harmonics. Also, harmonics appear in quasi-steady-state or transient situations, such as in magnetization inrush current of a transformer. This chapter does not deal with transient harmonics or time-varying harmonics.

An ideal current source is one which provides a constant current irrespective of the system impedance seen by the source. In most studies for industrial applications, the nonlinear load or the harmonic source is considered an ideal current source without a Norton's impedance across the source (i.e., Norton impedance is assumed to be infinite). This approximation is generally reasonable and yields satisfactory results. When the nonlinear device acts like a voltage source [e.g., a pulse-width-modulated (PWM) inverter], a Norton equivalent current source model may still be used since most computer programs are based on the current injection method (see 10.5.7).

Since the system is subjected to current injections at multiple frequencies, the network is solved for voltage and current at each frequency separately. The total voltage or current in an element is then found either by a root-mean-square sum or arithmetic sum, using the principle of superposition.

The generated harmonic frequencies are dependent upon the type of nonlinear load. Most nonlinear loads produce odd harmonics with small even harmonics. However, loads such as arc furnaces produce the entire spectrum of harmonics: odd, even, and non-integer harmonics in between (non-integer harmonics are also referred as “interharmonics”). Generally, the amplitude of the harmonics decreases as the frequency (or the harmonic order) increases.

The effect of harmonic current propagation through the network, including the power source, produces distortion of the voltage waveform depending upon harmonic voltage drops in various series elements of the network. Therefore, the voltage distortion at a given bus is dependent on the equivalent source impedance; the smaller the impedance, the better the voltage quality. Note that the harmonic sources, which are nonlinear loads, are not the sources of power, but are the cause of additional active and reactive power losses in the system.

10.3 Purpose of harmonic study

With the growing proliferation of nonlinear loads in commercial buildings and industrial plants, which may be in the range of 30% to 50% of the total load, the effects of harmonics within the system and their impact on the utility and neighboring loads needs to be examined before any complaints are made, equipment is damaged, or production is lost.

The following situations may necessitate a harmonic study, which should include recommendations for mitigating the effects of harmonics (see 10.7):

- a) Compliance with IEEE Std 519-1992, which defines the current distortion limits a user should meet at the point of common coupling (PCC) with the utility. Voltage distortion limits are also defined as a basis for the system design. The voltage distortion limits are primarily intended for the utility to provide a good sine wave voltage; however, an individual user is expected to use the voltage limits as a basis for the system design. The chances are that if the current distortion limits are met, the voltage distortion limits will also be met, except in some unusual circumstances.
- b) A history of harmonic-related problems, such as failure of power-factor compensation capacitors, overheating of cables, transformers, motors, etc., or misoperation of protective relays or control devices.
- c) Plant expansion where significant nonlinear loads are added or where a significant amount of capacitance is added.
- d) Design of a new facility or power system, where the load-flow, power factor compensation, and harmonic analyses are considered as one integrated study to determine how to meet the reactive power demands and harmonic performance limits.

When harmonics appear to be the cause of system problems, it is necessary to determine the resonant frequencies at the problem sites. With power-factor correction capacitor banks, a parallel system resonance can occur at or near one of the lower harmonic orders (3, 5, ...). This resonance can be critical if excited by a harmonic current injection at that frequency. Refer to 10.4.3 for an approximate calculation of harmonic resonant frequency. An estimate of the resonant frequencies is very useful for an initial evaluation.

It is not uncommon to encounter a system in which it is more practical to take harmonic measurements as a diagnostic tool rather than to perform a detailed, time-consuming, harmonic analysis study. In other cases, measurements are used to verify the system model prior to the performance of a detailed harmonic analysis study. This is especially desirable for arc furnace installations. In order to ensure that harmonic measurements will produce reliable results, careful consideration must be given to both test equipment and procedures being applied, see Schieman and Schmidt [B35] and Shipp [B38]². The test results may identify the cause of a harmonic problem so that the need for a detailed harmonic study is either eliminated or the study is simplified.

10.4 General theory

10.4.1 Harmonic sources

All harmonic sources are referred to as nonlinear loads because they draw non-sinusoidal currents when a sinusoidal voltage is applied. The non-sinusoidal current may be due to the inherent characteristic of the load (e.g., arc furnaces), or due to a switching circuit (e.g., a 6-pulse converter that forces conduction of currents for only certain periods). In industrial and commercial power systems there may be many such harmonic sources distributed throughout the system.

The harmonic study requires knowledge of the harmonic currents generated by nonlinear loads. There are three options open to the analytical engineer:

- a) Measure the generated harmonics at each source,
- b) Calculate the generated harmonics by a mathematical analysis where possible, such as at converters or static var compensators, and
- c) Use typical values based on similar applications or published data.

In practice, all three methods are used and provide reasonable results.

Since the system configuration and load continually change, the harmonics also change and it would be a formidable task to study all such conditions. Usually, the worst operating condition is determined, and the design is based on the “worst-generated” harmonics. However, It needs to be recognized that even with the “worst generated” harmonic case, the harmonic flows within different elements of the network can be different depending upon the number of transformers or tie breakers in service. This necessitates that for the “worst generated” case, the “worst operating cases(s)” must be analyzed.

One other difficulty in the analysis arises from the fact that when multiple harmonic sources are connected to the same bus (or different buses), the phase angles between the harmonics of the same order are usually not known. This, generally speaking, leads to arithmetic addition of harmonic magnitudes, which may be reasonable if the harmonic sources are similar and

²Numbers in brackets correspond to those of the bibliography in 10.10.

have similar operating load points. However, this approach can lead to a more conservative filter design and distortion calculations, if the sources are different or operate at different load points. Determination of phase angles of harmonics and vectorial addition can be quite a complex and expensive approach for general industrial application. This is often resolved by simplifying assumptions based on experience or by field measurements. More advanced techniques are used in high-voltage dc transmission and other utility applications where accuracy is important.

Industrial harmonic studies are usually represented on a single-phase basis, i.e., based on the assumption that the system is balanced and positive sequence analysis applies. A three-phase study is warranted only if the system or the load is severely unbalanced or a four-wire system with single-phase loads exist. In such a situation it will be very desirable to determine the harmonics generated in all three phases. If the harmonic generation is assumed to be balanced and the system is considered unbalanced, a three-phase study may not serve the full purpose. The cost of a three-phase study could be higher than a single-phase study and should be used only when such an expense and purpose can be justified.

10.4.2 Effects of harmonics

The effects of harmonics are described here only in the context of the analytical harmonic system study, details of these effects can be found in referenced literature. IEEE Std 519-1992 (Chapter 6) and Prabhakara, Smith, and Stratford [B30] (Chapter 5) deal with the subject in detail. The effects of harmonics in a power system are pervasive in that they influence system losses, system operation, and system performance. Unless the harmonics are controlled to acceptable limits, the power equipment and, even more so, the electronic equipment may be damaged resulting in and costly system outages.

The effects of harmonics are due to both current and voltage, although current-produced effects are more likely to be seen in day-to-day performance. Voltage effects are more likely to degrade the insulation and hence shorten the life of the equipment. The following describes some of the common effects of harmonics:

- a) Increased losses within the equipment and associated cables, lines, etc.,
- b) Pulsating and reduced torque in rotating equipment,
- c) Premature aging due to increased stress in the equipment insulation,
- d) Increased audible noise from rotating and static equipment,
- e) Misoperation of equipment sensitive to waveforms,
- f) Substantial amplification of currents and voltages due to resonances, and
- g) Communication interference due to inductive coupling between power and communication circuits.

Generally, harmonic studies involving harmonic flows and filter design do not involve detailed analysis of the effects of harmonics if the limits imposed by the user or by a standard are met. However, in specific cases, analysis of harmonics penetrating into rotating equipment, causing relay misoperation, or interfering with communication circuits may require a separate study.

For additional information see the IEEE Task Force Report [B21].

10.4.3 Resonance

Most power system circuit elements are primarily inductive and, therefore, the presence of shunt capacitors used for power-factor correction or harmonic filtering can cause cyclic energy transfer between the inductive and capacitive elements at the natural frequency of resonance. At this frequency the inductive and capacitive reactances are equal.

The combination of inductive (L) and capacitive (C) elements as viewed from a bus of interest, generally the bus at which harmonic currents are injected by a nonlinear load (source bus), can result in either a series resonance (L and C in series) or a parallel resonance (L and C in parallel). As shown in the following sections, the series resonance results in low impedance and parallel resonance in high impedance. At either series or parallel resonance, the net impedance is resistive. In harmonic studies, it is essential that the driving-point impedance (see 10.5.7), as seen from the harmonic source bus (or other bus of interest), be examined to identify the series and parallel resonance frequencies and resulting impedances.

In practical electrical systems, PF correction capacitors are utilized to offset the power factor penalty imposed by the utility. This can create an abnormal situation, because the combination of capacitors and inductive elements in the system can result in either series or parallel resonance or a combination of both depending upon the system configuration. Usually parallel resonance occurs more often because capacitor banks act in parallel with system impedance (inductive); this can be a matter of concern if the resonant frequency happens to be close to one of the frequencies generated by the harmonic sources in the system.

The result of a series resonance may be the flow of unexpected amounts of harmonic currents through certain elements. A common manifestation of excessive harmonic current flow is inadvertent relay operation, burned fuses, and overheating of cables, etc.

The result of a parallel resonance may be the presence of excessive harmonic voltages across network elements. A common manifestation of excessive harmonic voltages is capacitor or insulation failure.

10.4.3.1 Series resonance

An example of series resonant circuit is shown in Figure 10-1. Each circuit element is described in terms of its impedance. The equivalent impedance of the circuit and the current flow are expressed by Equations (10-1) and (10-2). This circuit is said to be in resonance when the inductive reactance X_L is equal to the capacitive reactance X_C . The resonant frequency at which $X_L = X_C$ is given by Equation (10-3a).

$$\bar{Z} = R + j(X_L - X_C) \quad (10-1)$$

$$\bar{I} = \frac{\bar{V}}{R + j(X_L - X_C)} \quad (10-2)$$

$$= \frac{V}{R} \text{ at resonance } (X_L = X_C) \quad (10-2a)$$

$$\omega_0 = \frac{1}{\sqrt{LC}} \quad (10-3)$$

$$f_0 = \frac{1}{2\pi\sqrt{LC}} \quad (10-3a)$$

Given the relatively low values of series resistance usually found in power equipment, the magnitude of the current in Equation (10-2a) can be large at resonance.

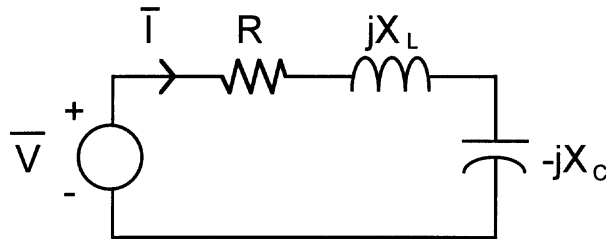

Figure 10-1—Example circuit for series resonance

Figure 10-2 shows the equivalent impedance of the circuit in Figure 10-1 as a function of frequency. The element values are $R = 2 \Omega$, $L = 3.98 \text{ mH}$, and $C = 36.09 \mu\text{F}$. It is clear from Equation (10-1) that the impedance appears capacitive at low frequencies and becomes inductive as the frequency increases, and that resonance occurs at 420 Hz (7th harmonic for a 60 Hz system).

A general measure of the shape of the impedance plot of Figure 10-2 is often given in terms of the quality factor Q . For a series resonant circuit, the Q is defined in Equation (10-4) at any angular frequency ω .

$$Q = \frac{\omega L}{R} \quad (10-4)$$

At the resonant frequency, the Q is generally approximated to the ratio of $\omega_0 L/R_L$ since $R \approx R_L$ as capacitors have negligible resistance. As will be demonstrated in 10.6, the parameter Q often plays an important role in filter design because most single-tuned harmonic filters are simple RLC series-resonant circuits. In general, a higher Q produces a more pronounced “dip” in the plot of Figure 10-2. A lower Q results in a more rounded shape. In most filter applications, the natural quality factor (with no intentional resistance) is relatively high

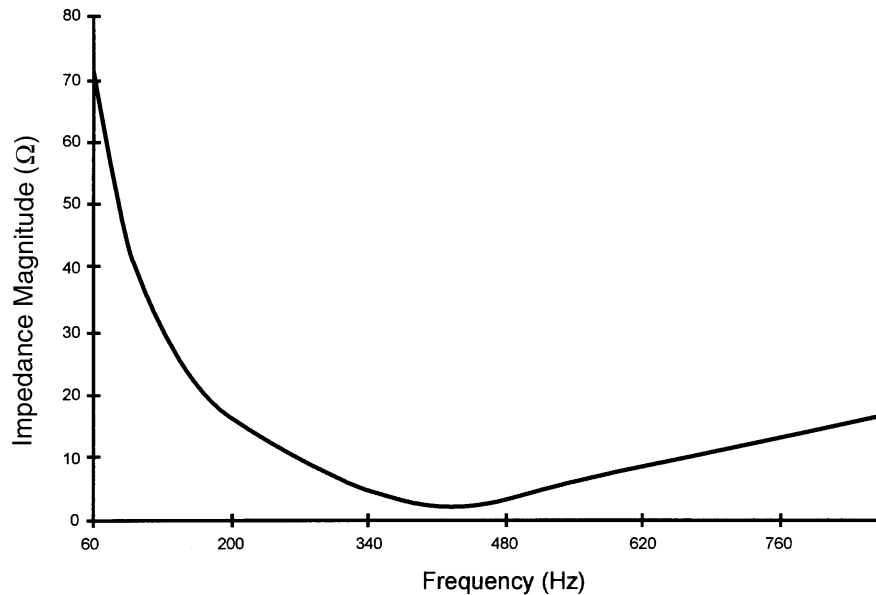

Figure 10-2—Impedance magnitude vs. frequency for series resonant circuit

(>100 at resonant frequency). In special applications it may be necessary to intentionally reduce the Q .

Typical situations where series resonance can be a problem are shown in the one-line diagrams of Figure 10-3. In Figure 10-3 (a), the utility supply is assumed to contain voltage harmonics. The series resonant path is created from the equivalent series impedance from the utility supply and the bus transformer and the power factor correction capacitor. In Figure 10-3 (b), the harmonics are generated inside the plant. The series resonant path involves the two transformer impedances and the PF correction capacitor.

This transformer-capacitor combination could inadvertently act as a filter, and permit the flow of harmonic current at or near the resonant frequency into the capacitor bank. If unplanned, these currents can lead to blown fuses, inadvertent relay operation, and loss-of-life for the capacitor and the transformer.

10.4.3.2 Parallel resonance

There are many forms of parallel resonant circuits. In general, an inductor must be in parallel with a capacitor to produce parallel resonance. A typical parallel-resonant circuit encountered in power systems is shown in Figure 10-4. Each element is described by its impedance. This circuit is said to be in parallel resonance when $X_L = X_C$ as in the case of series resonance.

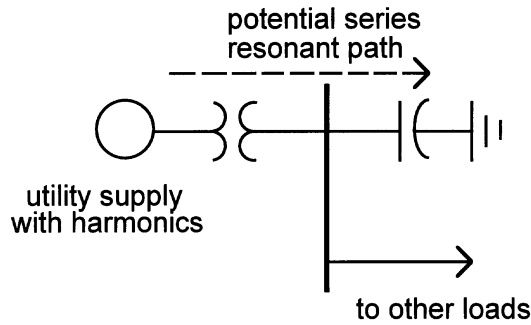

(a) Utility source containing harmonics

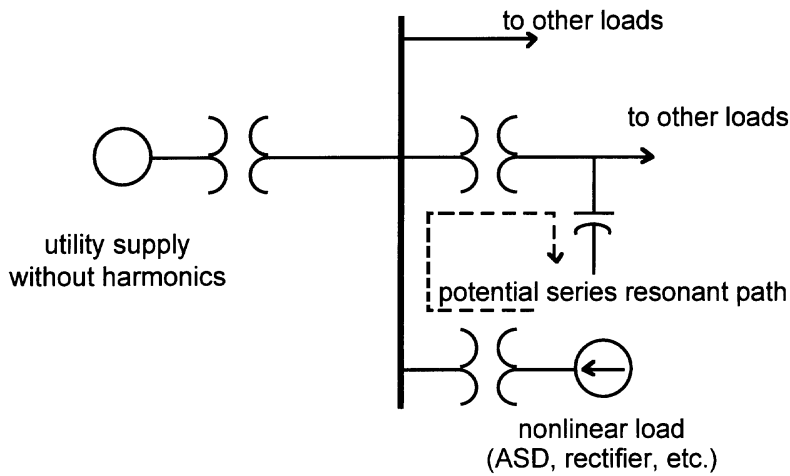

(b) Plant harmonics

Figure 10-3—Potential series resonant situation

The equivalent impedance seen by the current source in Figure 10-4 is given by Equation (10-5). Note that at a particular frequency, $X_L = X_C$ and the denominator is reduced to R . This frequency is the resonant frequency and is given by Equation (10-3). The voltage across the complete circuit is given by equation (10-6).

$$\bar{Z} = \frac{-jX_C(R + jX_L)}{R + j(X_L - X_C)} \quad (10-5)$$

$$\bar{V} = \bar{I} \bar{Z} \quad (10-6)$$

NOTE—Since $Z \gg X_L$ or X_C , V can be very high.

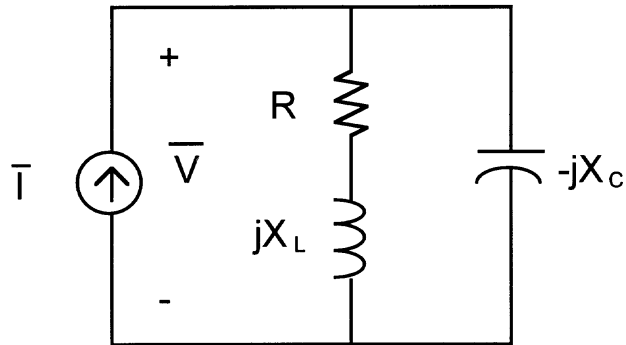

Figure 10-4—Typical parallel resonant circuit

In most cases, the resistance of power circuits is relatively small. It can be seen from Equation (10-5) that resonances can produce very large equivalent impedances at or near the resonant frequency, since R is generally small. Using the previous values ($R = 2 \Omega$, $L = 3.98 \text{ mH}$, and $C = 36.09 \mu\text{F}$), a plot of the magnitude of the impedance in Equation (10-5) is shown in Figure 10-5. The sharpness of Figure 10-5 can be more conveniently calculated by the “current gain factor (ρ , ρ)” as the ratio of current in either the inductive branch or the capacitive branch to the injected current.

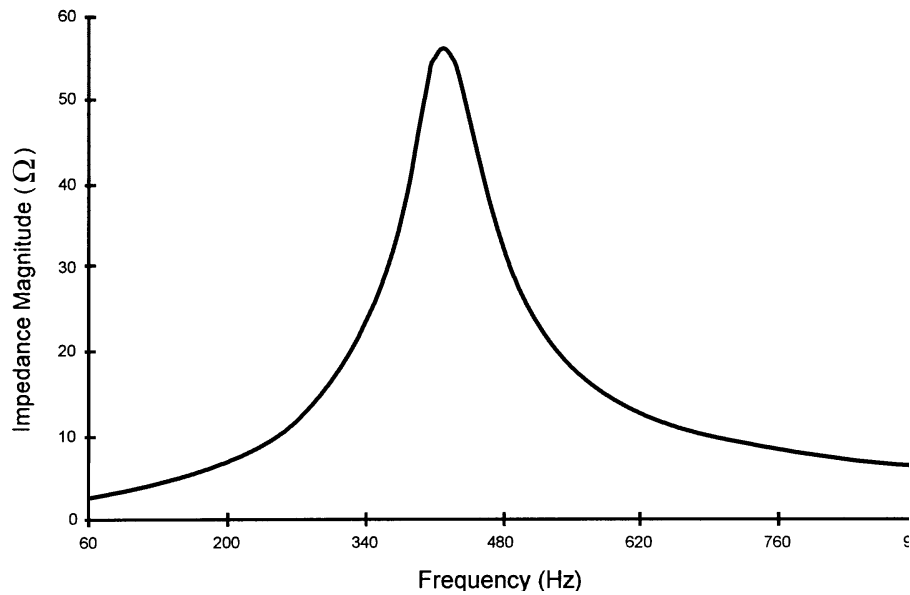

Figure 10-5—Impedance magnitude vs. frequency for parallel circuits

One unique property of the parallel resonant circuit is that when excited from a current source at this frequency, a high circulating current will flow in the capacitance-inductance loop even though the source current is small in comparison. The current in the loop circuit is amplified to a level depending only upon the quality factor Q of the circuit.

Parallel resonance can produce undesirable overvoltages. From Figure 10-4 and Equation (10-6), a current of 1.0 A at 60 Hz will produce a voltage of approximately 2.6 V across the capacitor (the net impedance being capacitive, $Z = 2.55 @ 35.3^\circ$). However, the same 1.0 A current at 420 Hz (near the resonant frequency) will produce approximately 55 V (the net impedance being inductive or close to resistive, $Z = 55.13 @ -10.8^\circ$). This reasoning is often combined with known current injections for motor drives, rectifiers, etc., to predict potential harmonic overvoltages in power systems.

Parallel resonance typically involves the following:

- a) The leakage inductance of large transformers and/or the equivalent inductance of the utility system, and
- b) The power factor correction capacitors. Figure 10-6 shows a possible one-line for parallel resonance.

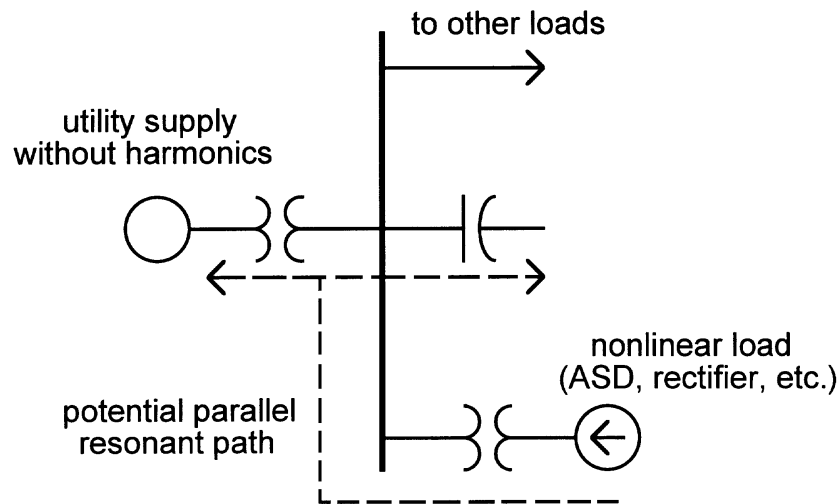

Figure 10-6—Possible parallel resonant circuit: Plant harmonics

10.4.3.3 Resonances due to multiple filters

To illustrate the presence of multiple resonances, Figure 10-7 shows a plot of driving-point impedance as seen from a bus on which three tuned filters (5th, 7th, and 11th), a load, and the system impedance representing the utility are connected in parallel.

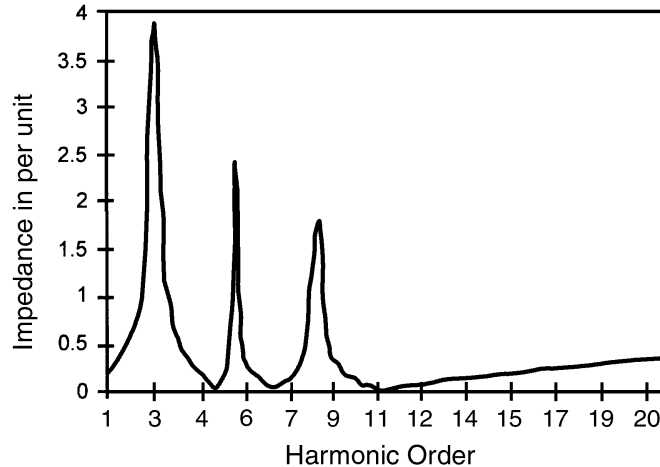

Figure 10-7—Impedance characteristic of multiple tuned filters

It can be seen that there are as many parallel resonance points as there are filters. The first parallel resonant frequency (near the 3rd) is due to system and load impedance, the second resonant frequency is due to the inductive part of the first filter (4.9th) and the capacitive part of the second filter (7th). Similarly, a third resonant frequency occurs between the 7th and 11th. Note that if the filters are tuned at odd harmonics (5, 7, 11), the parallel resonance are likely to occur in between, often midway depending upon the filter sizes.

10.5 System modeling

Harmonic analysis is required when a large number of nonlinear loads (typically greater than 25–30% of the total load on a bus or the system) are present or anticipated to be added. Often PF correction capacitor banks are added without due consideration of resonances, and a study may be required for corrective action. Frequent failure of power system components may also justify the undertaking of harmonic studies. The response of the system to harmonics can be studied by any of the following techniques:

- a) *Hand calculations.* Manual calculations are restrict to small-size networks since it is not only very tedious, but quite susceptible to errors as well.
- b) *Transient network analyzer (TNA).* TNA studies are also restricted to rather small network sizes because these studies are generally found to be expensive and time consuming.
- c) *Field measurements.* Harmonic measurements are often used to determine the individual harmonic and total harmonic distortion in the power system as part of the verification of the design, or compliance with a standard, or simply to diagnose a field problem (see 10.3, last paragraph). The measurements can be used effectively to

validate and refine system modeling for digital simulations, particularly when non-characteristic harmonics are present or a parallel resonance is encountered. Great care should however be taken in using field data for harmonic current injections in digital simulation, if it significantly differs from the calculated values or generally acceptable per-unit values. Measurements of interharmonics require special consideration and instrumentation.

It should be recognized that undertaking harmonic measurements in a systematic fashion can be expensive and time-consuming. Harmonic measurements reflect only the system conditions that they have been taken at, and do not necessarily represent the worst condition. Measurements can be in error due to inaccuracies of measuring instruments or erroneous instrument utilization.

- d) *Digital simulation.* Digital computer simulation is the most convenient method, and perhaps a more economical way of analyzing the system. The reason is that the advent of computer technology has made available quite sophisticated computer programs featuring a large array of system component models to be used in a variety of cases. Computer simulations are based on system-wide approaches utilizing the ideas of system impedance and/or admittance matrices, in conjunction with elegant and powerful numerical calculation techniques.

Chapter 4 of this book deals with system modeling as far as short-circuit, load flow, and transient stability studies are concerned. The short-circuit and load-flow data can also be utilized for harmonic studies. However, the models require additional information to account for frequency dependence. This is because the behavior of the system equipment must be predicted for frequencies well above the fundamental. This subclause summarizes system modeling for harmonic analysis. The models are summarized in Table 10-1. Note that the models and the constants assumed in the equations are just examples, and there can be many other models or constants.

10.5.1 Generator model

Generators of relatively modern design produce no significant harmonic voltages; therefore, they are not harmonic sources and can be represented by an impedance connected to ground. A reactance derived from either subtransient or negative sequence reactances is often used (both having similar values). Negative sequence impedance measurements for small units agree to within 15% as compared with that of the subtransient impedance. In the absence of a better model, and until more results are reported, a simple series RL circuit representing the subtransient reactance with X/R ratio (at fundamental frequency) ranging between 15–50 can be used. However, the generator resistance should be corrected at high frequencies due to skin effect. The following equation is suggested:

$$R = R_{dc}(1.0 + Ah^B) \quad (10-7)$$

where R_{dc} is the armature dc resistance and h is the harmonic order. Coefficients A and B have typical values of 0.1 and 1.5, respectively.

Table 10-1—Power system component models for harmonic analysis

System components	Equivalent circuit model	Model parameters
Synchronous machines		$R = R_{dc}(1 + Ah^B)$ $X = X'' \text{ or } X_2 = \frac{X''_d + X''_q}{2}$
Transformer	 <p>Ignored if not a significant harmonic source</p>	$R_T = R_{dc}(1 + Ah^B)$ <p>R_T and X_T are transformer rated R and X values</p>
Induction machines		$R = R_{dc}(1 + Ah^B)$ $X = X'' \text{ or } X_2 = \frac{X''_d + X''_q}{2}$ <p>NOTE—See 10.5.3 for a more accurate model.</p>
Load	<p>Static load:</p>  <p>Motor load:</p> 	$R = \frac{V^2}{P} \quad X = \frac{V^2}{Q}$ $R = \frac{V^2}{P} \quad X = \frac{V^2}{Q}$

Table 10-1—Power system component models for harmonic analysis (Continued)

System components	Equivalent circuit model	Model parameters
Line and cable	<p>Short line and cable:</p>  <p>Long line (equivalent Pi):</p> 	$M = 0.001585 \sqrt{\frac{f}{R_{dc}}}$ $f = \text{frequency (Hz)}$ $R_{dc} = \text{dc resistance } (\Omega/\text{m})$ $l = \text{length in meters}$ $R = R_{dc} (0.035 M^2 + 0.938), M < 2.4$ $R = R_{dc} (0.35 M^2 + 0.3), M \geq 2.4$ $z = r + jx_L (\Omega/\text{m})$ $y = g + jb_C (S/\text{m})$ $Z_C = \sqrt{\frac{z}{y}}; \gamma_e = \sqrt{zy}$ $Z = Z_C \sinh(\gamma_e l),$ $\frac{Y}{2} = \frac{1}{Z_C} \tanh\left(\frac{\gamma_e l}{2}\right)$
Shunt capacitor		

10.5.2 Transformer model

A transformer can be modeled as an ideal transformer in series with the nominal leakage impedance. The leakage reactance varies linearly with frequency, but proper resistance modeling must account for skin effect. A similar expression to the one used for the generator resistance can be used with similar values of coefficients *A* and *B*. Many variants for the transformer leakage impedance are recommended by CIGRE [B3]. More complex models suggest considering magnetizing reactance, core loss, and the interturn and interwinding transformer capacitances. Since the transformer resonance starts to occur at relatively high frequency, well above the 50th harmonic, capacitances usually are ignored. The magnetizing branch together with the core losses are also neglected in most cases.

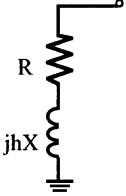
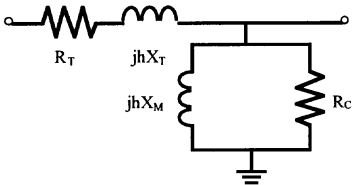
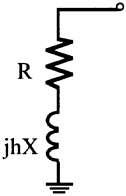
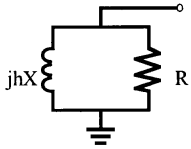
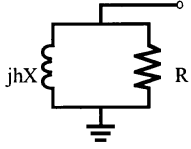
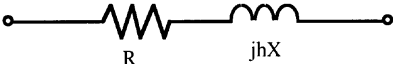
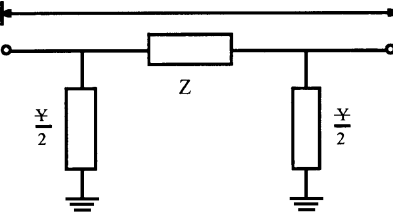
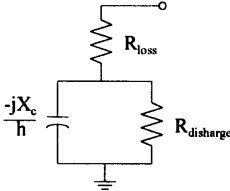
10.5.3 Induction motor model

The standard circuit model of the induction motor, illustrated in Figure 4-17 of Chapter 4, remains valid in harmonic analysis. Here again, the model consists of a stator impedance, a

magnetization branch with a core loss resistance, and a slip-dependent rotor impedance. In harmonic studies, the stator and magnetization branch resistances and inductances are considered independent of frequency. However, considerations are given to the variation of rotor impedance due to skin effect and the definition of an appropriate harmonic slip at frequencies other than the fundamental.

The skin effect is an important factor in assessing the rotor impedance of machines with deep bar rotors or double squirrel cages. At locked rotor, the frequency of the rotor current is high (slip =1). Due to the skin effect, these rotor constructions provide a high rotor resistance and, therefore, increased starting torque. At the nominal load, the frequency of the rotor current is low and the skin effect is negligible. Then the rotor resistance reduces substantially and allows for a more efficient operation. The same can be said for the rotor inductance, although the magnitude of the variation is much less pronounced. For harmonic analysis, this variation of rotor resistance and inductance as function of slip is usually modeled using linear equations. The proportionality coefficients linking the rotor resistance and inductance to the slip are called cage factors. Expressions for rotor resistance and inductance are as follows:

$$R_r(h) = \frac{R_{r0}}{S_h} \times (1 + CR \times S_h) \quad (10-8)$$

$$L_r(h) = L_{r0} \times (1 + CX \times S_h) \quad (10-9)$$

where

- $R_r(h), L_r(h)$ are the frequency dependent rotor resistance and inductance, respectively,
- R_{r0}, L_{r0} are the dc rotor resistance and inductance, respectively,
- CR, CX are the rotor cage factors for rotor resistance and inductance, respectively (typical values are $CR \approx 2$ and $CX \approx -0.01$),
- S_h is the slip at the harmonic frequency.

This rotor model is used in situations where the motor operation forces the rotor currents to span a wide frequency range. This is the case in harmonic analysis.

Each component $1h$ of the harmonic current flowing into the motor will each see an impedance whose value is dictated by the above equations at the appropriate slip. A first expression for that value of the slip (S_h), is obtained from the basic definition of the slip. It states that the slip is the difference between the stator (harmonic) frequency and the rotor electrical frequency divide by the stator frequency.

$$S_h = \frac{\omega_h - \omega_r}{\omega_h} = \frac{h \times \omega_0 - (1 - s) \times \omega_0}{h \times \omega_0} = \frac{h + s - 1}{h} \cong \frac{h - 1}{h} \quad (10-10)$$

where

- h is the harmonic order,

$\omega_h, \omega_r, \omega_0$ are the harmonic angular frequency, the rotor angular frequency, and the synchronous frequency, respectively,
 s is the conventional slip at the fundamental frequency.

We note that, at the higher harmonic orders, the harmonic slip approaches 1, and the resistance and inductance terms become constants. In practice, the harmonic slip can be considered 1 for harmonic orders greater than 9.

Balanced harmonic currents of order $Nk + 1$, $Nk + 2$, and $Nk + 3$ ($k = 0, 1, 2$ for $N = 1, 2, 3 \dots$) have been associated with the positive sequence, negative sequence, and zero sequence, respectively. A negative sequence flux rotates in the opposite direction of the rotor, and the frequency of the rotor flux is the sum of the rotor and stator frequencies. This is taken into account in the expression for harmonic slip by replacing the minus sign as follows:

$$S_h \cong \frac{h \pm 1}{h} \quad (10-11)$$

where

“−” is applied to positive sequence harmonics,

“+” is applied to negative sequence harmonics,

$S_h = 1$ for zero sequence harmonics.

The magnitude of the harmonic slip approaches unity at higher frequencies, and the motor inductance can be approximated by its locked rotor or subtransient value.

10.5.4 Load model

Various models have been proposed to represent individual loads and aggregate loads in harmonic studies. Specific models are available for individual loads, whether they be passive, rotating, solid-state, etc. An aggregate load is usually represented as a parallel/series combination of resistances and inductances, estimated from the fundamental frequency load power. This model can be used to represent an aggregate of passive or motor loads. The model resistance and inductances are considered constant over the frequency range.

10.5.5 Transmission line and cable models

A short line or cable can be represented by a series RL circuit representing the line series resistance and reactance. The resistance must be corrected to take into account the skin effect for higher frequencies. For longer lines, modeling of the line shunt capacitance becomes necessary. Both the lumped parameter model (equivalent pi model for example) and the distributed parameter model are used, but the latter is better suited to represent the line's response over a wide frequency range. The distributed line model can be approximated by cascading several lumped parameter models. Cascading sections of either model to represent a long line is worthwhile to produce a harmonic voltage profile along the line.

The variation of line resistance due to skin effect can be evaluated using the following expression:

$$R = R_{dc}(0.35X^2 + 0.938), X < 2.4 \quad (10-12a)$$

$$R = R_{dc}(0.35X + 0.3), X \geq 2.4 \quad (10-12b)$$

$$\text{where } X = 0.001585 \left(\frac{f}{R_{dc}} \right)^{0.5} \quad (10-13)$$

and f is frequency in Hz, and R_{dc} is in Ω/mi .

10.5.6 Filter models

Filters, by definition, exhibit small impedances at tuned frequencies. At the fundamental frequency, their impedance is capacitive, thereby supplying reactive power to the electrical network. Many types of filters are applied in power systems for different purposes. Filters most commonly used for harmonic mitigation are illustrated in Figure 10-8 along with their characteristics. A single-tuned filter is used to suppress a specific harmonic at or near the tuned frequency. High-pass filters can be of first, second, or third order. The second-order filter is often used to suppress higher frequencies. A more recent type of high-pass filter, called C-type filter, is becoming popular due to its smaller losses at the fundamental frequency.

Application of filters is one of the commonly employed solutions to limit the effects of harmonics. Other remedial measures such as moving the disturbing loads to higher voltage levels, reinforcing the system, changing capacitor sizes, and adding tuning reactors to capacitor banks are also used. In any case, economics will dictate the most appropriate solution. Recent studies advocate the utilization of active filtering in an effort to counter the injected harmonics close to the source, but primarily in low-voltage systems.

10.5.7 Network modeling and computer-based solution techniques

Although several methodologies have been tried successfully, the most common methodology of harmonic analysis is the current injection method. In this method, nonlinear loads are modeled as ideal harmonic current sources. Each network element is represented by a set of linear equations corresponding to its previously described circuit. Using Ohm's law and Kirchoff's laws, all the network elements and loads are connected according to the network topology. Mathematically this operation generates an equation at each bus of the network. At bus i , connected to a set of buses j , we have the following:

$$\left[\sum_j Y_{ij} \right] \times V_i = I_i + \sum_j (Y_{ij} \times V_j) \quad (10-14)$$

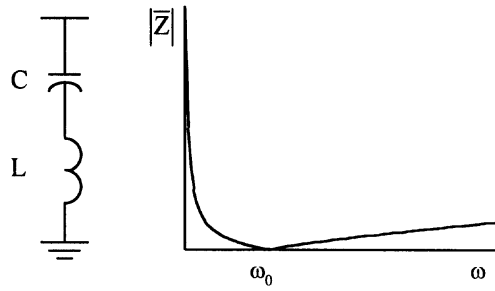

(a) Single-tuned filter

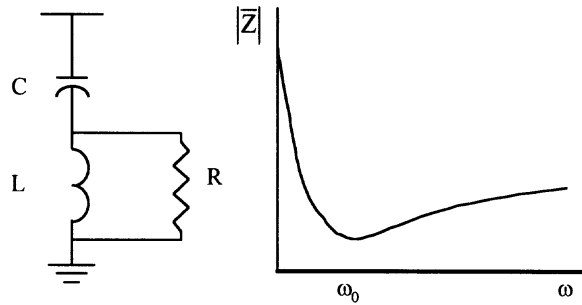

(b) High-pass filter (second order)

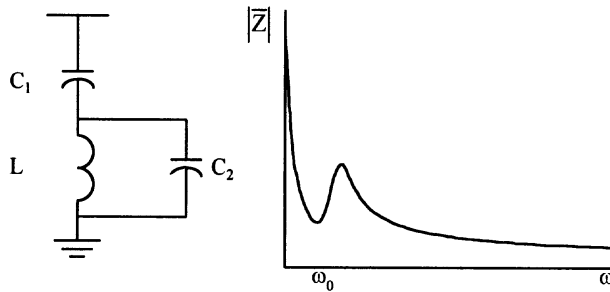

(c) Undamped high-pass filter (third order)

Figure 10-8—Filters commonly used for harmonic mitigation

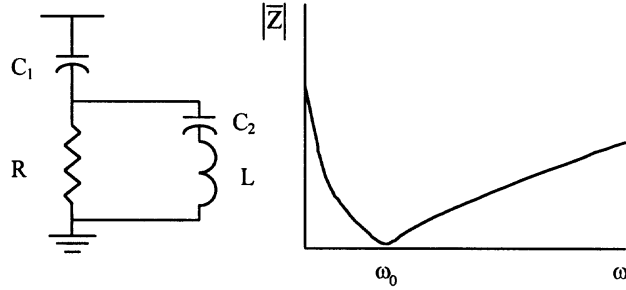

(d) High-pass C-type filter (third order)

Figure 10-8—Filters commonly used for harmonic mitigation (*Continued*)

In matrix form, the set of n equations, denoted compactly as $YV = I$, takes on the form

$$\begin{bmatrix} Y_{11} & -Y_{12} & \cdots & -Y_{1n} \\ -Y_{12} & Y_{22} & \cdots & -Y_{2n} \\ & & \cdots & \\ -Y_{1n} & -Y_{2n} & \cdots & Y_{nn} \end{bmatrix} \begin{bmatrix} V_1 \\ V_2 \\ \cdots \\ V_n \end{bmatrix} = \begin{bmatrix} I_1 \\ I_2 \\ \cdots \\ I_n \end{bmatrix} \quad (10-15)$$

The diagonal elements Y_{ii} of the matrix are the sums of the admittances connected to the bus. The off-diagonal element Y_{ij} is equal to (-1) times the admittance connected between buses i and j . The above equation may be expressed in words as follows:

{[The sum of the admittances connected to bus i] multiplied by the voltage V_i } is equal to the sum of the [(admittances ij taken one by one) multiplied by the corresponding voltages V_j at the adjacent buses] plus the current I_i injected at bus i .

By solving this system of equations, we obtain the nodal voltages. This computation is performed for each harmonic frequency of interest. From the harmonic voltages we can compute the harmonic currents in each branch:

$$I_{ij} = (V_i - V_j) \times Y_{ij} \quad (10-16)$$

The bulk of the work is in forming the network equations. Excellent linear equation solvers are readily available.

The inverse of the nodal admittance matrix is called the nodal impedance matrix. This matrix is rich in quantitative information. The diagonal entry on the i th row is the Thevenin impedance of the network seen from bus i . By computing values of this matrix over a range of

frequencies, we obtain the frequency response of the network seen from each bus. Exact resonance frequencies can be determined from this computation. The off-diagonal values in the matrix show the effect of a harmonic current injection on the bus voltages. Consider a single harmonic source connected at bus i forcing 1.0 A of current into the network. The harmonic voltage at bus j is simply Z_{ij} , the value found in the i th row and j th column of the nodal impedance matrix. The harmonic voltage at bus j due to numerous sources can be solved by superposition.

The total harmonic distortion, the rms value, the telephone interference factor, and related factors (VT and IT) are readily computed from the harmonic voltage or current (U_n) and the fundamental frequency (U_1) quantities as follows:

$$\text{Total harmonic distortion (THD)} = 100 \frac{\sqrt{\sum_{n=2}^{\infty} V_n^2}}{V_1} \quad (10-17)$$

where n is the harmonic order and usually the summation is made up to the 25th or the 50th harmonic order.

$$\text{rms value: } U_{\text{rms}} = \sqrt{\sum_{n=1}^{\infty} V_n^2} \quad (10-18)$$

$$\text{VT or IT: } UT = \sqrt{\sum_{f=0}^{\infty} (K_f \times P_f \times V_f)^2} \quad (10-19)$$

where U designates either voltage or current.

$$\text{Telephone interference factor: } \text{TIF} = \frac{\sqrt{\sum_{f=0}^{\infty} (K_f \times P_f \times V_f)^2}}{V} \quad (10-20)$$

where V is the voltage and K_f and P_f are the weighting factors related to hearing sensitivity (IEEE Std 519-1992 and IEEE Std 597-1983). These useful quantities summarize the harmonic analysis into a few quality-related factors.

In harmonic analysis, two impedance calculations are made to study the system characteristics for series and parallel resonances. These are driving point and transfer impedances. The driving point impedance is defined as voltage, calculated at a node i , due to current injected at the same node, in other words:

$$z_{ii} = \frac{V_i}{I_i} \quad (10-21)$$

Since this is the “net” impedance of all circuits seen from that bus, it provides a useful information regarding resonances. By changing the existing circuits (location of capacitors, cables, etc.) or the design of planned filters, the driving point impedance, and hence resonance, can be changed. The concept of transfer impedance is similar to the driving point impedance in that it is defined as the voltage measured at one bus due to current injected at another bus, in other words:

$$z_{ij} = \frac{V_i}{I_j} \quad (10-22)$$

where

z_{ij} is the transfer impedance to bus i ,
 V_i is the voltage measured at bus i ,
 I_j is the current injected at bus j .

The transfer impedance is useful when any location other than the bus where the current is injected is to be evaluated for harmonic voltages.

10.5.8 Harmonic generation

A harmonic flow study requires the knowledge of harmonics generated by nonlinear devices. Depending upon the nature of the device and accuracy required, this can be a task by itself. Very often, typical values are used for most industrial studies. This subject has been dealt with well in IEEE Std 519-1992 and also in Chapters 3 and 4 of Prabhakara, Smith, and Stratford [B30], therefore a detailed treatment is unnecessary here.

A table is provided here, however, for a 6-pulse and multipulse converter as a matter of comparison, and to demonstrate how certain characteristic harmonics can be canceled by phase multiplication. Harmonics generated by a 6-pulse converter for a square wave of 120° duration are well-known (IEEE Std 519-1992). The magnitude of the harmonic current is given by $I_h = I_1/h$, where I_1 is the fundamental current and the harmonic order h is given by $h = kq \pm 1$, where k is an integer and q is the number of pulse.

Table 10-2 indicates that for a 12-pulse converter the 5th harmonic and 7th harmonic are canceled in the ideal case. However, due to system and equipment imbalances (non-ideal behavior), a perfect cancellation does not occur, and in general the current is assumed to be 10–15% of what would be expected (Prabhakara, Smith, and Stratford [B30], Chapter 11), e.g., for a 12-pulse converter, the 5th harmonic would be around 2% instead of 20%.

Figure 10-9 (a) and 10-9 (b) show the conceptual arrangement of 12-pulse and 24-pulse converters using 3-phase, 2-winding transformers. In Figure 10-9 (a) the two rectifier transformers are individually phase-shifted 30° with respect to each other. When viewed from bus A and when they are both equally loaded, they collectively appear to be a 6-phase, 12-pulse system. Similarly in Figure 10-9 (b), buses C and D appear to have 6-phase, 12-pulse rectification but, due to differing connections of the power transformer, the system becomes a

Table 10-2—Characteristic ac line harmonic currents in multipulse systems

Harmonic	Rectifier system pulse number				Harmonic frequency	Harmonic current in percent of fundamental	
	6	12	18	24		Theoretical	Typical
5	X				300	20.00	19.20
7	X				420	14.20	13.20
11	X	X			660	9.09	7.30
13	X	X			780	7.69	5.70
17	X		X		1020	5.88	3.50
19	X		X		1140	5.26	2.70
23	X	X		X	1380	4.36	2.00
25	X	X		X	1500	4.00	1.60
29	X				1740	3.45	1.40
31	X				1860	3.23	1.20
35	X		X		2100	2.86	1.10
37	X		X		2220	2.70	1.00

NOTE—The theoretical values are given for a 6-pulse converter with ideal characteristics (i.e., square current waves with 120° conduction). The last column gives typical values based on a commutating impedance of 0.12 pu and a firing angle of 30° and infinite dc reactor (IEEE Std 519-1992, Table 13.1). These values are on the basis of one 6-pulse converter or all converters, assuming that the harmonics are additive. Since some harmonics will be canceled, but not entirely, a small percentage value may be assumed, as explained earlier in this subclause. Note that if the dc reactor is not large, some of the harmonics can be greater than typical (or theoretical) and some smaller.

12-phase, 24-pulse system viewed from bus B. This configuration will greatly reduce all generated harmonics below the 23rd, compared to 6-pulse systems.

10.5.9 Harmonic analysis for industrial and commercial systems

The purpose of a harmonic study was discussed in 10.3. The following summarizes the steps normally required for a harmonic study in the industrial environment:

- Prepare a system one-line diagram. Note that it is important to include capacitor banks and long lines and cables within the industrial system or the utility system near the point of common coupling (PCC).
- Gather equipment data and ratings (see 10.5.9).
- Obtain the locations of nonlinear loads and the generated harmonic currents.

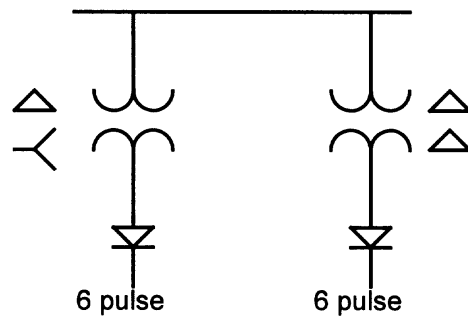

(a) 12-pulse converter arrangement

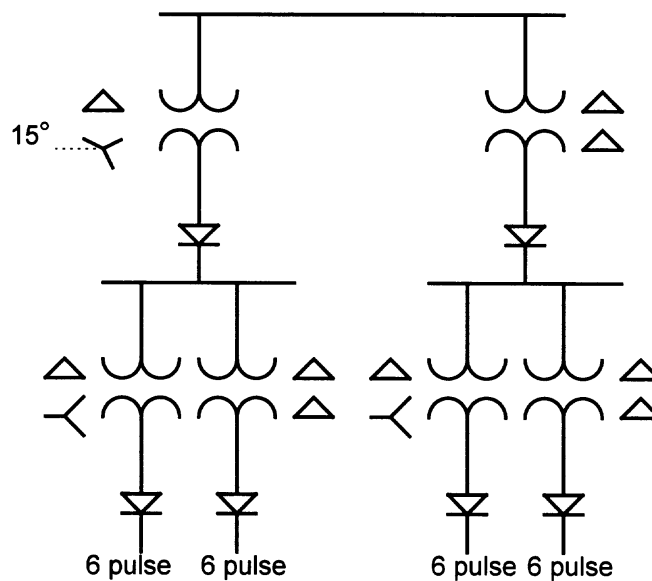

(b) 24-pulse converter arrangement

Figure 10-9—Multipulse converter arrangements

- d) Obtain from the utility company the relevant data and harmonic requirements at the PCC. These should include the following:
- 1) Minimum and maximum fault levels or preferably system impedances as a function of frequency for different system conditions.
 - 2) Permissible limits on harmonics including distortion factors and IT factor. The criteria and limits vary considerably from country to country. Typical values for different system voltages are given in IEEE Std 519-1992.

- e) Carry out harmonic analysis for the base system configuration by calculating the driving point impedance loci at the harmonic source buses as well as at all shunt capacitor locations.
- f) Compute individual and total harmonic voltage and current distortion factors and IT values (if required) at the point of common coupling.
- g) Examine the results and, eventually, go back to step a) or step c), depending on whether the network data or only the parameters of the analysis need to be modified.
- h) Compare the composite (fundamental plus harmonic) loading requirements of shunt capacitor banks with the maximum rating permitted by the standards. IEEE Std 18-1992 has defined the following operating limits:
 - Continuous operating voltage $\leq 110\%$ of the rated voltage
 - rms crest voltage ≤ 1.2 times the rated rms voltage
 - kvar $\leq 135\%$ of the rated kvar
 - Current $\leq 180\%$ of the rated rms currents
- i) Relocate the capacitors or change the bank ratings if they are found to exceed their ratings. Apply a detuning reactor if a resonance condition is found. Go back to step e). Note that adding a tuning reactor will increase the fundamental voltage on the capacitor and may also increase harmonic voltage. The capacitor duty must be satisfied as given in h).
- j) Add filters if the harmonic distortion factors and IT values at the PCC exceed the limit imposed by the utility.

The above steps should be carried out for the base system configuration as well as for system topologies resulting from likely contingencies. Any future system expansion and utility short-circuit level changes should also be considered.

10.5.10 Data for analysis

The following data are required for a typical study:

- a) A single-line diagram of the power system to be studied.
- b) The short-circuit capacity and X/R ratio of the utility power supply system. The existing harmonic voltage spectrum of the utility system at the PCC (external to the system being modeled).
- c) Subtransient reactance and kVA of all rotating machines. If limitations exist, all machines on a given bus can be lumped together into one composite equivalent machine.
- d) Reactance and resistance of all lines, cables, bus work, current limiting reactors, and the rated voltage of the circuit in which the circuit element is located. The units can be either in per-unit or percent values, or ohmic values, depending on the software used or preference.
- e) The three-phase connections, percent impedance, and kVA of all power transformers.
- f) The three-phase connections, kvar, and unit kV ratings of all shunt capacitors and shunt reactors.

- g) Nameplate ratings, number of phases, pulses, and converter connections, whether they are diodes or thyristors, and, if thyristors, the maximum phase delay angle, per unit loading, and loading cycle of each converter unit connected to the system. Actual manufacturer's test sheets on each converter transformer are also helpful but not absolutely mandatory. If this information is not readily available, the kVA rating of the converter transformer may be used for establishing the harmonic current spectrum being injected into the system.
- h) Specific system configurations.
- i) Maximum expected voltage for the system supplying the nonlinear loads.
- j) For arc furnace installations, secondary lead impedance from the transformer to the electrodes plus a loading cycle to include arc megawatts, secondary voltages, secondary current furnace transformer taps, and transformer connections.
- k) Utility-imposed harmonic limits at the PCC, otherwise limits, as specified in applicable standards, may be used.

10.6 Example solutions

Several applications of harmonic studies are presented in this subclause. Frequency scans, capacitor effects, and filter design are demonstrated. Each example uses a variation of the simple system provided in 10.6.1.

10.6.1 Test system single-line diagram and data

The diagram in Figure 10-10 is used for all examples in 10.6. This system is representative of an industrial power system and includes multiple voltage levels and power factor correction capacitors. The data required for basic harmonic studies are provided in Tables 10-3, 10-4, and 10-5.

The capacitor banks have been sized to provide a power factor of 0.95 lagging at the low-voltage side of each transformer and may consist of series and parallel units. As previously mentioned, the modeling of motor load for harmonic studies is not, in most cases, significantly different from static load; therefore, the total load given in Table 10-5 for each bus includes both types.

10.6.2 Case Study 1: Diode rectifier on 33 kV bus

The impacts of a proposed adjustable-speed motor drive installed at the 33 kV bus are to be determined. The switches connecting the 33–6.6 kV transformer are open in this case study; therefore, the 6.6 kV bus is not considered for this case (refer to 10.6.3 for Case Study 2, where the switch is considered closed). The harmonic source, shown in Figure 10-10 as a current source, is a standard diode rectifier supplying 25 MW on the dc side. A frequency scan is performed at the 33 kV bus, and the resultant driving point impedance is shown in Figure 10-11. Note the distinct impedance peak (indicating a resonant point) near the 8th harmonic (480 Hz).

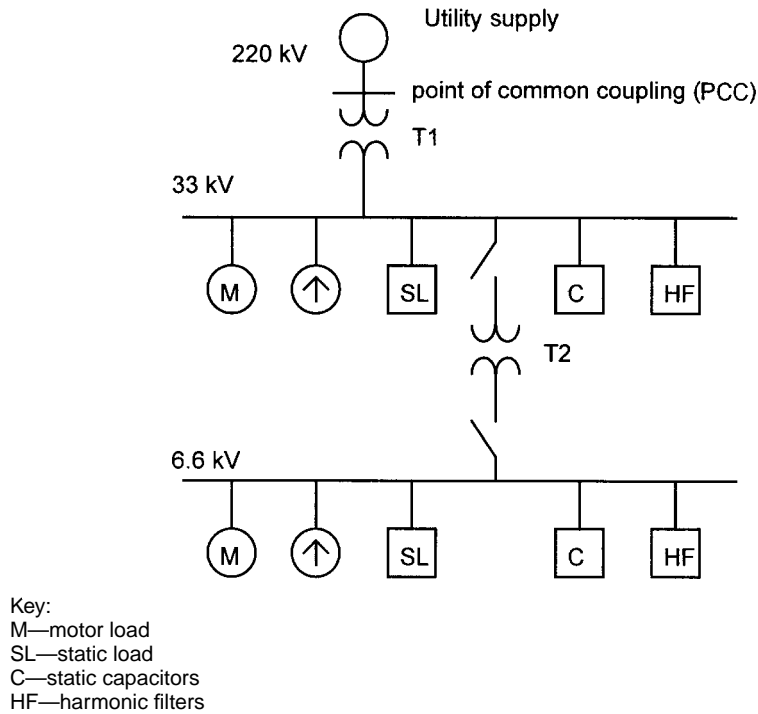

Figure 10-10—Example system for harmonic studies

Table 10-3—Utility supply data

Parameter	Value
Supply voltage	220 kV
Short-circuit capacity	4000–10 000 MVA
X/R	20.0

Table 10-4—Transformer data

Parameter	T_1	T_2
Power rating (MVA)	100	30
Voltage rating (kV)	220–33	33–6.6
Impedance (%)	14	10
X/R	10.0	10.0

Table 10-5—Load and capacitor data

33 kV bus	Linear load	25 MVA @ 0.8 lag
	Converter	25 MW
	Capacitor	8.4 Mvar
6.6 kV bus	Linear load	15 MVA @ 0.8 lag
	Converter	15 MW
	Capacitor	5 Mvar

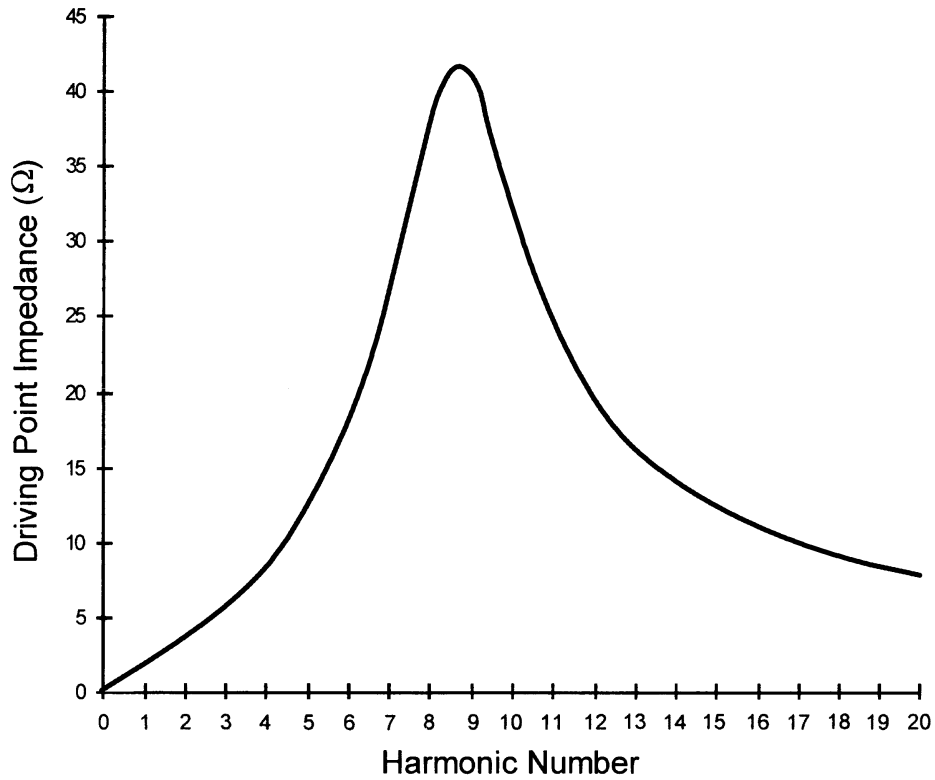

Figure 10-11—Driving point impedance at 33 kV bus

The impacts of this resonance condition are determined using multiple solutions (one solution at each frequency of interest) of the set of nodal equations for the system. The harmonic content of the diode rectifier current (on the ac side) is given in Table 10-6. Figures 10-12 (a) and 10-12 (b) and 10-13 (a) and 10-13 (b) show the voltage waveforms and harmonic magnitude spectra (including approximate voltage THDs) at the 33 kV and 220 kV buses, respectively. Note that these are computed waveforms.

Table 10-6—Harmonic content of diode rectifier current (ac side)

Harmonic number	Frequency (Hz)	Magnitude (A)	Phase (degrees)
1	60	618	0
5	300	124	180
7	420	88	0
11	660	56	180
13	780	47	0
17	1020	36	180
19	1140	33	0

10.6.3 Case Study 2: Effects of including the 6.6 kV bus

This study is identical to that of 10.6.2 except that the switches to the 33–6.6 kV transformer are closed resulting in the connection of the 6.6 kV bus to the system. A frequency scan is again conducted at the 33 kV bus, and the resultant driving point impedance is shown in Figure 10-14. Note the presence of two resonance points. This is to be expected because there are typically the same number of resonance points as number of capacitors.

The impacts of the resonance points on voltage waveforms are shown in Table 10-7 where the diode rectifier load on the 33 kV bus is given in 10.6.2. Harmonic content and approximate voltage THD values are given for the 6.6, 33, and 220 kV buses. Relative to the case in 10.6.2, the distortion is worse at the 33 kV bus but not as bad at the 220 kV bus.

10.6.4 Case Study 3: Motor drive on the 6.6 kV bus

The impacts of a proposed motor drive installed on the 6.6 kV bus are to be determined. The 33–6.6 kV transformer switches are closed providing the connection to the supply voltage. A diode rectifier delivering 15 MW (with the same harmonic current content as given previously for the 33 kV rectifier) on the dc side represents the drive. The rectifier load used in 10.6.2 and 10.6.3 at the 33 kV bus is not present in this study.

The results of a frequency scan conducted at the 6.6 kV bus are shown in Figure 10-15. Note the multiple resonant frequencies near the 6th (360 Hz) and 12th (720 Hz) harmonics. The impacts of the resonance points on voltage waveforms are shown in Table 10-8.

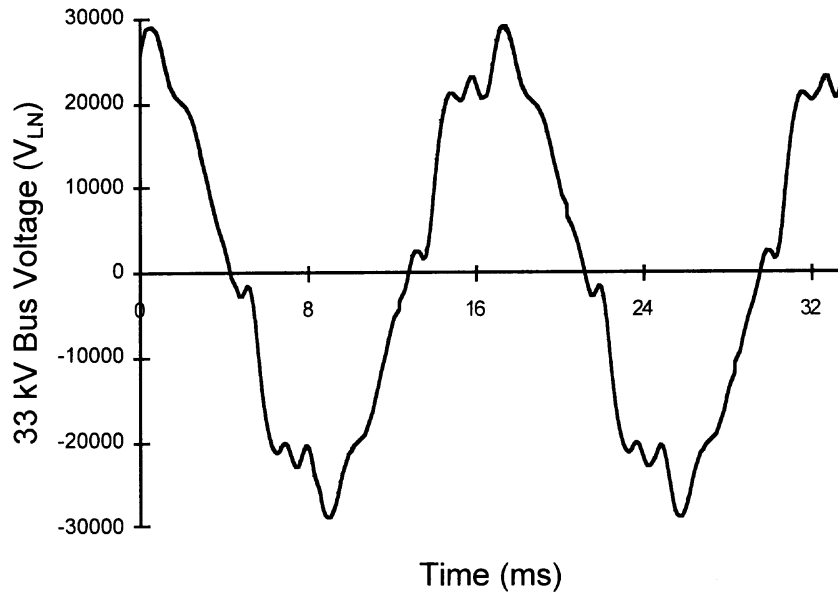

(a) Voltage waveform

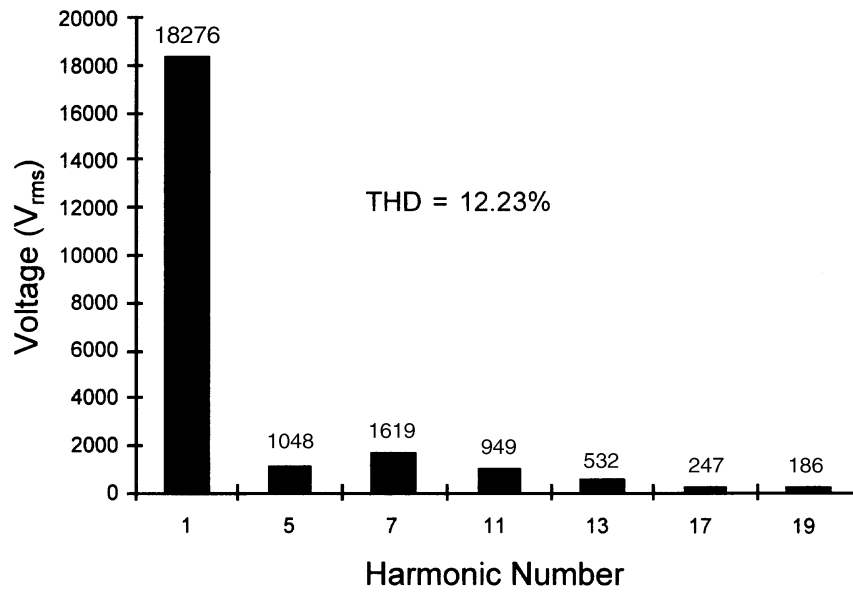

(b) Harmonic magnitude spectrum

Figure 10-12—Line-to-neutral voltage waveform at 33 kV bus

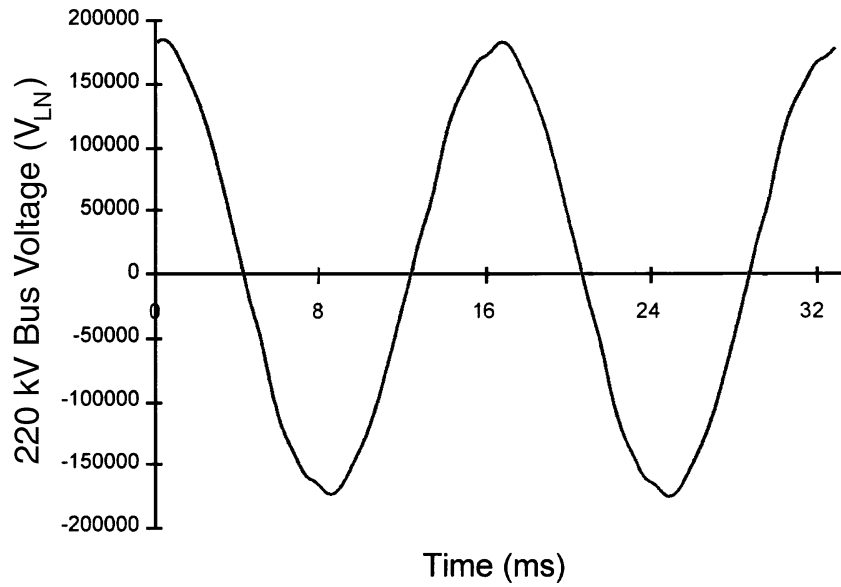

(a) Voltage waveform

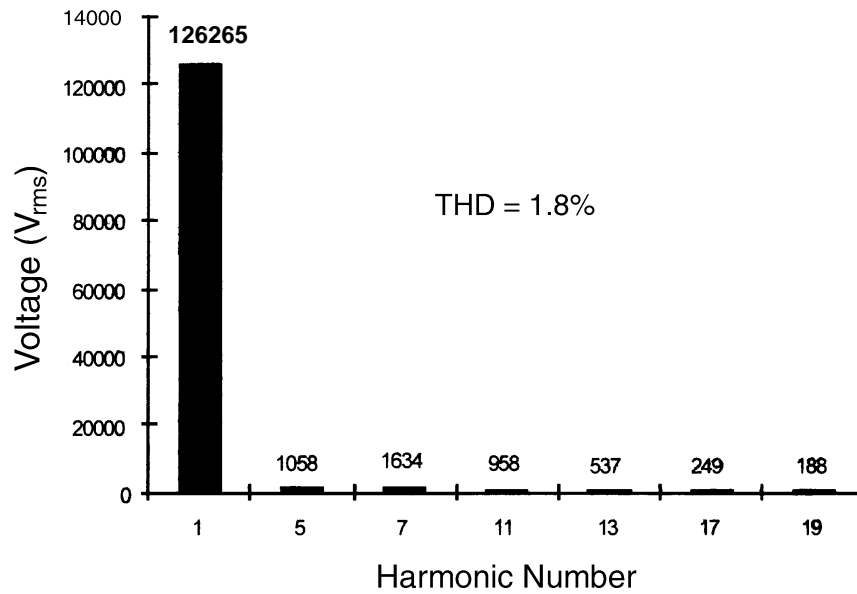

(b) Harmonic magnitude spectrum

Figure 10-13—Line-to-neutral voltage waveform at 220 kV bus

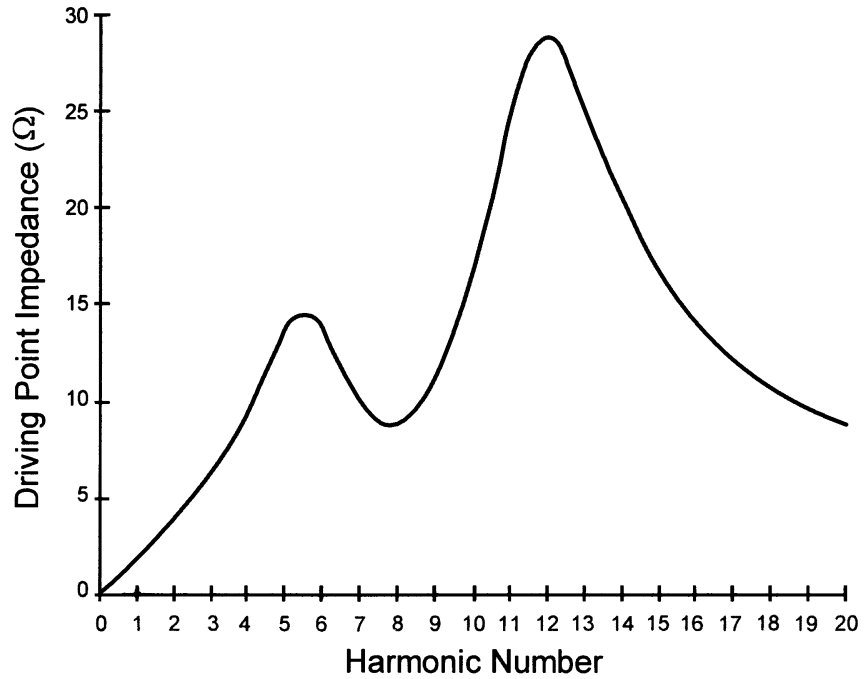

Figure 10-14—Driving point impedance at 33 kV bus

Table 10-7—Harmonic content of bus voltages including the effects of the 6.6 kV bus

Harmonic number	Frequency (Hz)	220 kV bus	33 kV bus	6.6 kV bus
1	60	126 090	18 108	3559
5	300	1 125	1 114	329
7	420	606	600	278
11	660	945	936	166
13	780	818	810	85
17	1020	303	300	15
19	1140	216	214	8
	THD (%)	= 1.448	= 9.989	= 13.188

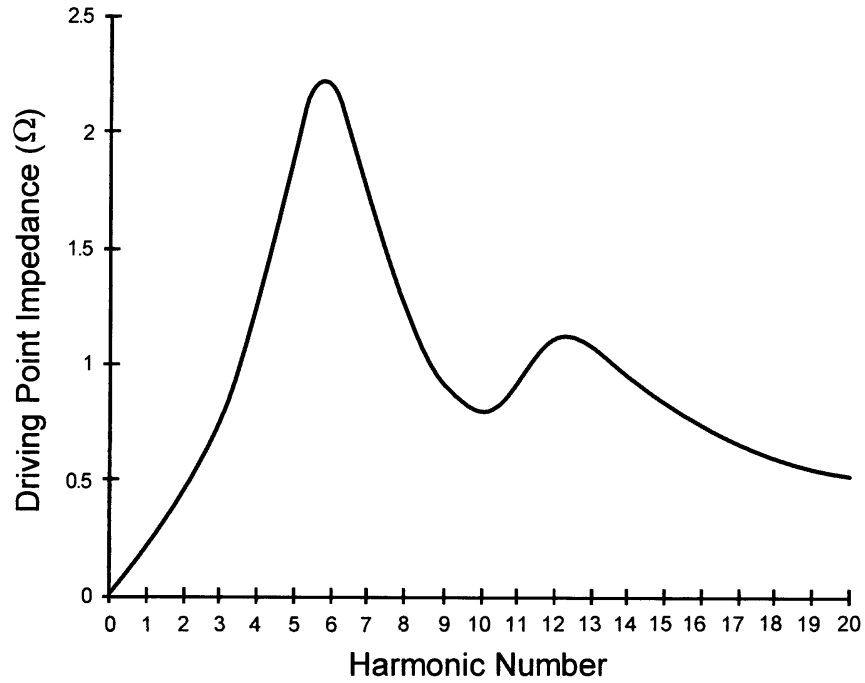

Figure 10-15—Driving point impedance at 6.6 kV bus

Table 10-8—Harmonic content of bus voltages:
Motor drive at 6.6 kV bus

Harmonic number	Frequency (Hz)	220 kV bus	33 kV bus	6.6 kV bus
1	60	126 296	18 307	3 476
5	300	956	947	461
7	420	807	799	294
11	660	482	477	101
13	780	248	246	100
17	1020	45	45	47
19	1140	25	24	35
	THD (%)	= 1.081	= 7.383	= 16.339

10.6.5 Case Study 4: Evaluation of harmonic limits

The analysis of the supply voltage and current assuming that the nonlinear loads at the 33 and 6.6 kV buses are both operating is presented in this case study. This type of study is often required to demonstrate compliance with harmonics limits imposed by the utility company serving the facility.

Figures 10-16 and 10-17 show the input current and voltage waveforms at the PCC where harmonic limits are to be satisfied. The frequency contents of the waveforms are given in Table 10-9, including approximate THD values. For compliance evaluation purposes, an average (typically over a one-year period) maximum demand of 80 MVA is assumed, and this figure is used to express the existing current harmonics as percentages of the maximum demand current as required in IEEE Std 519-1992. Based on this assumption, the recommended limits from IEEE Std 519-1992 are also provided in Table 10-9 and clearly indicate violations of harmonic limits. For line currents, the concept of total demand distortion (TDD) is used in place of THD to account for the use of the percentages in terms of average maximum demand instead of in terms of the fundamental component. All voltage harmonics are expressed in percentages of the fundamental component and THD is used. Even though the voltage at the PCC is near compliance, significant voltage distortion is present inside the plant at the 33 and 6.6 kV buses.

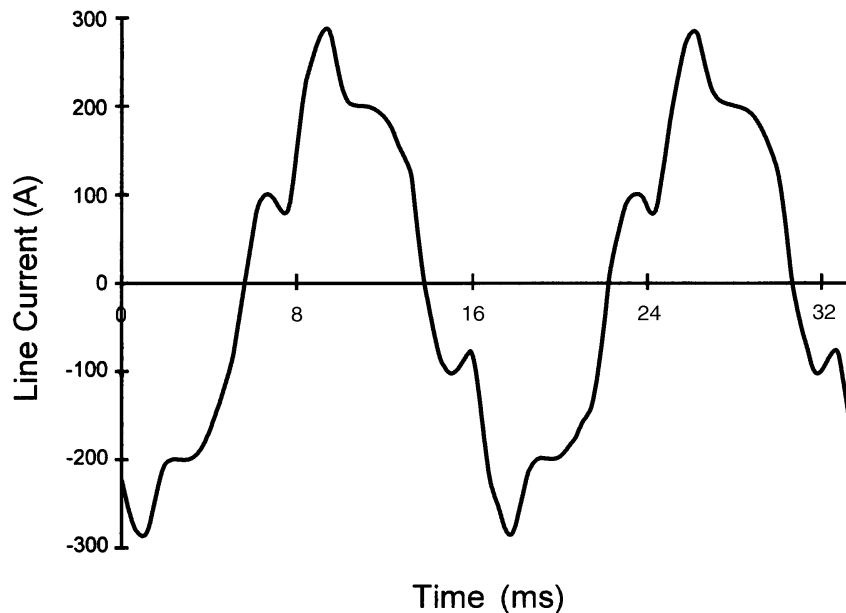

Figure 10-16—Line current at PCC

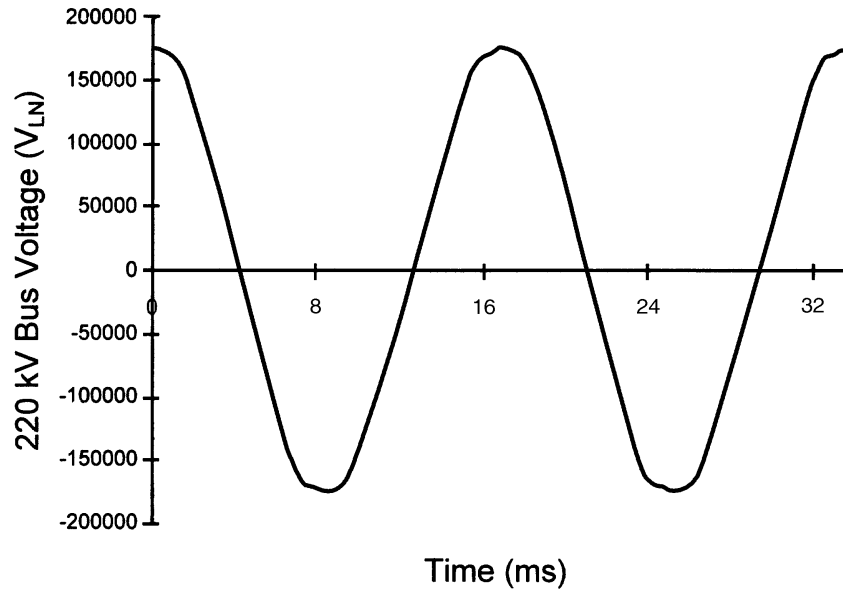

Figure 10-17—Line-to-neutral voltage at PCC

Table 10-9—Harmonic limit evaluation at PCC

Harmonic number	Actual harmonic current magnitudes (percent of average maximum demand current)	Limits for harmonic current magnitudes (percent of average maximum demand current)	Actual harmonic voltage magnitudes (kV _{LN, rms})	Limits for harmonic voltage magnitudes (percent of fundamental)
1	N/A	N/A	125.8	N/A
5	15.0	3.0	1.9	1.0
7	5.8	3.0	1.03	1.0
11	1.7	1.5	0.48	1.0
13	1.8	1.5	0.60	1.0
17	0.6	1.15	0.27	1.0
19	0.4	1.15	0.20	1.0
	THD = 16.3%	TDD = 3.75%	THD = 1.85%	THD = 1.5%

It should be noted that different countries specify different harmonic limits at different points in the system. The use of methods and limits set forth in IEEE Std 519-1992 are used here for consistency. If required, other governing limits and methods should be used in place of those given here.

10.6.6 Representation of the utility system

It is important to consider the effects of variations of the utility supply fault MVA on the frequency response of the industrial system. For this study, the 33–6.6 kV transformer and therefore the entire 6.6 kV bus is disconnected. Figure 10-18 shows a portion of the frequency scan results for the example system. The utility fault MVA is varied from its minimum (4000 MVA) to its maximum (10000 MVA) with the system X/R (@ 60 Hz) held constant at 20.0. The plots show the general trend of an increase in resonant frequency as the utility fault MVA increases. The conclusion is that industrial systems connected to very strong utility supplies (high fault MVA) are less likely to encounter problematic resonance conditions at low frequencies.

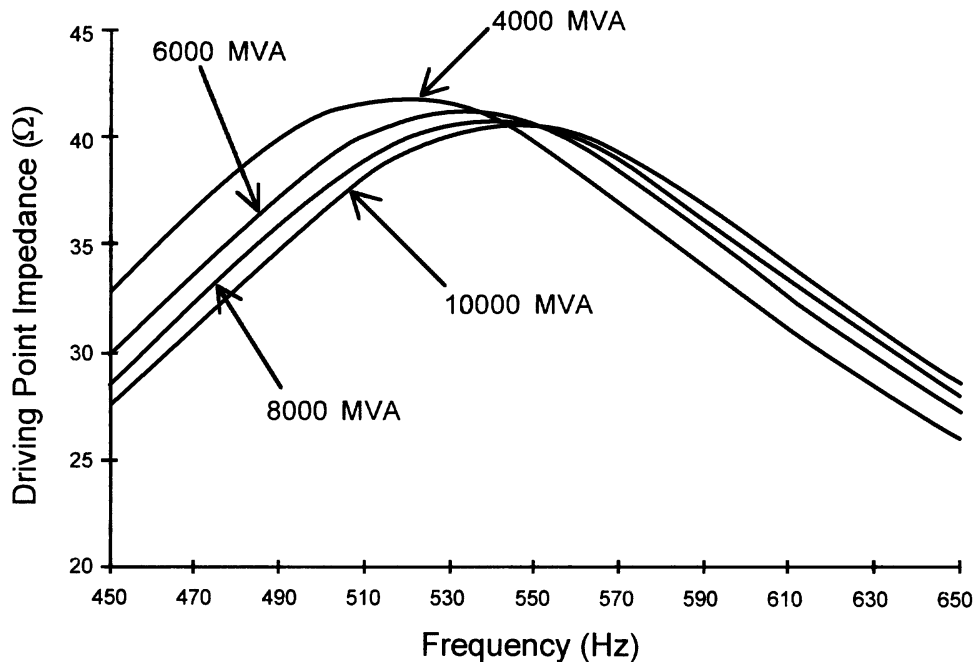

Figure 10-18—Frequency response at 33 kV bus as a function of utility fault MVA

10.6.7 Effects of size of power factor correction capacitors

Power factor correction capacitors are applied in most systems to help achieve lower cost operation. It is important to consider variations in the frequency response due to the size of power factor capacitors. For this study, the 33–6.6 kV transformer and the 6.6 kV bus are disconnected. The utility fault MVA is constant at 4000 MVA, $X/R = 20.0$ (@ 60 Hz). Figure 10-19 shows the variations in the driving point impedance at the 33 kV bus as a function of capacitor bank size.

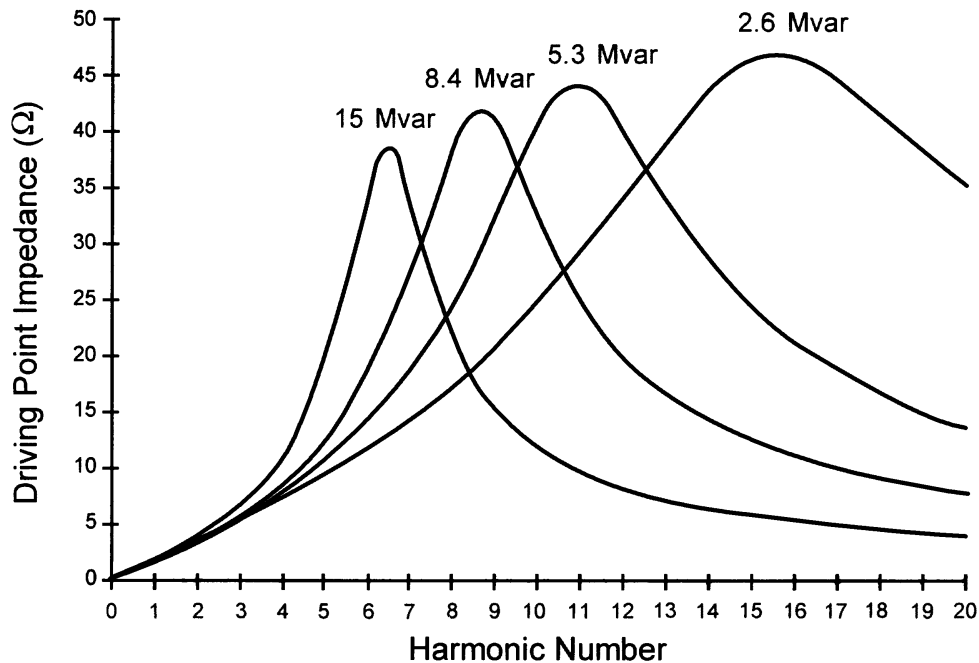

Figure 10-19—Variations in frequency response at 33 kV bus as a function of capacitor bank size

The plots reveal, first, that resonant frequency decreases as capacitor bank size (and therefore power factor) increases, and second, that peak resonant impedance increases as capacitor bank size (and therefore power factor) decreases. It should be noted that the tendency of resistive damping to increase with frequency often lessens the effect of increasing resonant impedance.

10.6.8 Single-tuned filter application

The distortion in the waveform of Figure 10-13 (a) for the study conditions of 10.6.2 can be eliminated using one (or more) RLC filters tuned to provide a low impedance path to ground

at the frequencies of interest. As an example of the effects of filter application, a filter is created using a tuning reactor in series with the power factor correction capacitor bank in the study of 10.6.2. From the frequency scan results shown in Figure 10-12, it appears that the resonant point is near the 8th harmonic (480 Hz). The filter could be tuned to eliminate this resonance, but this action would likely produce a new resonance point at a lower frequency that coincides more exactly with the rectifier harmonics. For this reason, filter tuning frequencies should be selected based on removing specific harmonic currents (before they can excite resonant modes) instead of selected the tuning frequency specifically to modify the frequency response. However, because the application of single-tuned filters inherently produces a new, lower-frequency resonant point, it is important to apply the filter at the lowest current harmonic frequency. For the rectifier load, the lowest harmonic frequency is 300 Hz (5th harmonic). Ideally, the filter should be tuned to this frequency, but variations in system parameters (due to utility switching, etc.) are often significant enough to slightly shift the resonant frequency (note Figure 10-18 in 10.6.6). To counter this effect, single-tuned filters are often constructed using a target frequency that is 3–5% below the frequency of the harmonic current that is to be removed.

In most applications, a single-tuned filter is created using the existing power factor correction capacitors. At power frequencies (50–60 Hz), the series RLC combination appears capacitive and supplies reactive power to the system. At the tuned frequency, the series impedance of the filter is very low and provides a low impedance path to ground for specific harmonic currents.

For Case Study 1 in 10.6.2, the capacitor bank size is 8.4 Mvar @ 33 kV. Considering a per-phase approach, the appropriate tuning reactor can be calculated using standard formulas. A 5.87Ω reactor ($X/R = 14.3$ @ 60 Hz) is chosen such that the filter is tuned to 282 Hz (“4.7th” harmonic). The frequency response of this single-tuned filter using the specified resistance, inductance, and capacitance is shown in Figure 10-20. Note the very low impedance just below 300 Hz (5th harmonic).

The driving point impedance and the voltage waveform at the 33 kV bus with the filter in place are shown in Figures 10-21 (a) and 10-21 (b), respectively. The THD for the voltage waveform has been reduced from 12.23% for the study case of 10.6.2 to 6.32%. However, a second single-tuned filter (near the 7th harmonic) would be required at the 33 kV bus if it was necessary to meet more stringent voltage distortion limits at this location. In many applications, multiple single-tuned filters (tuned near the frequencies of harmonic currents generated by the loads) are used in conjunction with a high-pass filter to satisfy realistic voltage distortion limits.

10.7 Remedial measures

There are several approaches to remedy the harmonic problem in a system. The following is a general discussion of solutions that are available. An exact solution will depend on whether the system is an existing one or a new system is planned, whether the system is flexible to changes, and whether harmonic filters can be added or existing capacitor banks can be modified.

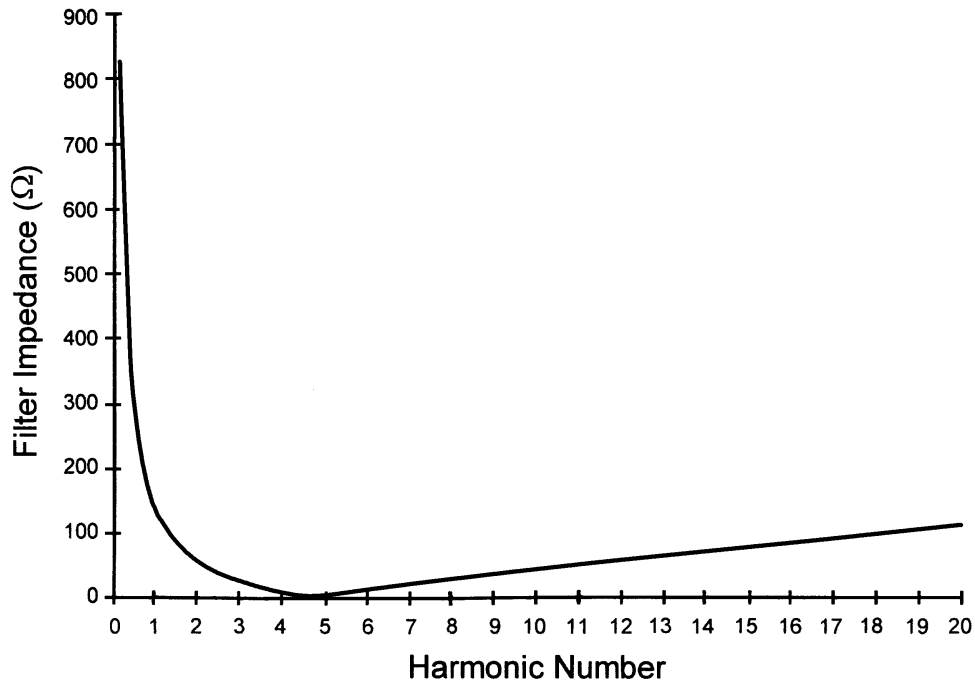
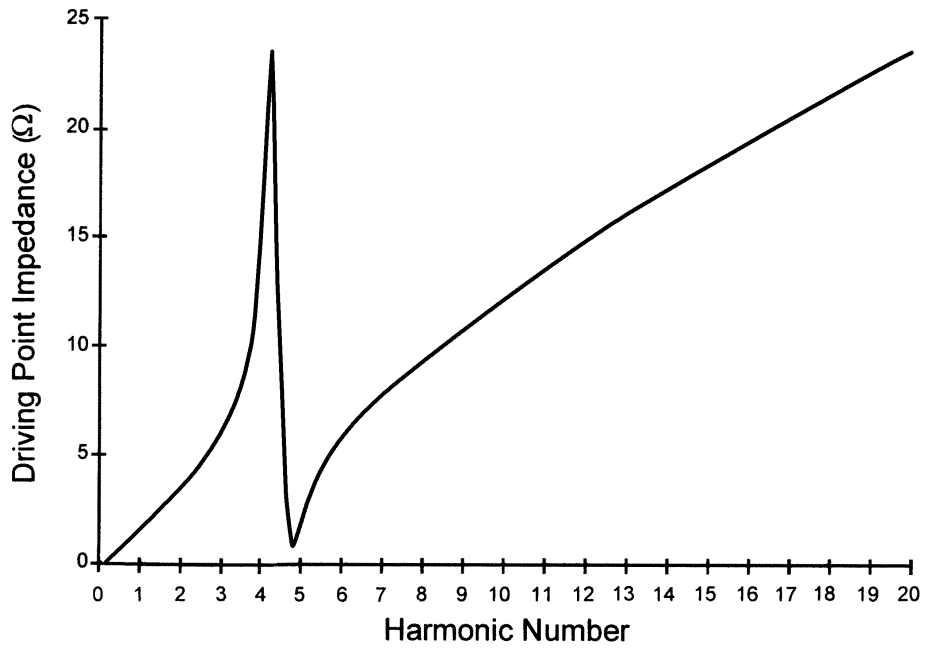
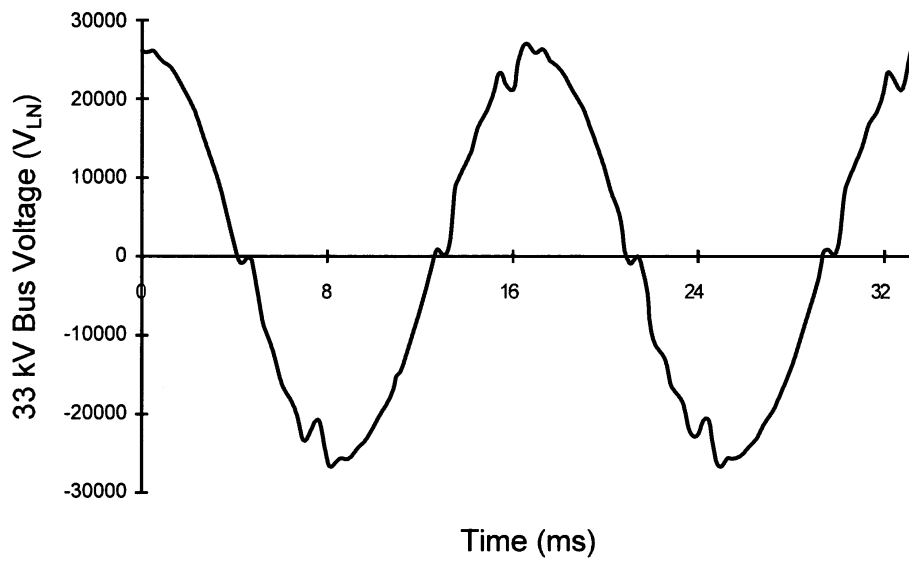

Figure 10-20—Frequency response of single-tuned filter

- a) In designing or expanding a system, care should be taken that the total harmonic load is kept at a relatively low percentage of the total plant load (e.g., 30% would be a good maximum target). If the measured or calculated distortion levels are high, consideration should be given to location of harmonic loads, number of buses, size of the transformers, choice of transformer connections, etc., besides the addition of harmonic filters.
- b) Figure 10-22 shows how the harmonic loads may be separated so that the sensitive loads are not influenced by loads with high harmonics. Note that all heavy loads (in the order of several MVA) should have their own dedicated transformers, e.g., in the case of large drives or arc furnaces in a steel mill. If there are several similar loads, their respective transformers feeding them could be connected in delta and wye alternately to provide some cancellation of certain characteristic harmonics. If the secondary buses are connected together via a tie breaker, precautions should be taken to ensure the harmonic source and sensitive loads are not simultaneously energized during this event.
- c) Multipulsing is a very effective method of reducing harmonics; however, this may not always be possible because of the high cost of transformers. In several industries, rectifiers are often connected with 6-pulse converters to form a 12-pulse, 24-pulse, or higher pulse system, see Figure 10-9. Table 10-10 gives the phase shift needed between bridges to form a multiple system. Note that the harmonic cancellation between bridges is not complete, and a residual harmonic may still be present (see 10.5.8).



(a) Driving point impedance



(b) Line-to-neutral voltage

Figure 10-21—33 kV bus impedance and voltage characteristic with a single-tuned filter

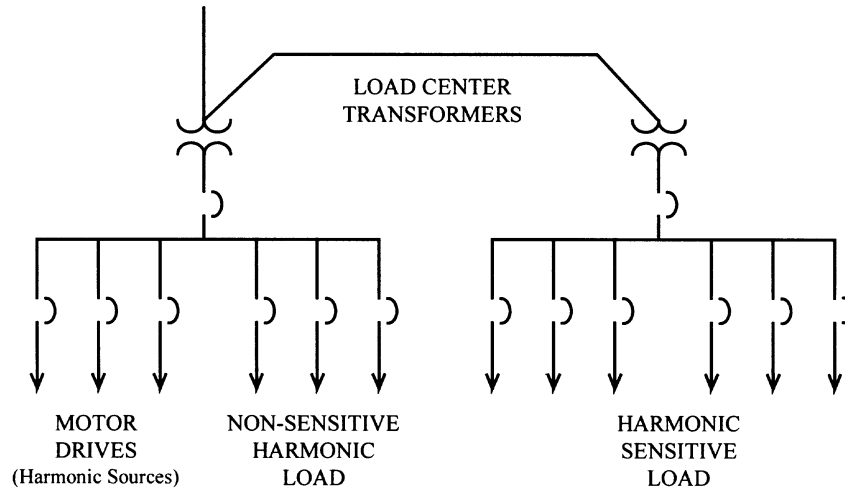

Figure 10-22—Separation of harmonic loads

Table 10-10—Transformer phase shift for various multipulse system

Pulse number	6	12	18	24	30	36	42	48
Number of units	1	2	3	4	5	6	7	8
Phase shift in degrees	0	30	20	15	12	10	8.57	7.5
Lowest harmonic order	5	11	17	23	29	35	41	47

- d) The most common remedial measure for harmonic mitigation is to provide selected harmonic filters tuned to appropriate frequencies. Either existing capacitor banks could be modified to tuned filters by adding tuning reactors, provided the capacitors are adequately rated, or new filter banks could be added. This is discussed in detail in 10.7.1.

10.7.1 Filter selection

Filter selection can be best described as an art rather than a science because there is no single solution. Usually, there are many possible solutions, and the system designer must select the one that best meets the specifications and also make compromises where discretion is required. In industrial systems, multiple single-tuned filters are the most common solutions. However, there may be other types of filters as discussed in 10.5.6. The discussion herein is limited to the procedure of selection rather than the merits and demerits of individual filters. The Working Group on Harmonic Filters under the Capacitors Subcommittee of the Power Engineering Society of IEEE is developing a draft entitled “Guide for Application and Specification of Harmonic Filters.” This draft, not yet in circulation, will be designated as IEEE P1531. It is recommended for further guidance on filters.

The procedure for a harmonic study was discussed in 10.5.9. The study often begins with a preliminary filter design, generally based on past experience, and then refined, as the harmonic performance indices (see 10.5.7 and 10.8) are calculated. In this process of refinement, several steps are involved that determine the number of filters, effective reactive power compensation, and performance indices. Other considerations also enter, such as filter switching and protection, loss of one or more filter banks, and space requirements. One rather obvious design objective is to use as few filters as possible and compare the performance with no filter. Filter location is another consideration. Effective filtering will probably require that the filters be located near harmonic sources. However, economics may dictate that filters be located at higher voltage levels (near the PCC or main bus) to meet the demands of all harmonic sources.

Generally, the filters are tuned at one of the dominant odd characteristic harmonics starting from the lowest order (which in most cases are 5, 7, 11, ...). In some cases the lowest order may be 2 or 3 as in arc furnace applications. Ideally, the filters should be tuned to the exact harmonic order, i.e., 5, 7, 11, etc. however, the practical considerations may require that it is safer to tune below the nominal frequency. If it is necessary to offset the parallel resonance frequency, the filter may be intentionally tuned below or in exceptional cases above the nominal frequency. For example, a 5th harmonic filter may cause a resonance near the 3rd, and it would be desirable to tune it slightly below or above the 5th to offset the resonance at 3rd. Another example is one in which the resonant frequency is very close to the 5th (say at 4.7) for very sharp filters, in which case it will be desirable to tune it below the 5th so that tolerances and temperature deviations, etc., will not let the resonant frequency coincide with the 5th harmonic injection frequency.

The two main components of passive filters, capacitors and reactors, are discussed here. The nominal fundamental kvar rating of the capacitors determines the effectiveness of harmonic filtering. Therefore an initial estimate of the capacitor kvar is very important. The larger the bank size, the easier it is to meet a given harmonic performance criteria. Besides the harmonic requirements, the following additional design factors may need to be considered:

- a) The system power factor (displacement power factor) may be corrected to required or desirable value (usually above 0.9),
- b) The total kVA demand on the supply transformer may have to be reduced if the transformer is overloaded,
- c) Similarly, the current ratings of buses and cables may have to be reduced.

As a general rule, the capacitor needs to be derated in order to absorb the additional duty from the harmonics (a derating factor of 15–20% in voltage would be desirable). Note that because of the derating, the kvar would be reduced by the square of the factor. The loss of kvars is, however, somewhat compensated by the cancellation of the capacitive reactance by the inductive reactance of the filter. The effect of this cancellation is to increase the capacitor voltage (above the bus voltage) by the following factor:

$$c = \frac{h^2}{h^2 - 1} \text{ pu of the fundamental, where } h \text{ is the harmonic order} \quad (10-23)$$

For the conventional single-tuned filter this factor is calculated in Table 10-11.

Table 10-11—Fundamental voltage across a single-tuned filter capacitor

Harmonic order	3rd	5th	7th	11th	13th
Per-unit voltage	1.125	1.049	1.021	1.008	1.005

Once the harmonic study is completed and the filter selection has been made, the capacitor rating with respect to voltage, current, and kvar should be checked. All these three ratings need to be satisfied independently according to IEEE Std 18-1992 as noted earlier in 10.5.8. The filter designer could either satisfy these requirements himself if standard units are used, or request the capacitor supplier to meet these requirements if special units are used.

For industrial applications, either an air-core or iron-core reactor may be used depending upon the size and cost of the reactor. In general the iron-core reactors are limited to 13.8 kV. Air-core reactors are available for the complete range of low-voltage, medium-voltage, and high-voltage applications. The iron-cored reactors should save space and provide the advantage of being enclosed in indoor or outdoor housing along with capacitors and other control and protection components as required.

The reactors need to be rated for the maximum fundamental current and the “worst” generated harmonics for the “worst” system configuration. Also, the reactor vendor needs to calculate all the losses, fundamental and harmonic, core losses in case of the iron-cored reactors, and stray losses due to frequency effects so that the hot-spot temperatures are within the allowable dielectric temperature.

One big unknown factor during the filter design is the Q factor or the ratio of the inductive reactance to resistance at the tuned frequency. This is usually estimated based on experience. However, if during the study it is felt that Q is not critical, then the reactor should be specified to have the “natural Q ” (the Q of the reactor that is naturally obtained with no special design consideration or cost). On the other hand, if the low- Q reactor would help to mitigate amplifications near parallel resonance frequencies then a low- Q reactor should be specified. Manufacturers have a high tolerance on Q (as much as (20%)), and this should be recognized. Note also that the low Q design will produce higher losses.

10.8 Harmonic standards

In the United States, the Industry Application Society (IAS) of IEEE began a standards development project on harmonics in 1973. The first publication resulting from this project was IEEE Std 519-1981, entitled “IEEE Guide to Harmonic Control in Electrical Power Systems.” The IEEE publishes a hierarchy of Standards from the least to the most prescriptive, which are referred to as Guides, Recommended Practices, and Standards. In

1986, the Power Engineering Society (PES) joined the IAS to upgrade IEEE Std 519-1981 to the status of a Recommended Practice, and in 1992, IEEE Std 519-1992, entitled "IEEE Recommended Practices and Requirements for Harmonic Control in Electrical Power Systems," was published. Since then this document has acquired nearly the status of a Standard. It is widely used by the utilities and by industrial, commercial, and residential users in North and South America and around the world. It has become the basis for all new power system designs and for the interface between the utilities and their customers.

The key prescriptions of IEEE Std 519-1992 are provided in Chapter 10 (Recommended Practices for Individual Consumers) and in Chapter 11 (Recommended Practices for Utilities). These two chapters address the harmonic current distortion and harmonic voltage distortion, respectively, and with maintaining the power quality by both the supplier and the user. The document also provides limits for notching and IT values for converter applications.

IEEE Std 519-1992 primarily deals with odd harmonics; even harmonics are limited as a percentage of adjacent odd harmonics. It does not deal with the continuous spectrum of harmonics or interharmonics that may fall between the odd and even harmonics. Often, interharmonics are treated by engineers in the same manner as even harmonics. However, the subject of non-integer harmonics is being pursued by two task forces of the Working Group on Harmonics of the Power Engineering Society (Task Force on Application of the IEEE Standard 519 and Task Force on Interharmonics). It is expected that the publications of these task forces will highlight the application issues and interpretations of IEEE Std 519-1992 for different systems and users.

IEEE Std 519-1992 emphasizes the two following points in applying the harmonic indices: The point of interface or PCC between the supplier and the user, and the ratio of the system short-circuit (SC) MVA and the maximum demand load MVA. The PCC is a point mutually agreeable to the utility and the consumer and, in general, can be considered as the point of metering or any other point of interface. Within an industrial plant, the PCC is the point between the nonlinear load and other loads (IEEE Std 519-1992, 10.1). The SC ratio determines the total harmonic current distortion that can be injected into the system and allows higher limits for higher ratios. For current distortion limits, the fundamental current is calculated from the maximum demand load current, calculated over any 15 or 30 min period and then averaged over the preceding 12-month period (if the data are available). Note that the actual fundamental current at any particular time is likely to be less than the maximum demand fundamental current, so the latter helps to reduce the TDD percentage for any load less than the maximum demand load.

In conclusion, IEEE Std 519-1992 is a Recommended Practice and not a Standard. The limits should indeed be a matter of mutual agreement between the supplier and the utility. Further, strict compliance with IEEE Std 519-1992, within the industrial facility (as compared to the PCC) can require expenditure that may not be justifiable either technically or economically, and the effects of harmonics should be evaluated. It is expected that the future revision of IEEE Std 519-1992 will address the issue of limits for even harmonics and interharmonics more clearly. Also, it is expected that the future revision will clarify the application and interpretation of the document with several real-life examples.

10.9 References

IEEE Std 18-1992, IEEE Standard for Shunt Power Capacitors.³

IEEE Std 444-1973 (Reaff 1992), IEEE Standard Practices and Requirements for Thyristor Converters for Motor Drives, Part 1.

IEEE Std 519-1992, IEEE Recommended Practices and Requirements for Harmonic Control in Electrical Power Systems.

IEEE Std 597-1983 (Reaff 1992), IEEE Practices and Requirements for General Purpose Thyristor DC Drives.

IEEE Std C37.99-1990 (Reaff 1994), IEEE Guide for Protection of Shunt Capacitor Banks.

IEEE Std C57.110-1986 (Reaff 1992), IEEE Recommended Practice for Establishing Transformer Capability When Supplying Nonsinusoidal Load Currents.

10.10 Bibliography

[B1] Adamson, C., and Hingorani, N. G., *High Voltage Direct Current Power Transmission*. London: Garraway, Ltd., 1960.

[B2] Arrillaga, J., Bradley, D., and Boger, P. S., *Power Systems Harmonics*. England: John Wiley & Sons, Ltd., 1985.

[B3] CIGRE Working Group 36-05 (Disturbing Loads) (1981), Harmonic characteristic parameters, method of study, estimating of existing values in network, *Electra* 77: 35–54.

[B4] Czarnecki, L. S., and Tan, O. T., “Evaluation and reduction of harmonic distortion caused by solid state voltage controllers of induction motors,” *IEEE Transactions on Energy Conversion*, Vol. EC-9, No. 3, pp. 528–534, Sept. 1994.

[B5] Day, A. L., and Mahmoud, A. A., “Methods of evaluation of harmonic levels in industrial plant distribution systems,” *IEEE Transactions on Industry Applications*, Vol. IA-23, No. 3, pp. 498–503, May/June 1987.

[B6] Domijan, Jr., A., and Embriz-Santander, E., “A summary and evaluation of recent developments on harmonic mitigation techniques useful to adjustable speed drives,” *IEEE Transactions on Energy Conversion*, Vol. EC-7, No. 1, pp. 64–71, Mar. 1992.

³IEEE publications are available from the Institute of Electrical and Electronics Engineers, 445 Hoes Lane, P.O. Box 1331, Piscataway, NJ 08855-1331, USA.

[B7] Domijan, A., and Zaninelli, D., "IEC and IEEE standards on harmonics and comparisons," *Proceedings of National Science Foundation Conference on Unbundled Power Quality Services in the Power Industry*, Nov. 17–19, 1996, Key West, Florida.

[B8] Dugan, R. C., McGranahan, F. M., and Beaty, H. W., *Electrical Power Systems Quality*. New York: McGraw-Hill, 1996.

[B9] Emanuel, A. E., Orr, J. A., Cyganski, D., and Gulachenski, E. M., "A survey of harmonic voltages and currents at the customer's bus," *IEEE Transactions on Power Delivery*, Vol. PWRD-8, No. 1, pp. 411–421, Jan. 1993.

[B10] Etezadi-Amoli, M., and Florence, T., "Voltage and current harmonic content of a utility system—A summary of 1120 test measurements," *IEEE Transactions on Power Delivery*, Vol. PWRD-5, No. 3, pp. 1552–1557, July 1990.

[B11] Fujita, H., and Akagi, H., "A practical approach to harmonic compensation in power systems—Series connection of passive and active filters," *IEEE Transactions on Industry Applications*, Vol. IA-27, No. 6, pp. 1020–1025, Nov./Dec. 1991.

[B12] Gluskin, E., "High harmonic currents in fluorescent lamp circuits," *IEEE Transactions on Industry Applications*, Vol. IA-26, No. 2, pp. 347–351, Mar./Apr. 1990.

[B13] Gonzalez, D. A., and McCall, J. C., "Design of filters to reduce harmonic distortion in industrial power systems," *IEEE Transactions on Industry Applications*, Vol. IA, No. 3, pp. 504–511, May/June 1987.

[B14] Grotzbach, M., and Redman, R., "Analytical predetermination of complex line current harmonics in controlled AC/DC converter," *IEEE Conference Record*, IEEE/Industry Applications Society Annual Meeting, Orlando, p. 2165, Oct. 1995.

[B15] Hanna, R. A., "Harmonics and technical barriers in adjustable speed drives," *IEEE Transactions on Industry Applications*, Vol. IA-25, No. 5, pp. 894–900, Sept./Oct. 1989.

[B16] Henderson, R. D., and Rose, P. J., "Harmonics: The effects on power quality and transformers," *IEEE Transactions on Industry Applications*, Vol. IA-30, No. 3, pp. 528–532, May/June 1994.

[B17] Heydt, G.T., *Electric Power Quality*. Scottsdale, AZ: Stars in a Circle Publications, 1995.

[B18] Heydt, G. T., Kish, D. J., Holcomb, F., and Hill, Y., "A methodology for assessment of harmonic impact," *IEEE Transactions on Power Delivery*, Vol. PWRD-6, No. 4, pp. 1748–1754, Oct. 1991.

[B19] IEEE Power Engineering Society, IEEE Publication No. 84EH0221-2-PWR, Tutorial course: "Power system harmonics," 1984.

- [B20] IEEE Power Engineering Society, IEEE Publication No. 84TH0115-6 DWR, "Sine-wave distortion in power systems and the impact on protective relaying," 1984.
- [B21] IEEE Task Force Report, "Effects of Harmonics on Equipment," *IEEE Transactions on Power Delivery*, Vol. PWRD-8, No. 2, pp. 672–680, Apr. 1993.
- [B22] IEEE Task Force on Harmonics Modeling and Simulation, "Modeling and simulation of the propagation of harmonics in electrical power networks," Parts 1 & 2, *IEEE Transactions on Power Delivery*, Vol. PWRD-11, No. 1, pp. 452–474, Jan. 1996.
- [B23] Kimbark, E., *Direct Current Transmission*, New York: John Wiley & Sons, Inc., 1971.
- [B24] Lemieux, G., "Power system harmonic resonance—A documented case," *IEEE Transactions on Industry Applications*, Vol. IA-26, No. 3, pp. 483–488, May/June 1990.
- [B25] Lowenstein, M. Z., "Improving power factor in the presence of harmonics using low-voltage tuned filters," *IEEE Transactions on Industry Applications*, Vol. IA-29, No. 3, pp. 528–535, May/June 1993.
- [B26] Ludbrook, A., "Harmonic filters for notch reduction," *IEEE Transactions on Industry Applications*, Vol. IA-24, No. 5, Sept./Oct. 1988.
- [B27] Mahmoud, A. A., and Shultz, R.D., "A method for analyzing harmonic distribution in ac power systems," *IEEE Transactions on Power Apparatus and Systems*, Vol. PAS-101, No. 6, pp. 1815–1824, June 1982.
- [B28] Paice, D. A., *Power Electronic Converter Harmonics*. New York: IEEE Press, 1996.
- [B29] Phipps, J. K., Nelson, J. P., and Sen, P. K., "Power quality and harmonic distortion on distribution systems," *IEEE Transactions on Industry Applications*, Vol. IA-30, No. 2, pp. 476–484, Mar./Apr. 1994.
- [B30] Prabhakara, F. S., Smith, R. L., and Stratford, R. P., *Industrial and Commercial Power Systems Handbook*, New York: McGraw-Hill, 1995.
- [B31] Purkayastha, I., and Savoie, P. J., "Effect of harmonics on power measurement," *IEEE Transactions on Industry Applications*, Vol. IA-26, No. 5, pp. 944–946, Sept./Oct. 1990.
- [B32] Rastogi, M., Naik, R., and Mohan, N., "A comparative evaluation of harmonic reduction techniques in three-phase utility interface of power electronic loads," *IEEE Transactions on Industry Applications*, Vol. IA-30, No. 5, pp. 1149–1155, Sept./Oct. 1994.
- [B33] Redl, R., Tenti, P., and Van Wyk, J. D., "Power electronics' polluting effects," *IEEE Spectrum*, pp. 32–39, May 1997.
- [B34] Rice, D. E., "Adjustable speed drive and power rectifier harmonics—Their effect on power system components," *IEEE Transactions on Industry Applications*, Jan./Feb. 1986.

[B35] Schieman, R. G., and Schmidt, W. C., "Power line pollution by 3-phase thyristor motor drives," *IEEE/Industry Application Society Conference*, 1976 Annual Meeting.

[B36] Sen, P. K., and Landa, H. A., "Derating of induction motors due to waveform distortion," *IEEE Transactions on Industry Applications*, Vol. IA-26, No. 6, pp. 1102–1107, Nov./Dec. 1990.

[B37] Sharma, V., Fleming, R. J., and Niekamp, L., "An iterative approach for analysis of harmonic penetration in the power transmission networks," *IEEE Transactions on Power Delivery*, Vol. PWRD-6, No. 4, pp. 1689–1706, Oct. 1991.

[B38] Shipp, D. D., "Harmonic analysis and suppression for electrical systems supplying static power converters and other nonlinear loads," *IEEE Transactions on Industry Applications*. Sept./Oct. 1979.

[B39] Shuter, T. C., Volkommer, Jr., H. T., and Kirkpatrick, T. L., "Survey of harmonic levels on the American electric power distribution system," *IEEE Transactions on Power Delivery*, Vol. PWRD-4, No. 4, pp. 2204–2213, Oct. 1989.

[B40] Subjak, Jr., J., and McQuilkin, J., "Harmonics—Causes, effects, measurements, and analysis—Update," *IEEE/Industry Application Society Cement Industry Technical Conference*, May 1989.

[B41] Valcarcel, M., and Mayordomo, J. G., "Harmonic power flow for unbalanced systems," *IEEE Transactions on Power Delivery*, Vol. PWRD-8, No. 4, pp. 2052–2059, Oct. 1993.

[B42] Williams, S. M., Brownfield, G. T., and Duffus, J. W., "Harmonic propagation on an electric distribution system: Field measurements compared with computer simulation," *IEEE Transactions on Power Delivery*, Vol. PWRD-8, No. 2, pp. 547–552, Apr. 1993.

[B43] Yan, Y. H., Chen, C. S., Moo, C. S., and Hsu, C. T., "Harmonic analysis for industrial customers," *IEEE Transactions on Industrial Applications*, Vol. IA-30, No. 2, pp. 462–468, Mar./Apr. 1994.

Chapter 11

Switching transient studies

11.1 Power system switching transients

11.1.1 Introduction

An electrical transient occurs on a power system each time an abrupt circuit change occurs. This circuit change is usually the result of a normal switching operation, such as breaker opening or closing or simply turning a light switch on or off. Bus transfer switching operations along with abnormal conditions, such as inception and clearing of system faults, also cause transients.

The phenomena involved in power system transients can be classified into two major categories:

- a) Interaction between magnetic and electrostatic energy stored in the inductance and capacitance of the circuit, respectively,
- b) Interaction between the mechanical energy stored in rotating machines and electrical energy stored in the inductance and capacitance of the circuit.

Unlike the first category, which consists solely of electromagnetic transients, the latter deals with electromechanical transients and will not be treated in this chapter. Electromechanical transients are considered in Chapters 7 and 8.

Most power system transients are oscillatory in nature and are characterized by their transient period of oscillation. Despite the fact that these transient periods are usually very short when compared with the power frequency of 50 Hz or 60 Hz, they are extremely important because at such times, the circuit components and electrical equipment are subjected to the greatest stresses resulting from abnormal transient voltages and currents. While overvoltages may result in flashovers or insulation breakdown, overcurrent may damage power equipment due to electromagnetic forces and excessive heat generation. Flashovers usually cause temporary power outages due to tripping of the protective devices, but insulation breakdown usually leads to permanent equipment damage.

For this reason, a clear understanding of the circuit during transient periods is essential in the formulation of steps required to minimize and prevent the damaging effects of switching transients.

11.1.2 Circuit elements

All circuit elements, whether in utility systems, industrial plants, or commercial buildings, possess resistance, R , inductance, L , and capacitance, C . Ohm's law defines the voltage

across a time-invariant linear resistor as the product of the current flowing through the resistor and its ohmic value. That is,

$$v(t) = Ri(t) \quad (11-1)$$

The other two elements, L and C , are characterized by their ability to store energy. The term “inductance” refers to the property of an element to store electromagnetic energy in the magnetic field. This energy storage is accomplished by establishing a magnetic flux within the ferromagnetic material. For a linear time-invariant inductor, the magnetic flux is defined as the product of the inductance and the terminal current. Thus,

$$\phi(t) = Li(t) \quad (11-2)$$

where $\phi(t)$ is the magnetic flux in webers (Wb), L is the inductance in henries (H), and $i(t)$ is the time-varying current in amperes (A). By Faraday’s law, the voltage at the terminals of the inductor is the time derivative of the flux, namely,

$$v(t) = \frac{d\phi}{dt} \quad (11-3)$$

Combining this relationship with Equation (11-2) gives the voltage-current relation of a time-invariant linear inductor as

$$v(t) = L \frac{di}{dt} \quad (11-4)$$

Finally, the term “capacitance” means the property of an element that stores electrostatic energy. In a typical capacitance element, energy storage takes place by accumulating charges between two surfaces that are separated by an insulating material. The stored charge in a linear capacitor is related to the terminal voltage by

$$q(t) = Cv(t) \quad (11-5)$$

where C is the capacitance in farads (F) when the units of q and v are in coulombs (C) and volts (V), respectively. Since the electrical current flowing through a particular point in a circuit is the time derivative of the electrical charge, Equation (11-5) can be differentiated with respect to time to yield a relationship between the terminal current and the terminal voltage. Thus,

$$i(t) = \frac{dq}{dt} \quad \text{or} \quad i(t) = C \frac{dv}{dt} \quad (11-6)$$

Under steady-state conditions, the energy stored in the elements swings between the inductance and capacitance in the circuit at the power frequency. When there is a sudden change in the circuit, such as a switching event, a redistribution of energy takes place to accommodate the new condition. This redistribution of energy cannot occur instantaneously for the following reasons:

- a) The electromagnetic energy stored in an inductor is $E = \frac{LI^2}{2}$. For a constant inductance, a change in the magnetic energy requires a change in current. But the change in current in an inductor is opposed by an emf of magnitude $v(t) = L \frac{di}{dt}$. For the current to change instantaneously ($dt = 0$), an infinite voltage is required. Since this is unrealizable in practice, the change in energy in an inductor requires a finite time period.
- b) The electrostatic energy stored in a capacitor is given by $E = \frac{CV^2}{2}$ and the current-voltage relationship is given by $i(t) = C \frac{dv}{dt}$. For a capacitor, an instantaneous change in voltage ($dt = 0$) requires an infinite current, which cannot be achieved in practice. Therefore, the change in voltage in a capacitor also requires finite time.

These two basic concepts, plus the recognition that the rate of energy produced must be equal to the sum of the rate of energy dissipated and the rate of energy stored at all times (principle of energy conservation) are basic to the understanding and analysis of transients in power systems.

11.1.3 Analytical techniques

The classical method of treating transients consists of setting up and solving the differential equation or equations, which must satisfy the system conditions at every instant of time. The equations describing the response of such systems can be formulated as linear time-invariant differential equations with constant coefficients. The solution of these equations consists of two parts:

- a) The homogeneous solution, which describes the transient response of the system, and
- b) The particular solution, which describes the steady-state response of the system to the forcing function or stimulus.

As discussed and described in Chapter 3, the analytical solution of linear differential equations can also be obtained by the Laplace transform method. This technique does not require the evaluation of the constants of integration and is a powerful tool for complex circuits, where the traditional method can be quite difficult.

11.1.4 Transient analysis based on the Laplace transform method

Although they do not represent the types of problems regularly encountered in power systems, the transient analysis of the simple RL and RC circuits described in Chapter 3 of this book are useful illustrative examples of how the Laplace transform method can be used for solving circuit transient problems. Real-life circuits, however, are far more complicated and often retain many circuit elements in series-parallel combination even after simplification. These circuits will require several differential or integro-differential equations to describe transient behavior and must be solved simultaneously to evaluate the response. To do this efficiently, the Laplace transform method is often used.

11.1.4.1 LC transients

In this chapter, the more general types of circuits that are described by higher-order differential equations are discussed. The double-energy transient, or *LC* circuit, is the first type of circuit to be considered. In double-energy electric circuits, energy storage takes place in the magnetic field of inductors and in the electric field of the capacitors. In real circuits, the interchange of these two forms of energy may, under certain conditions, produce electric oscillations. The theory of these oscillations is of great importance in electric power systems.

In the circuit shown in Figure 11-1 the circuit elements are represented with Laplace transform impedances as described in Chapter 3. The response of the circuit to a step input of voltage due to the closing of the switch at $t = 0$ will be examined, assuming the capacitor is initially charged to the potential of $V_c(0^-)$ as shown.

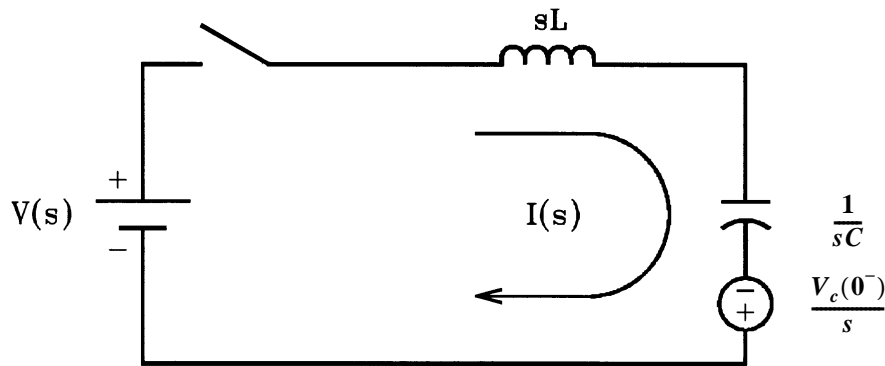

Figure 11-1—Double energy network

According to Kirchoff's voltage law, the sum of the voltages across all the circuit elements must equal the source voltage at all times. In equation form this is stated as

$$V(s) = I(s)s^2L - sLI(0) + \frac{I(s)}{C} - V_c(0) \quad (11-7)$$

Since there could be no current flowing in the circuit before the switch closes, the term $LI(0) = 0$. Solving for the current $I(s)$ in Equation (11-7),

$$I(s) = \frac{V(s) + V_c(0)}{L} \left[\frac{1}{(s^2 + \omega_0^2)} \right] \quad (11-8)$$

where ω_0^2 is the natural frequency of the circuit, namely $\frac{1}{\sqrt{LC}}$. From the table of inverse Laplace transforms (see table in Chapter 3), the transient response in the time domain is

$$i(t) = \frac{V(s) + V_c(0)}{Z_0} [\sin(\omega_0 t)] \quad (11-9)$$

where Z_0 is the surge impedance of the circuit defined by

$$Z_0 = \sqrt{\frac{L}{C}} \quad (11-10)$$

Clearly, the transient response indicates a sinusoidal current with a frequency governed by the circuit parameters L and C only.

Another interesting feature about the time response of the current in the circuit is that the magnitude of the current is inversely proportional to the surge impedance of the circuit Z_0 , which is a function of the circuit parameters of L and C . The importance of this parameter to the analysis of transient problems will be demonstrated later in the chapter.

In power system analysis, we are often interested in the voltage across the capacitor. Referring to Figure 11-1, the capacitor voltage is

$$V_c(s) = \frac{I(s)}{sC} - \frac{V_c(0)}{s} \quad (11-11)$$

where $V_c(0)$ is the initial voltage of the capacitor. Solving for $I(s)$ in the above equation results in

$$I(s) = sCV_c(s) + CV_c(0) \quad (11-12)$$

But because the current $I(s)$ is common to both elements L and C , we can substitute Equation (11-12) into Equation (11-8) to obtain the voltage across the capacitor. After rearranging the terms,

$$V_c(s) = \frac{V(s)\omega_0^2}{s(s^2 + \omega_0^2)} + \frac{sV_c(0)}{(s^2 + \omega_0^2)} \quad (11-13)$$

From the table of inverse Laplace transforms (see Chapter 3), the transient response is

$$v_c(t) = V(s)[1 - \cos(\omega_0 t)] + V_c(0)\cos(\omega_0 t) \quad (11-14)$$

The above equation is plotted in Figure 11-2 for various values of initial capacitor voltage $V_c(0)$.

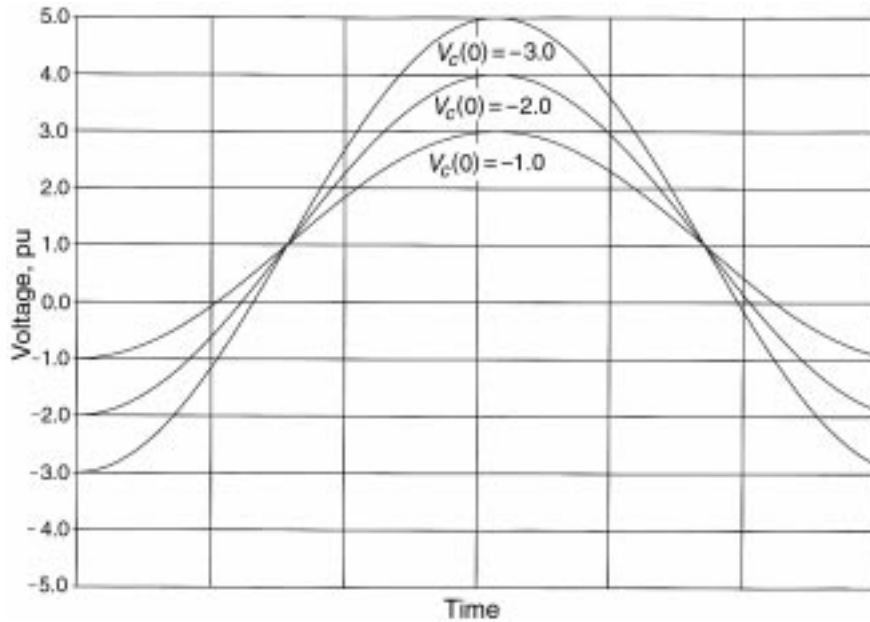

Figure 11-2—Capacitor voltage for various initial voltages

Examination of these curves indicates that, without damping, the capacitor voltage swings as far above the source voltage V as it starts below. In a real circuit, however, this will not be the case, since circuit resistance will introduce losses and will damp the oscillations. Treatment of the effects of resistance in the analysis of circuits is presented next.

11.1.4.2 Damping

Nearly every practical electrical component has resistive losses (I^2R losses). To simplify the calculations and to ensure more conservative results, resistive losses are usually neglected as a first attempt to a switching transient problem. Once the behavior of the circuit is understood, then system losses can be considered if deemed necessary.

A parallel RLC circuit is depicted in Figure 11-3, in which the circuit elements are represented by their Laplace transform admittances. Many practical transient problems found in power systems can be reduced to this simple form and still yield acceptable results. With a constant current source, $I(s)$ and zero initial conditions, the equation describing the current in the parallel branches is

$$I(s) = sV(s)G + s^2CV(s) + \frac{V(s)}{L} \quad (11-15)$$

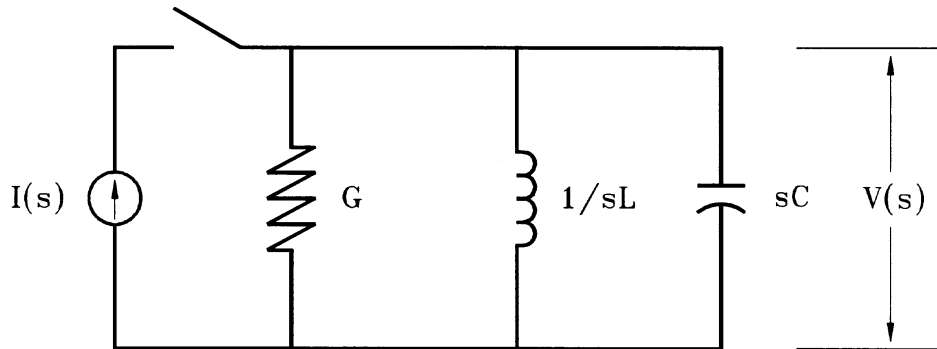

Figure 11-3—Parallel *RLC* circuit

Solving for the voltage results in

$$V(s) = \frac{I(s)}{C} \left(\frac{1}{s^2 + \frac{s}{RC} + \frac{1}{LC}} \right) \quad (11-16)$$

Equation (11-16) can be written as

$$V(s) = \frac{I(s)}{C} \left[\frac{1}{(s + r_1)(s + r_2)} \right] \quad (11-17)$$

where r_1 and r_2 are the roots of the characteristic equation defined as follows:

$$r_1 = \frac{1}{2RC} + \frac{1}{2} \sqrt{\left(\frac{1}{RC}\right)^2 - \left(\frac{4}{LC}\right)} \quad \text{and} \quad r_2 = \frac{1}{2RC} - \frac{1}{2} \sqrt{\left(\frac{1}{RC}\right)^2 - \left(\frac{4}{LC}\right)} \quad (11-18)$$

At the natural resonant frequency ω_0 , the reactive power in the inductor is equal to the power in the capacitor but opposite in sign. The source has to supply only the true power P_T required by the resistance in the circuit. The ratio between the magnitude of the reactive power, P_R , of either the inductance or the capacitance at the resonant frequency, and the magnitude of true power, P_T of the circuit, is known as the quality factor of the circuit, or Q . Therefore, for the parallel circuit,

$$Q_P = \frac{P_R}{P_T} \quad \text{or} \quad Q_P = \frac{V^2 B}{V^2 G} \quad \text{or} \quad Q_P = \frac{R}{X} \quad (11-19)$$

where B is the susceptance of either the inductor or capacitor, G is the conductance, and V is the voltage across the element. But, since in a parallel circuit the voltage is common to all elements, substituting $\omega_0 L$ for $\frac{1}{B}$ and R for $\frac{1}{G}$ in Equation (11-19), the result is

$$Q_P = \frac{R}{\omega_0 L} \quad (11-20)$$

Furthermore, since the natural frequency of the circuit is

$$\omega_0 = \frac{1}{\sqrt{LC}} \quad (11-21)$$

then, substituting Equation (11-21) into Equation (11-20) yields

$$Q_P = \frac{R}{\sqrt{\frac{L}{C}}} \quad (11-22)$$

Rearranging Equation (11-18), we have

$$r_1 = \frac{1}{2RC} + \frac{1}{2RC} \sqrt{1 - 4R^2 \frac{C}{L}} \quad \text{and} \quad r_2 = \frac{1}{2RC} - \frac{1}{2RC} \sqrt{1 - 4R^2 \frac{C}{L}} \quad (11-23)$$

Substituting Equation (11-22) into Equation (11-23), the result is

$$r_1 = \frac{1}{2RC} + \frac{1}{2RC} \sqrt{1 - 4Q_P^2} \quad \text{and} \quad r_2 = \frac{1}{2RC} - \frac{1}{2RC} \sqrt{1 - 4Q_P^2} \quad (11-24)$$

Depending on the values of the circuit parameters, the quantity under the radical in Equation (11-24) may be positive, zero, or negative.

For positive values, that is $4Q_P^2 < 1$, the roots are real, negative, and unequal. In this case, the inverse Laplace transform of Equation (11-17) is

$$v(t) = \frac{I R e^{-\left(\frac{t}{2RC}\right)}}{\sqrt{1 - 4Q_P^2}} [e^{\omega_D t} - e^{-\omega_D t}] \quad (11-25)$$

where

$$\omega_D = \frac{\sqrt{1 - 4Q_P^2}}{2RC} \quad (11-26)$$

is the damped natural angular frequency. Substituting $2\sinh(\omega_D t)$ for the exponential function, the result is

$$v(t) = \frac{2IRe^{-\left(\frac{t}{2RC}\right)}}{\sqrt{1-4Q_P^2}} \left[\sinh\left(\frac{\sqrt{1-4Q_P^2}}{2RC} t\right) \right] \quad (11-27)$$

For the case where the quantity $4Q_P^2 = 1$, the roots are equal, negative, and real. Therefore, the solution of Equation (11-25) is

$$v(t) = \frac{I}{C} e^{-\left(\frac{t}{2RC}\right)} \quad (11-28)$$

Finally, when the quantity under the radical sign in Equation (11-4) is less than zero, that is, $4Q_P^2 > 1$, the roots are unequal and complex. The solution in this case is

$$v(t) = \frac{2IRe^{-\left(\frac{t}{2RC}\right)}}{\sqrt{4Q_P^2-1}} \left[\sin\left(\frac{\sqrt{4Q_P^2-1}}{2RC} t\right) \right] \quad (11-29)$$

Consider the series *RLC* circuit shown in Figure 11-4.

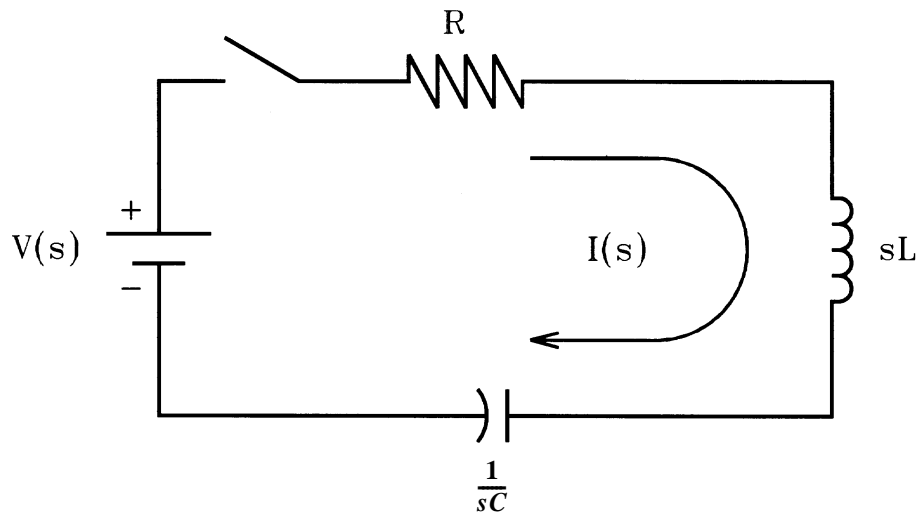

Figure 11-4—Series *RLC* circuit

With $V(s)$ as a constant source, the equation describing the current in the circuit is

$$I(s) = \frac{V(s)}{s} \left(\frac{1}{R + sL + \frac{1}{sC}} \right) \quad (11-30)$$

Rearranging the terms results in

$$I(s) = \frac{V(s)}{L} \left(\frac{1}{s^2 + s\frac{R}{L} + \frac{1}{LC}} \right) \quad (11-31)$$

The expression inside the brackets is similar to the expression for the parallel RLC circuit shown in Equation (11-16). The only difference is the coefficient of s . Rewriting, as in Equation (11-17) gives

$$I(s) = \frac{V(s)}{L} \left[\frac{1}{(s + r_1)(s + r_2)} \right] \quad (11-32)$$

where r_1 and r_2 are the roots of the characteristic equation defined as

$$r_1 = \frac{R}{2L} + \frac{R}{2L} \sqrt{\left(1 - \frac{4L}{R^2C}\right)} \quad \text{and} \quad r_2 = \frac{R}{2L} - \frac{R}{2L} \sqrt{\left(1 - \frac{4L}{R^2C}\right)} \quad (11-33)$$

Again, we define the quality factor of the series RLC circuit, Q_s , as the ratio of the magnitude of the reactive power of either the inductor or the capacitor at the resonant frequency to the magnitude of the true power in the circuit. Stated in equation form, results in

$$Q_s = \frac{P_R}{P_T} \quad (11-34)$$

With the reactive power $P_R = I^2X$ and the true power as $P_T = I^2R$, then

$$Q_s = \frac{I^2X}{I^2R} \quad (11-35)$$

But since, in a series circuit, the current is common to all elements, then

$$Q_s = \frac{\omega_0 L}{R} \quad (11-36)$$

where $\omega_0 L = X$. Also, since $\omega_0 = \frac{1}{\sqrt{LC}}$, then Equation (11-36) can be written as

$$Q_s = \frac{\sqrt{L}}{R} \quad \text{or} \quad Q_s = \frac{Z_0}{R} \quad (11-37)$$

Note that the above expression is the ratio of the surge impedance to the resistance in the circuit. This is the reciprocal of the expression developed for the parallel RLC circuit and described by Equation (11-22). That is,

$$Q_s = \frac{1}{Q_p} \quad (11-38)$$

Substituting Equation (11-37) into Equation (11-33) results in

$$r_1 = \frac{R}{2L} + \frac{R}{2L} \sqrt{1 - 4Q_s^2} \quad \text{and} \quad r_2 = \frac{R}{2L} - \frac{R}{2L} \sqrt{1 - 4Q_s^2} \quad (11-39)$$

Above expressions have already been solved for the parallel RLC circuit. To obtain the expression as a function of time, simply substitute Q_s for Q_p and V/R for $I R$ and R/L for $1/RC$ in Equation (11-26) and Equation (11-28) and V/L for I/C and R/L for $1/RC$ in Equation (11-29). Thus, when the quantity under the radical sign is less than 1, namely, $4Q_s^2 < 1$, the result is

$$i(t) = \frac{2V e^{-\left(\frac{Rt}{2L}\right)}}{R \sqrt{1 - 4Q_s^2}} \left[\sinh \left(\frac{R}{2L} \sqrt{1 - 4Q_s^2} \right) \right] \quad (11-40)$$

For the case where the quantity $4Q_s^2 = 1$, then the roots are equal, negative, and real and the solution of Equation (11-39) is

$$i(t) = \frac{V}{L} e^{-\left(\frac{Rt}{2L}\right)} \quad (11-41)$$

Finally, when the quantity $4Q_s^2 > 1$, the roots are complex and unequal. Therefore, the solution is

$$i(t) = \frac{2V e^{-\left(\frac{Rt}{2L}\right)}}{R \sqrt{4Q_s^2 - 1}} \left[\sin \left(\frac{R}{2L} \sqrt{4Q_s^2 - 1} \right) \right] \quad (11-42)$$

11.1.5 Normalized damping curves

The response of the parallel and series *RLC* circuits to a step input of current or voltage, respectively, can be expressed as a family of normalized damping curves, which can be used to estimate the response of simple switching transient circuits to a step input of either voltage or current. To develop a family of normalized damping curves, proceed as follows:

- a) To per-unitize the solutions, we use the undamped response of a parallel *LC* circuit as the starting point. Thus, for the voltage,

$$v(t) = \frac{1}{\omega_0 C} \sin(\omega_0 t) \quad (11-43)$$

and, for the current,

$$i(t) = \frac{1}{\omega_0 L} \sin(\omega_0 t) \quad (11-44)$$

The maximum voltage or current occurs when the angular displacement $\omega_0 t = \pi/2$. Thus,

$$v(t) = \frac{1}{\omega_0 C} \quad \text{and} \quad i(t) = \frac{1}{\omega_0 L} \quad (11-45)$$

- b) Setting the angular displacement $\omega_0 t = \theta$, the quantity $\frac{t}{2RC}$ in Equations (11-26) through (11-28) can be substituted with the expression $\frac{\theta}{2Q_P}$.
- c) Finally, dividing Equations (11-26) through (11-28) by the right side of the expression for $v(t)$ in Equation (11-45) produces a set of normalized curves for the voltage on the parallel *RLC* circuit as a function of the dimensionless quantities Q_P and the displacement θ .

Thus, for $4Q_P^2 < 1$,

$$f(Q_P, \theta) = \frac{2Q_P e^{-\left(\frac{\theta}{2Q_P}\right)}}{\sqrt{1-4Q_P^2}} \left[\sinh\left(\frac{\theta \sqrt{1-4Q_P^2}}{2Q_P}\right) \right] \quad (11-46)$$

and, for $4Q_P^2 = 1$,

$$f(Q_P, \theta) = \theta e^{-\left(\frac{\theta}{2Q_P}\right)}, \quad (11-47)$$

and, for $4(Q_p^2 > 1)$, the result is

$$f(Q_p, \theta) = \frac{2Q_p e^{-\left(\frac{\theta}{2Q_p}\right)}}{\sqrt{4Q_p^2 - 1}} \left[\sin\left(\frac{\theta \sqrt{4Q_p^2 - 1}}{2Q_p}\right) \right] \quad (11-48)$$

Equations (11-46) through (11-48) are plotted in Figure 11-5 and Figure 11-6 for various values of Q_p . For series *RLC* circuits, divide the same equations in step c) by the right side of the expression for $i(t)$, and substitute Q_s for Q_p .

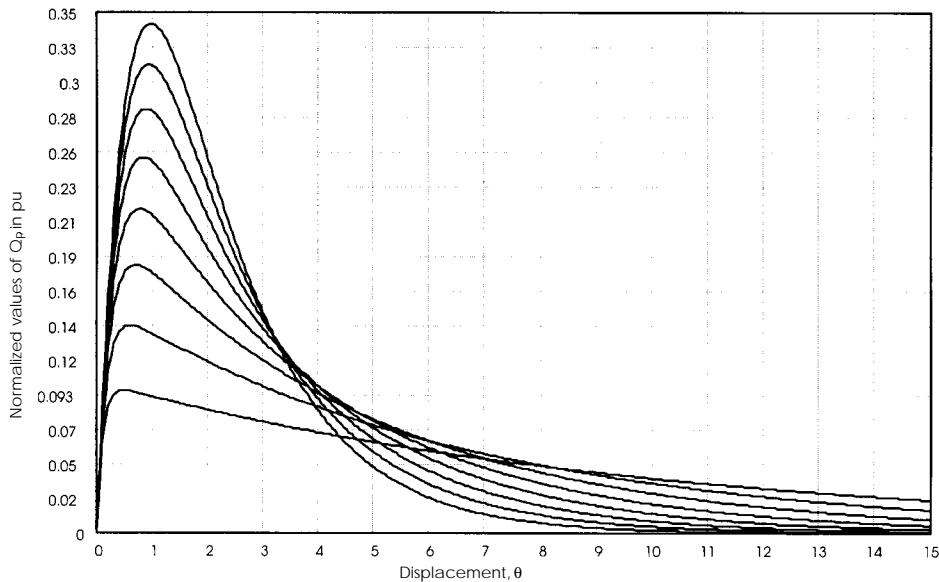
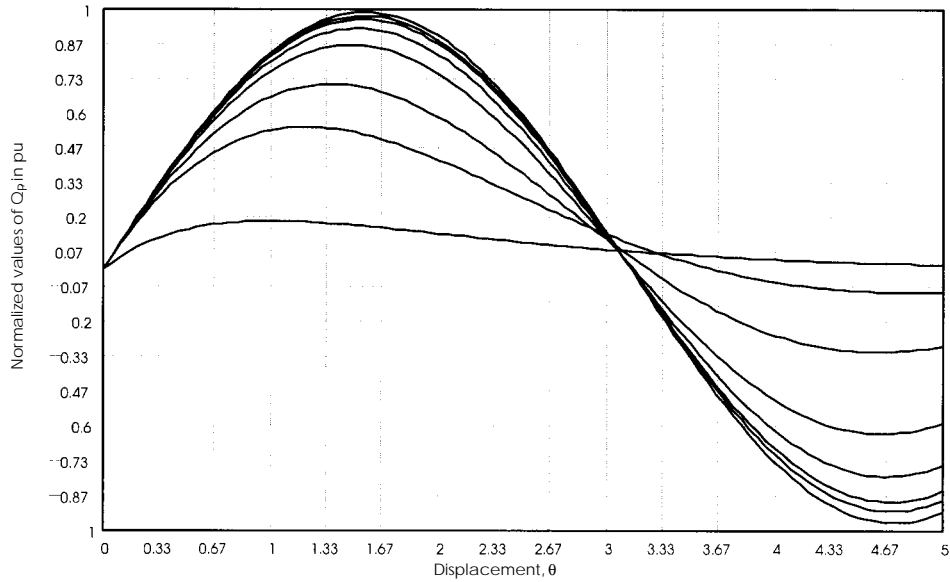

**Figure 11-5—Normalized damping curves, $0.10 \leq Q_p \leq 0.45$
in steps of 0.05, with $Q_p(0.45) = 0.34$ pu**

11.1.6 Transient example: Capacitor voltage

Very often, in power systems analysis, the form and magnitude of the transient voltage developed across the capacitor during switching is significant. To develop generalized expressions for capacitor voltage, start with Equation (11-31), which describes the transient current in the series *RLC* circuit. The voltage across the capacitor is simply the product of the current and the capacitor impedance, that is,

$$V_c(s) = I(s)Z_c(s) \quad (11-49)$$



**Figure 11-6—Normalized damping curves, $0.50 \leq Q_p \leq 75.0$
0.50, 1.0, 2.0, 5.0, 10.0, 15.0, 30.0, and 75.0, with $Q_p(75) = 1.00$ p.u.**

or

$$V_c(s) = \frac{I(s)}{sC} \quad (11-50)$$

Substituting Equation (11-30) into Equation (11-50), yields the expression for the voltage across the capacitor in a series *RLC* circuit. Thus,

$$V_c(s) = \frac{V(s)}{LC} \left[\frac{1}{s \left(s^2 + s \frac{R}{L} + \frac{1}{LC} \right)} \right] \quad (11-51)$$

Equation (11-51) is similar to the Equation (11-30), developed for the current, except that it has an extra *s* term in the denominator. The expression can be rewritten as follows:

$$V_c(s) = \frac{V(s)}{LC} \left[\frac{1}{s(s + r_1)(s + r_2)} \right] \quad (11-52)$$

where the roots of the equation are the same as those defined by Equation (11-39). Again, the solution of Equation (11-52) will depend on the values of Q_s .

Equation (11-14) shows the voltage across a capacitor due to a step input of voltage when the resistance in the circuit is zero. For zero initial conditions, that is, no charge in the capacitor,

the last term in Equation (11-14) can be neglected. Then, the maximum voltage occurs when $\omega_0 t = \pi$.

Therefore, the voltage is simply

$$V_c(t) = 2 \quad (11-53)$$

Following exactly the same procedures outlined in 11.1.5, Equation (11-51) has three possible solutions.

For the case in which $4(Q_s^2 < 1)$,

$$f(Q_s, \theta) = 1 - e^{-\left(\frac{\theta}{2Q_s}\right)} \left[\frac{\sinh\left(\frac{\theta\sqrt{1-4Q_s^2}}{2Q_s}\right)}{\sqrt{1-4Q_s^2}} + \cosh\left(\frac{\theta\sqrt{1-4Q_s^2}}{2Q_s}\right) \right] \quad (11-54)$$

When $4Q_s^2 = 1$, the solution is

$$f(Q_s, \theta) = 2Q_s \left[1 - e^{-\left(\frac{\theta}{2Q_s}\right)} \left(1 + \frac{\theta}{2Q_s} \right) \right] \quad (11-55)$$

Finally, when $4Q_s^2 > 1$, the solution takes the form of

$$f(Q_s, \theta) = 1 - e^{-\left(\frac{\theta}{2Q_s}\right)} \left[\frac{\sin\left(\frac{\theta\sqrt{4Q_s^2-1}}{2Q_s}\right)}{\sqrt{4Q_s^2-1}} + \cos\left(\frac{\theta\sqrt{4Q_s^2-1}}{2Q_s}\right) \right] \quad (11-56)$$

Equations (11-54) through (11-56) are plotted in Figure 11-7 for various values of Q_s .

11.1.7 Switching transient examples

In the previous subclauses, some simple circuits were examined that can be used to model many switching problems in electrical power systems. Very often, practical switching transient problems can be reduced to either parallel or series *RLC* circuits for the purpose of evaluating the response of the network to a particular stimuli on a first-trial basis. To gain familiarity with the normalized damping curves developed in the previous subclauses, some typical switching problems in power systems will be examined. Consider, for example, a

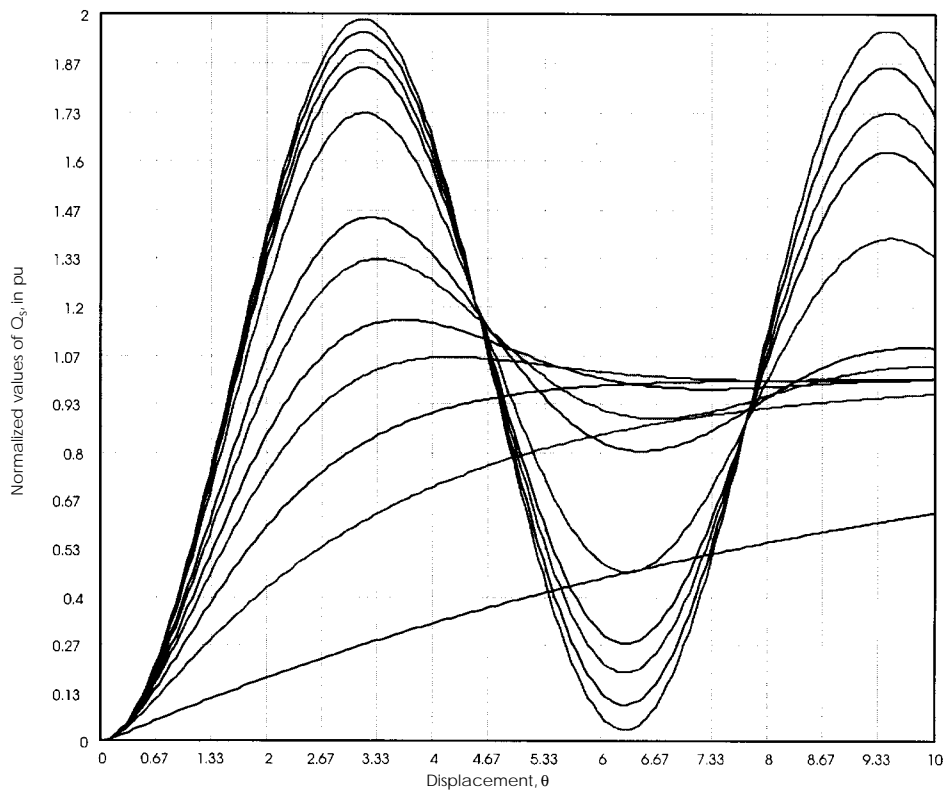

**Figure 11-7—Normalized damping curves, $0.10 \leq Q_s \leq 100$
0.10, 0.30, 0.50, 0.75, 1.0, 1.5, 2.0, 5.0, 10.0, 15.0, 30.0,
and 100.0 with $Q_s(100) = 1.99$**

1000 kVA unloaded transformer that, when excited from the 13.8 kV side with its rated voltage of 13.8 kV, draws a no-load current of 650 mA with a power factor of 10.4%. A test circuit for the transformer is shown in Figure 11-8. The battery voltage, V , and the resistance, R , are chosen such that, with the switch closed, the battery delivers 10 mA. For this example, a shunt capacitance of 2.8 nF per phase is assumed. The goal is to find the voltage across the capacitance to ground, when the switch is suddenly opened and the flow of current is interrupted.

From the information provided, the no-load current of the transformer is

$$I_{NL} = 0.067794 - j0.64644 \text{ A}$$

The magnetizing reactance X_M and inductance L_M per phase are, respectively,

$$X_M = \frac{13.8 \text{ kV}}{\sqrt{3} \times 0.64644} = 12.325 \text{ k}\Omega$$

$$L_M = \frac{X_M}{2\pi f} = \frac{12.325 \text{ k}\Omega}{377} = 32.693 \text{ H}$$

With a shunt capacitance of $C_{SH} = 2.8 \text{ nF}$, the shunt capacitive reactance is

$$X_{SH} = \frac{1}{2\pi f C_{SH}} = \frac{1}{377 \times 2.8 \text{ nF}} = 947.33 \text{ k}\Omega$$

Since $X_{SH} > X_M$, the effects of the shunt capacitive reactance at the power frequency are negligible. The resistance R_C is

$$R_C = \frac{13.8 \text{ kV}}{\sqrt{3} \times 0.067794} = 117.524 \text{ k}\Omega$$

Using delta-wye transformation impedance conversion, the circuit in Figure 11-8 can be redrawn as shown in Figure 11-9. In the Laplace transform notation, the equation describing the circuit at $t = 0^+$ is

$$0 = \frac{I_L(0^-)}{sL} + \frac{V_c(s)}{s} + sCV_c(s) - CV_c(0^-) + \frac{V_c(s)}{R}$$

where

$$L = \frac{3L_M}{2} = 49.035 \text{ H}$$

$$C = \frac{2C_{SH}}{3} = 1.867 \text{ nF}$$

$$R = \frac{3R_C}{2} = 176.286 \text{ k}\Omega$$

Assuming that dc steady-state was obtained before the switch opened, the term $CV_c(0^-) = 0$ and the initial current in the inductor at $t = 0^+$ is $I_L(0^-) = 10 \text{ mA}$. Solving for $V_c(s)$ and after rearranging the terms, gives

$$V_c(s) = -\frac{I_L(0^-)}{C} \left(\frac{1}{s^2 + \frac{s}{RC} + \frac{1}{LC}} \right)$$

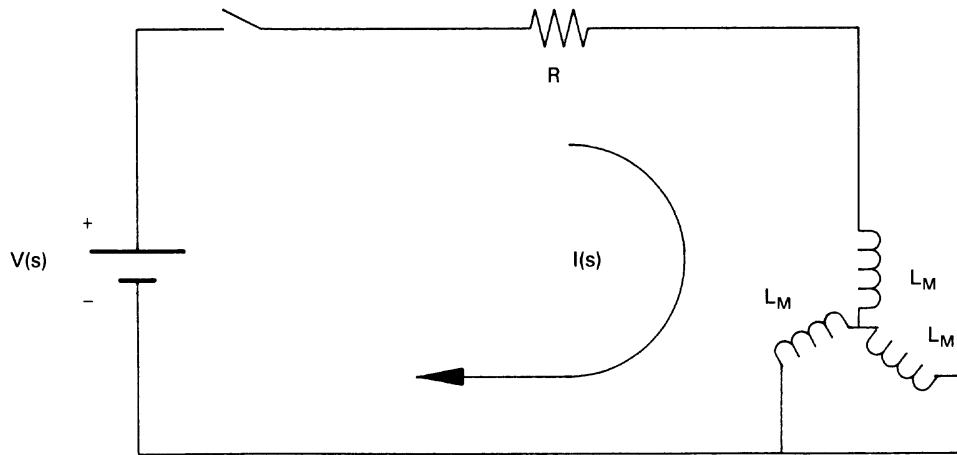

Figure 11-8—Test setup of unloaded transformer

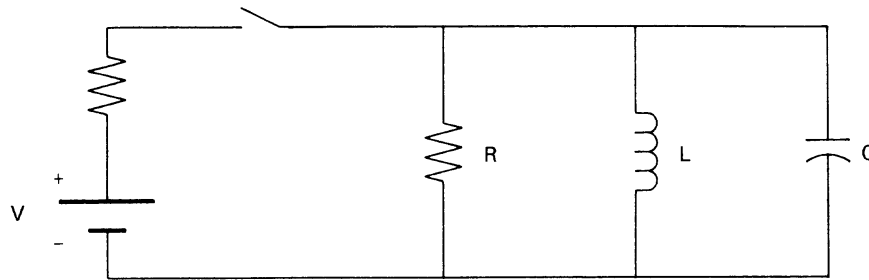

Figure 11-9—Equivalent *RLC* circuit for unloaded transformer

The time-response solution for this expression has already been obtained and, depending on the values of the circuit parameters, is shown in Equations (11-26), (11-27), and (11-28). The values for R , L , and C could be inserted into one of those equations to obtain the capacitor voltage for this problem. But this has also been done through the normalized damping curves shown in Figure 11-5. Therefore, the answers for this particular problem are obtained as follows:

- a) The surge impedance of the circuit is

$$Z_0 = \sqrt{\frac{L}{C}} = 162.07 \text{ k}\Omega$$

- b) Without damping, the peak transient voltage would be

$$V_{\text{peak}} = I(0^-) Z_0 = -10 \text{ mA} \times 162.076 \text{ k}\Omega = -1.621 \text{ kV}$$

- c) But since there is damping, the quality factor of the parallel circuit Q_P is

$$Q_P = \frac{R}{Z_0} = \frac{176.286 \text{ k}\Omega}{162.076 \text{ k}\Omega} = 1.087$$

- d) From the curves shown in Figure 11-5 and with $Q_P \approx 1.0$, the maximum per unit voltage is 0.57. Therefore, from step b), the maximum voltage developed across the capacitor is

$$V_{\text{max}} = -1.621 \text{ kV} \times 0.57 = -924 \text{ V}$$

- e) The maximum peak occurs at approximately $\theta = 1.2$ radians. Since $\omega_0 t = \theta$ and

$$\omega_0 = \frac{1}{\sqrt{LC}} \text{ or}$$

$$\omega_0 = 3305 \text{ rad/s}$$

Figure 11-10 depicts the actual voltage across the capacitance to ground as calculated by a computer program.

Another practical case will be examined, which concerns capacitor bank switching as depicted in Figure 11-11. Capacitor C_1 is rated 30 Mvar, three-phase, at 13.8 kV. C_2 is initially uncharged and is rated 10 Mvar, three-phase, also at 13.8 kV. The cable connecting capacitor C_2 to the bus has an inductance L of 35 μH . The following procedure is used to determine the magnitude of the inrush current and the size of the resistor required to limit this current to a maximum of 5800 A (peak) during energization.

From the problem statement, the capacitive reactance of the capacitors is

$$X_{c1} = \frac{\text{kV}^2}{C_1} = \frac{13.8^2}{30} = 6.348 \text{ }\Omega$$

$$X_{c2} = \frac{\text{kV}^2}{C_2} = \frac{13.8^2}{10} = 19.044 \text{ }\Omega$$

and the capacitance is

$$C_1 = \frac{1}{2\pi f X_{c1}} = \frac{1}{2\pi \times 60 \times 6.348 \text{ }\Omega} = 417.861 \text{ }\mu\text{F}$$

$$C_2 = 139.287 \text{ }\mu\text{F}$$

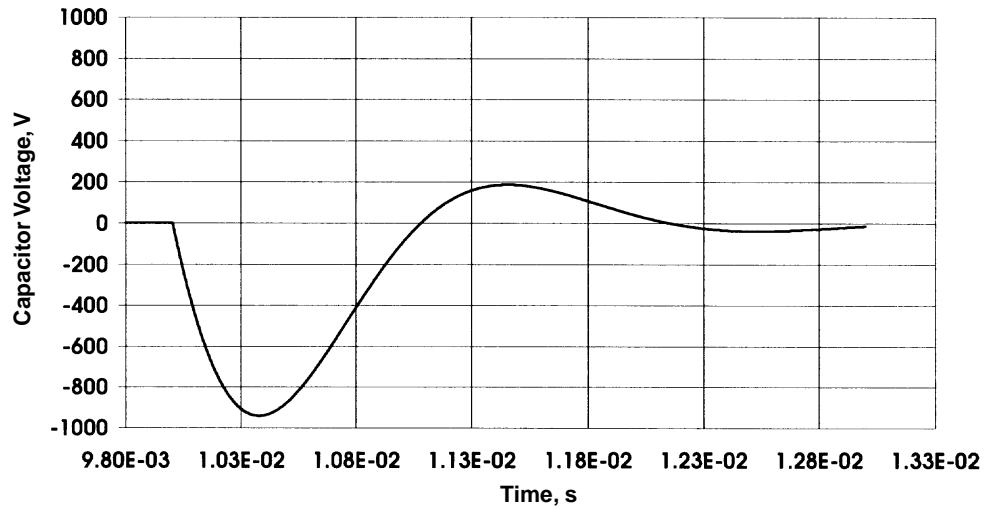

Figure 11-10—Actual capacitor voltage

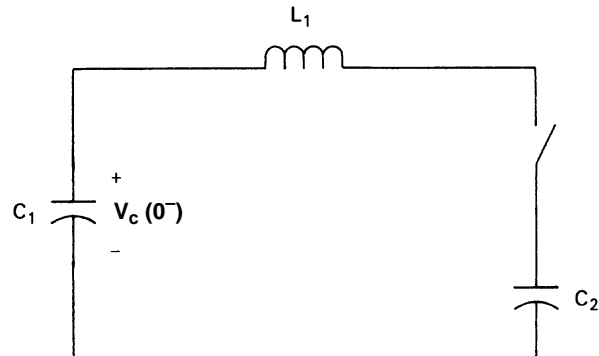

Figure 11-11—Capacitor bank switching

Assuming worst-case conditions, that is, C_1 charged to peak system voltage or

$$V_{c1} = \frac{\text{kV} \times \sqrt{2}}{\sqrt{3}} = \frac{13.8 \times \sqrt{2}}{\sqrt{3}} = 11.268 \text{ kV}$$

and with a surge impedance of

$$Z_0 = \sqrt{\frac{L(C_1 + C_2)}{C_1 C_2}} = 0.579 \text{ } \Omega$$

Then, with no damping, the inrush current would be

$$i_{\text{peak}} = \frac{V_{c(0)}}{Z_0} = \frac{11.268 \text{ kV}}{0.579 \Omega} = 19.467 \text{ kA}$$

Redrawing the circuit of Figure 11-11 to show the necessary addition of a resistor to limit the inrush current yields the circuit as shown in Figure 11-12.

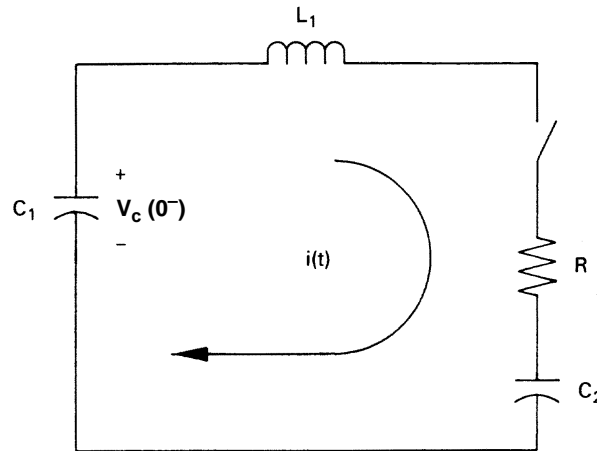

Figure 11-12—Equivalent circuit for capacitor switching with pre-insertion resistor

The problem requires that the inrush current should not exceed 5800 A. This represents a per-unit value of

$$I_{\text{pu}} = \frac{I_{\text{max}}}{I_{\text{peak}}} = \frac{5800 \text{ A}}{19467 \text{ A}} = 0.30$$

Referring to Figure 11-5, since the current problem concerns a series circuit, Q_s replaces Q_p . With a per-unit value requirement of 0.30 (vertical axis), Figure 11-5 shows that a $Q_p = 0.30$ will reduce the current to 5800 (19467×0.30) A or less. Now, since

$$Q_s = 0.30$$

and

$$Q_s = \frac{Z_0}{R} = 0.30$$

then

$$R = \frac{Z_0}{Q_s} = \frac{0.579 \Omega}{0.30} = 1.93 \Omega$$

Therefore, to limit the inrush current to 5800 A a 1.9 Ω resistor must be placed in series with capacitor C₂ as shown in Figure 11-12.

The results of a computer simulation are depicted in Figure 11-13 and Figure 11-14. While Figure 11-13 shows the current without the pre-insertion resistor, Figure 11-14 reflects the current with the 1.9 Ω resistor.

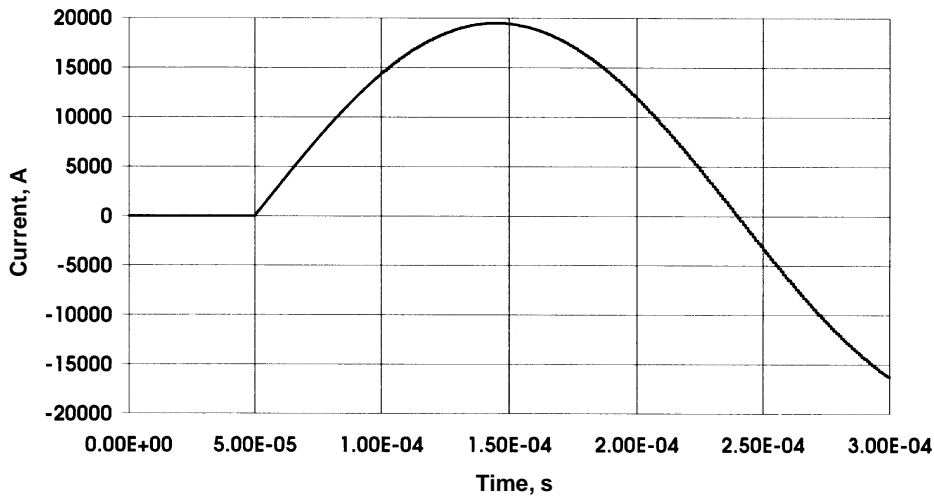

Figure 11-13—Current in circuit without damping resistor

11.1.8 Transient recovery voltage

Circuit breakers provide the mechanism to interrupt the short-circuit current during a system fault. When the breaker contacts open, the fault current is not interrupted instantaneously. Instead, an electric arc forms between the breaker contacts, which is maintained as long as there is enough current flowing. Since the fault current varies sinusoidally at the power frequency, the arc will extinguish at the first current zero. However, at the location of the arc, there are still hot, ionized gases and, if voltages exceeding the dielectric capability of the contact gap develop across the open contacts of the circuit breaker, it is possible that the arc will re-ignite. Circuit interruption is a race between the increase of dielectric strength of the contact gap of the circuit breaker or switch and the recovery voltage. The latter is essentially a characteristic of the circuit itself.

For inductive circuits, we know that the current lags the voltage by an angle less than ninety electrical degrees. Thus, when the current is zero, the voltage is at its maximum. This means

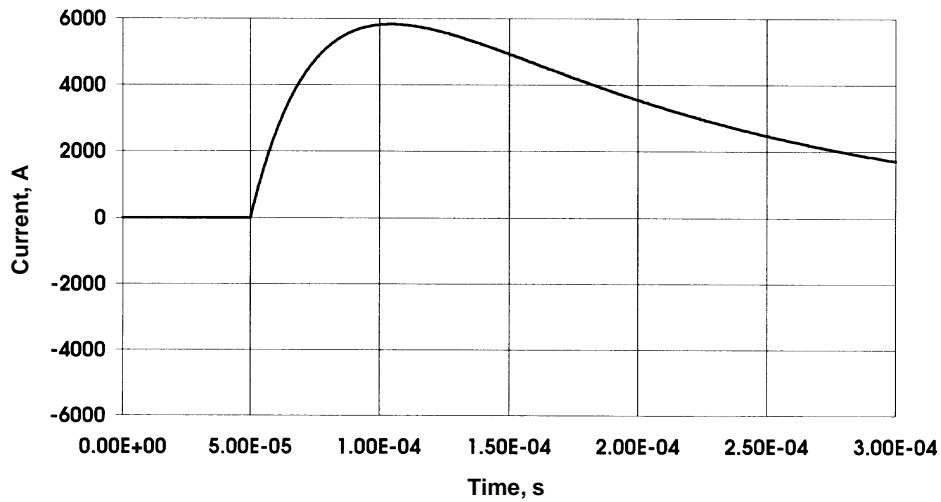

Figure 11-14—Current in circuit with damping resistor

that, immediately after interruption of the arc, a rapid buildup of voltage across the breaker contacts may cause the arc to re-ignite and re-establish the circuit. The rate by which the voltage across the breaker rises depends on the inductance and capacitance of the circuit.

The simplest form of single-phase circuit that is useful to illustrate this phenomenon is that shown in Figure 11-15.

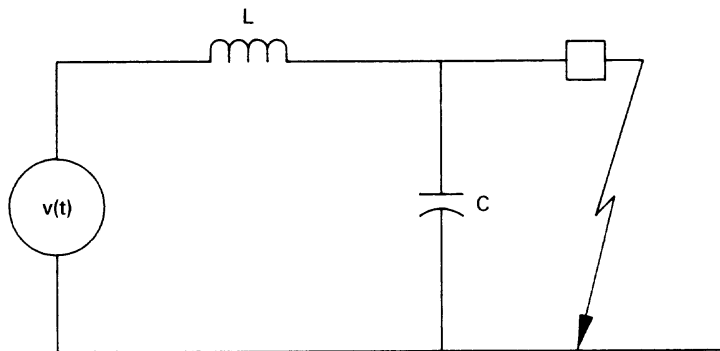

Figure 11-15—Simplified diagram to illustrate TRV

In the circuit, L is the inductance of the source and C is the natural capacitance of the circuit in the vicinity of the circuit breaker. It may include capacitance to ground through bushings,

current transformers, etc. The voltage source is assumed to vary sinusoidally and, since it is at its peak at the time the short-circuit current is interrupted, it can be expressed as

$$v(t) = \sqrt{2} \times V \times \cos(\omega t) \quad (11-57)$$

where ω is the power frequency in radians per second (rad/s). If the switch opens, the flow of current is interrupted at the first current zero and a voltage known as the transient recovery voltage (TRV) will appear across the breaker contacts. This voltage is essentially the voltage across the capacitance. It is zero during the fault but, when the circuit breaker opens to clear the fault, the voltage across the contacts builds up to approximately twice the peak of the voltage at the power frequency.

The equivalent circuit of Figure 11-15 may be analyzed by means of the Laplace transform. The network equation in the s -domain for $t = 0^+$ is

$$V(s) = I(s)sL - LI(0^-) + \frac{I(s)}{sC} \quad (11-58)$$

Solving the current $I(s)$ with $I(0^-) = 0$ (current interruption assumed to occur at zero current, no current chopping) yields the following:

$$I(s) = \frac{V(s)}{L} \left[\frac{s}{s^2 + \omega_0^2} \right] \quad (11-59)$$

Substituting $sCV_c(s)$ for $I(s)$, the result is

$$V_c(s) = V(s) \frac{\omega_0^2}{s^2 + \omega_0^2} \quad (11-60)$$

The Laplace transform of the driving function described by Equation (11-57) is

$$V(s) = V_{\max} \frac{s}{s^2 + \omega^2} \quad (11-61)$$

Combining Equations (11-60) and (11-61), the recovery voltage or the voltage across the capacitor is

$$V_c(s) = V_{\max} \frac{s\omega_0^2}{(s^2 + \omega^2)(s^2 + \omega_0^2)} \quad (11-62)$$

From the table of the inverse Laplace transforms, the transient response is

$$V_c(t) = \frac{V_{\max}}{2} \left[\cos(\omega t) - \cos(\omega_0 t) \right] \quad (11-63)$$

$$1 - \frac{\omega}{\omega_0^2}$$

The events before and after the fault are depicted in Figure 11-16 with damping. However, without damping as described by Equation (11-63), the recovery voltage reaches a maximum of twice the source voltage (the peak occurs at one half cycle of the natural frequency, after the switch is opened). This is true when the natural frequency is high as compared with the fundamental frequency and when losses are insignificant. Losses (damping) will reduce the maximum value of V_c , as shown in Figure 11-16.

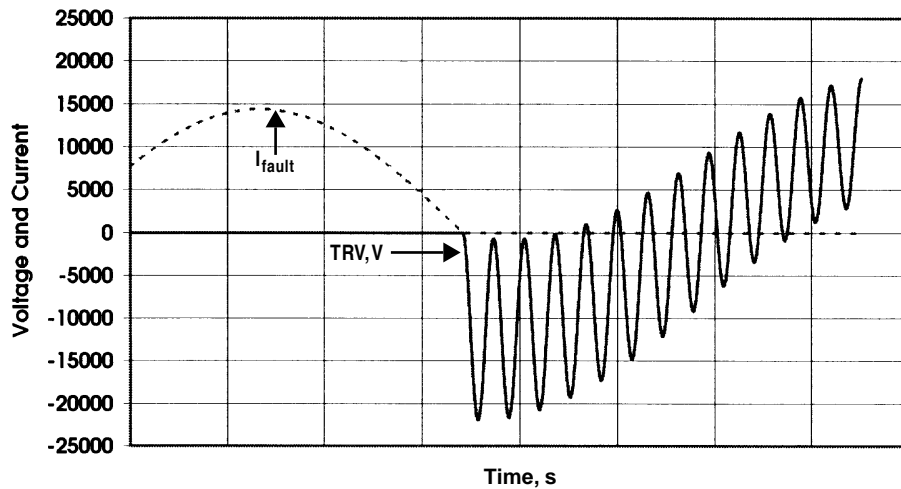

Figure 11-16—Transient recovery voltage

Upon interruption of the fault current by the circuit breaker, the source attempts to charge the capacitor voltage to the potential of the supply. As a matter of fact, without damping, the capacitor voltage will overshoot the supply voltage by the same amount as it started below. If the natural frequency of the circuit is high (L and C very small), the voltage across the breaker contacts will rise very rapidly. If this rate-of-rise exceeds the dielectric strength of the medium between the contacts, the breaker will not be able to sustain the voltage and re-ignition will occur.

11.1.9 Summary

The material covered thus far is by no means an exhaustive discussion of electrical transients in power systems. The objective of the foregoing material is to provide the reader with the

basic techniques required to perform simple switching transient calculations. We have seen that, even for simple series or parallel *RLC* circuits, the mathematical expressions can be quite cumbersome and very difficult to solve analytically. It is evident that any slight increase in circuit complexity will result in expressions very difficult to handle and solve by conventional methods.

Typical industrial power distribution systems will involve many series and parallel circuit combinations with very complex relationships. To set down and solve analytically the equations representing such a system would be a formidable task. This is when solutions by computer methods are most appropriate. Two of the most common computer methods are analog and digital. The analog computer makes use of scaled-down components, i.e., resistors, inductors, and capacitors, to model a particular system. The digital computer, on the other hand, utilizes computer programs (software packages) developed especially for the purpose of transient analysis.

11.2 Switching transient studies

11.2.1 Introduction

Unlike classical power system studies, i.e., short circuit, load flow, etc., switching transient studies are conducted less frequently in industrial power distribution systems. Capacitor and harmonic filter bank switching in industrial and utility systems account for most of such investigations, to assist in the resolution of certain transient behavioral questions in conjunction with the application or failure of a particular piece of equipment.

Two basic approaches present themselves in the determination and prediction of switching transient duties in electrical equipment: direct transient measurements (to be discussed later in this chapter) and computer modeling. The latter can be divided into transient network analyzer (TNA) and digital computer modeling.

In 11.1, some useful insights regarding the physical aspects prevailing in a circuit during a transient period were obtained with a minimum of mathematical complications. In fact, experienced transient analysts use known circuit-response patterns, based on a few basic fundamentals, to assess the general transient behavior of a particular circuit and to judge the validity of more complex switching transient results. Indeed, simple configurations consisting of linear circuit elements can be processed by hand as a first approximation. Beyond these relatively simple arrangements, the economics and effective determination of electrical power system transients require the utilization of TNAs or digital computer programs. These two approaches to the solution of complex switching transients in power systems are the subject of 11.2. Excerpts from actual switching transient studies are included.

11.2.2 Switching transient study objectives

The basic objectives of switching transient investigations are to identify and quantify transient duties that may arise in a system as a result of intentional or unintentional switching events, and to prescribe economical corrective measures whenever deemed necessary. The

results of a switching transient study can affect the operating procedures as well as the equipment in the system. The following include some specific broad objectives, one or more of which are included in a given study:

- a) Identify the nature of transient duties that can occur for any realistic switching operation. This includes determining the magnitude, duration, and frequency of the oscillations.
- b) Determine if abnormal transient duties are likely to be imposed on equipment by the inception and/or removal of faults.
- c) Recommend corrective measures to mitigate transient overvoltages and/or overcurrents. This may include solutions such as resistor pre-insertion, tuning reactors, appropriate system grounding, and application of surge arresters and surge-protective capacitors.
- d) Recommend alternative operating procedures, if necessary, to minimize transient duties.
- e) Document the study results on a case-by-case basis in readily understandable form for those responsible for design and operation. Such documentation usually includes reproduction of waveshape displays and interpretation of, at least, the limiting cases.

11.2.3 Control of switching transients

The philosophy of mitigation and control of switching transients revolves around the following:

- a) Minimizing the number and severity of the switching events
- b) Limitation of the rate of exchange of energy that prevails among system elements during the transient period
- c) Extraction of energy
- d) Shifting the resonant points to avoid amplification of particular offensive frequencies
- e) Provision of energy reservoirs to contain released or trapped energy within safe limits of current and voltage
- f) Provision of discharge paths for high-frequency currents resulting from switching

In practice, this is usually accomplished through one or more of the following methods:

- 1) Temporary insertion of resistance between circuit elements; for example, the insertion of resistors in circuit breakers
- 2) Synchronized closing control for vacuum and SF₆ breakers and switches
- 3) Inrush control reactors
- 4) Damping resistors in filter and surge protective circuits
- 5) Tuning reactors
- 6) Surge capacitors
- 7) Filters
- 8) Surge arresters
- 9) Necessary switching only, with properly maintained switching devices
- 10) Proper switching sequences

11.2.4 Transient network analyzer (TNA)

11.2.4.1 Introduction

Through the years, a small number of TNAs have been built for the purpose of performing transient analysis in power systems. A typical TNA is made of scaled-down power system component models, which are interconnected in such a way as to represent the actual system under study. The inductive, capacitive, and resistive characteristics of the various power system components are modeled with inductors, capacitors, and resistors in the analyzer. These have the same ohmic value as the actual components of the system at the power frequency. The analyzer generally operates in the range of 10–100 V_{rms} line-to-neutral, which represents 1.0 per-unit voltage on the actual system.

The model approach of the TNA finds its virtue in the relative ease with which individual components can duplicate their actual power system counterparts as compared with the difficulty of accurately representing combinations of nonlinear interconnected elements in a digital solution. Furthermore, the switching operation that produces the transients is under the direct control of the operator, and the circuit can easily be changed to show the effect of any parameter variation. TNA simulation is also faster than digital simulation especially for larger systems with many nonlinear elements to model.

11.2.4.2 Modeling techniques

Typical hardware used in a TNA to model the actual system components will be described now. However, it should be fully recognized that any specific set of components can be modeled in more than one way, and considerable judgment on the part of the TNA staff is necessary to select the optimum model for a given situation. Also, it should be recognized that, while there is a great similarity among the components of the various TNAs in existence today, there are also unique hardware approaches to any given system. The following is a general description of some of the hardware models.

- a) Transmission lines are modeled basically as a four-wire system, with three wires associated with the phase conductors and the fourth wire encompassing the effects of shield wire and earth return.
- b) Circuit breakers consist of a number of independent mercury-wetted relay contacts or solid-state electronic circuitry. The instant of both closing and opening of each individual switch can be controlled by the operator or the computer system. The model has the capability of simulating breaker actions like pre-striking, re-striking, and re-ignition.
- c) Shunt reactors can be totally electronic or analog with variable saturation characteristics and losses.
- d) Transformers are a critical part of the TNA. This is because many temporary overvoltages include the interaction of the nonlinear transformer magnetizing branch with the system inductance and capacitance. Modeling of the nonlinear magnetic representation of the transformer is very critical to analyzing ferroresonance and dynamic overvoltages. The model consists of both an array of inductors, configured

- and adjusted to represent the linear inductances of the transformer, and adjustable saturable reactors, representing the nonlinear portion of the saturation characteristics.
- e) Arresters of both silicon carbide and metal oxide can be modeled. The models for both types of arresters can be totally electronic and provide energy dissipation values to safely size the surge arresters.
 - f) Secondary arc, available in some TNA facilities, is a model that can simulate a fault arc and its action after the system circuit breakers are cleared.
 - g) Power sources can be three-phase motor-generator sets or three-phase electronic frequency converters. The short-circuit impedance of these sources is such that they appear as an infinite bus on the impedance base of the analyzer.
 - h) Synchronous machines can be either totally electronic or analog models, and are used to study the effects of load rejection or other events that could be strongly affected by the action of the synchronous machine.
 - i) Static var systems include an electronic control circuit, a thyristor-controlled reactor, and a fixed capacitor with harmonic filters. The control logic circuit monitors the three-phase voltages and currents and can be set to respond to either the voltage level, the power factor, or some combination of the two.
 - j) Series capacitor protective devices are used in conjunction with series compensated ac transmission lines. When a fault occurs, the voltage on the series capacitor rises to a high value unless it is bypassed by protective devices, such as power gap or metal-oxide varistors. The TNA can represent both of these devices.

11.2.5 Capacitor bank switching—TNA case study

11.2.5.1 Introduction

The following describes a case study in which a customer planned to install a total of 75 Mvar of switched capacitor banks at a 115 kV substation. The design called for two separately switched 37.5 Mvar banks to compensate for var loading and voltage drop that would occur in the system when power was being imported from other sources. Since this was the customer's first experience with capacitor bank installation above 34.5 kV, a request was made for a TNA study to determine the transient overvoltages that could result during energization of the capacitor banks.

11.2.5.2 Study objectives

The primary objective of this investigation was to determine if any switching surge overvoltage problems could be experienced when the proposed capacitor banks are added to the 115 kV substation. The system was modeled in the TNA to determine the switching surge voltages that can be generated during normal and abnormal switching conditions for the specific purpose of determining the following:

- a) The influence of the capacitor banks on the existing surge arresters and the application of protective devices at the buses where the capacitors will be located (see Figure 11-17)
- b) If pre-insertion resistors are required for the capacitor bank circuit breakers
- c) Current-limiting reactor requirements for both capacitor banks

- d) If any magnification of the capacitor switching transient voltages at remote system locations is a possibility
- e) If the system is susceptible to resonance due to added capacitor banks
- f) Traveling wave voltage effects at transformer terminated lines

11.2.5.3 Study results

The system being investigated is depicted in Figure 11-17. The proposed capacitor banks are connected to the 115 kV bus through the circuit breakers A and B. The entire investigation consisted of thirty-two different system configurations and switching operations. Due to space limitations, however, only the results of two of these cases will be presented here, namely the energization of both capacitor banks. The results of three-phase re-strike, fault initiation, line energization, etc., which were part of the study, will not be presented.

There are two or more output pages for each case investigated. The first page tabulates the system voltages recorded for the various system conditions as identified by the headings. They include both the temporary pre-switching, energizing, and post-switching voltages, as shown in Figure 11-18 (a), (b), and (c).

The succeeding pages display the statistical distribution curves of the transient voltages and/or the oscillograms of the voltage, current, and/or waveforms taken during the investigation, as shown in Figures 11-19, 11-20, and 11-21 for case 1. The results of case 2, that is, energization of capacitor bank 2, are shown in Figure 11-22 (a), (b), and (c), through Figure 11-26.

11.2.5.4 Discussion

A maximum transient voltage of 1.38 pu and 1.64 pu was calculated during energization of each of two 37.5 Mvar banks at the 115 kV bus (66.5 kV line-to-ground), locations 4 and 5. The 1.64 pu (154 kV peak line-to-neutral) was recorded in case 1, where the first of the two banks was energized. In case 2, the 1.38 pu (130 kV peak line-to-neutral) transient voltage was recorded as a result of energizing the second bank. In each of the two cases, the system was operating under normal conditions and the capacitor switches did not include any closing resistors or current-limiting reactors. Transient voltages of these magnitudes are generally not considered to be of sufficient magnitude to cause a 96 kV rated conventional gapped-type arrester to operate or to cause any undue stress to either a 90 kV or 96 kV rated metal-oxide type arrester, connected at the line-to-ground system voltage of 66.5 kV.

The switching operations of both capacitor banks did not cause any serious transient overvoltages at remote locations in the system and no resonant conditions were detected.

TEMPORARY LINE-TO-NEUTRAL VOLTAGE
CREST PER UNIT QUANTITIES
PRE-SWITCH VOLTAGES: BREAKER A OPEN.
CAPACITOR BANK #2 OUT OF SERVICE

<u>LOCATION</u>	<u>A</u>	<u>B</u>	<u>C</u>
1	1.05	1.05	1.05
2	1.05	1.05	1.05
3	1.05	1.05	1.05
4	0.01	0.01	0.01
5	0.01	0.02	0.01
10	1.05	1.05	1.05
11	1.05	1.05	1.05
12	1.05	1.05	1.05
13	1.05	1.05	1.05
14	1.05	1.05	1.05
15	1.05	1.05	1.05

(a) Pre-switching voltages

TEMPORARY LINE-TO-NEUTRAL VOLTAGE
CREST PER UNIT QUANTITIES
(* - DENOTES NONSINUSOIDAL)
POST-SWITCH VOLTAGES: BREAKER A CLOSED.
CAPACITOR BANK #2 OUT OF SERVICE

<u>LOCATION</u>	<u>A</u>	<u>B</u>	<u>C</u>
1	1.05	1.06	1.05
2	1.05	1.05	1.05
3	1.05	1.05	1.05
4	1.05	1.05	1.05
5	0.01	0.01	0.01
10	1.06	1.06	1.06
11	1.06	1.06	1.06
12	1.05	1.05	1.05
13	1.06	1.05	1.05*
14	1.05	1.05	1.05
15	1.06	1.06	1.06

(b) Energizing voltages

SWITCHING LINE-TO-NEUTRAL VOLTAGE
CREST PER UNIT QUANTITIES
ENERGIZING CAPACITOR BANK #1
CAPACITOR BANK #2 OUT OF SERVICE

<u>LOCATION</u>	<u>A</u>	<u>B</u>	<u>C</u>
1	1.40	1.10	1.64
2	1.40	1.10	1.64
3	1.40	1.10	1.64
4	1.40	1.10	1.64
5	0.01	0.01	0.01
10	1.16	1.12	1.34
11	1.14	1.12	1.33
12	1.36	1.08	1.69
13	1.52	1.10	1.80
14	1.36	1.07	1.60
15	1.66	1.23	1.86

(c) Post-switching voltages

Figure 11-18—System voltages—Case 1

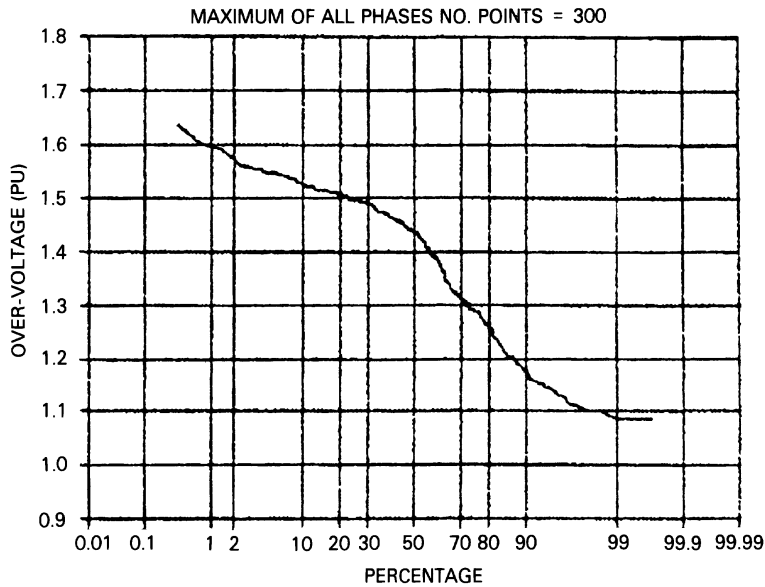

Figure 11-19—Probability distribution—Case 1

11.2.6 Electromagnetic transients program (EMTP)

11.2.6.1 Introduction

EMTP is a software package that can be used for single-phase and multiphase networks to calculate either steady-state phasor values or electromagnetic switching transients. The results can be either printed or plotted.

11.2.6.2 Network and device representation

The program allows for arbitrary connection of the following elements:

- a) Lumped resistance, inductance, and capacitance
- b) Multiphase (π) circuits, when the elements R , L , and C become symmetric matrixes
- c) Transposed and untransposed distributed parameter transmission lines with wave propagation represented either as distortionless, or as lossy through lumped resistance approximation
- d) Nonlinear resistance with a single-valued, monotonically increasing characteristics
- e) Nonlinear inductance with single-valued, monotonically increasing characteristics

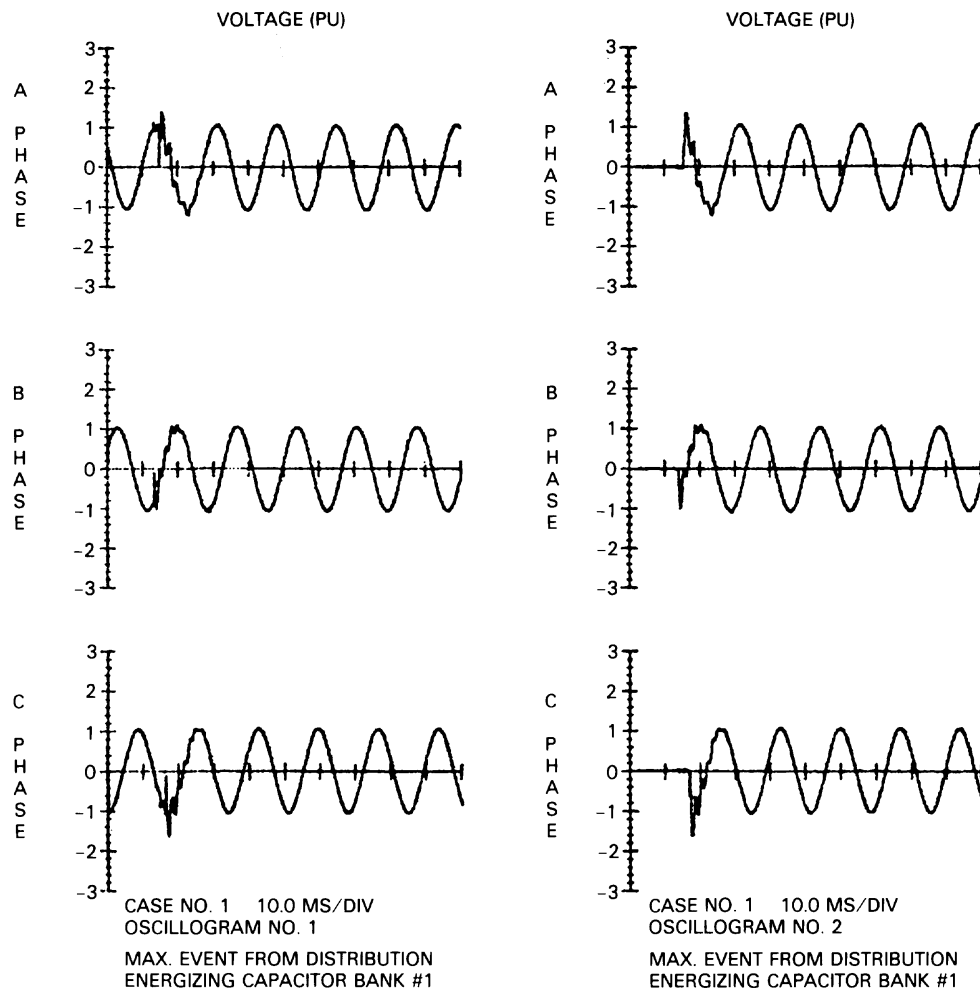

Figure 11-20—Voltage oscillations, locations 1 and 4—Case 1

- f) Time-varying resistance
- g) Switches with various switching criteria to simulate circuit breakers, spark gaps, diodes, and other network connection options
- h) Voltage and current sources representing standard mathematical functions, such as sinusoidals, surge functions, steps, ramps, etc. In addition, point-by-point sources as a function of time can be specified by the user.
- i) Single- and three-phase, two- or three-winding transformers

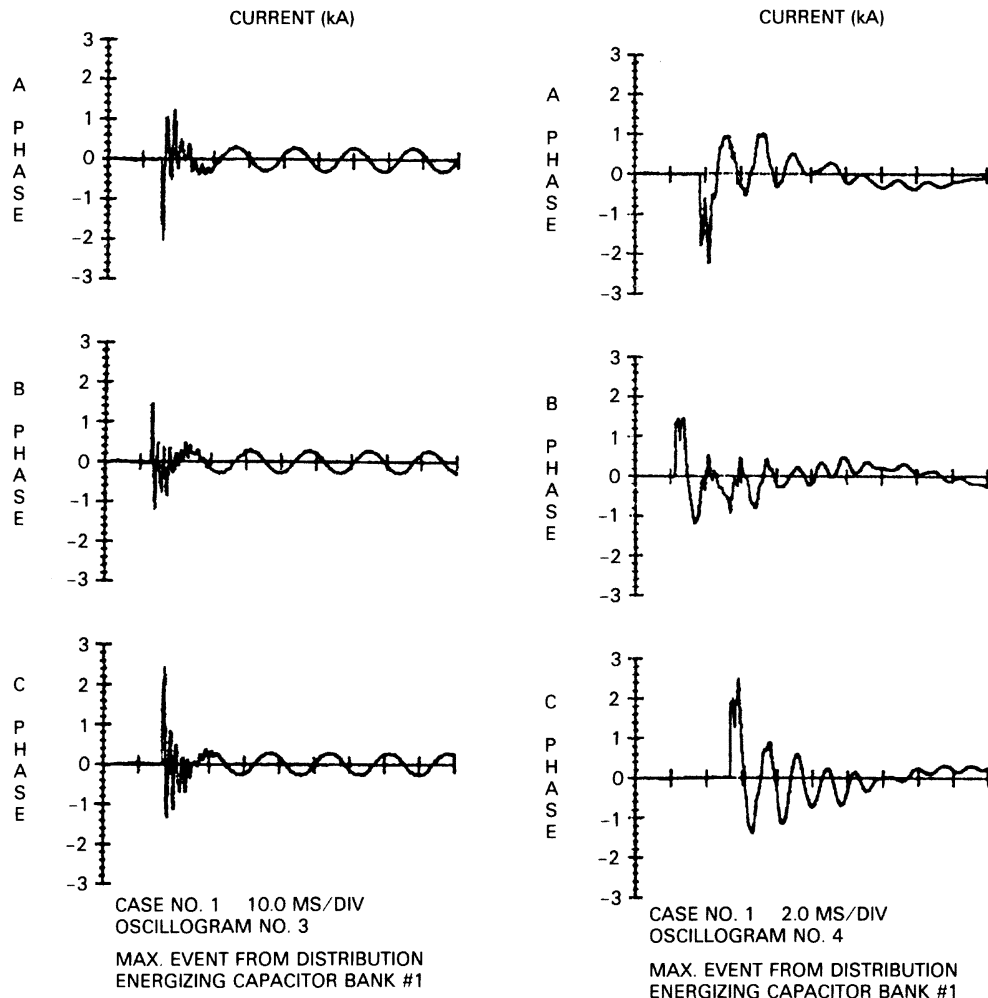

Figure 11-21—Current oscillograms, location 4—Case 1

11.2.7 Capacitor bank switching—EMTP case study

11.2.7.1 Introduction

As part of a modernization program that included the addition of two paper machine drives to the existing system, it was determined that a 10 Mvar capacitor bank was required to improve the plant power factor and the system voltage profile. Further analysis also indicated the need for a tuning reactor in series with the capacitor bank in order to minimize the effects of harmonic resonance problems. Because of recent plant outages caused by what appeared to be normal switching operations, and because the proposed capacitor bank would require

TEMPORARY LINE-TO-NEUTRAL VOLTAGE
CREST PER UNIT QUANTITIES
(* - DENOTES NONSINUSOIDAL)
PRE-SWITCH VOLTAGES: BREAKER B OPEN.
CAPACITOR BANK #1 IN SERVICE

<u>LOCATION</u>	<u>A</u>	<u>B</u>	<u>C</u>
1	1.06	1.04	1.05
2	1.05	1.05	1.05
3	1.05	1.05	1.05
4	1.05	1.05	1.05
5	0.03	0.04	0.04
10	1.05	1.05	1.05
11	1.05	1.05	1.05
12	1.06	1.05	1.04
13	1.05	1.05	1.05*
14	1.05	1.05	1.05
15	1.05	1.06	1.04

(a) Pre-switching voltages

TEMPORARY LINE-TO-NEUTRAL VOLTAGE
CREST PER UNIT QUANTITIES
(* - DENOTES NONSINUSOIDAL)
PRE-SWITCH VOLTAGES: BREAKER B CLOSED.
CAPACITOR BANK #1 IN SERVICE

<u>LOCATION</u>	<u>A</u>	<u>B</u>	<u>C</u>
1	1.06	1.06	1.05
2	1.06	1.05	1.05
3	1.06	1.05	1.05
4	1.06	1.06	1.04
5	1.06	1.05	1.05
10	1.08	1.07	1.07
11	1.06	1.07	1.06
12	1.06	1.06	1.05
13	1.06	1.07	1.05*
14	1.06	1.06	1.05
15	1.07	1.07	1.06

(b) Energizing voltages

SWITCHING LINE-TO-NEUTRAL VOLTAGE
CREST PER UNIT QUANTITIES
ENERGIZING CAPACITOR BANK #2
CAPACITOR BANK #1 IN SERVICE

<u>LOCATION</u>	<u>A</u>	<u>B</u>	<u>C</u>
1	1.10	1.12	1.38
2	1.10	1.12	1.38
3	1.10	1.12	1.38
4	1.10	1.12	1.38
5	1.10	1.12	1.38
10	1.13	1.12	1.18
11	1.11	1.10	1.16
12	1.09	1.09	1.40
13	1.14	1.11	1.42
14	1.10	1.11	1.38
15	1.14	1.12	1.39

(c) Post-switching voltages

Figure 11-22—System voltages—Case 2

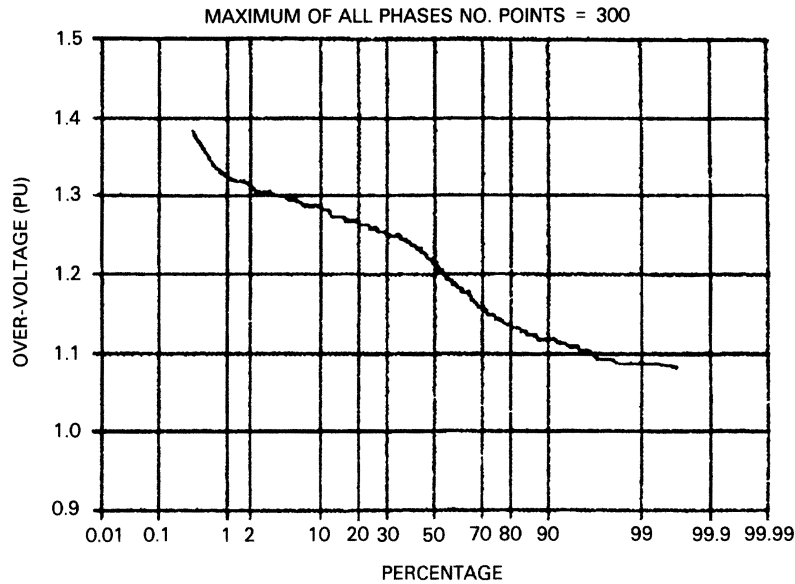

Figure 11-23—Probability distribution—Case 2

frequent switching to meet system voltage and power factor requirements, the customer requested that a switching transient investigation be conducted to determine the voltage and current waveforms associated with the switching of the proposed capacitor bank.

11.2.7.2 Study objectives

The objectives of the study were to assist the customer in evaluating the effect of filter bank switching transients and in determining the solution to minimize these effects on the electrical system and equipment. Specifically, the study addressed the transient voltages and current waveforms during energization of the filter bank and the effects that these transients might have on the slip energy recovery drive and on the proposed dc drives for the new paper machines.

11.2.7.3 Circuit model and cases studied

The study circuit and pertinent system parameters used in the study are depicted in Figure 11-27.

Table 11-1 describes the cases studied. Various system configurations were investigated to determine the transient voltage waveforms associated with the energization of the filter bank. The switching operation for the cases investigated (as listed in Table 11-1) was initiated when the phase-to-phase voltage (V_{a-b}) at the STPT bus was at its peak ($t = 8.4$ ms). When resistor pre-insertion is used, it remains in the circuit for a period of three cycles and then is shorted

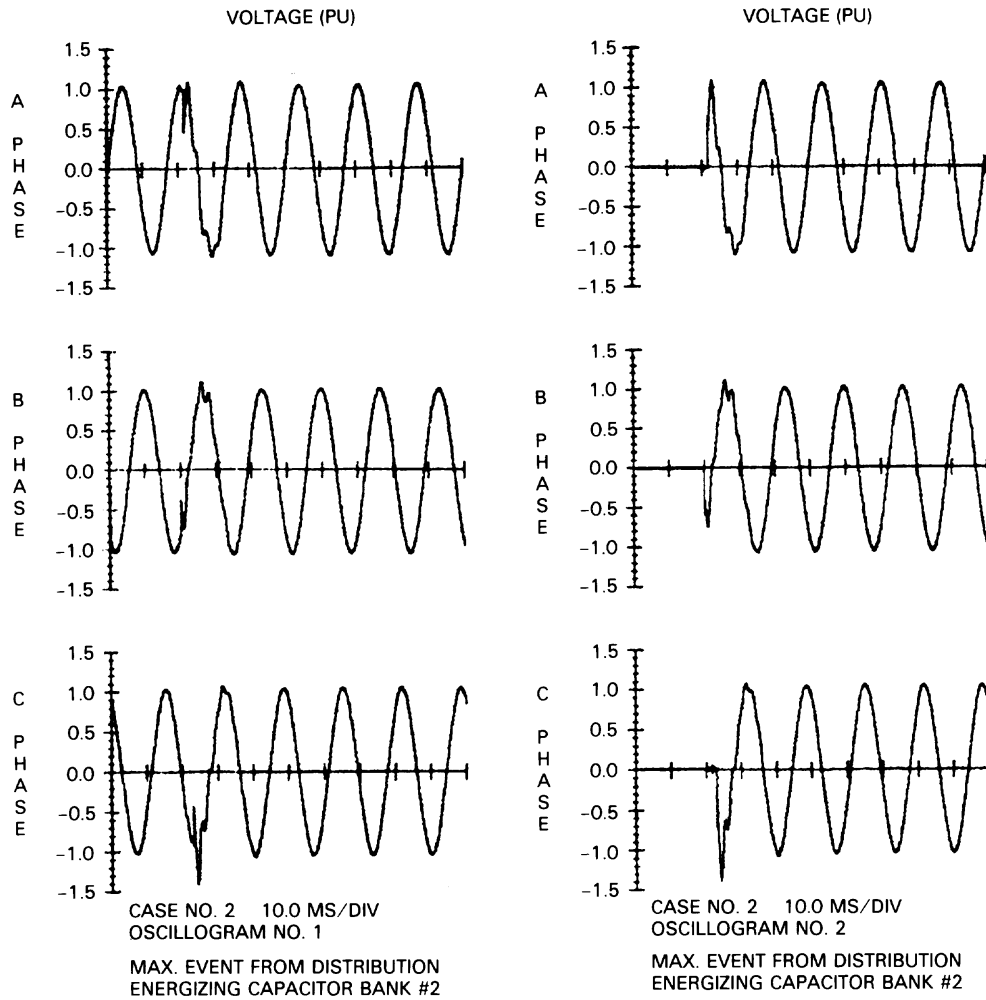

Figure 11-24—Voltage oscillograms, locations 3 and 5—Case 2

out by a second switching operation, as depicted in the single-line diagram shown in Figure 11-27.

11.2.7.4 Study results and discussion

Selected transient voltage waveforms that were calculated and plotted by the program for cases 1, 8, and 9 are shown in Figure 11-28 through Figure 11-33.

Tables 11-2 and 11-3 summarize the results of all cases, for the worst peak overvoltages calculated, in kilovolts and in per units, respectively.

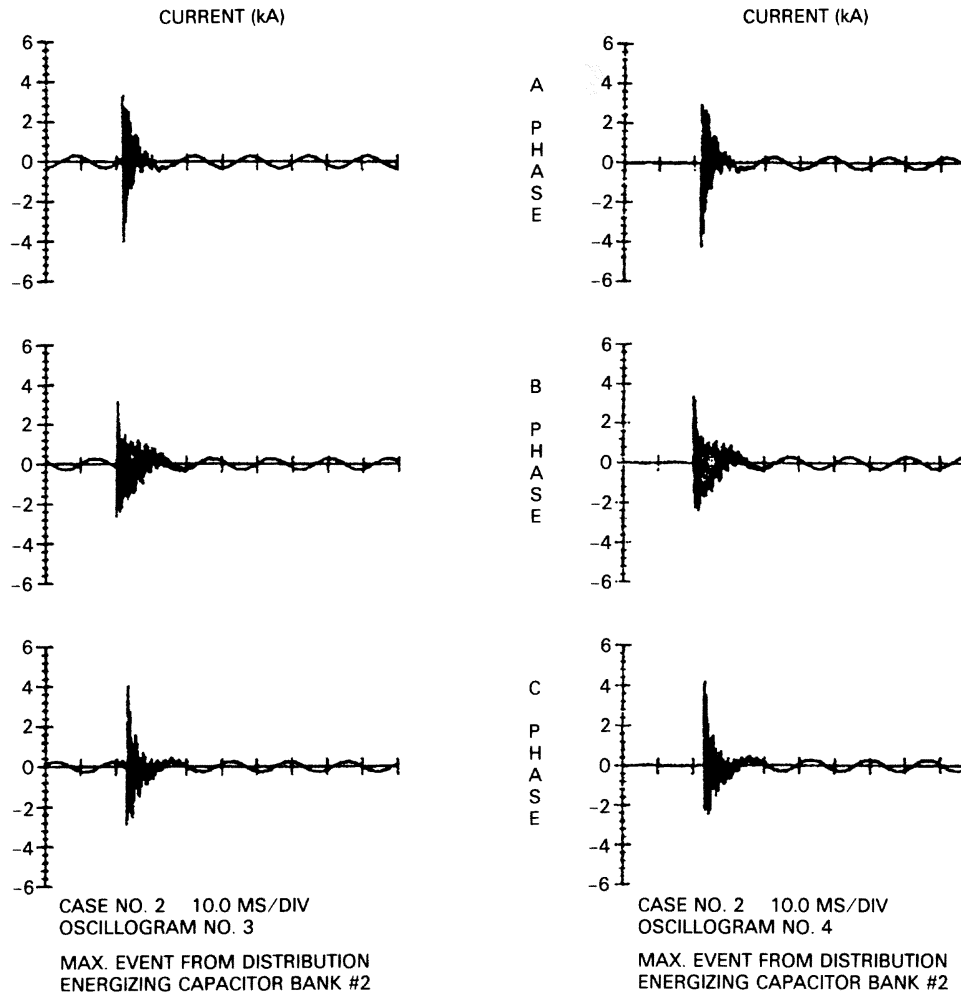
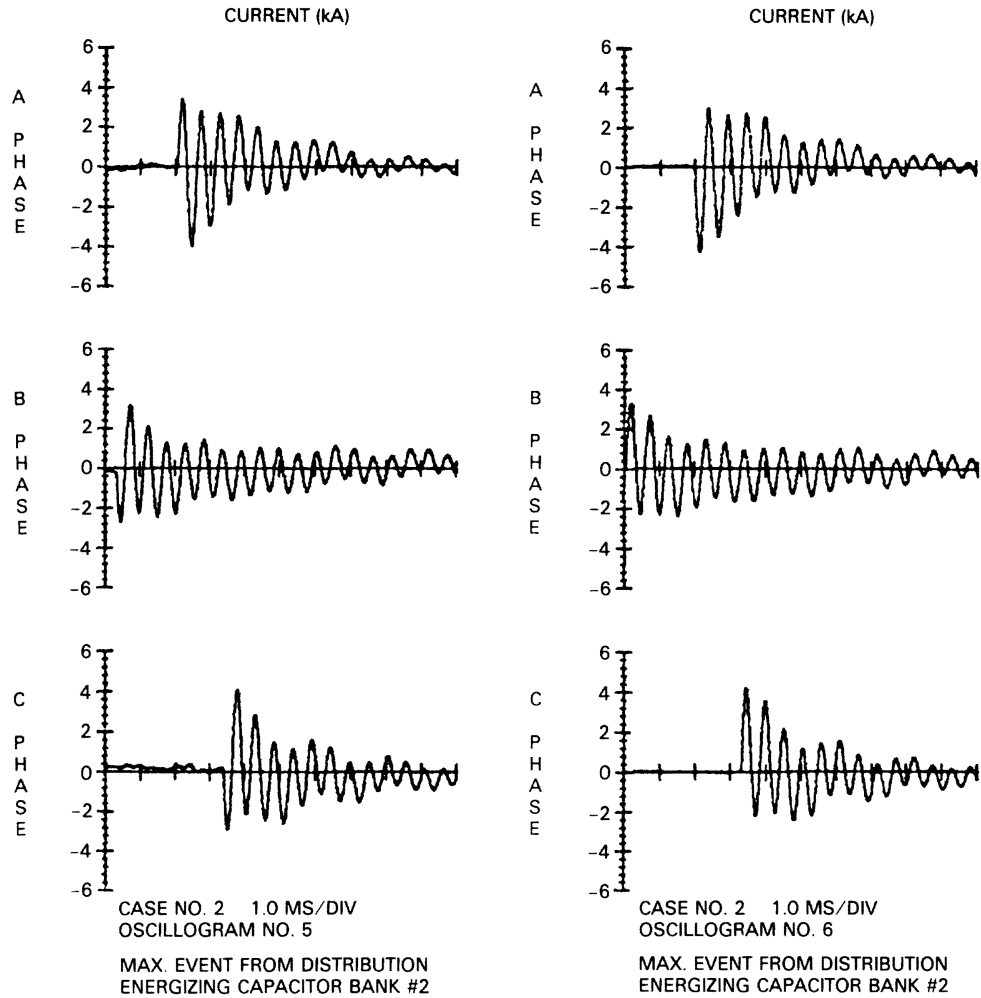

Figure 11-25—Current oscillograms, locations 4 and 5—Case 2

The following are some observations:

- a) Removal of the 325 kvar capacitor bank on bus L135 (case 2) eliminates the high frequency oscillations (1000 Hz) experienced in case 1.
- b) The transients are substantially reduced when the 10 Mvar filter bank is divided into two 5 Mvar banks (cases 4 and 5).
- c) The transient decay is faster when pre-insertion resistors are used (cases 5, 8, and 9).



**Figure 11-26—Current oscillograms, locations 4 and 5—Case 2
expanded time scale**

- d) The magnitude of the transient overvoltages is greatly reduced when the 10 Mvar bank is divided into two 5 Mvar banks and when resistor pre-insertion (5.2Ω) is used during energization (cases 8 and 9).

11.2.8 Summary

Complete switching transient study documentation includes not only detailed individual case study results for transient responses associated with various arrangements and conditions surveyed, but also analysis, recommendations, and conclusions of the study. The study report

Table 11-1—Filter energization—Cases studied

Case	Description
1	Energization of 10 Mvar filter bank
2	Energization of 10 Mvar filter bank, with 325 kvar capacitor bank disconnected
3	10 Mvar filter bank divided into two 5 Mvar banks, energization of first 5 Mvar filter bank
4	Energization of second 5 Mvar filter bank
5	Energization of 10 Mvar filter bank with resistor pre-insertion; ($R = 2.6 \Omega$ for 3 cycles)
6	Energization of 10 Mvar filter bank with resistor pre-insertion; ($R = 26 \Omega$ for 3 cycles)
7	Energization of 10 Mvar filter bank with resistor pre-insertion; ($R = 13 \Omega$ for 3 cycles)
8	10 Mvar filter bank divided into two 5 Mvar banks, energization of first 5 Mvar filter bank, with resistor pre-insertion; ($R = 5.2 \Omega$ for 3 cycles)
9	Energization of second 5 Mvar filter bank; with resistor pre-insertion; ($R = 5.2 \Omega$ for 3 cycles)

also includes a complete listing of parameters (R , L , and C) of various system components, characteristics of protective devices, and a description of any unusual or special-representations used in the study.

11.2.9 Switching transient problem areas

Switching of predominantly reactive equipment represents the greatest potential for creating excessive transient duties. Principal offending situations are switching capacitor banks with inadequate or malfunctioning switching devices and energizing and de-energizing transformers with the same switching deficiencies. Capacitors can store, trap, and suddenly release relatively large quantities of energy. Similarly, highly inductive equipment possesses an energy storage capability that can also release large quantities of electromagnetic energy during a rapid current decay. Since transient voltages and currents arise in conjunction with energy redistribution following a switching event, the greater the energy storage in associated system elements, the greater the transient magnitudes become.

Generalized switching transient studies have provided many important criteria to enable system designers to avoid excessive transients in most common circumstances. The criteria for proper system grounding to avoid transient overvoltages during a ground fault are a prime example. There are also several not very common potential transient problem areas that are

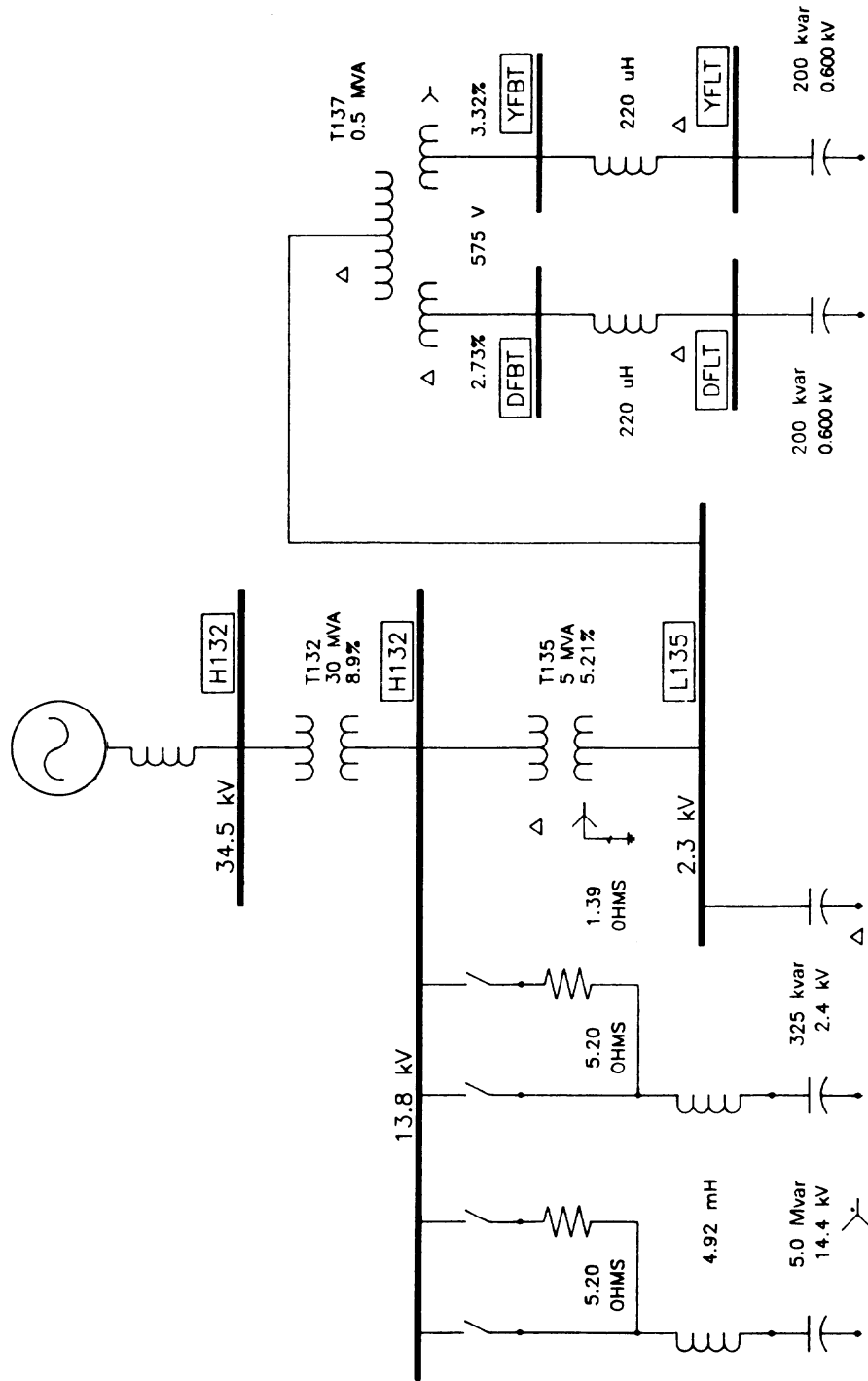

Figure 11-27—System single-line diagram

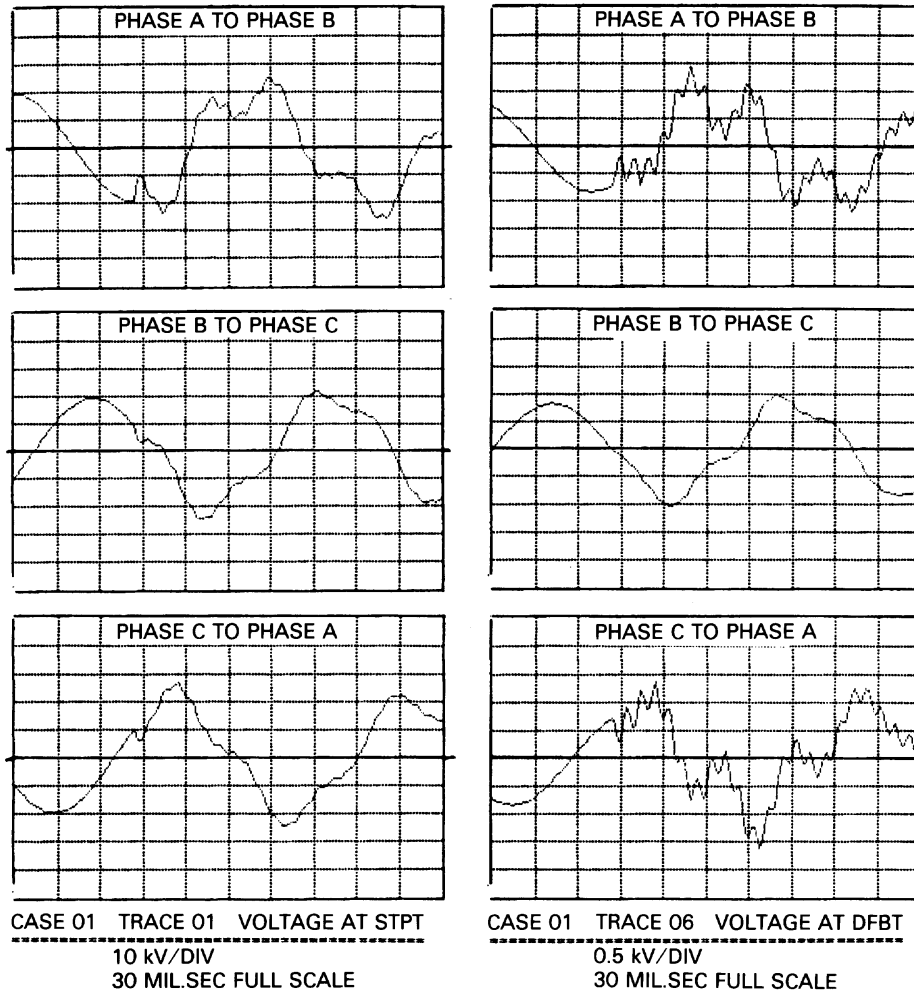

Figure 11-28—Voltage oscillograms at STPT and DFBT buses—Case 1

analyzed on an individual basis. The following is a partial list of transient-related problems, which can and have been analyzed through computer modeling:

- a) Energizing and de-energizing transients in arc furnace installations
- b) Ferroresonance transients
- c) Lightning and switching surge response of motors, generators, transformers, transmission towers, cables, etc.
- d) Lightning surges in complex station arrangements to determine optimum surge arrester location
- e) Propagation of switching surge through transformer and rotating machine windings

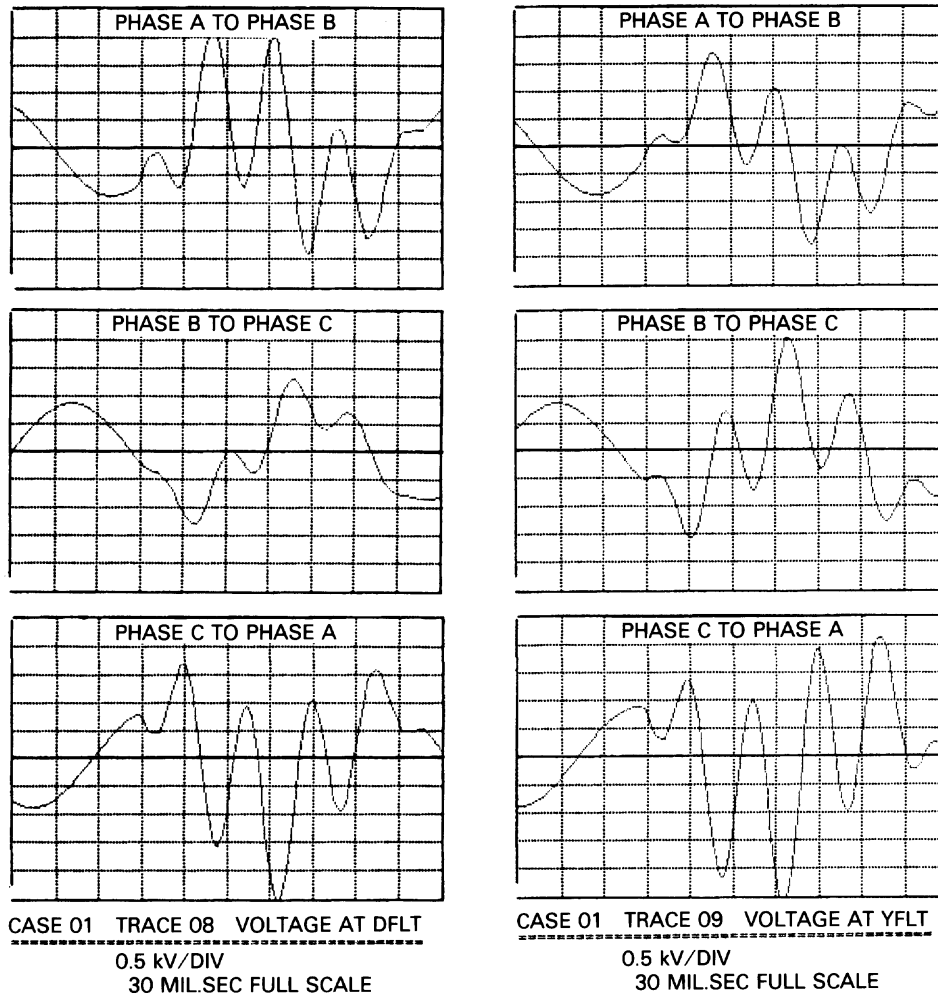

Figure 11-29—Voltage oscillograms at DFLT and YFLT buses—Case 1

- f) Switching of capacitors
- g) Restrike phenomena during line dropping and capacitor de-energization
- h) Neutral instability and reversed phase rotation
- i) Energizing and reclosing transients on lines and cables
- j) Switching surge reduction by means of controlled closing of circuit breaker, resistor pre-insertion, etc.
- k) Statistical distribution of switching surges
- l) Transient recovery voltage on distribution and transmission systems
- m) Voltage flicker

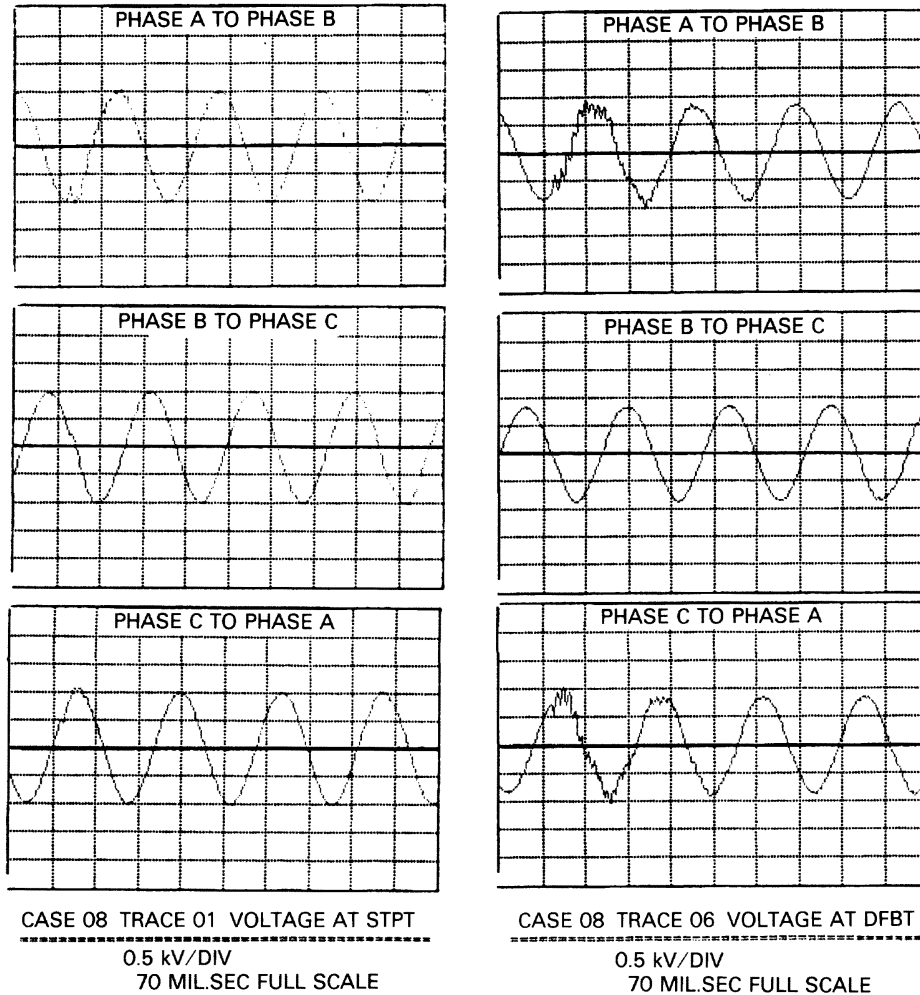

Figure 11-30—Voltage oscillograms at STPT and DFBT buses—Case 8

The studies presented in this chapter have been primarily based on closing or opening of electrical circuits and, therefore, are not generally applicable to transfer switching in emergency and standby power systems. Here, significant transients often occur when inductive loads are rapidly transferred between two out-of-phase sources. Transients can also occur when four-pole transfer switches are both used for line and neutral switching, as may be necessary for separately derived systems. Typical solutions for such problem areas often require transfer switch designs that include in-phase monitors and overlapping neutral conductor switching. For further reading on this subject, see IEEE Std 446-1995.¹

¹Information on references can be found in 11.5.

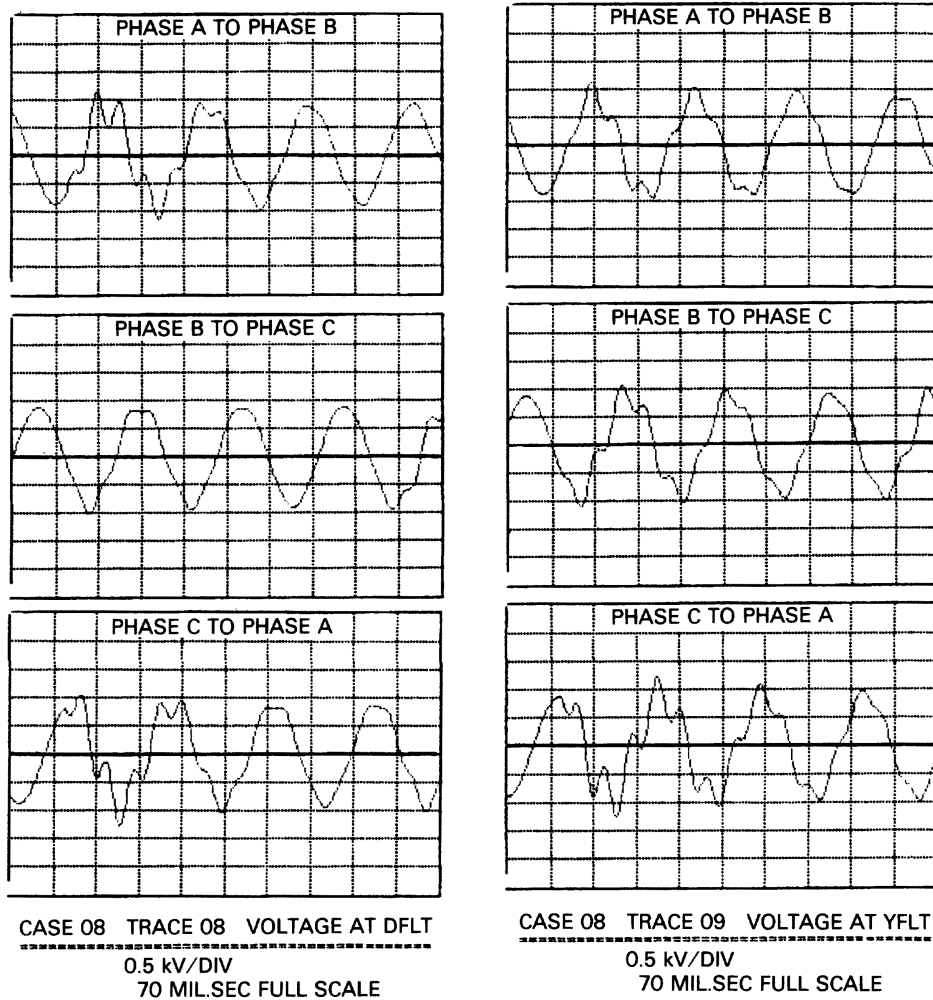

Figure 11-31—Voltage oscillograms at DFLT and YFLT buses—Case 8

The behavior of transformer and machine windings under transient conditions is also an area of great concern. Due to the complexities involved, it would be almost impossible to cover the subject in this chapter. For those interested, Chapter 11 of Greenwood [B5]² covers the subject in greater detail. Mazur [B6] and White [B11] also cover transients in transformers and rotating machines.

²The numbers in brackets correspond to those of the bibliography in 11.6.

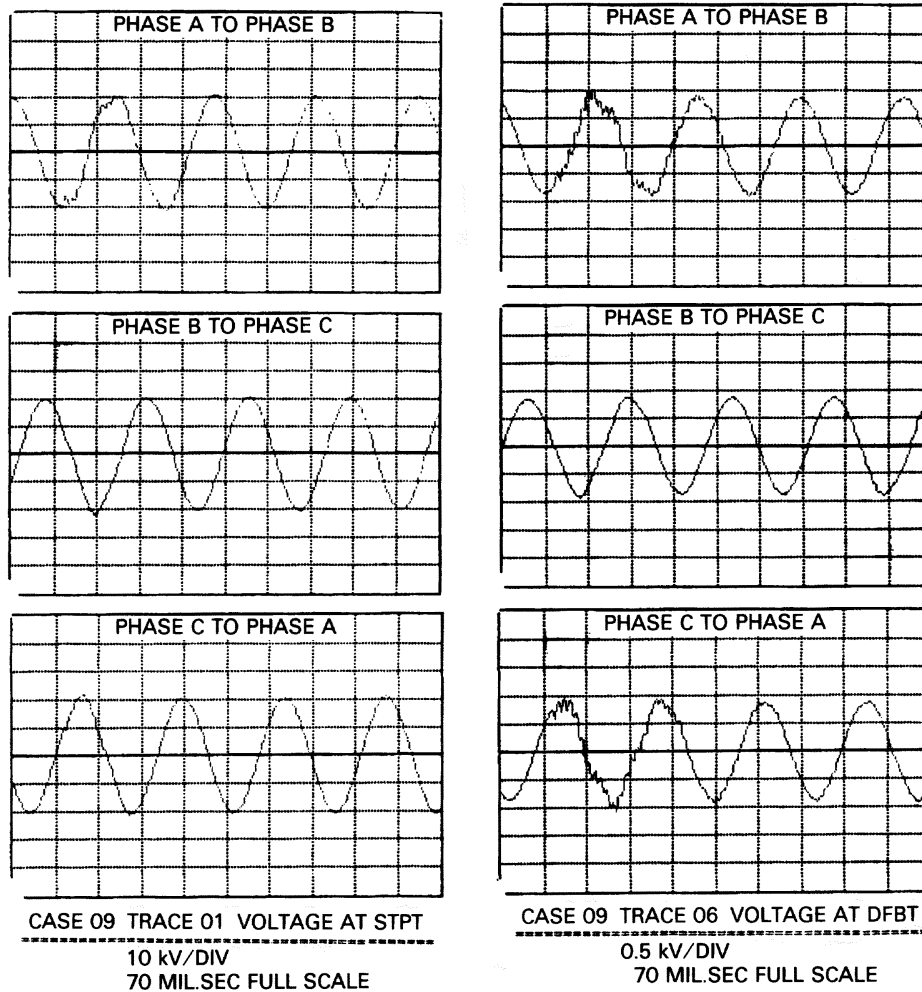

Figure 11-32—Voltage oscillograms at STPT and DFLT buses—Case 9

11.3 Switching transients—field measurements

11.3.1 Introduction

The choice of measuring equipment, auxiliary equipment selection, and techniques of setup and operation are in the domain of practiced measurement specialists. No attempt will be made here to delve into such matters in detail, except from the standpoint of conveying the depth of involvement entailed by switching transient measurements and from the standpoint of planning a measurement program to secure reliable transient information of sufficient scope for the intended purpose.

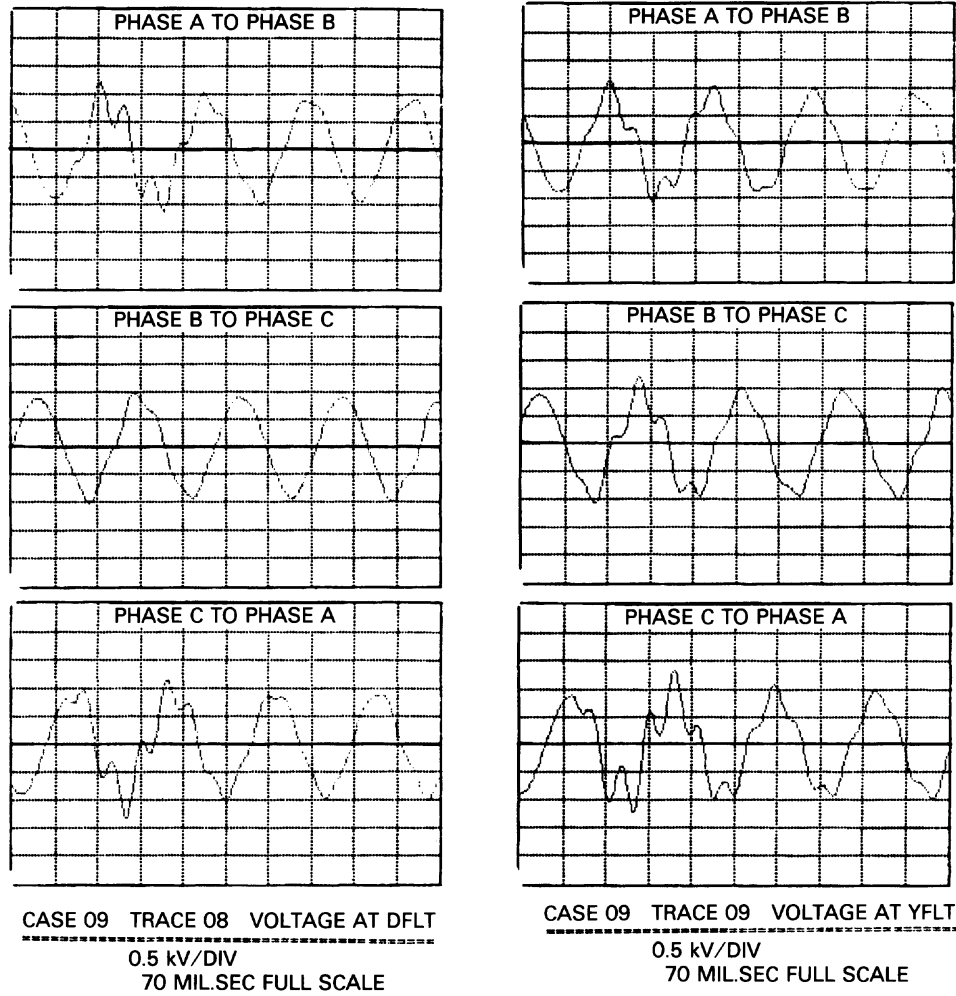

Figure 11-33—Voltage oscillograms at DFLT and YFLT buses—Case 9

Field measurements seldom, if ever, include fault switching, and often, recommended corrective measures are not in place to be used in the test program except on a followup basis. For systems still in the design stage or when fault switching is required, the transient response is usually obtained with the aid of a TNA or a digital computer program. There are basically three types of transients to consider in field measurements:

- a) Switching
- b) Recurrent
- c) Random

Table 11-2—Summary of maximum calculated voltage in kilovolts

Bus	Study case								
	1	2	3	4	5	6	7	8	9
STPT	26.57	25.71	25.22	22.92	22.30	26.73	25.30	21.45	22.11
L135	5.70	4.79	4.83	4.29	5.02	5.43	4.71	4.40	3.95
L135G	3.70	2.54	2.78	2.07	2.62	2.96	2.74	2.25	2.20
L136	0.95	0.93	0.89	0.81	0.86	N/A	0.87	0.80	0.98
L136G	0.53	0.49	0.47	0.47	0.45	N/A	0.52	0.43	0.44
DFBT	1.62	1.43	1.33	1.14	1.15	N/A	1.25	1.04	1.06
YFBT	1.53	1.40	1.39	1.17	0.96	N/A	1.28	0.98	1.02
DFLT	2.57	2.52	2.37	1.75	1.52	N/A	1.89	1.27	1.32
YFLT	2.70	2.64	2.74	1.73	1.51	N/A	2.00	1.26	1.34

Table 11-3—Summary of maximum calculated voltage in per units

Bus	Study case								
	1	2	3	4	5	6	7	8	9
STPT	1.36	1.32	1.29	1.17	1.14	1.37	1.30	1.10	1.13
L135	1.75	1.47	1.49	1.32	1.54	1.67	1.45	1.35	1.21
L135G	1.63	1.35	1.48	1.10	1.39	1.58	1.46	1.20	1.17
L136	1.39	1.36	1.31	1.19	1.27	N/A	1.28	1.18	1.44
L136G	1.36	1.25	1.20	1.20	1.14	N/A	1.32	1.10	1.13
DFBT	1.99	1.76	1.63	1.40	1.41	N/A	1.53	1.28	1.31
YFBT	1.88	1.72	1.71	1.43	1.18	N/A	1.57	1.20	1.25
DFLT	3.16	3.10	2.92	2.15	1.87	N/A	2.32	1.56	1.62
YFLT	3.33	3.25	3.37	2.13	1.86	N/A	2.46	1.55	1.65

The first category includes transients incurred when switching a device on or off. The second category covers the transients occurring regularly, for example, commutation transients. The final category refers to transients are those of usually unknown origin, generated by extraneous operations on the system. These may include inception and interruption of faults, lightning strikes, etc. To detect and/or record random transients, it is necessary to monitor the system continuously.

11.3.2 Signal derivation

The ideal result of a transient measurement, or for that matter, any measurement at all, is to obtain a perfect replica of the transient voltage and current as a function of time. Quite often, the transient quantity to be measured is not obtained directly and must be converted, by means of transducers, to a voltage or current signal that can be safely recorded. However, measurements in a system cannot be taken without disturbing it to some extent. For example, if a shunt is used to measure current, in reality, voltage is being measured across the shunt to which the current gives rise. This voltage is frequently assumed to be proportional to the current, when, in fact, this is not always true with transient currents. Or, if the voltage to be measured is too great to be handled safely, appropriate attenuation must be used. In steady-state measurements, such errors are usually insignificant. But in transient measurements, this is more difficult to do. Therefore, since switching transients involve natural frequencies of a very wide range (several orders of magnitude), signal sourcing must be by special current transformers (CTs), non-inductive resistance dividers, non-inductive current shunts, or compensated capacitor dividers, in order to minimize errors. While conventional CTs and potential transformers (PTs) can be suitable for harmonic measurements, their frequency response is usually inadequate for switching transient measurements.

11.3.3 Signal circuits, terminations, and grounding

Due to the very high currents with associated high magnetic flux concentrations, it is essential that signal circuitry be extremely well shielded and constructed to be as interference-free as possible. Double-shielded low loss coaxial cable is satisfactory for this purpose. Additionally, it is essential that signal circuit terminations be made carefully with high-quality hardware and assure proper impedance match in order to avoid spurious reflections.

It is desirable that signal circuits and instruments be laboratory-tested as an assembly before field measurements are undertaken. This testing should include the injection of a known wave into the input end of the signal circuit and comparison of this waveshape with that of the receiving instruments. Only after a close agreement between the two waveshapes is achieved should the assembly be approved for switching transient measurements. These tests also aid overall calibration.

All the components of the measurement system should be grounded via a continuous conducting grounding system of lowest practical inductance to minimize internally induced voltages. The grounding system should be configured to avoid ground loops that can result in injection of noise. Where signal cables are unusually long, excessive voltages can become

induced in their shields. Industrial switching transient measurement systems have not, as yet, involved such cases.

11.3.4 Equipment for measuring transients

The complement of instruments used depends on the circumstances and purpose of the test program. Major items comprising the total complement of display and recording instrumentation for transient measurements are one or more of the following:

- a) One or more oscilloscopes, including a storage-type scope with multichannel switching capability. When presence of the highest speed transients (that is, those with front times of less than a microsecond) is suspected, a high speed, single trace surge test oscilloscope with direct cathode ray tube (CRT) connections is sometimes used to record such transients with the least possible distortion.
- b) Multichannel magnetic light beam oscillograph with high input impedance amplifiers.
- c) Peak-holding digital readout memory voltmeter (sometimes called “peakpicker”) that is manually reset.

The occurrence of most electrical transients is quite unpredictable. To detect and/or record random disturbances, it is necessary to monitor the circuit on a continuous basis. There are many instruments available in the market today for this purpose. Most of these instruments are computer based; that is, the information can be captured digitally and later retrieved for display or computer manipulation. These instruments vary in sophistication depending on the type and speed of transient measurements that are of interest.

11.4 Typical circuit parameters for transient studies

11.4.1 Introduction

Tables 11-4 through 11-11 and Figures 11-34 through 11-39 depict typical parameters used in switching transient analysis. Compared to conventional power system studies, switching transient analysis data requirements are often more detailed and specific. These requirements remain basically unchanged regardless of the basic analysis tools and aids that are employed, whether they are digital computer or transient network analyzers.

To determine the transient response of a circuit to a specific form of excitation, it is first necessary to reduce the network to its simplest form composed of R s, L s, and C s. After solving the circuit equations for the desired unknown, values must be assigned to the various circuit elements in order to determine the response of the circuit.

11.4.2 System and equipment data requirements

The following generalized data listed encompass virtually all information areas required in an industrial power system switching transient study:

Table 11-4—Approximate positive sequence reactance values for standard 25- to 60-cycle, self-cooled, two-winding power transformers

Rated high voltage	Rated low voltage	Percent reactance					
		Fully insulated		With reduced neutral insulation		Reduced one insulation class with reduced neutral insulation	
		Min.	Max.	Min.	Max.	Min.	Max.
2 400–15 000	440–15 000	4.5	7.0				
15 001–25 000	440–15 000	5.5	8.0				
25 001–34 500	440–15 000	6.0	8.0				
	15 001–25 000	6.5	9.0				
34 501–46 000	440–15 000	6.5	9.0				
	25 001–34 500	7.0	10.0				
46 001–69 000	400–34 500	7.0	10.5				
	34 501–46 000	8.0	11.0				
69 001–92 000	440–34 500	7.5	10.5	7.0	10.0		
	34 501–69 000	8.5	12.5	8.0	11.5		
92 001–115 000	440–34 500	8.0	12.0	7.5	10.5	7.0	10.0
	34 501–69 000	9.0	14.0	8.5	12.5	8.0	11.5
	69 001–92 000	10.0	15.5	9.5	14.0	9.0	13.0
115 001–138 000	440–34 500	8.5	13.0	8.0	12.0	7.5	10.5
	34 501–69 000	9.5	15.0	9.0	14.0	8.5	12.0
	69 001–115 000	10.5	17.0	10.0	16.0	9.5	14.0
138 001–161 000	440–46 000	9.0	14.0	8.5	13.0	8.0	12.0
	46 001–92 000	10.5	16.0	9.5	15.0	9.0	14.0
	92 001–132 000	11.5	18.0	10.5	17.0	10.0	16.0
161 001–196 000	400–46 000	10.0	15.0	9.0	14.0	8.5	13.0
	46 001–92 000	11.5	17.0	10.5	16.0	9.5	15.0
	92 001–161 000	12.5	19.0	11.5	18.0	10.5	17.0
196 001–230 000	400–46 000	11.0	16.0	10.0	15.0	9.0	14.0
	46 001–92 000	12.5	18.0	11.5	17.0	10.5	16.0
	92 001–161 000	14.0	20.0	12.5	19.0	11.5	18.0

Table 11-5—Outdoor bushing capacitance to ground

kV	A Rating	Range in pF	kV	A Rating	Range in pF	
15.0	600	160–180	115.0	800	250–450	
	1200	190–220		1200	250–430	
				1600	250–430	
23.0	400	200–450	138.0	800	250–450	
	600	280		1200	250–420	
	1200	190–450		1600	250–460	
	2000	280–650				
	3000	370–560				
34.5	4000	500–620	161.0	800	260–440	
				1200	260–440	
				1600	260–440	
	400	200–390		196.0	800	350–550
	600	150–220			1200	350–550
1200	170–390	1600	350–550			
46.0	2000	240–360	330.0	1600	530	
	3000	350–620				
	400	180–330		345.0	820–2000	
	600	150–280			BIL:1050	550
1200	170–330	1175	500			
69.0	2000	200–330	500.0	1300	450	
	400	180–270		800–2000		
	600	250		BIL:1425	500	
	1200	160–290		1550	500	
	2000	210–320		1675	520	

- a) Single-line diagram of the system showing all circuit elements and connection options
- b) Utility information, for each tie, at the connection point to the tie. This should include
 - 1) Impedances R , X_L , X_C , both positive and zero sequence representing minimum and maximum short-circuit duty conditions
 - 2) Maximum and minimum voltage limits
 - 3) Description of reclosing procedures and any contractual limitations, if any
- c) Individual power transformer data, such as rating; connections; no-load tap voltages; LTC voltages, if any; no-load saturation data; magnetizing current; positive and zero sequence leakage impedances; and neutral grounding details
- d) Capacitor data for each bank, connections, neutral grounding details, description of switching device and tuning reactors, if any
- e) Impedances of feeder cables or lines, that is, R , X_L , and X_C (both positive and zero sequence)
- f) Information about other power system elements, such as
 - 1) Surge arrester type, location and rating

Table 11-6—Synchronous machine constants

		Approximate reactances in percentage of machine kVA rating						Open-circuit time constant T_{do} (s)
		X_d	X'_d	X''_d	X_2	X_0	X_{eq}	
Turbine generators, two-pole	Average Range	115 95–145	15 12–21	9 7–14	11 9–16	3 1–8	75 60–100	4 3–7
Turbine generators, four-pole	Average Range	115 95–145	23 20–28	14 12–17	16 14–19	5 1.5–14	75 60–100	6 4–9
Waterwheel generator, without amortisseur windings	Average Range	100 60–145	35 20–45	30 17–40	50 30–65	7 4–25	65 40–100	5 2–10
Waterwheel generators, with amortisseur windings	Average Range	100 60–145	35 20–45	22 13–35	22 13–35	7 4–25	65 40–100	5 2–10
Synchronous condensers	Average Range	180 150–220	40 30–60	25 20–35	25 20–35	8 2–15	70 60–90	8 5–12
Salient-pole motors, high-speed	Average Range	80 65–90	25 15–35	18 10–25	19 10–25	5 2–15	50 40–60	2.5 1–4
Salient-pole motors, low-speed	Average Range	110 80–150	50 40–70	35 25–45	35 25–45	7 4–27	70 50–100	2.5 1–4

NOTE—With the exception of X''_d for turbine generators and the X_{eq} column, the above figures represent the approximate average and range of machine constants for both rated voltage and rated current conditions. The figures given for X''_d for turbine generators represent rated voltage values. The values given for X_{eq} are representative figures for machines of normal design operating at their full-load ratings.

- 2) Grounding resistors or reactors, rating and impedance of buffer reactors
- 3) Rating, subtransient and transient reactance of rotating machines, grounding details, etc.
- g) Operating modes and procedures

The material presented in the following pages is a compendium of parameter values, such as R_s , L_s , and C_s , for typical power system components that can be used in lieu of actual values. Most of the tabulated values were obtained from IEEE Std C37.011-1994. (This standard is in the process of being updated by the TRV Working Group of the IEEE Switchgear Committee.)

Table 11-7—Instrument transformer capacitance (primary winding to ground and to secondary with its terminals shorted and grounded)

Insulation class kV	Capacitance in pF		
	Potential transformers		Current transformers
	Line-to-line	Line-to-neutral	
15	260	—	—
25	250–440	270–800	180–260
34.5	310–440	270–900	160–250
46	350–430	300–970	170–220
69	360–440	340–1300	170–260
115	470–520	480–610	210–320
138	490–550	530–660	—
161	510–580	510–700	310–380
196	—	580–820	330–390
230	600–680	600–810	350–420
345	—	920	—

11.5 References

IEEE Std 446-1995, IEEE Recommended Practice for Emergency and Standby Power Systems for Industrial and Commercial Applications (IEEE Orange Book).

IEEE Std C37.011-1994, IEEE Application Guide for Transient Recovery Voltage for AC High-Voltage Circuit Breakers Rated on a Symmetrical Basis.

11.6 Bibliography

[B1] Dommel, H. W., “*Electro-Magnetic Transients Program (EMTP) Manual*,” Bonneville Power Administration, Portland, 1984.

[B2] Fich, S., *Transient Analysis in Electrical Engineering*. New York: Prentice-Hall, Inc., 1971.

[B3] Gill, J. D., “Transfer of motor loads between out-of-phase sources,” *IEEE Transactions on Industry Applications*, vol. IA-15, no. 4, pp. 376–381, Jul./Aug. 1979.

Table 1-8—Generator armature capacitance to ground

Generator size in MVA	Total three-phase winding capacitance to ground in μF
(1) Steam turbine driven: Conventionally cooled (two-pole 3600 r/min) 15 up to 30 30 up to 50 50 up to 70 70 up to 225 225 up to 275	0.17–0.36 0.22–0.44 0.27–0.52 0.34–0.87 1.49
(four-pole 1800 r/min) 125 up to 225	0.04–1.41
Conductor cooled: gas (two-pole 3600 r/min) 100 up to 300	0.33–0.47
Conductor cooled: liquid (two-pole 3600 r/min) 190 up to 300 300 up to 850	0.27–0.67 0.49–0.68
(four-pole 1800 r/min) 250 up to 300 300 up to 850 Above 850	0.37–0.38 0.71–0.94 1.47
(2) Hydro driven: 720 to 360 r/min 10 to 30 MVA	0.26–0.53
225 to 85 r/min 25 to 100 MVA	0.90–1.64
NOTE—There is no direct correlation between generator MVA size, size limit, and capacitance limits. For instance, a 50 MVA generator may have an armature capacitance to ground anywhere from 0.27 to 0.52 μF , depending on machine design.	

[B4] Goldman, S., *Laplace Transform Theory and Electrical Transients*. New York: Dover Publications, 1966.

[B5] Greenwood, A., *Electrical Transients in Power Systems*, New York: John Wiley & Sons, Inc., 1971.

[B6] Mazur, A., Kerszenbaum, I., and Frank, J., “Maximum insulation stress under transient voltages in the HV barrel-type winding of distribution and power transformers,” *IEEE Transactions on Industry Applications*, vol. IA-24, no. 3, May/June 1988.

[B7] Miller, R., *Algebraic Transient Analysis*. San Francisco: Reinhart Press, 1971.

Table 1-9—Phase bus capacitance

Isolated phase bus			Segregated phase bus
A Rating	15 kV class 110 kV BIL (pF/ft)	23 kV class 150 kV BIL (pF/ft)	15 kV class 110 kV BIL (pF/ft)
1200	8.9–14.3	8.0–12.4	10.0
2000	10.2–14.3	9.0–12.4	10.0–10.2
2500	10.2–14.3	9.0–12.4	
3000	10.2–14.3	9.0–12.4	10.0–10.2
3500	10.2–14.3	9.0–12.4	
4000	14.0–14.3	12.4–13.5	10.0–12.6
4500	14.0–14.3	12.7–13.5	
5000	14.0–19.0	12.7–15.8	12.5–14.9
5500	14.0–19.0	12.7–15.8	
6000	14.0–19.0	13.5–15.8	15.0–17.1
6500	14.0–19.0	13.5–15.8	
7000	17.3–22.6	14.4–17.6	17.1
7500	17.3–22.6	14.4–17.6	
8000	21.7	17.6	—
9000	21.7	18.1	
10 000	21.7	18.1	—
11 000	23.7	20.5	
12 000	23.7	20.5	—

Table 1-10—Typical values of inductance between capacitor banks

Rated maximum voltage (kV)	Inductance per phase of bus (μ H/ft)	Typical inductance between banks (μ H)
15.5 and below	0.214	10–20
38	0.238	15–39
48.3	0.256	20–40
72.5	0.256	25–50
121	0.261	35–70
145	0.261	40–80
169	0.268	60–120

Table 1-11—Typical transmission line characteristics 69 kV–230 kV

Nominal voltage (kV) (line-to-line)	69	115	138	161	230
X_1 (Ω /mi)	0.783	0.759	0.771	0.771	0.785
R_1 (Ω /mi)	0.340	0.224	0.194	0.137	0.107
$ Z_1 $ (Ω /mi)	0.854	0.792	0.795	0.783	0.792
X_1/R_1	2.30	3.40	3.98	5.64	7.36
X_0	2.37	2.30	2.48	2.22	2.35
R_0	1.22	0.755	0.586	0.591	0.576
$ Z_0 $	2.67	2.42	2.55	2.30	2.42
X_0/R_0	1.95	3.05	4.23	3.76	4.08
X_0/X_1	3.03	3.03	03.22	2.88	2.99
X_1 ($1/B_1$) ($M\Omega$ /mi)	0.184	0.178	0.183	0.174	0.177
B_1 (μ Mho/mi)	5.43	5.63	5.46	5.73	5.63
B_0 (Ω /Mi)	3.38	3.09	3.41	3.63	3.33
Surge impedance Positive sequence (Ω)	397	375	381	370	375
Surge impedance Zero sequence (Ω)	889	885	865	795	852
Surge impedance Loading (SIL) (MVA)	0.216	35.3	49.9	70.1	141
Charging current (A/mi)	0.216	0.373	0.435	0.533	0.748
Charging MVA (MVA/mi)	0.0258	0.0774	0.104	0.149	0.298
Line current at SIL (A)	100	177	209	252	354
I^2R loss at SIL (kW/mi)	3.43	7.00	8.45	8.60	13.4
Equivalent spacing (ft)	13.8	13.8	15.1	19.8	24.9

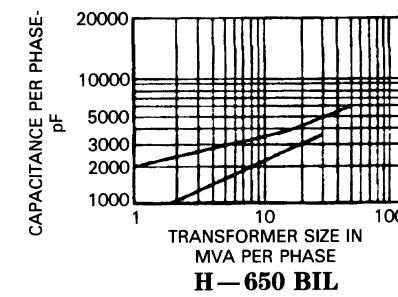
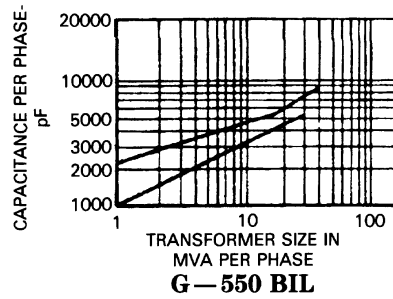
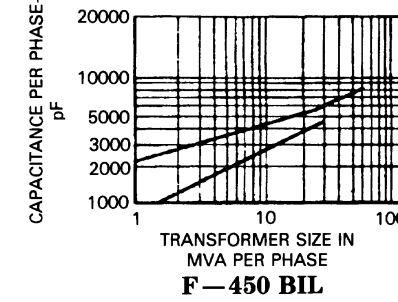
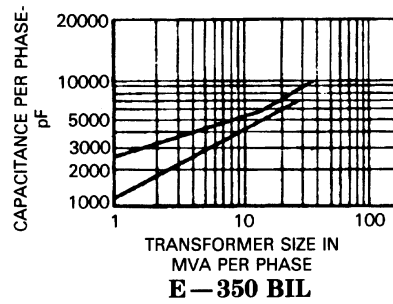
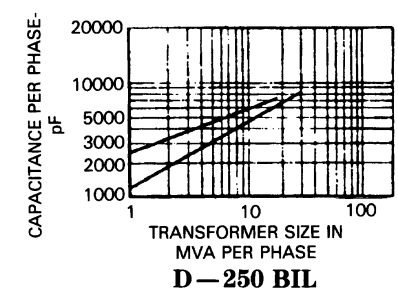
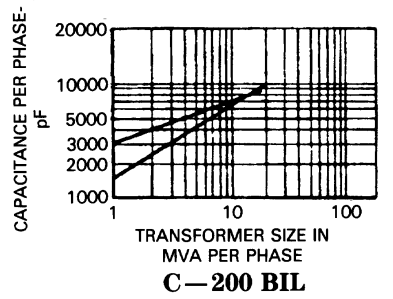
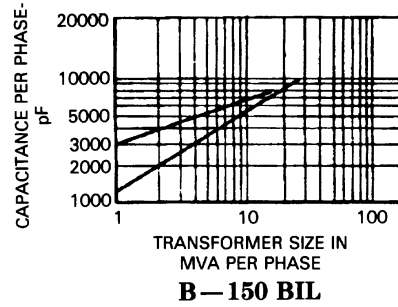
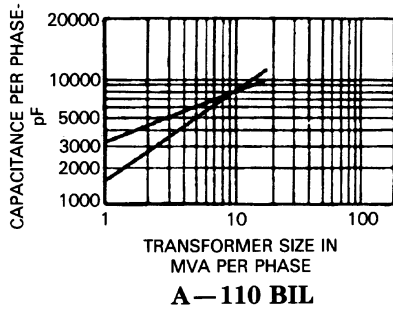
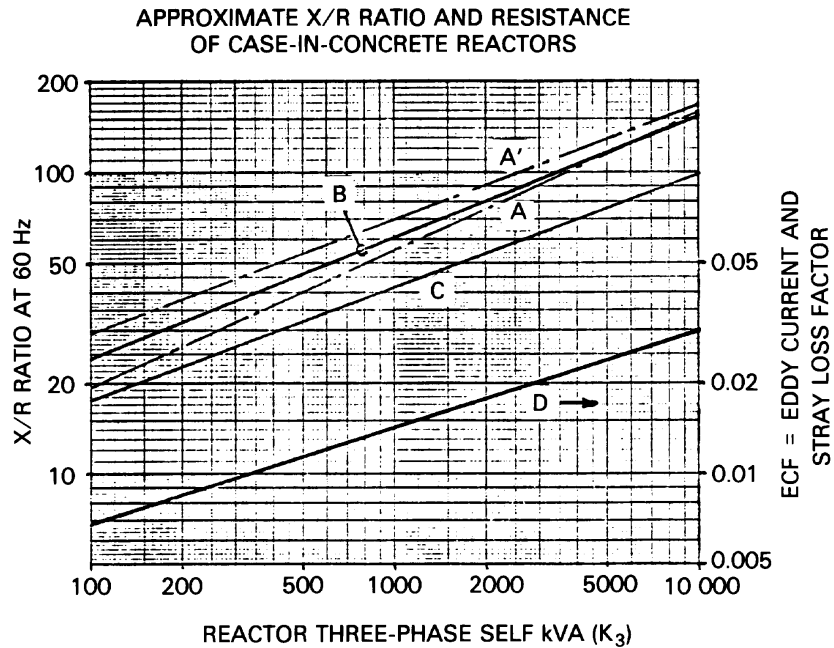

Figure 1-34—Typical values of transformer winding capacitance to ground



$$3 \times \text{SELF kVA OF SINGLE-PHASE REACTOR} = 3 \times I^2 X \times 10^{-3} = K_3$$

A — Nominal X/R ratio for aluminum conductor reactor = $231K_3^{0.461}$

A' — “High Q” X/R ratio for aluminum conductor reactor = $5.09K_3^{0.379}$

B — Maximum X/R ratio for copper conductor reactor = $3.88K_3^{0.398}$

C — Nominal 60 Hz X/R ratio for tuning reactor = $3.07K_3^{0.377}$

D — Eddy current and stray loss factor for tuning reactor

$$= (1.16 \times 10^{-3}) (K_3^{0.353});$$

$$R_n = \text{Resistance at } fn \text{ (any frequency)} = R_{60}(1+n^2\text{ECF}) / (1+\text{ECF}),$$

$$\text{where } R_{60} = 60 \text{ Hz resistance and } n = fn/60$$

Figure 1-35—Typical X/R ratio and resistance of reactors

[B8] Peterson, H. A., *Transients in Power Systems*. New York: General Electric Company, 1951.

[B9] “Transient Network Analyzer Manual,” General Electric Company, New York, 1978.

[B10] Wadha, C. L., *Electrical Power Systems*. New Delhi: Wiley Eastner Limited, 1983.

[B11] White, E. L., Surge-Transference Characteristics of Generator/Transformer Installations, *Proceedings of the IEE*, vol. 116, p. 575, 1969.

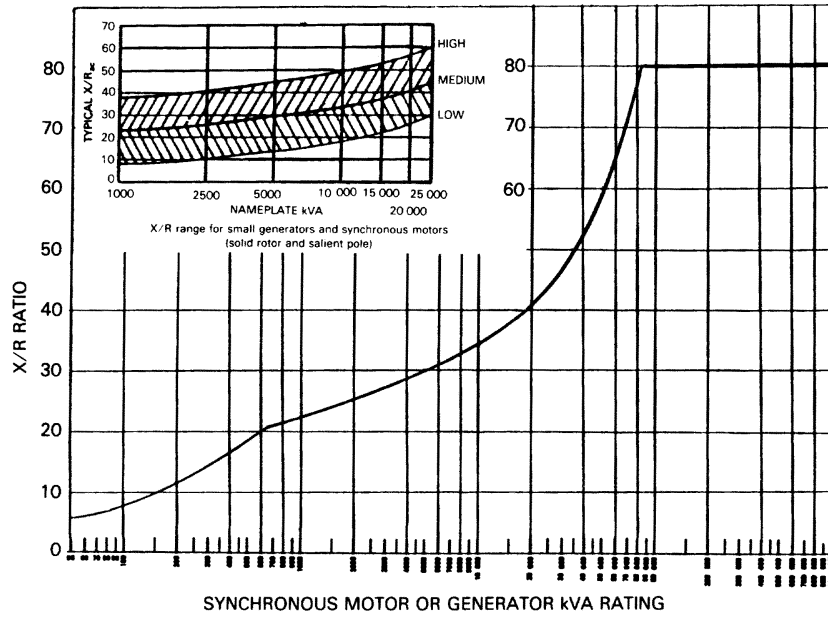

Figure 1-36—Typical X/R ratio of generators

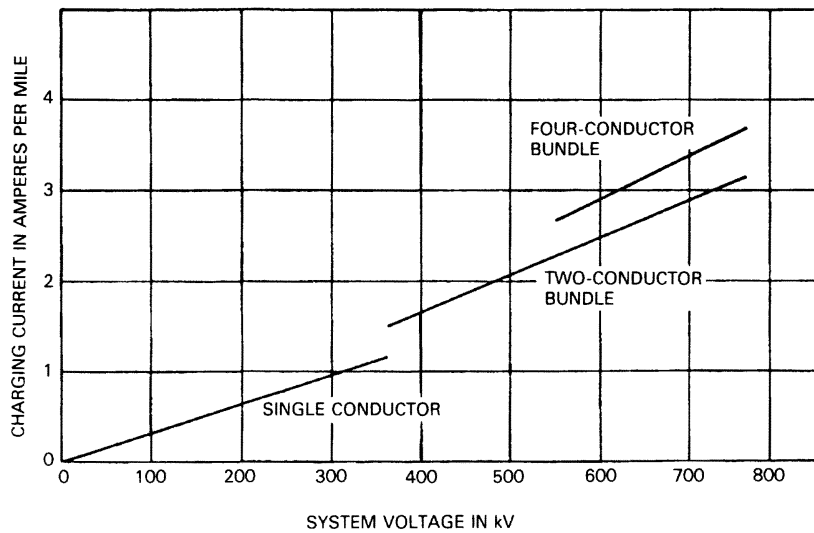

Figure 1-37—Typical charging current for cable

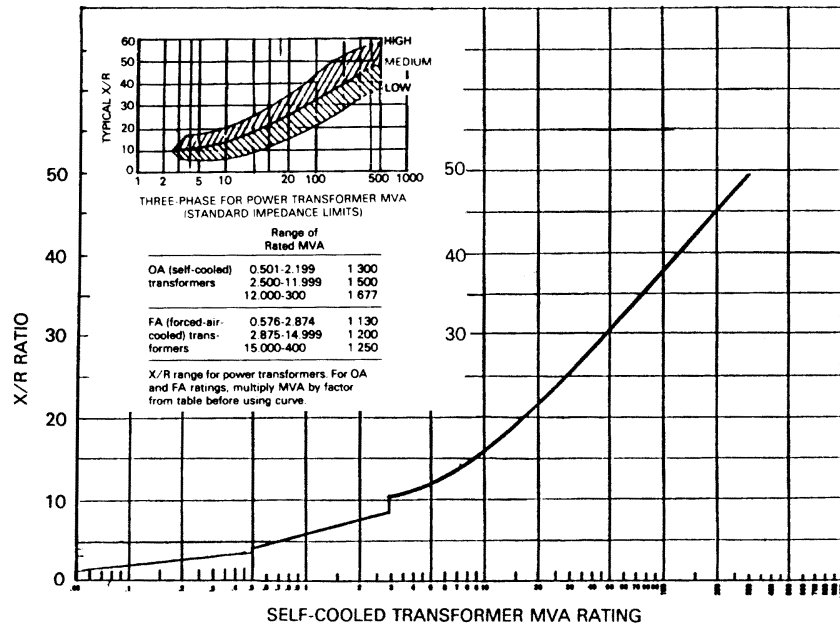

Figure 1-38—Typical X/R ratio of transformers

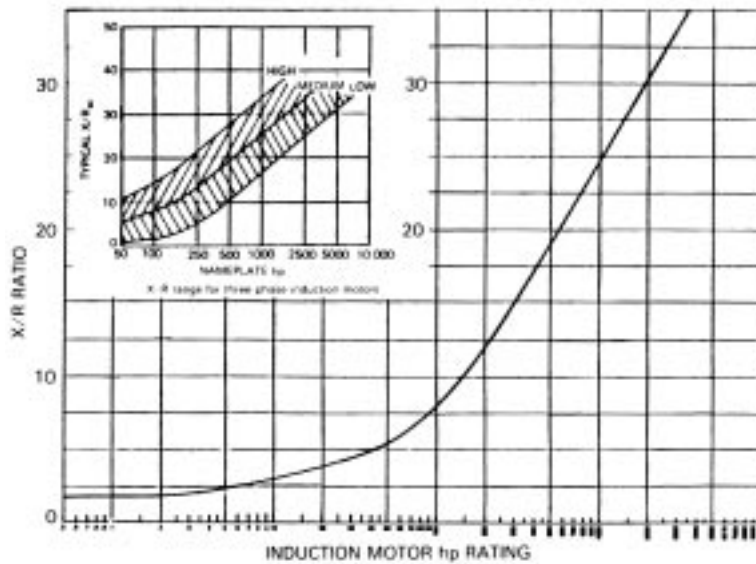

Figure 1-39—Typical X/R ratio of induction motors

Chapter 12

Reliability studies

12.1 Introduction

An important aspect of power system design involves consideration of service reliability requirements of loads to be supplied and service reliability provided by any proposed system. System reliability assessment and evaluation methods based on probability theory allow the reliability of a proposed system to be assessed quantitatively. Such methods permit consistent, defensible, and unbiased assessments of system reliability that are not otherwise defensible, and that are not otherwise possible.

Quantitative reliability evaluation methods permit reliability indexes for any electric power system computed from knowledge of the reliability performance of the constituent components of the system. Thus, alternative system designs can be studied to evaluate the impact on service reliability and cost of changes in component reliability, system configuration, protection and switching scheme, and system operating policy including maintenance practice. A detailed treatment of reliability evaluation methods is given in IEEE Std 493-1997.¹

12.2 Definitions

The definitions presented here provide much of the required nomenclature for discussions of power system reliability.

12.2.1 availability: A term that applies either to the performance of individual components or to a system. Availability is the long-term average fraction of time that a component or system is in service satisfactorily performing its intended function. An alternative and equivalent definition for availability is the steady-state probability that a component or system is in service.

12.2.2 component: A piece of equipment, a line or circuit, or a section of a line or circuit, or a group of items that is viewed as an entity for purposes of reliability evaluation.

12.2.3 expected interruption duration: The expected, or average, duration of a single load interruption event.

12.2.4 exposure time: The time during which a component is performing its intended function and is subject to failure. Usually expressed in years.

12.2.5 failure: Any trouble with a power system component that causes any of the following to occur:

¹Information on references can be found in 12.6.

- Partial or complete shutdown, or below-standard plant operation
- Unacceptable performance of user's equipment
- Operation of the electrical protective relaying or emergency operation of the plant electrical system
- De-energization of any electric circuit or equipment

A failure on a public utility supply system can cause the user to have either of the following:

- A power interruption or loss of service
- A deviation from normal voltage or frequency outside the normal utility profile

A failure of an in-plant component causes a forced outage of the component, that is, the component is unable to perform its intended function until repaired or replaced. *Syn:* **forced outage**.

12.2.6 failure rate (forced outage rate): The mean number of failures of a component per unit of exposure time. Usually, expressed in failures per year.

12.2.7 forced outage: *See:* **failure**.

12.2.8 forced outage duration: *See:* **repair time**.

12.2.9 forced unavailability: The long-term average fraction of time that a component or system is out of service due to a forced outage (failure).

12.2.10 interruption: The loss of electric power supply to one or more loads.

12.2.11 interruption frequency: The expected (average) number of power interruptions to a load per unit time, usually expressed as interruptions per year.

12.2.12 outage: The state of a component or system when it is not available to properly perform its intended function due to an event directly associated with that component or system.

12.2.13 repair time: The repair time of a failed component or the duration of a failure is the clock time from the occurrence of the failure to the time when the component is restored to service, either by repair of the failed component or by substitution of a spare component for the failed component. It includes time for diagnosing the trouble, locating the failed component, waiting for parts, repairing or replacing, testing, and restoring the component to service. It does not include the time required to restore service to a load by putting alternate circuits into operation. *Syn:* **forced outage duration**.

12.2.14 scheduled outage: An outage that results when a component is deliberately taken out of service at a selected time, usually for purposes of construction, maintenance, or repair.

12.2.15 scheduled outage duration: The period from the initiation of a scheduled outage until construction, preventive maintenance, or repair work is completed and the affected component is made available to perform its intended function.

12.2.16 scheduled outage rate: The mean number of scheduled outages of a component per unit exposure time.

12.2.17 switching time: The period from the time a switching operation is required due to a component failure until that switching operation is completed. Switching operations include such operations as throwover to an alternate circuit, opening or closing a sectionalizing switch or circuit breaker, reclosing a circuit breaker following a tripout from a temporary fault, etc.

12.2.18 system: A group of components connected or associated in a fixed configuration to perform a specified function of distributing power.

12.2.19 unavailability: The long-term average fraction of time that a component or system is out of service due to failures or scheduled outages. An alternative definition is the steady-state probability that a component or system is out of service. Mathematically, unavailability = (1 – availability).

12.3 System reliability indexes

The basic system reliability indexes that have proven most useful and meaningful in power distribution system design are as follows:

- Load interruption frequency
- Expected duration of load interruption events

These indexes can be readily computed using the methods in IEEE Std 493-1997. The two basic indexes of interruption frequency and expected interruption duration can be used to compute other indexes that are also useful:

- Total expected (average) interruption time per year (or other time period)
- System availability or unavailability as measured at the load supply point in question
- Expected, demanded, but unsupplied, energy per year

Note that the disruptive effect of power interruption is often nonlinearly related to the duration of the interruption. Thus, it is often desirable to compute not only an overall interruption frequency but also frequencies of interruptions categorized by the appropriate durations.

12.4 Data needed for system reliability evaluations

The data needed for quantitative evaluations of system reliability depend to some extent on the nature of the system being studied and the detail of the study. In general, however, data on the performance of individual components together with the times required to perform various switching operations are required.

System component data generally required are summarized as follows:

- Failure rates (forced outage rates) associated with different modes of component failure
- Expected (average) time to repair or replace failed component
- Scheduled (maintenance) outage rate of component
- Expected (average) duration of a scheduled outage event

If possible, component data should be based on historical performance of components in the same environment as those in the proposed system being studied. The reliability surveys conducted by the Power Systems Reliability Subcommittee provide a source of component data when such specific data is not available. This data and the data from later surveys are summarized in Chapter 3 of IEEE Std 493-1997.

Switching time data generally required includes the following:

- Expected times to open and close a circuit breaker
- Expected times to open and close a disconnect or throwover switch
- Expected time to replace a fuse link
- Expected times to perform such emergency operations as cutting in clear, installing jumpers, etc.

Switching times should be estimated for the system being studied based on experience, engineering judgment, and anticipated operating practices.

12.5 Method for system reliability evaluation

The general method for system reliability evaluation that is recommended and presented here has evolved over a number of years. The method, referred to as the “minimal cut-set method,” is believed to be particularly well suited to the study and analysis of electric power distribution systems as found in industrial plants and commercial buildings. The method is systematic and straightforward and lends itself to either manual or computer computation. An important feature of the method is that system weak points can be readily identified, both numerically and non-numerically, thereby focusing design attention on those sections of the system that contribute most to service unreliability.

The procedure for system reliability evaluation is outlined as follows:

- a) Assess the service reliability requirements of the loads and processes that are to be supplied and determine appropriate service interruption definition or definitions.
- b) Perform a failure modes and effects analysis (FMEA), which consists of identifying and listing those component failures and combinations of component failures that result in service interruptions and that constitute minimal cut-sets of the system.
- c) Compute interruption frequency contribution, expected interruption duration, and the probability of each of the minimal cut-sets of the system.
- d) Combine the results of step c) to produce system reliability indexes.

These steps will be discussed in more detail in the sections that follow.

12.5.1 Service interruption definition

The first step in any electric power system reliability study should be a careful assessment of the power supply quality (e.g., sags, surges, harmonics, etc.) and continuity required by the loads that are to be served. This assessment should be summarized and expressed in a service interruption definition that can be used in the succeeding steps of the reliability evaluation procedure. The interruption definition specifies, in general, the reduced voltage level (voltage dip) together with the minimum duration of such reduced voltage period that results in substantial degradation or complete loss of function of the load or process being served. Frequently, reliability studies are conducted on a continuity basis, in which case, interruption definitions reduce to a minimum duration specification with voltage assumed to be zero during the interruption.

12.5.2 Failure modes and effects analysis (FMEA)

The FMEA for power distribution systems amounts to the determination and listing of those component outage events or combinations of component outages that result in an interruption of service at the load point being studied according to the interruption definition that has been adopted. This analysis must be made in consideration of the different types and modes of outages that components may exhibit and the reaction of the system's protection scheme to these events. Component outages are categorized as follows:

- Forced outages or failures
- Scheduled or maintenance outages
- Overload outages

Forced outages or failures are either permanent forced outages or transient forced outages. Permanent forced outages require repair or replacement of the failed component before it can be restored to service; transient forced outages imply no permanent damage to the component, thus permitting its restoration to service by a simple reclosing or refusing operation. Additionally, component failures can be categorized by physical mode or type of failure. This type of failure categorization is important for circuit breakers and other switching devices where the following failure modes are possible:

- Faulted, must be cleared by backup devices
- Fails to trip when required

- Trips falsely
- Fails to reclose when required

Each will produce a varying impact on system performance.

The primary result of the FMEA as far as quantitative reliability evaluation is concerned is the list of minimal cut-sets it produces. A minimal cut-set is defined to be a set of components which, if removed from the system, results in loss of continuity to the load point being investigated and does not contain as a subset any set of components that is itself a cut-set of the system. In the present context, the components in a cut-set are just those components whose overlapping outage results in an interruption according to the interruption definition adopted.

An important nonquantitative benefit of FMEA is the thorough and systematic thought process and investigation it requires. Often weak points in system design will be identified before any quantitative reliability indexes are computed. Thus, the FMEA is a useful reliability design tool even in the absence of the data needed for quantitative evaluation.

12.5.3 Computation of quantitative reliability indexes

Computation of reliability indexes can proceed once the minimal cut-sets of the system have been found. The first step is to compute the frequency, expected duration, and expected down-time per year of each minimal cut-set. Note that expected down-time per year is the product of the frequency expressed in terms of events per year and the expected duration. If the expected duration is expressed in years, the expected down-time will have the units of years per year and can be regarded as the relative proportion of time or probability the system is down due to the minimal cut-set in question. More commonly, expected duration is expressed in hours and the expected down-time has the units of hours per year.

Approximate expressions for frequency and expected duration of the most commonly considered interruption events associated with first-, second-, and third-order minimal cut-sets are given in Table 12-1. Note that expressions for the calculation of interruption frequencies and durations are for forced outages (failures) only. A detailed treatment of expressions for the calculation of interruption frequency and duration considering forced outages as well as maintenance outages, switching after faults to restore service, and incomplete redundancy of parallel facilities is given in IEEE Std 493-1997.

12.6 References

This chapter shall be used in conjunction with the following publication:

IEEE Std 493-1997, IEEE Recommended Practice for the Design of Reliable Industrial and Commercial Power Systems (IEEE Gold Book).

Table 2-1—Frequency and expected duration expressions for interruptions associated with forced outages only

First order minimum cut-set	Second-order minimal cut-set	Third-order minimal cut-set
$f_{cs} = \lambda_i$ $r_{cs} = r_i$	$f_{cs} = \lambda_i \lambda_j (r_i + r_j)$ $r_{cs} = r_i r_j (r_i + r_j)$	$f_{cs} = \lambda_i \lambda_j \lambda_k (r_i r_j + r_i r_k + r_j r_k)$ $r_{cs} = r_i r_j r_k / (r_i r_j + r_i r_k + r_j r_k)$
<p>Symbols:</p> <p>f_{cs} = frequency of cut-set event r_{cs} = expected duration of cut-set event λ_i = forced outage rate of <i>i</i>th component r_i = expected repair or replacement time of <i>i</i>th component</p>		
<p>NOTES</p> <p>1—The time units of <i>r</i> and λ in expressions for f_{cs} must be the same. Once frequencies and expected durations have been computed for each minimal cut-set, system reliability indexes at the load point in question are given by the following:</p> <p>f_s = interruption frequency $= \sum f_{cs_i}$ minimum cut-sets</p> <p>r_s = expected interruption duration $= \sum f_{cs_i} r_{cs_i} / f_s$ minimum cut-sets</p> <p>$f_s r_s$ = total interruption time per time period</p> <p>2—These are approximate formulas and should only be used when every $\lambda_i r_i, \lambda_j r_j, \lambda_k r_k$ (dimensionless) is less than 0.01.</p>		

Chapter 13

Cable ampacity studies

13.1 Introduction

The cables that network a power system together form the backbone of the system. It is only logical, therefore, that any complete analysis of a power system should include an analysis of its cable ampacities. This analysis is complicated since the ampacity of a conductor varies with the actual conditions of use. Ampacity is defined as “the current in amperes a conductor can carry continuously under the conditions of use (conditions of the surrounding medium in which the cables are installed) without exceeding its temperature rating.” Therefore, a cable ampacity study is the calculation of the temperature rise of the conductors in a cable system under steady-state conditions. The purpose of this chapter is to acquaint the reader with the use of computer software systems in the solution of cable ampacity problems with emphasis on underground installations.

The ampacity of a conductor depends on a number of factors. Prominent among these factors and of much concern to the designers of electrical distribution systems are the following:

- a) Ambient temperature
- b) Thermal characteristics of the surrounding medium
- c) Heat generated by the conductor due to its own losses
- d) Heat generated by adjacent conductors

To account for the various items that affect ampacities of cables, the 1975 edition of the National Electrical Code[®] (NEC[®]) (see NFPA 70-1996¹) accepted, for the first time, the Neher-McGrath method (Neher and McGrath [B10]²) of determining the ampacities of conductors. Since then, the NEC has added new ampacity tables to account for some limited conditions of use. As an alternative to the ampacity tables, Section 310-15 (b) of NFPA 70-1996 permits, under engineering supervision, the use of an ampacity equation for determining ampacities. A discussion of this evolution and the origin of NEC Tables 310-16 through 310-19 is provided in Knutson and Miles [B1]. This equation is based on the Neher-McGrath method, which is the basis for the calculating procedures discussed in this chapter.

In subsequent paragraphs, various items that affect cable ampacities are discussed and quantified with the help of ampacity adjustment factor tables and actual computer runs. The computer program from which the ampacity adjustment factors were generated is based on the Neher-McGrath method of calculation and has been corroborated by a second, independently developed computer program of like kind. Under some specific and limited conditions, the ampacity adjustment tables were compared and verified with the NEC ampacity tables, including Appendix B of the NEC. Note that the tables provided here generally cover broader conditions of use with greater resolution than the NEC tables.

¹Information on references can be found in 13.7.

²The numbers in brackets correspond to those of the bibliography in 13.8.

Since the ampacity adjustment tables have been developed for some specific conditions, they cannot be applied for all cases. In general, these tables can be used to size the cables in the initial stages of a design and to closely approximate ampacities. These preliminary cable sizes can then be used as the basis for a more rigorous computer analysis to determine actual conductor temperatures and to finalize the design.

13.2 Heat flow analysis

When designing a power distribution system, the cable ampacity is of primary concern. Once the size and location of electrical loads are determined, an adequate distribution system must be designed. The total number of required circuits, their sizes, and the method of routing are significant elements in the design problem. But in addition, accurate cable sizing becomes especially critical to ensure that the cables are adequate to carry the required load without being subjected to temperatures that exceed their temperature ratings.

As an electrical current flows through a cable, it generates heat. The type of cable and how it is connected and installed determines how many components of heat generation are present, e.g., I^2R losses, sheath losses, etc. The heat flows from these sources through a series of thermal resistances to the surrounding environment. The operating temperature that the cable ultimately reaches is directly related to the amount of heat generated and the net effective value of the thermal resistance through which it flows.

A detailed discussion of all the heat transfer complexities involved is beyond the scope of this subclause. However, the heat transfer process will be covered briefly in order to establish a basic background from which the discussion to follow can proceed.

The calculation of the temperature rise of cable systems involves the application of a series of thermal equivalents of Ohm's and Kirchoff's laws to a relatively simple thermal circuit, as is illustrated in Figure 13-1. This circuit includes a number of parallel paths with heat entering at several points. Under conditions of equilibrium, the conductor temperature will be determined by the temperature differential created across a series of thermal resistances as the heat flows to the ambient temperature $T'_c = T'_a + \Delta T$.

To understand the basic calculation procedure used in cable ampacity programs, consider the fundamental equation for the ampacity of a cable in an underground duct.

$$I = \left[\frac{T'_c - (T'_a + \Delta T_d + \Delta T_{int})}{(R_{ac})(R'_{ca})} \right]^{1/2} \text{ kA} \quad (13-1)$$

This equation follows the Neher-McGrath method where

- T'_c is the allowable conductor temperature ($^{\circ}\text{C}$),
- T'_a is the soil ambient temperature ($^{\circ}\text{C}$),
- ΔT_d is the temperature rise of conductor due to dielectric heating ($^{\circ}\text{C}$),
- ΔT_{int} is the temperature rise of conductor due to interference heating from cables in other ducts ($^{\circ}\text{C}$). (Note that since the temperature rise, due to another conductor,

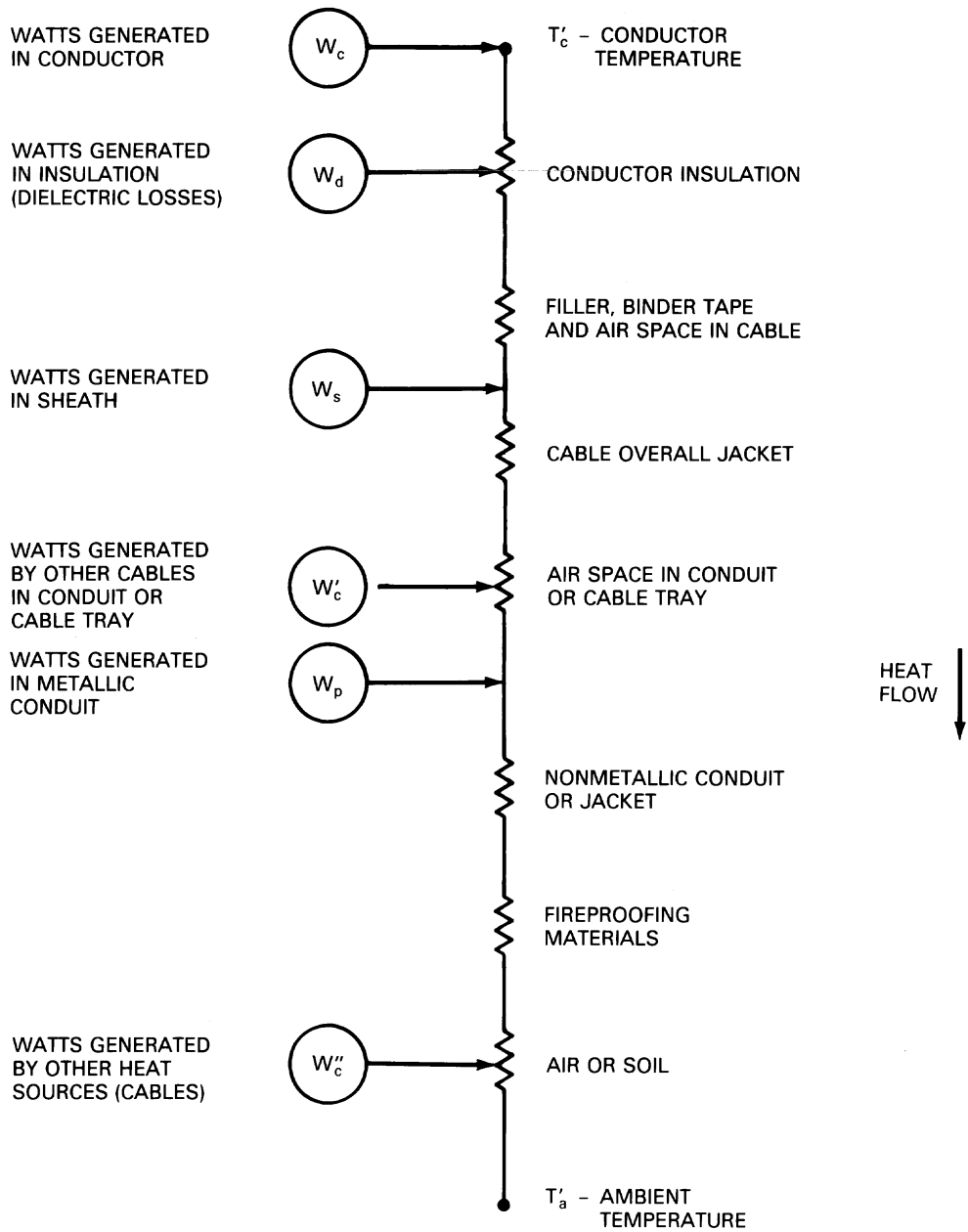

Figure 13-1—A generalized model for heat flow from heat sources in a cable system to ambient temperature through a series of thermal resistances

depends on the current through it, simultaneous solutions of ampacity equations are required.)

- R_{ac} is the electrical alternating current resistance of conductor including skin, proximity, and temperature effects ($\mu\Omega/\text{ft}$),
- R'_{ca} is the effective total thermal resistance from conductor to ambient soil adjusted to include effects of load factor, shield/sheath losses, metallic conduit losses, and the effect of multiple conductors in the same duct (thermal- Ω/ft , $^{\circ}\text{C-ft/W}$).

Note that all effects that produce a conductor temperature rise except the conductor loss (I^2R_{ac}) have been treated as adjustments to the basic thermal system. Fundamentally, the difference between two temperatures (e.g., $T'_c - T'_a$) divided by a separating thermal resistance equals the heat flow in watts (or W/ft of conductor). The similarity of the procedure used in the cable ampacity program to that used with the traditional approach is apparent if both sides of the ampacity equation are squared and then multiplied by R_{ac} . The result is as follows:

$$I^2R_{ac} = \frac{T'_c - (T'_a + \Delta T_d + \Delta T_{int})}{(R'_{ca})} \text{ W/ft} \quad (13-2)$$

Although it is not necessary to understand these heat transfer concepts in order to use cable ampacity programs, such knowledge may be helpful for understanding how physical parameters affect ampacity. Observation of the ampacity equation shows how lower ampacities are inherent with the following:

- Lower conductor operating temperatures
- Higher soil ambient temperatures
- Smaller conductors (higher R_{ac})
- Higher thermal resistivities of earth, concrete, insulation, duct, etc. (higher R'_{ca})
- Deeper burial depths (higher R'_{ca})
- Closer cable spacing (higher ΔT_{int})
- Cables located in inner, rather than outer, ducts (higher ΔT_{int})

Other factors that decrease ampacity and whose relationship to the ampacity equation is not readily apparent include the following:

- Higher load factor (higher R'_{ca})
- Higher voltage (higher ΔT_d)
- Higher insulation SIC and power factor (higher ΔT_d)
- Lower shield/sheath electrical resistance (higher R'_{ca})

13.3 Application of computer program

The calculations used in cable ampacity programs are normally based on the Neher-McGrath method. In computing cable ampacities in duct banks, only power cables need to be considered, since control cables, carrying very little current, contribute very little to the overall temperature rise. Cable ampacity programs deal only with the temperature-limited,

current-carrying capacity of cables. Voltage drop, future load growth, and short-circuit capability are also important factors that should be considered when selecting cables.

The calculation of cable ampacity in underground installations is a very complicated procedure requiring the evaluation of a multitude of subtle effects. In order to make the calculations possible for a wide variety of cases, certain assumptions are made. Most of the assumptions are developed by Neher and McGrath in [B10] and are widely accepted. Some programs may make other assumptions that should be understood.

The basic steps in applying cable ampacity programs follow. It is important to follow methodical procedures in order to obtain good results with minimum effort.

- a) The first step in designing an underground cable installation is to establish which circuits are to be routed through the duct bank. Consideration should be given to present circuits as well as to circuits that may be added in the future. Only power cables need to be included as current-carrying conductors in analysis; but space allowances must be made for spare ducts or for control and instrumentation circuits.
- b) The duct bank should be designed with consideration given to the circuits contained, the space available for the bank, cable separation criteria, and factors that affect ampacity. For example, cables buried deeply or surrounded by other power cables often have greatly reduced ampacity. It should be decided if ducts will be directly buried or encased in concrete. The size(s) and type(s) of duct to be used should be determined. Finally, a sketch of the duct bank should be prepared with burial depth and spacing of ducts clearly shown. Physical data on the duct installation should be compiled, including thermal resistivity of the soil, ambient temperature of the soil, and thermal resistivity of the concrete. Note that soil thermal resistivity and temperature at some locations (e.g., desert) may be much greater than the typical values often used.
- c) Complete data on all power cables used in the installation must be assembled. Some data may be taken from standard tables; but certain data should be based on manufacturer's specifications. Conductor size, conductor material, operating voltage, type of shield or sheath, temperature rating, insulation type, and jacket type are especially important.
- d) An initial cable placement layout should be designed, based on anticipated loads and load factors. Circuits with high currents and load factors (ratio of average to peak load over a given load cycle) should be placed in outside ducts near the top of the bank to eliminate the need for larger conductors due to unnecessarily reduced ampacity. Frequently, a good compromise between best use of duct space and highest ampacity is achieved by installing each three-phase circuit in a separate duct. However, nonshielded single-conductor cables may have a higher ampacity with each phase conductor in a separate nonmetallic duct. If the load factor cannot be evaluated readily, a conservative value of 1.0 may be entered, which implies that the circuit always operates at peak load.
- e) The manual method presented in this chapter can be used to initially size the cables based on the ambient temperature, soil thermal resistivity, and grouping of the cables.
- f) Once the initial design is established and all necessary data have been collected, the user should enter the program data interactively or prepare an input data file for a

batch program. Normally, the data should be prepared for standard ampacity calculation, using the worst-case conditions. If actual load currents are known, these may be entered to find the temperatures of cables within each duct. Temperature calculations are especially useful if some circuits are lightly loaded, while others carry heavy loads that push ampacity limits. If the lightly loaded circuits were to operate at rated temperature, as the ampacity calculation assumes, the load capability of the heavily loaded circuits would be reduced. Temperature calculations may also be used as a rough indicator of the reserve capacity of each duct.

- g) After a program is run, the user should carefully analyze the results to verify that design currents are less than ampacities (if an ampacity calculation is performed), or that actual temperatures are less than rated temperatures (if a temperature calculation is performed). If the initial design is shown to be inadequate, various corrective measures should be considered. These include increasing conductor sizes, modifying cable locations, and changing the physical design of the bank. The effects of various parameters may be analyzed by repeating these steps until a satisfactory overall design is achieved.
- h) The results of such an analysis should be documented and permanently archived for use in properly controlling and/or analyzing future changes in duct bank usage (i.e., installation of cables in spare ducts).

13.4 Ampacity adjustment factors

The ampacity values stated (specified) by the cable manufacturer and/or other authoritative sources, such as the NEC and IEEE Std 835-1994, are usually based on some very specific conditions relative to the cable's immediate surrounding environment. The following are examples of some specific conditions:

- Installation under an isolated condition
- Installation of groups of three or six circuits
- Soil thermal resistivity (RHO) of 90 °C-cm/W
- Ambient temperature of 20 °C or 40 °C

In practice, the surrounding medium or environment in which cables are to be installed rarely matches those conditions under which the stated ampacities apply. The differences can be thought of as an intermediate medium (requiring adjustment factors for conditions of use) inserted between the base conditions (an environment at which the base ampacity is specified by the manufacturer or other authoritative sources) and the actual conditions of use. This process is presented pictorially in Figure 13-2. It illustrates that the nature of the practical problem is to adjust the specified (base) ampacities of the cables by an adjustment factor to account for the effects of the various intermediate elements or conditions of use.

A simple manual method of determining cable ampacities is presented here to illustrate the concept of cable derating and to present the different factors that have a direct effect on the operating temperatures of the conductors.

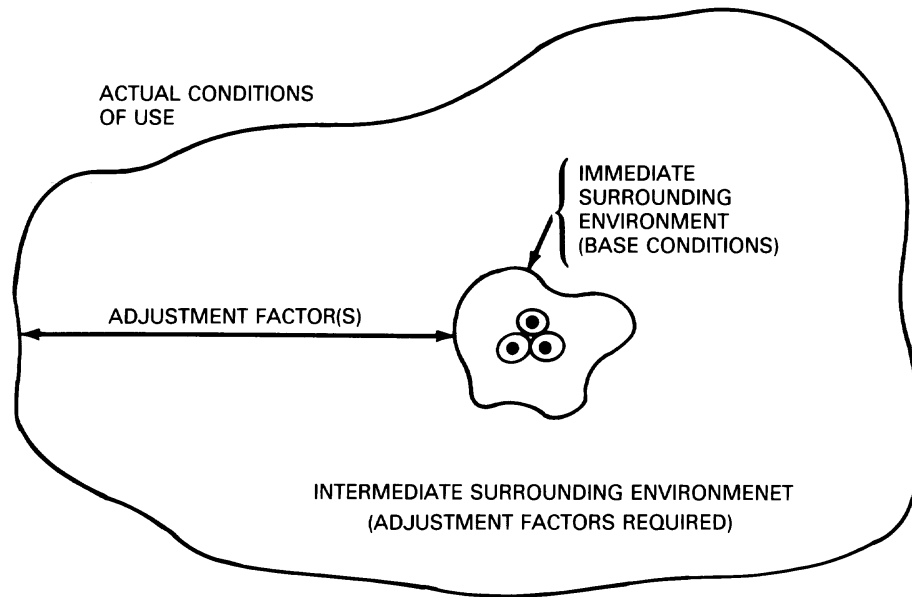

Figure 13-2—Simplified illustration of the heat transfer model used to determine the cable ampacity (3-1/C cables shown)

This method is based on the concept of an adjustment (derating) factor applied against a base ampacity to provide the allowable cable ampacity.

$$I' = FI \quad (13-3)$$

where

- I' is the allowable ampacity under the actual installation conditions,
- F is the overall cable ampacity adjustment factor,
- I is the base ampacity, i.e., the ampacity specified by the manufacturers or other authoritative sources, such as the ICEA. For example, the ampacity of a cable that is installed in an underground conduit under isolated conditions with an ambient temperature of 20 °C and soil thermal resistivity RHO of 90 °C-cm/W.

The overall cable adjustment factor is a correction factor that takes into account the differences in the cable's actual installation and operating conditions from the base conditions. This factor establishes the maximum load capability that results in an actual cable

life equal to or greater than that expected when operated at the base ampacity under the specified conditions.

The overall ampacity adjustment factor is composed of several components as indicated in Equation (13-4).

$$F = F_t F_{th} F_g \quad (13-4)$$

where

F_t is the adjustment factor to account for the differences in the ambient and conductor temperatures from the base case,

F_{th} is the adjustment factor to account for the difference in the soil thermal resistivity, from the RHO of 90 °C–cm/W at which the base ampacities are specified,

F_g is the adjustment factor to account for cable grouping.

To obtain the values of the adjustment factors F_{th} and F_g , an elaborate computer program was developed based on the Neher-McGrath method and was used to calculate the conductor temperatures for various arrangements. The program takes into account each adjustment factor in Equation (13-4) which together account for the more significant effects indicated in Figure 13-1 for underground installations. Thousands of computer runs were made to determine the adjustment factor tables. These tables were then verified by utilizing the NEC, IEEE Std 835-1994, and the *Underground Systems Reference Book* [B18]. Knutson and Miles [B1], Shokooh and Knutson 1988 [B14], and Shokooh and Knutson 1983 [B15] report the results of similar efforts for ampacity adjustment factors based on the Neher-McGrath method.

The various adjustment factors in Equation (13-4) are largely, but not completely, independent from each other. Although the computer program can simulate any complex configuration, for the sake of clarity, the ampacity adjustment tables reported here are based on the following simplifying assumptions:

- a) Cables for some voltage ratings and sizes are combined for the F_{th} tables. For some applications where RHO is considerably high (more than 180 °C–cm/W) and a mixed group of cables are installed, the interdependencies of the adjustment factors for different cable sizes may not be negligible and up to a 4% error in the overall conductor temperatures may be expected.
- b) The effect of the temperature rise due to the insulation dielectric losses is neglected for the temperature adjustment factor, F_t . This temperature rise for rubber and polyethylene insulated cables rated 15 kV and below (sizes 1000 kcmil and below) is less than 2 °C. However, this effect can be included in F_t by adding the temperature rise due to the dielectric losses to the ambient temperatures T_a and T'_a .
- c) The often negligible effects of any applicable sheath, shield, and metallic conduit losses depicted in Figure 13-1 are ignored.

In the final design case where accuracy and precision are required, the previously mentioned assumptions cannot be disregarded, and the ampacities obtained from the manual method can be used as an initial approximation for computer simulation of the actual design conditions.

13.4.1 F_t (ambient and conductor temperature adjustment factor)

This adjustment factor is used to determine the cable ampacity when the operating ambient temperature and/or the maximum allowable conductor temperature differ from the original temperatures at which the cable base ampacity is specified. The expression for calculating the effect of changes in the conductor and ambient temperatures on the base ampacity is given by F_t in Equations (13-5) and (13-6) for copper and aluminum conductors, respectively.

$$F_t = \left[\frac{T'_c - T'_a}{T_c - T_a} \times \frac{234.5 + T_c}{234.5 + T'_c} \right]^{1/2} \quad (\text{copper}) \quad (13-5)$$

$$F_t = \left[\frac{T'_c - T'_a}{T_c - T_a} \times \frac{228.1 + T_c}{228.1 + T'_c} \right]^{1/2} \quad (\text{aluminum}) \quad (13-6)$$

where

- T_c is the conductor rated temperature in °C at which the base ampacity is specified,
- T'_c is the maximum allowable conductor operating temperature in °C,
- T_a is the ambient temperature in °C at which the base ampacity is specified,
- T'_a is the actual (maximum) soil ambient temperature in °C.

The maximum operating ambient temperature is usually difficult to obtain and has to be estimated based on historical meteorological data. For application in underground cables, T'_a is the maximum soil temperature at the depth of installation at peak summertime. In general, seasonal temperature variations of the soil follow a roughly sinusoidal cycle with soil temperature peaking during the summer months. The effect of seasonal variation in soil temperature decreases with depth until the depths of 20–30 ft are reached, at which the soil temperature remains fairly constant.

Certain characteristics of the soil (texture, density, and moisture content) and soil pavement (asphalt, cement, etc.) have a noticeable effect on the soil temperature profile. For maximum accuracy, it is important to obtain T_a via a field test rather than using an approximate value based on the maximum atmospheric temperature. For cable installation in air, T_a is the maximum air temperature at peak summertime. Special attention should be given for cable applications in the shade or under direct sunlight.

Adjustment factors for typical copper conductor temperatures ($T_c = 90$ °C and 75 °C) and ambient temperatures ($T_a = 20$ °C for underground installation and 40 °C for above-ground installation) at which the base ampacities are specified, are calculated from Equation (13-5) and tabulated in Tables 13-1 through 13-4.

Table 13-1— F_t : Adjustment factor for various copper conductors and ambient temperatures when $T_c = 75\text{ }^\circ\text{C}$ and $T_a = 40\text{ }^\circ\text{C}$

T'_c in $^\circ\text{C}$	T'_a in $^\circ\text{C}$					
	30	35	40	45	50	55
60	0.95	0.87	0.77	0.67	0.55	0.39
75	1.13	1.07	<u>1.00</u>	0.93	0.85	0.76
90	1.28	1.22	1.17	1.11	1.04	0.98
110	1.43	1.34	1.34	1.29	1.24	1.19

Table 13-2— F_t : Adjustment factor for various copper conductors and ambient temperatures when $T_c = 90\text{ }^\circ\text{C}$ and $T_a = 40\text{ }^\circ\text{C}$

T'_c in $^\circ\text{C}$	T'_a in $^\circ\text{C}$					
	30	35	40	45	50	55
75	0.97	0.92	0.86	0.79	0.72	0.65
85	1.06	1.01	0.96	0.90	0.84	0.78
90	1.10	1.05	<u>1.00</u>	0.95	0.89	0.84
110	1.23	1.19	1.15	1.11	1.06	1.02
130	1.33	1.30	1.27	1.23	1.19	1.16

Table 13-3— F_t : Adjustment factor for various copper conductors and ambient temperatures when $T_c = 75\text{ }^\circ\text{C}$ and $T_a = 20\text{ }^\circ\text{C}$

T'_c in $^\circ\text{C}$	T'_a in $^\circ\text{C}$					
	10	15	20	25	30	35
60	0.98	0.93	0.87	0.82	0.76	0.69
75	1.09	1.04	<u>1.00</u>	0.95	0.90	0.85
90	1.18	1.14	1.10	1.06	1.02	0.98
110	1.29	1.25	1.21	1.18	1.14	1.11

Table 13-4— F_t : Adjustment factor for various copper conductors and ambient temperatures when $T_c = 90\text{ }^\circ\text{C}$ and $T_a = 20\text{ }^\circ\text{C}$

T'_c in $^\circ\text{C}$	T'_a in $^\circ\text{C}$					
	10	15	20	25	30	35
75	0.99	0.95	0.91	0.87	0.82	0.77
85	1.04	1.02	0.97	0.93	0.89	0.85
90	1.07	1.04	<u>1.00</u>	0.96	0.93	0.89
110	1.16	1.13	1.10	1.06	1.02	0.98
130	1.24	1.21	1.18	1.16	1.13	1.10

13.4.2 F_{th} (thermal resistivity adjustment factor)

Soil thermal resistivity (RHO) indicates the resistance to heat dissipation of the soil in $^\circ\text{C-cm/W}$. Tables 13-5 through 13-7 indicate the adjustment factors required when the actual soil thermal resistivity is different from the RHO of $90\text{ }^\circ\text{C-cm/W}$ at which the base ampacities are specified. These tables are calculated based on an assumption that the soil has a uniform and constant thermal resistivity.

Table 13-5— F_{th} : Thermal resistivity adjustment factor for 0–1000 V cables in duct banks with base ampacity given at an RHO of $90\text{ }^\circ\text{C-cm/W}$

Cable Size	Number of CKT	RHO ($^\circ\text{C-cm/W}$)							
		60	90	120	140	160	180	200	250
#12–#1	1	1.03	1.0	0.97	0.96	0.94	0.93	0.92	0.90
	3	1.06	1.0	0.95	0.92	0.89	0.87	0.85	0.82
	6	1.09	1.0	0.93	0.89	0.85	0.82	0.79	0.75
	9+	1.11	1.0	0.92	0.87	0.83	0.79	0.76	0.71
1/0–4/0	1	1.04	1.0	0.97	0.95	0.93	0.91	0.89	0.86
	3	1.07	1.0	0.94	0.90	0.87	0.85	0.83	0.80
	6	1.10	1.0	0.92	0.87	0.84	0.81	0.78	0.74
	9+	1.12	1.0	0.91	0.85	0.81	0.78	0.75	0.70
250–1000	1	1.05	1.0	0.96	0.94	0.92	0.90	0.88	0.85
	3	1.08	1.0	0.93	0.89	0.86	0.83	0.81	0.77
	6	1.11	1.0	0.91	0.86	0.83	0.80	0.77	0.72
	9+	1.13	1.0	0.90	0.84	0.80	0.77	0.74	0.69

Table 13-6— F_{th} : Thermal resistivity adjustment factor for 1001–35 000 V cables in duct banks with base ampacity given at an RHO of 90 °C-cm/W

Cable Size	Number of CKT	RHO (°C-cm/W)							
		60	90	120	140	160	180	200	250
#12–#1	1	1.03	1.0	0.97	0.95	0.93	0.91	0.90	0.88
	3	1.07	1.0	0.94	0.90	0.87	0.84	0.81	0.77
	6	1.09	1.0	0.92	0.87	0.84	0.80	0.77	0.72
	9+	1.10	1.0	0.91	0.85	0.81	0.77	0.74	0.69
1/0–4/0	1	1.04	1.0	0.96	0.94	0.92	0.90	0.88	0.85
	3	1.08	1.0	0.93	0.89	0.86	0.83	0.80	0.75
	6	1.10	1.0	0.91	0.86	0.82	0.79	0.77	0.71
	9+	1.11	1.0	0.90	0.84	0.80	0.76	0.73	0.68
250–1000	1	1.05	1.0	0.95	0.92	0.90	0.88	0.86	0.84
	3	1.09	1.0	0.92	0.88	0.85	0.82	0.79	0.74
	6	1.11	1.0	0.91	0.85	0.81	0.78	0.75	0.70
	9+	1.12	1.0	0.90	0.84	0.79	0.75	0.72	0.67

Table 13-7— F_{th} : Thermal resistivity adjustment factor for cables directly buried with base ampacity given at an RHO of 90 °C-cm/W

Cable Size	Number of CKT	RHO (°C-cm/W)							
		60	90	120	140	160	180	200	250
#12–#1	1	1.10	1.0	0.91	0.86	0.82	0.79	0.77	0.74
	2	1.13	1.0	0.90	0.85	0.81	0.77	0.74	0.70
	3+	1.14	1.0	0.89	0.84	0.79	0.75	0.72	0.67
1/0–4/0	1	1.13	1.0	0.91	0.86	0.81	0.78	0.75	0.71
	2	1.14	1.0	0.90	0.85	0.80	0.76	0.73	0.69
	3+	1.15	1.0	0.89	0.84	0.78	0.74	0.71	0.67
250–1000	1	1.14	1.0	0.90	0.85	0.81	0.78	0.75	0.71
	2	1.15	1.0	0.89	0.84	0.80	0.76	0.73	0.69
	3+	1.16	1.0	0.88	0.83	0.78	0.74	0.71	0.67

Typical values of thermal resistivity for various materials are as follows (see the NEC).

<u>Material type</u>	<u>(°C-cm/W)</u>
Solid paper insulation	700
Varnished cambric	600
Polyvinyl chloride (PVC)	650
Paper	550
Neoprene	519
Rubber, jute, textiles	500
Fiber duct	480
Polyethylene (PE)	450
Transite duct	200
Somastic	100
Concrete	55–85
Average soil	90
Very dry soil (rocky or sandy)	120
Damp soil (coastal areas, high water table)	60
EPR	400
Crosslinked polyethylene	370

The thermal resistivity of the soil depends on a number of factors, such as soil texture, moisture content, density, and structural arrangement of the soil grains. In general, higher density or moisture content of the soil results in a better heat dissipating ability and lower thermal resistivity. There is a tremendous variation in the soil thermal resistivities ranging from a RHO of less than 40 to more than 300 °C-cm/W. Based on these facts, it is apparent that direct testing of the soil is essential. Furthermore, it is important that this test be conducted after a prolonged dry spell at a peak summer temperature when the soil moisture content is minimal. The result of such a field test usually indicates a wide range of soil thermal resistance for a given depth over a test site. For the purpose of cable ampacity deratings, the maximum value of the thermal resistivities for a given cable route should be used.

The effect of soil dryout, which is caused by the continuous loading of the cables, can be taken into account by considering a RHO higher than the actual value obtained from the soil test. Use of dense sandy soil as backfill can lower the effective overall thermal resistivity and can offset the soil dryout effect. Dryout curves of RHO versus moisture content can be obtained to help select an appropriate value.

In cases where the soil thermal resistivity is very high and corrective backfill with low thermal resistivity is used, Tables 13-5 through 13-7 are inaccurate and may not produce cable ampacity values that are acceptable even on an approximate basis.

13.4.3 F_g (grouping adjustment factor)

Grouped cables will operate at a higher temperature than isolated cables. The increase in the operating temperature is due to the presence of the other cables in the group, which act as heat sources. Therefore, the amount of interference temperature rise from other cables in the group depends on the separation of the cables and the surrounding media.

In this subclause, adjustment factors for cables installed with maintained separation in underground duct banks and for directly buried cables are given in Tables 13-8 through 13-11. For cable separations other than those considered in these tables, one can use one's own judgment for estimating the value of F_g or use a computer program directly without an initial approximation for the grouping effect. In general, increasing the horizontal and vertical spacing between the cables would decrease the temperature interference between them and, therefore, increase the value of F_g .

Table 13-8— F_g : Grouping adjustment factor for 0–5000 V 3/C, or triplexed cables in duct banks (no spare ducts, nonmetallic conduits of 5 in with center-to-center spacing of 7.5 in)

Cable size	No. of rows	Number of columns														
		1	2	3	4	5	6	7	8	9	10	11	12	13	14	15
#8	1	1.00	.942	.885	.835	.795	.768	.745	.727	.710	.698	.688	.679	.671	.664	.658
	2	.930	.840	.772	.723	.687	.660	.638	.620	.604	.592	.582	.572	.564	.557	.550
	3	.870	.772	.694	.632	.596	.569	.548	.532	.519	.508	.498	.490	.482	.476	.470
	4	.820	.710	.629	.571	.536	.509	.490	.472	.458	.446	.436	.428	.420	.412	.405
#6	1	1.00	.930	.874	.826	.790	.760	.737	.718	.702	.690	.680	.671	.663	.656	.650
	2	.920	.813	.747	.700	.665	.638	.615	.598	.583	.572	.561	.552	.544	.537	.530
	3	.860	.747	.679	.625	.588	.560	.540	.525	.510	.498	.490	.481	.473	.467	.460
	4	.810	.700	.620	.565	.531	.503	.484	.467	.452	.440	.431	.422	.415	.408	.400
#4	1	1.00	.925	.871	.817	.781	.750	.726	.707	.691	.678	.668	.659	.651	.646	.640
	2	.920	.809	.742	.693	.659	.632	.610	.593	.579	.567	.555	.547	.539	.530	.525
	3	.850	.742	.668	.615	.578	.551	.531	.514	.500	.489	.480	.471	.464	.458	.450
	4	.805	.690	.610	.560	.524	.497	.477	.460	.447	.435	.425	.418	.410	.401	.395
#2	1	1.00	.918	.858	.808	.770	.741	.720	.701	.688	.677	.667	.658	.650	.641	.635
	2	.920	.800	.723	.680	.648	.623	.602	.586	.572	.560	.549	.540	.530	.522	.514
	3	.840	.723	.657	.608	.568	.540	.520	.504	.490	.479	.470	.461	.454	.447	.440
	4	.800	.685	.608	.553	.518	.490	.471	.453	.440	.429	.420	.411	.402	.395	.390
#1	1	1.00	.918	.849	.799	.753	.721	.699	.682	.669	.659	.650	.643	.639	.632	.630
	2	.920	.795	.702	.650	.613	.583	.563	.546	.530	.520	.510	.502	.494	.488	.482
	3	.830	.702	.618	.562	.525	.500	.480	.464	.450	.440	.430	.421	.413	.406	.400
	4	.740	.634	.551	.497	.465	.440	.421	.405	.392	.383	.374	.366	.359	.352	.348
1/0	1	1.00	.910	.842	.791	.745	.716	.694	.678	.665	.655	.646	.639	.635	.628	.626
	2	.915	.790	.700	.642	.604	.575	.555	.537	.523	.511	.503	.494	.486	.480	.475
	3	.817	.700	.610	.554	.520	.494	.474	.457	.444	.432	.424	.415	.408	.400	.394
	4	.735	.629	.546	.492	.460	.435	.417	.402	.391	.381	.371	.363	.355	.349	.343
2/0	1	1.00	.910	.842	.791	.745	.716	.694	.678	.665	.655	.646	.639	.635	.628	.626
	2	.915	.790	.700	.642	.604	.575	.555	.537	.523	.511	.503	.494	.486	.480	.475
	3	.817	.700	.610	.554	.520	.494	.474	.457	.444	.432	.424	.415	.408	.400	.394
	4	.735	.629	.546	.492	.460	.435	.417	.402	.391	.381	.371	.363	.355	.349	.343
3/0	1	1.00	.910	.842	.791	.745	.716	.694	.678	.665	.655	.646	.639	.635	.628	.626
	2	.915	.790	.700	.642	.604	.575	.555	.537	.523	.511	.503	.494	.486	.480	.475
	3	.817	.700	.610	.554	.520	.494	.474	.457	.444	.432	.424	.415	.408	.400	.394
	4	.735	.629	.546	.492	.460	.435	.417	.402	.391	.381	.371	.363	.355	.349	.343
4/0	1	1.00	.908	.830	.780	.737	.709	.690	.673	.660	.650	.642	.635	.628	.623	.619
	2	.910	.770	.684	.635	.599	.570	.550	.532	.518	.506	.498	.489	.481	.475	.470
	3	.810	.684	.602	.548	.515	.489	.469	.452	.440	.429	.420	.411	.403	.397	.391
	4	.730	.624	.541	.487	.456	.431	.414	.399	.388	.378	.368	.360	.352	.346	.341
250	1	1.00	.905	.830	.777	.725	.692	.668	.646	.628	.615	.603	.597	.590	.583	.580
	2	.890	.770	.675	.609	.570	.542	.519	.500	.485	.474	.466	.458	.450	.445	.440
	3	.780	.675	.579	.518	.480	.454	.434	.420	.408	.398	.390	.383	.378	.373	.370
	4	.694	.588	.512	.460	.422	.397	.379	.364	.352	.345	.338	.331	.327	.323	.320

Table 13-8— F_g : Grouping adjustment factor for 0–5000 V 3/C, or triplexed cables in duct banks (no spare ducts, nonmetallic conduits of 5 in with center-to-center spacing of 7.5 in) (Continued)

Cable size	No. of rows	Number of columns														
		1	2	3	4	5	6	7	8	9	10	11	12	13	14	15
350	1	1.00	.905	.830	.770	.720	.688	.661	.640	.622	.608	.597	.590	.583	.578	.573
	2	.887	.749	.664	.609	.570	.540	.518	.499	.484	.474	.465	.458	.450	.445	.440
	3	.775	.664	.575	.515	.479	.453	.433	.419	.406	.397	.389	.382	.377	.372	.369
	4	.690	.587	.511	.457	.421	.395	.377	.362	.351	.343	.336	.330	.325	.321	.318
500	1	1.00	.897	.815	.762	.708	.678	.652	.630	.613	.599	.588	.581	.575	.570	.565
	2	.882	.745	.656	.608	.569	.539	.516	.498	.483	.473	.463	.457	.450	.444	.439
	3	.770	.656	.570	.514	.478	.452	.432	.417	.404	.395	.388	.381	.375	.370	.367
	4	.685	.585	.510	.454	.420	.393	.374	.360	.349	.340	.333	.328	.323	.319	.315
750	1	1.00	.890	.802	.747	.700	.670	.640	.622	.605	.590	.580	.572	.566	.560	.555
	2	.870	.725	.641	.591	.552	.522	.500	.484	.469	.457	.448	.440	.434	.430	.425
	3	.760	.641	.560	.507	.470	.445	.425	.410	.398	.389	.380	.374	.369	.363	.360
	4	.680	.579	.501	.448	.413	.389	.371	.357	.346	.337	.330	.323	.318	.314	.310
1000	1	1.00	.885	.795	.740	.695	.665	.639	.618	.600	.585	.574	.567	.561	.555	.551
	2	.858	.716	.632	.582	.544	.513	.493	.474	.460	.448	.439	.431	.425	.420	.415
	3	.748	.632	.551	.499	.464	.439	.419	.403	.392	.383	.375	.369	.363	.358	.355
	4	.676	.574	.497	.444	.409	.385	.367	.353	.342	.333	.326	.319	.315	.311	.308

Table 13-9— F_g : Grouping adjustment factor for 5001–35 000 V 3/C, or triplexed cables in duct banks (no spare ducts, nonmetallic conduits of 5 in with center-to-center spacing of 7.5 in)

Cable size	No. of rows	Number of columns														
		1	2	3	4	5	6	7	8	9	10	11	12	13	14	15
#6	1	1.00	.920	.854	.803	.758	.726	.699	.678	.660	.646	.635	.628	.620	.615	.610
	2	.920	.800	.714	.660	.620	.590	.570	.552	.540	.530	.521	.515	.509	.503	.500
	3	.840	.714	.625	.569	.530	.501	.484	.470	.459	.450	.442	.436	.429	.423	.420
	4	.770	.642	.560	.506	.469	.441	.422	.406	.394	.385	.378	.371	.367	.362	.358
#4	1	1.00	.920	.852	.800	.755	.722	.695	.673	.655	.642	.630	.623	.615	.610	.605
	2	.920	.795	.714	.660	.620	.590	.570	.552	.540	.530	.521	.515	.509	.503	.500
	3	.835	.709	.615	.561	.521	.493	.474	.459	.448	.439	.430	.424	.420	.416	.412
	4	.760	.630	.548	.498	.460	.430	.410	.395	.382	.374	.367	.361	.356	.352	.350
#2	1	1.00	.910	.836	.784	.748	.714	.688	.665	.649	.635	.625	.616	.609	.602	.598
	2	.920	.782	.689	.639	.599	.570	.548	.531	.518	.508	.500	.494	.489	.484	.480
	3	.820	.689	.600	.544	.505	.479	.460	.445	.433	.424	.417	.410	.405	.400	.395
	4	.746	.622	.539	.484	.445	.415	.396	.382	.370	.361	.353	.348	.342	.338	.334
#1	1	1.00	.905	.827	.777	.731	.697	.670	.645	.626	.610	.598	.588	.579	.571	.565
	2	.920	.771	.681	.629	.590	.560	.538	.519	.502	.491	.480	.471	.462	.455	.450
	3	.816	.681	.588	.532	.497	.469	.448	.432	.418	.407	.397	.389	.382	.376	.370
	4	.785	.605	.524	.471	.435	.410	.390	.376	.364	.353	.347	.340	.333	.328	.323
1/0	1	1.00	.904	.825	.775	.729	.695	.668	.643	.624	.609	.597	.587	.578	.570	.564
	2	.912	.765	.671	.619	.580	.549	.527	.509	.494	.481	.471	.462	.453	.446	.440
	3	.811	.671	.581	.525	.488	.460	.440	.423	.409	.398	.387	.379	.372	.365	.359
	4	.730	.604	.518	.464	.431	.406	.385	.372	.359	.349	.341	.335	.329	.324	.320

Table 13-9— F_g : Grouping adjustment factor for 5001–35 000 V 3/C, or triplexed cables in duct banks (no spare ducts, nonmetallic conduits of 5 in with center-to-center spacing of 7.5 in) (Continued)

Cable size	No. of rows	Number of columns														
		1	2	3	4	5	6	7	8	9	10	11	12	13	14	15
2/0	1	1.00	.904	.823	.773	.728	.694	.668	.643	.624	.609	.580	.597	.587	.578	.570
	2	.903	.761	.667	.612	.573	.542	.520	.500	.488	.475	.463	.455	.448	.441	.434
	3	.800	.667	.578	.520	.482	.454	.433	.418	.402	.391	.382	.374	.367	.360	.353
	4	.722	.597	.511	.460	.425	.400	.380	.365	.353	.343	.335	.329	.322	.317	.312
3/0	1	1.00	.898	.814	.765	.722	.690	.661	.637	.618	.602	.590	.580	.571	.563	.556
	2	.898	.752	.664	.609	.570	.539	.513	.498	.483	.471	.461	.451	.443	.437	.429
	3	.802	.664	.572	.514	.479	.451	.430	.414	.399	.388	.379	.371	.364	.357	.350
	4	.720	.593	.508	.456	.421	.396	.377	.362	.350	.340	.332	.327	.320	.314	.310
4/0	1	1.00	.894	.811	.762	.717	.682	.653	.631	.612	.597	.585	.574	.566	.558	.550
	2	.896	.743	.656	.603	.565	.536	.513	.496	.480	.468	.459	.449	.441	.434	.427
	3	.795	.656	.564	.513	.474	.447	.427	.411	.397	.386	.377	.369	.362	.355	.349
	4	.711	.584	.502	.450	.417	.392	.374	.359	.348	.338	.329	.324	.317	.311	.307
250	1	1.00	.892	.811	.762	.715	.679	.645	.620	.600	.583	.572	.564	.557	.552	.550
	2	.885	.741	.654	.594	.552	.523	.500	.482	.469	.457	.447	.438	.430	.422	.416
	3	.785	.654	.559	.498	.459	.429	.408	.388	.373	.361	.351	.342	.335	.328	.321
	4	.701	.580	.500	.448	.414	.385	.365	.348	.332	.321	.311	.302	.295	.288	.281
350	1	1.00	.890	.807	.754	.700	.661	.634	.609	.589	.572	.561	.552	.548	.542	.540
	2	.872	.733	.641	.580	.538	.510	.488	.470	.455	.443	.432	.423	.415	.408	.400
	3	.772	.641	.550	.492	.451	.420	.396	.377	.362	.350	.340	.331	.323	.316	.310
	4	.681	.572	.491	.440	.402	.375	.354	.337	.322	.311	.300	.292	.285	.278	.271
500	1	1.00	.885	.801	.745	.692	.650	.620	.593	.573	.559	.548	.539	.533	.529	.526
	2	.862	.728	.634	.572	.531	.502	.480	.462	.447	.435	.425	.415	.407	.400	.391
	3	.765	.634	.542	.483	.446	.415	.391	.373	.358	.346	.335	.327	.319	.311	.305
	4	.676	.574	.497	.444	.409	.385	.367	.353	.342	.333	.326	.319	.315	.311	.308
750	1	1.00	.879	.790	.780	.682	.647	.615	.589	.570	.556	.545	.536	.530	.524	.520
	2	.850	.710	.622	.560	.520	.490	.469	.450	.436	.424	.412	.402	.394	.388	.381
	3	.755	.622	.530	.479	.441	.410	.387	.368	.352	.341	.331	.322	.314	.307	.300
	4	.671	.560	.480	.430	.392	.366	.345	.328	.314	.302	.292	.284	.277	.270	.263
1000	1	1.00	.873	.786	.730	.680	.642	.609	.582	.562	.548	.537	.528	.521	.516	.512
	2	.844	.705	.614	.554	.514	.485	.463	.445	.430	.418	.406	.397	.390	.383	.376
	3	.745	.614	.523	.472	.434	.403	.381	.363	.348	.337	.327	.318	.309	.301	.294
	4	.663	.552	.473	.422	.385	.359	.338	.321	.307	.295	.285	.278	.270	.263	.256

Table 13-10— F_g : Grouping adjustment factor for directly buried 3/C, or triplexed cables (7.5 in horizontal and 10 in center-to-center vertical spacing)

Number of layers	Number of horizontal cables						
	1	2	3	4	6	9	12
1	1.0	0.82	0.70	0.63	0.56	0.51	0.49
2	0.81	0.62	0.53	0.48	0.41	—	—

Table 13-11— F_g : Grouping adjustment factor for directly buried 1/C, or triplexed cables (7.5 in horizontal and 10 in center-to-center vertical spacing)

Number of layers	Number of horizontal cables			
	3	6	9	12
1	1.0	0.79	0.71	0.68
2	0.73	0.58	—	—

Based on the computer studies for duct bank installations, it was found that the size and voltage rating of the cables make a noticeable difference in the value of F_g . Therefore, the adjustment factors for cable groupings are tabulated as functions of cable sizes and voltage ratings. For applications where a mixed group of cables are installed in a duct bank, the value of F_g will be different for each cable size. In this case, it is recommended that cable ampacities be determined as the location of the cables is progressively changed from the worst (hottest) conduit locations and the best (coolest) conduit locations to establish the most economical arrangement.

Note that no grouping adjustment factor is given for cables installed in air or in conduits in air. Refer to the NEC and IEEE Std 835-1994 for the allowable ampacities of cable installed in conduits in air.

13.5 Example

To illustrate the use of the method described in this chapter, a 3×5 duct bank system (3 rows, 5 columns) is considered. The duct bank contains 350 kcmil and 500 kcmil (15 kV, 3/C) copper cables. Ducts are a diameter of 5 in (trade size) of PVC, and are separated by 7.5 in (center-to-center spacing), as shown in Figure 13-3. The soil thermal resistivity (RHO) is 120 °C-cm/W, and the maximum soil ambient temperature is 30 °C.

The objective of this example is to determine the maximum ampacities of the cables under the specified conditions of use, i.e., to limit the conductor temperature of the hottest location to 75 °C (an NEC requirement for wet locations). To achieve this, the base ampacities of the cables are found first. These ampacities are then derated using the adjustment factors. The computer program is then used to verify the derated ampacities by calculating the actual conductor temperatures.

The depth of the duct bank is set at 30 in for this example. For average values of soil thermal resistivity, the depth can be varied by approximately $\pm 10\%$ without drastically affecting the resulting ampacities. However, larger variations in the bank depth, or larger soil thermal resistivities, may significantly affect ampacities.

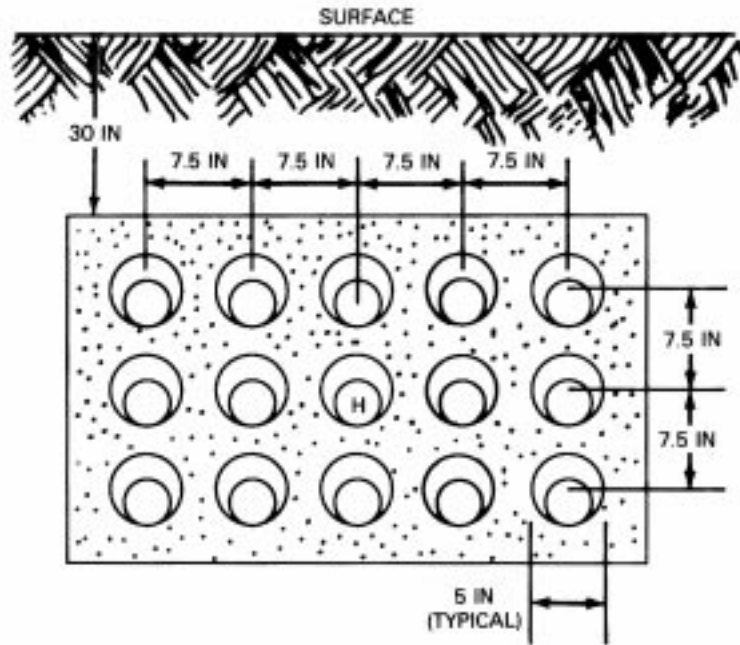

Figure 13-3—3 × 5 duct bank arrangement

13.5.1 Base ampacities

From the NEC ampacity tables, the base ampacities of 15 kV three-conductor cables under an isolated condition and based on a conductor temperature of 90 °C, ambient soil temperature of 20 °C, and thermal resistivity (RHO) of 90 °C-cm/W are as follows:

$$I = 375 \text{ A (350 kcmil)}$$

$$I = 450 \text{ A (500 kcmil)}$$

13.5.2 Manual method

The required ampacity adjustment factors for the ambient and conductor temperatures, thermal resistivity, and grouping are as follows:

$$F_t = 0.82 \text{ for adjustment in the ambient temperature from 20–30 °C and conductor temperature from 90–75 °C (see Table 13-4).}$$

$$F_{th} = 0.90 \text{ for adjustment in the thermal resistivity from a RHO of 90–120 °C-cm/W (see Table 13-6).}$$

$F_g = 0.479$ for grouping adjustment of 15 kV, 3/C 350 kcmil cables installed in a 3×5 duct bank (see Table 13-8).

$F_g = 0.478$ for grouping adjustment of 15 kV, 3/C 500 kcmil cables installed in a 3×5 duct bank (see Table 13-8).

The overall cable adjustment factors are:

$$F = 0.82 \times 0.90 \times 0.479 = 0.354 \text{ (350 kcmil cables)}$$

$$F = 0.82 \times 0.90 \times 0.478 = 0.353 \text{ (500 kcmil cables)}$$

The maximum allowable ampacity of each cable size is the multiplication product of the cable base ampacity by the overall adjustment factor. This ampacity adjustment would limit the temperature of the hottest conductor to 75 °C when all of the cables in the duct bank are loaded at 100% of their derated ampacities.

$$I' = 375 \times 0.354 = 133 \text{ A (350 kcmil cables)}$$

$$I' = 450 \times 0.353 = 159 \text{ A (500 kcmil cables)}$$

13.5.3 Computer method

As the last step, a computer program is run to simulate the actual conductor temperature using the ampacities determined by the manual method. The computer program used here is the same program that was used to generate the ampacity adjustment factors. The output report of the program is shown in Figure 13-4, where (a) indicates all input parameters and (b) indicates conduit locations and conductor temperatures.

The objective for this design was to find the cable ampacities that would limit the conductor temperature to 75 °C. The results of the computer study indicate that the hottest conductor is located in the middle row (2) and middle column (3) with a temperature of 74.3 °C. The ampacities obtained from the manual method for this simplified example case exactly agree with the ampacities obtained by the computer calculations. In more general cases, however, where the assumptions listed in 13.4 do not apply, computer calculation would be necessary to establish final ampacities

Project: Example		Page: 1									
Location: Irvine, California		Date: 09-01-1989									
Contract: 1234567		Study: SC-100									
Engineer: F. S.											
Cable ampacity derating example—3 × 5 duct bank application											
Cable size	No. of cond.	Volt (kV)	Type	DC resistance (μΩ/ft)	O.D. (in)	Insul. thermal R (Ω/ft)	Dielectric losses (W/ft)	Y _c	Y _s		
500	3	15	CU	21.60	2.590	1.430	0.056	0.018	0.000		
350	3	15	CU	30.80	2.290	1.564	0.048	0.009	0.000		
Installation	Conduit type	No. of rows	No. of cols.	Ref. depth (in)	Height (in)	Width (in)	RHO		Ambient temp. °C		
							Soil	Fill			
Duct bank	PVC	3	5	30.0	27.0	42.0	120.0	90.0	30.0		
Row	Col.	Horiz. dist. (in)	Vert. dist. (in)	Load current (A)	Cable					Conduit (in)	
					No.	C/C	Size	kV	Type	Size	Thick-ness
1	1	6.00	6.00	159.0	1	3	500	15	CU	5.040	0.260
2	1	6.00	13.50	159.0	1	3	500	15	CU	5.040	0.260
3	1	6.00	21.00	159.0	1	3	500	15	CU	5.040	0.260
1	2	13.50	6.00	159.0	1	3	500	15	CU	5.040	0.260
2	2	13.50	13.50	159.0	1	3	500	15	CU	5.040	0.260
3	2	13.50	21.00	159.0	1	3	500	15	CU	5.040	0.260
1	3	21.00	6.00	133.0	1	3	350	15	CU	5.040	0.260
2	3	21.00	13.50	133.0	1	3	350	15	CU	5.040	0.260
3	3	21.00	21.00	133.0	1	3	350	15	CU	5.040	0.260
1	4	28.50	6.00	133.0	1	3	350	15	CU	5.040	0.260
2	4	28.50	13.50	133.0	1	3	350	15	CU	5.040	0.260
3	4	28.50	21.00	133.0	1	3	350	15	CU	5.040	0.260
1	5	37.00	6.00	133.0	1	3	350	15	CU	5.040	0.260
2	5	37.00	13.50	133.0	1	3	350	15	CU	5.040	0.260
3	5	37.00	21.00	133.0	1	3	350	15	CU	5.040	0.260

(a) Input parameters

Figure 13-4—Computer program output report for cable ampacity derating

Project:	Example	Page:	2
Location:	Irvine, California	Date:	09-01-1989
Contract:	1234567	Study:	SC-100
Engineer:	F. S.		

Cable ampacity derating example—3 × 5 duct bank application						
	Columns	1	2	3	4	5
Row 1	Cable:	500	500	350	350	350
	Amp:	159.0	159.0	133.0	133.0	133.0
	Temp:	66.8	69.7	70.9	69.9	66.6
Row 2	Cable:	500	500	350	350	350
	Amp:	159.0	159.0	133.0	133.0	133.0
	Temp:	69.7	73.0	74.3	73.1	69.3
Row 3	Cable:	500	500	350	350	350
	Amp:	159.0	159.0	133.0	133.0	133.0
	Temp:	69.3	72.3	73.5	72.4	69.0

(b) Conduit locations and conductor temperatures**Figure 13-4—Computer program output report
for cable ampacity derating (*Continued*)****13.6 Conclusion**

Analytical derating of cable ampacity is a complex and tedious process. A manual method was developed in this chapter that uses adjustment factors to simplify cable derating for some very specific conditions of use and produce close approximations to actual ampacities. The results from the manual method can then be entered as the initial ampacities for input into a cable ampacity computer program. The speed of the computer allows the program to use a more complex model, which considers factors specific to a particular installation and can iteratively adjust the conductor resistances as a function of temperature. The following is a list of factors that are specific for the cable system:

- Conduit type
- Conduit wall thickness
- Conduit inside diameter
- Asymmetrical spacing of cables or conduits
- Conductor load currents and load cycles
- Height, width, and depth of duct bank
- Thermal resistivity of backfill and/or duct bank
- Thermal resistance of cable insulation
- Dielectric losses of cable insulation
- AC/DC ratio of conductor resistance

The results from the computer program should be compared with the initial ampacities found by the manual process to determine whether corrective measures, i.e., changes in cable sizes,

duct rearrangement, etc., are required. Many computer programs alternatively calculate cable temperatures for a given ampere loading or cable ampacities at a given temperature. Some recently developed computer programs perform the entire process to size the cables automatically. To find an optimal design, the cable ampacity computer program simulates many different cable arrangements and loading conditions, including future load expansion requirements. This optimization is important in the initial stages of cable system design since changes to cable systems are costly, especially for underground installations. Additionally, the downtime required to correct a faulty cable design may be very long.

13.7 References

IEEE Std 835-1994, Standard Power Cable Ampacity Tables.³

NFPA 70-1996, National Electrical Code[®] (NEC[®]).⁴

13.8 Bibliography

[B1] Knutson, H. M., and Miles, B. B., "Cable derating parameters and their effects," IEEE paper no. PCIC-77-5, 1977.

[B2] *National Electrical Code Committee Report*, 1980 Annual Meeting.

[B3] *National Electrical Code Committee Report*, 1986 Annual Meeting.

[B4] *National Electrical Code Committee Report*, 1989 Annual Meeting.

[B5] *National Electrical Code Technical Committee Documentation*, 1980 Annual Meeting.

[B6] *National Electrical Code Technical Committee Documentation*, 1983 Annual Meeting.

[B7] *National Electrical Code Technical Committee Documentation*, 1986 Annual Meeting.

[B8] *National Electrical Code Technical Committee Documentation*, 1989 Annual Meeting.

[B9] *National Electrical Code Technical Committee Report*, 1983 Annual Meeting.

[B10] Neher, J. H., and McGrath, M. H., "The calculations of the temperature rise and load capability of cable systems," *AIEE Transactions on Power Applications Systems*, vol. 76, pt. III, pp. 752–772, Oct. 1957.

³IEEE publications are available from the Institute of Electrical and Electronics Engineers, 445 Hoes Lane, P.O. Box 1331, Piscataway, NJ 08855-1331, USA.

⁴The NEC is available from Publications Sales, National Fire Protection Association, 1 Batterymarch Park, P.O. Box 9101, Quincy, MA 02269-9101, USA. It is also available from the Institute of Electrical and Electronics Engineers, 445 Hoes Lane, P.O. Box 1331, Piscataway, NJ 08855-1331, USA.

[B11] NEMA Subcommittee Final Report, *Determination of Maximum Permissible Current Carrying Capacity of Code Insulated Wires and Cable for Building Purposes, Part IV*.⁵

[B12] Rosch, S. J., "The current-carrying capacity of rubber insulated conductors," paper presented at AIEE meeting, New York City, Jan. 27, 1938.

[B13] Schurig, O. R., and Frick, G. W., "Heating and current-carrying capacity of bare conductors for outdoor service," *General Electric Review*, vol. 33, Schenectady, NY, p. 141, 1930.

[B14] Shokooh, F., and Knutson, H. M., "Ampacity derating of underground cables," IEEE paper no. CH2581-7/88, presented at the I&CPS conference in Baltimore, MD, May 1988.

[B15] Shokooh, F., and Knutson, H. M., "A simple approach to cable ampacity rating," IEEE paper no. PCIC-83-16, presented at the IEEE/PCIC conference in Denver, CO, Sept. 1983.

[B16] Simmons, D. M., "Calculation of the Electrical Problems of Underground Cables," *The Electric Journal*, East Pittsburgh, PA, May–Nov. 1932.

[B17] Study NBSIR 78-1477, Department of Energy, Washington, DC.

[B18] *Underground Systems Reference Book*, EEI publication no. 55-16, Edison Electric Institute, New York City, NY, 1957.

[B19] Zipse, D. W., "Ampacity Tables—Demystifying the Myths," presented at the IEEE/PCIC conference, Sept. 1988.

⁵NEMA publications are available from the National Electrical Manufacturers Association, 1300 N. 17th St., Ste. 1847, Rosslyn, VA 22209, USA.

Chapter 14

Ground mat studies

14.1 Introduction

A ground mat study has one primary purpose: to determine if a ground mat design will limit the neutral-to-ground voltages normally present during ground faults to values that the average person can tolerate. Equipment protection or system operation is rarely an objective of a ground mat study. Historically, only utilities and unusually large industrial plants have been concerned with this type of study. However, the trend of power systems toward ever-increasing short-circuit capability has made safe ground mat design a criterion for all sizes of substations. This chapter will briefly review the theoretical background behind ground mat studies and discuss its application in the design of a ground mat by computer program.

14.2 Justification for ground mat studies

Virtually every exposed metallic object in an industrial facility is connected to ground, either deliberately or by accident. Under normal operating conditions, these conductors will be at the same potential as the surrounding earth. However, during ground faults, the absolute potential of the grounding system will rise (often to thousands of volts) along with any structural steel tied to the grounding system. Because any metal is a relatively good conductor, the steelwork everywhere will be at essentially the same voltage for most industrial installations. Most soils are poor conductors, however, and the flow of fault current through the earth will create definite and sometimes deadly potential gradients. Ground mat studies calculate the voltage difference between the grounding grid and points at the earth's surface and evaluate the shock hazard involved. Moreover, a computerized ground mat analysis of the type described herein allows the designer to specifically identify unsafe areas within a proposed mat and to optimize the mat design while verifying that the design is safe throughout the area in question.

14.3 Modeling the human body

To properly understand the analytical techniques involved in a ground mat study, it is necessary to understand the electrical characteristics of the most important part of the circuit: the human body. A normal healthy person can feel a current of about 1 mA. (Tests have long ago established that electric shock effects are the result of current and not voltage.) Currents of approximately 10–25 mA can cause lack of muscular control. In most men, 100 mA will cause ventricular fibrillation. Higher currents can stop the heart completely or cause severe electrical burns.

For practical reasons, most ground mat studies use the threshold of ventricular fibrillation, rather than muscular paralysis or other physiological factors, as their design criterion. Ventricular fibrillation is a condition in which the heart beats in an abnormal and ineffective

manner, with fatal results. Accordingly, most ground mats are designed to limit body currents to values below this threshold. Tests on animals with body and heart weights comparable to those of a human have determined that 99.5% of all healthy humans can tolerate a current through the heart region defined by

$$I_b = \frac{0.116}{\sqrt{T}} \quad (14-1)$$

where

I_b is the maximum body current in amperes, and
 T is the duration of current in seconds,

without going into ventricular fibrillation. This equation applies to both men and women with 0.116 used as the constant of proportionality, but is valid only for 60 Hz currents. In practice, most fault currents have a dc offset. This dc component is represented by a correction factor described in 14.4.2.

Tests indicate that the heart requires about 5 min to return to normal after experiencing a severe electrical shock. This implies that two or more closely spaced shocks (such as those that would occur in systems with automatic reclosing) would tend to have a cumulative effect. Present industry practice considers two closely spaced shocks (T_1 and T_2) to be equivalent to a single shock (T_3) whose duration is the sum of the intervals of the individual shocks ($T_1 + T_2 = T_3$).

Although there are many possible ways that a person may be shocked, industry practice is to evaluate shock hazards for two common, standard conditions. Figures 14-1 and 14-2 show these situations and their equivalent resistance diagrams. Figure 14-1 shows a touch contact with current flowing from the operator's hand to his feet. Figure 14-2 shows a step contact where current flows from one foot to the other. In each case, the body current I_b is driven by the potential difference between points A and B. Exposure to touch potential normally poses a greater danger than exposure to step potential. The step potentials are usually smaller in magnitude, the corresponding body resistance greater, and the permissible body current higher than for touch contacts. (The fibrillation current is the same for both types of contact. In the case of step potentials, however, not all current flowing from one leg to the other will pass through the heart region.) The worst possible touch potential (called "mesh potential") occurs at or near the center of a grid mesh. Accordingly, industry practice has made the mesh potential the standard criterion for determining safe ground mat design. In most cases, controlling mesh potentials will bring step potentials well within safe limits. Step potentials can, however, reach dangerous levels at points immediately outside the grid.

Since the body of an individual who is exposed to an electrical shock forms a shunt branch in an electrical circuit, the resistance of this branch must be determined to calculate the corresponding body current. Generally, the hand and foot contact resistances are considered to be negligible. However, the resistance of the soil directly underneath the foot is usually significant. Treating the foot as a circular plate electrode gives an approximate resistance of $3 \rho_s$, where ρ_s is the soil resistivity. The body itself has a total measured resistance of about

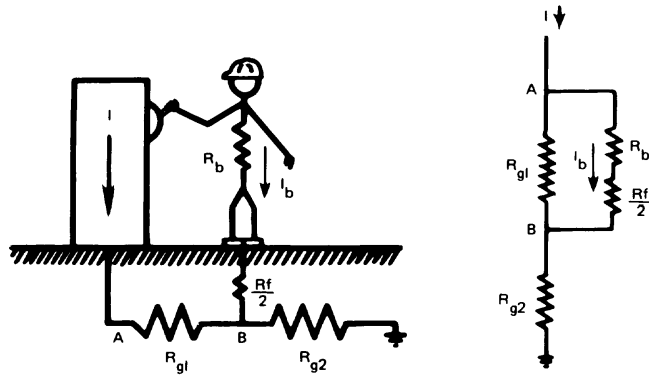

Figure 14-1—Touch potential

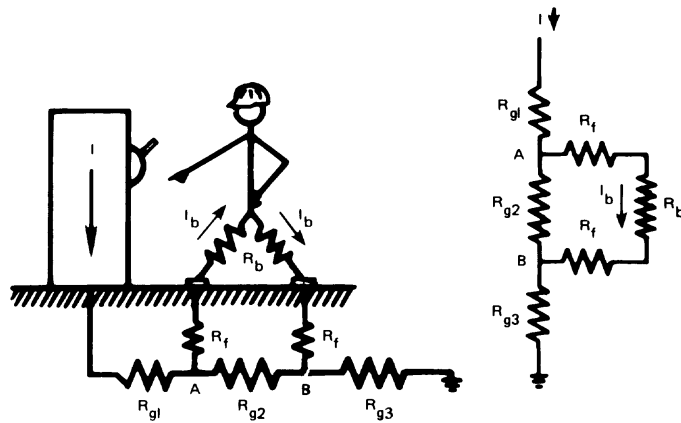

Figure 14-2—Step potential

2300 Ω hand to hand or 1100 Ω hand to foot. In the interest of simplicity and conservatism, IEEE Std 80-1986¹ recommends the use of 1000 ohms as a reasonable approximation for body resistance in both models. This yields a total branch resistance

$$R = 1000 \Omega + 6 \rho_s \tag{14-2}$$

for foot-to-foot resistance, and

$$R = 1000 \Omega + 1.5 \rho_s \tag{14-3}$$

¹Information on references can be found in 14.10.

for hand-to-foot resistance where ρ_s is the surface resistivity in ohm-meters ($\Omega \cdot m$) and R is expressed in ohms (Ω). If the station surface has been dressed with crushed rock or some other high resistivity material, the resistivity of the surface layer material should be used in Equations (14-2) and (14-3).

Because potential is easier to calculate and measure than current, the fibrillation threshold given by Equation (14-1) is normally expressed in terms of voltage. Combining Equations (14-1), (14-2), and (14-3) gives the maximum tolerable step and touch potentials:

$$E_{\text{step-tolerable}} = \frac{(1000 \Omega + 6 \rho_s)(0.116)}{\sqrt{T}} \quad (14-4)$$

$$E_{\text{touch-tolerable}} = \frac{(1000 \Omega + 1.5 \rho_s)(0.116)}{\sqrt{T}} \quad (14-5)$$

Because these voltages are dependent on surface resistivity, most industrial facilities have several different values for each tolerable voltage to match the various surface materials found in the plant.

Although in each of the cases discussed, body resistance shunts a part of the ground resistance, its actual effect on voltage and current distribution in the overall system is negligible. This becomes obvious when the normal magnitude of the ground fault current (as much as several thousand amperes) is compared to the desired body current (usually no more than several hundred milliamperes).

14.4 Traditional analysis of the ground mat

The voltage rise of any point within the grid depends upon three basic factors: ground-resistivity, available fault current, and grid geometry.

14.4.1 Ground resistivity

Most ground mat studies assume that the ground grid is buried in homogeneous soil. This is a good model for most soils and simplifies the calculations considerably. Also, many nonhomogeneous soils can be modeled by two-layer techniques. Although reasonably straightforward, these methods involve quite a bit of calculation, making computation by hand difficult. Normally, the two-layer model is necessary only for locations where bedrock and other natural soil layers with different resistivities are close enough to the surface and/or grid to severely affect the distribution of current.

Of far more serious concern are soils that experience drastic and unpredictable changes in resistivity at various points on the surface. These situations present the following problems:

- a) Difficulty of modeling the soil in calculations
- b) Physical difficulties in finding the area boundaries in the field and measuring each area's local resistivity

At present, these cases are normally handled by the inclusion of a safety margin in the value used for soil resistivity.

IEEE Std 80-1986 and Sunde [B19]² contain descriptions of simple methods of measuring soil resistivity for homogeneous and two-layer soils. Because soil resistivity varies with moisture content and, to a lesser degree, with temperature, ideally these measurements should be made over a period of time under different weather conditions. If, for some reason, an actual measurement of resistivity is impractical, Table 14-1 gives approximate values of resistivity for different soil types. These values are only approximations and should be replaced by measured data whenever possible.

Table 14-1—Representative values of soil resistivities

Type of ground	Resistivity ($\Omega \cdot \text{m}$)
Wet organic soil	10
Moist soil	10^2
Dry soil	10^3
Bedrock	10^4

14.4.2 Fault current—magnitude and duration

Since shock hazard is a function of both time and current, a strictly rigorous ground mat analysis would require checking every possible combination of time and current. In practice, the worst shock hazard normally occurs at the maximum fault current. Determination of ground fault current and clearing time normally requires a separate system study. The techniques and problems of making fault studies are covered in numerous sources (including this book). Therefore, this section will only cover aspects peculiar to ground grid studies.

After the system impedance and grid resistance have been determined, the maximum ground fault current (assuming a bolted fault) is given as follows:

$$I = \frac{3V}{3R_g + (R_1 + R_2 + R_0) + j(X''_1 + X_2 + X_0)} \quad (14-6)$$

where

- I is the maximum fault current in amperes [note that this is not the same as the current in I_b in Equation (14-1)],
- V is the phase-to-neutral voltage in volts,
- R_g is the grid resistance to earth in ohms,

²Numbers in brackets correspond to those of the bibliography in 14.11.

- R_1 is the positive sequence system resistance in ohms,
- R_2 is the negative sequence system resistance in ohms,
- R_0 is the zero sequence system resistance in ohms,
- X''_1 is the positive sequence subtransient system reactance in ohms,
- X_2 is the negative sequence system reactance in ohms,
- X_0 is the zero sequence system reactance in ohms.

This current will, in general, be a sinusoidal wave with a dc offset. Since dc current can also cause fibrillation, the current value I must be multiplied by a correction factor called the decrement factor to account for this effect. Table 14-2 gives approximate values for this factor. For more accurate results, the exact value for the decrement factor D is given by the following equation:

$$D = \sqrt{\frac{1}{T}} \left[T + \frac{1}{\omega} \cdot \frac{X}{R} \left(1 - e^{-\frac{2\omega T}{X/R}} \right) \right] \quad (14-7)$$

where

- T is the duration of fault in seconds,
- ω is the system frequency in radians per second,
- X is the total system reactance in ohms,
- R is the total system resistance in ohms.

Table 14-2—Decrement factor for use in calculating electrical shock effect of asymmetrical ac currents

Shock and fault duration		Decrement factor
Seconds	Cycles (60 Hz)	
0.008	1/2	1.65
0.1	6	1.25
0.25	15	1.10
0.5 or more	30 or more	1.0

The current value calculated in Equation (14-6) must be multiplied by this factor to find the effective fault current. Note that the time T in Equation (14-7) is the same as that used in Equations (14-1), (14-4), and (14-5).

A common mistake in calculating ground mat current is to ignore alternate current paths. In most systems, only a portion of the ground fault current will return to the source through the earth. Because of the time and expense involved in running a full scale short-circuit study to accurately account for the division of fault current, the worst-case situation based upon the full short-circuit capability of the fault source is generally used.

To determine the fault duration, it is necessary to analyze the relaying scheme to find the interrupting time for the current calculated by Equation (14-6). The choice of the clearing time of either the primary protective devices or the backup protection for the fault duration depends upon the individual system. Designers must choose between the two on the basis of the estimated reliability of the primary protection and the desired safety margin. Choice of backup device clearing time is more conservative, but it will result in a more costly ground mat installation. Substitution of this time in Equations (14-4) and (14-5) will fix the maximum allowable step and touch potentials at the appropriate values.

14.4.3 Fault current—the role of grid resistance

In most power systems, the grid resistance is a significant part of the total ground fault impedance. Accurate calculation of ground fault currents requires an accurate and dependable value for the grid resistance. Equation (14-8) (taken from IEEE Std 80-1986) gives a quick and simple formula for the calculation of resistance when a minimum of design work has been completed.

$$R = \frac{\rho}{4r} + \frac{\rho}{L} \quad (14-8)$$

where

- R is the grid resistance to ground in ohms,
- ρ is the soil resistivity in ohm-meters,
- L is the total length of grid conductors in meters,
- r is the radius of a circle with area equal to that of the grid in meters.

The first term gives the resistance of a circular plate with the same area as the grid. The second term compensates for the grid's departure from the idealized plate model. The more the length of the grid conductors increases, the smaller this term becomes. This equation is surprisingly accurate and is ideal for the initial stages of a study where only the most basic data about the ground mat is available.

By inspecting Equation (14-8), it also becomes evident that adding grid conductors to a mat to reduce its resistance eventually becomes ineffective. As the conductors are crowded together, their mutual interference increases to the point where new conductors tend only to redistribute fault current around the grid, rather than lower its resistance.

Any computer program that can calculate the grid voltage rise can also calculate the grid resistance (with greater accuracy than the method described immediately above). The grid resistance is simply the total grid voltage rise (relative to a "remote" ground reference)

divided by the total fault current. In many cases, such programs perform this calculation automatically. This method can be applied to any grid configuration with any number of conductor elements. However, because the more advanced of these programs calculate grid voltages by solving hundreds of simultaneous equations, the same procedure is usually not practically achievable with hand calculations.

Since grid resistance is viewed as a measure of the grid's ability to disperse ground fault current, many designers are tempted to use resistance as an indicator of relative safety of a ground mesh. In general, however, there is no direct correlation between grid resistance and safety. At high fault currents, dangerous potentials exist within low resistance grids. The only occasion where a low grid resistance can guarantee safety is when the maximum potential rise of the entire grid (that is, grid potential) is less than the allowable touch potentials. In these cases, the ground mat is inherently safe.

14.4.4 Grid geometry

The physical layout of the grid conductors plays a major role in ground mat analysis. The step and touch potentials depend upon grid burial depth, length and diameter of conductors, spacing between each conductor, distribution of current throughout the grid, location of the grid with respect to a different resistivity soil layer, and proximity of the fault electrode and the system grounding electrodes to the grid conductors, along with many other factors of lesser importance. A perfectly rigorous analysis of all these variables would require both simultaneous linear and complex differential equations to exactly describe the distribution of current throughout the grid.

Historically, IEEE Std 80-1986 provides the only practical method for computing the effects of the grid geometry upon the step and touch potentials [Equations (14-9) and (14-10)].

$$E_{\text{mesh}} = K_m K_i \rho \frac{I}{L} \quad (14-9)$$

$$E_{\text{step}} = K_s K_i \rho \frac{I}{L} \quad (14-10)$$

where

- E_{mesh} is the worst-case touch potential at the surface above any individual grid area (i.e., "mesh") within the mat,
- E_{step} is the worst-case step potential anywhere above the mat,
- ρ is the soil resistivity in ohm-meters,
- I is the maximum total fault current in amperes (adjusted for the decrement factor)
- L is the total length of grid conductors in meters,
- K_m is the mesh coefficient,
- K_s is the step coefficient,
- K_i is the irregularity factor.

Coefficients K_m and K_s are calculated by two reasonably simple equations based upon the number of grid elements, their spacing and diameters, and the burial depth of the grid.

Because these equations do not take into account the many other factors that influence grid voltages, they are not meant to rigorously model a grid design, but are instead intended to make hand calculation of touch and step potentials feasible. Equations (14-9) and (14-10) incorporate an irregularity factor K_i to compensate for the inaccuracies introduced by these simplifying assumptions. Except for applications involving very simple grid configurations, proper selection of a value for K_i is dependent upon the experience and judgment of the designer. K_m and K_s can only be calculated for regular grid designs and must be estimated for irregular grid geometries. Most often, a high value picked for all these factors in the interest of conservatism usually results in an overdesigned mat. Conversely, there is no way to determine if the selected values are too low, resulting in an unsafe ground mat design.

The values of E_{mesh} and E_{step} calculated by Equations (14-9) and (14-10) must be compared to the tolerable touch and step potentials, $E_{\text{touch-tolerable}}$ and $E_{\text{step-tolerable}}$ as determined from Equations (14-4) and (14-5) in order to establish whether or not the design is safe. If, in fact, one of the tolerable voltage limits is exceeded, it is sometimes possible, by inspection of the grid, to determine mesh locations where additional cross-conductors should be added in order to achieve a safe design. The more general approach, however, is to uniformly increase the number of grid conductors.

Although this traditional hand calculation method for determining step and mesh potentials was considered acceptable in the past, modern ground mat studies normally use one of the new generation of computer programs. There are two types of computer programs available for ground mat studies. One type performs the aforementioned traditional hand calculations for empirically determining step and mesh potentials, but does it faster and more efficiently than possible by hand. The other type of program calculates the step and touch potentials for each individual grid (i.e., “mesh”) within the overall ground mat. The results, therefore, allow a more detailed analysis of ground mat design effectiveness, pinpointing any mesh locations where shock hazards may exist. The discussion that follows will concentrate on the latter of the two program types.

14.5 Advanced grid modeling

The key to an accurate ground grid analysis is the individual modeling of each single grid element, rather than the en masse treatment used in IEEE Std 80-1986. For example, Figure 14-3 shows a single grid element located at depth h below the earth’s surface in a homogenous medium. The element runs from point (x_1, y_1, z_1) to (x_1, y_2, z_1) and is radiating current to the surrounding earth at the linear current density σ_1 (the current per unit length). By integrating σ_1 over the length of the grid element, the current flux ξ can be found at any desired point (a) as follows:

$$\xi = \int_{y_1}^{y_2} \frac{\sigma_1}{4\pi} \frac{dy}{R^2} r \quad (14-11)$$

where

$$\begin{aligned} \xi & \text{ is the current per unit area at any point,} \\ \sigma_1 & \text{ is the current flowing to ground per unit length of conductor (current density),} \\ R & = \sqrt{(i-x_1)^2 + (j-y_1)^2 + (k-z_1)^2}, \\ r & = \frac{(i-x_1)i + (j-y_1)j + (k-z_1)k}{\sqrt{(i-x_1)^2 + (j-y_1)^2 + (k-z_1)^2}}. \end{aligned}$$

NOTE—For the purposes of illustration, Equation (14-11) shows a special-case expression that is only valid for lines running parallel to the y axis. The more general form is derived in the same manner, but is much more difficult to follow.

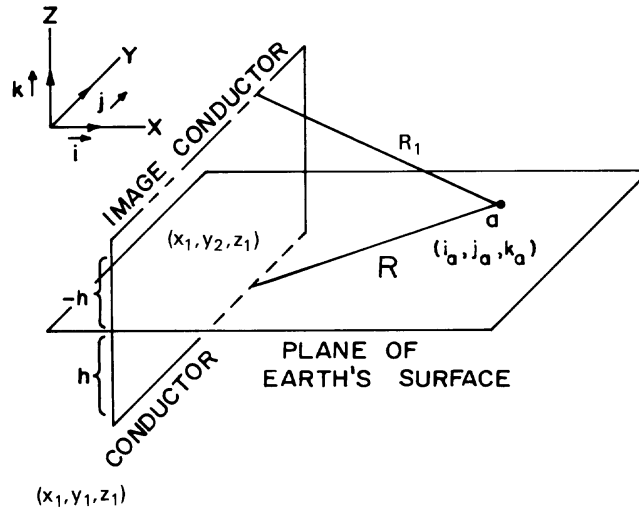

Figure 14-3—Physical model used in calculating voltage at point (a) due to a single conductor

Once ξ has been determined, the E field at the same point can be expressed as follows (assuming a homogeneous soil):

$$E = \rho \xi \tag{14-12}$$

where ρ is the soil resistivity.

From this, the voltage at point (a) can be obtained by performing the following integration:

$$V_{al} = -\int_{\infty}^a E \cdot dl \tag{14-13}$$

or

$$V_{a1} = \frac{\rho\sigma_1}{4\pi} \ln [j_a - y_2 + \sqrt{(i_a - x_1)^2 + (j_a - y_2)^2 + (k_a - z_1)^2}] \quad (14-14)$$

$$+ \frac{\rho\sigma_1}{4\pi} \ln [j_a - y_1 + \sqrt{(i_a - x_1)^2 + (j_a - y_1)^2 + (k_a - z_1)^2}]$$

where V_{a1} is the absolute potential at any point (a) due to line 1. This process must be repeated for every element in the grid.

NOTE—This process is complicated somewhat by the presence of the “current density” factor σ_1 in the equations. Although Equations (14-1) and (14-2) treat σ_1 as a constant, in actuality it varies continuously along the length of each grid element, as well as from element to element. In practice, the variation of σ_1 along the length of an element has little effect upon the calculated voltages, especially when calculating mesh potentials. The variation between elements is very significant, however, and must be obtained by solving a set of simultaneous equations. These can be written by using Equation (14-14) to calculate the voltage at known points (the surface of each grid element, for example). When the variation of current density along an element is important, it can be approximated by modeling the element as several segments, each with its own value of σ_1 .

Finally, the individual contribution of each grid element can be summed to determine the total voltage at point (a).

An extension of this same basic approach involving multiple images of each conductor is used to perform calculations for multilayer (typically two layer) soils (Dawalibi and Mukhedkar [B7] and Joy, Meliopoulos, and Webb [B13]). The number and complexity of the equations that must be solved is greater, but they can be readily managed using the computer solution methods.

The advantages of this analytical method are immediately apparent. This technique automatically accounts for the finite length of each element, a particularly important consideration when finding the potential at points near the end of an element. It can handle grid designs with large degrees of asymmetry with no sacrifice in accuracy. In cases involving multilayer soils, the effect of the resulting redistribution of currents within such soil systems (Dawalibi and Mukhedkar [B7]) on touch and step potentials is accurately quantified. Furthermore, since point a can be located anywhere and any number of points can be examined, detailed analysis of the grid design is possible.

The grid layout also determines which points should be checked for touch and step potentials. Touch potentials are normally calculated at the mesh centers, at control stations (where operators may be present), at the entrances to the facility, and at the corners of the grid. Step potentials are rarely a problem inside the grid. However, they may be a danger in the areas just outside the grid, such as the exterior of a perimeter switchyard adjacent to the fence. The worst step potentials usually occur along a diagonal line at the corners of a grid (see Figure 14-4). Shock hazard voltages can be accurately determined at all such critical locations using these calculating procedures. In addition, the absolute (earth) surface potentials and the ground potential rise (EPR) of the grid is an automatic by-product.

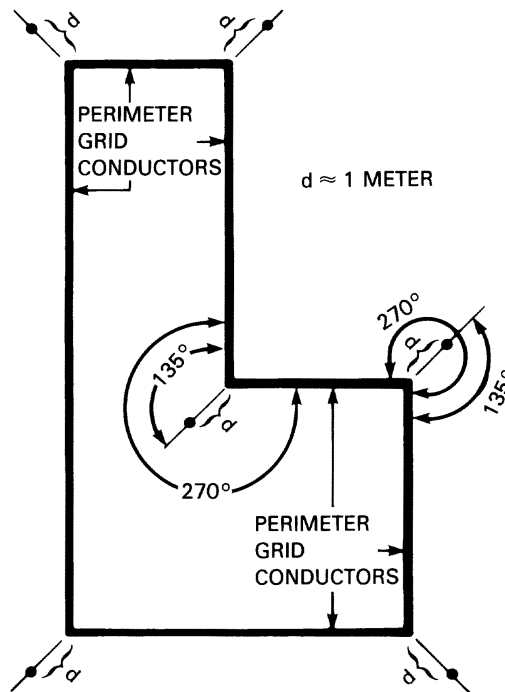
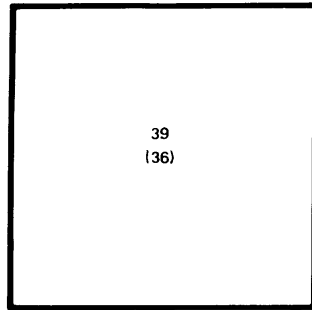

Figure 14-4—Typical ground mat layout showing possible locations of critical step and touch potentials near grid corners

14.6 Benchmark problems

Every analytical procedure (including computer programs) needs to be checked against a benchmark problem. Figure 14-5 shows six different grid layouts where the mesh potentials were measured on small scale models. Measured results from these configurations are the best available benchmark information for ground mat analysis programs. The calculated voltages (expressed as a percentage of the grid voltage) are shown in the center of each mesh. For easy reference, the actual measured voltages are also shown in parentheses. For this analysis, a program calculated the absolute voltage at the center of each mesh. In an actual ground mat study, the calculated point voltages would be subtracted from the calculated grid potential to determine the touch potential hazard. Figure 14-5 (especially grids E and F) illustrates the accuracy of the program. Errors are typically on the order of 5%, and never worse than 10%.

The most impressive feature of this type of program, however, is its ability to calculate voltages at any point of interest within or around the mat's geometric boundaries. By repeated use of the program throughout the design process, a ground mat layout can be fine-tuned to achieve the desired protection without the need to overdesign any section of the mat.



GRID A

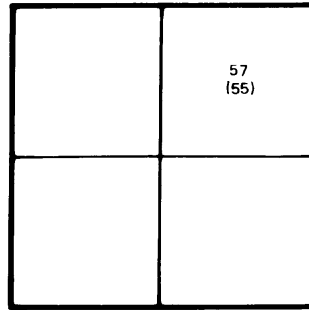

GRID B

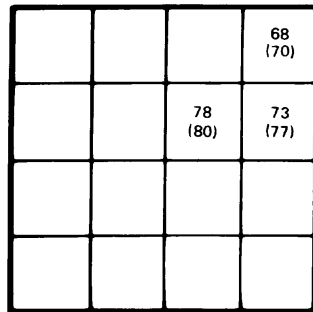

GRID C

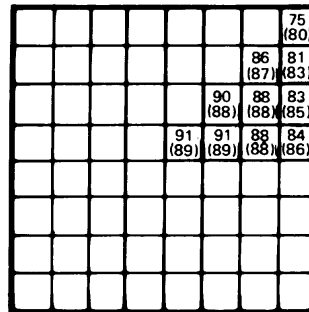

GRID D

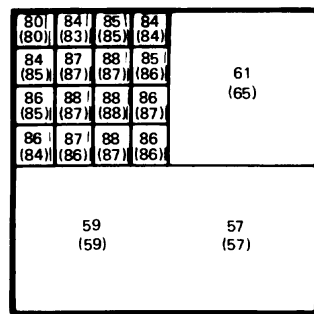

GRID E

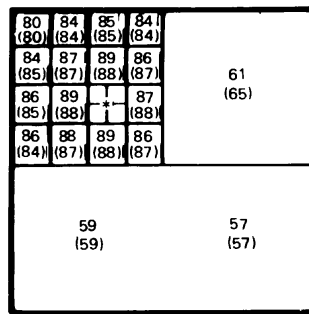

GRID F

NOTE: Values shown are center of mesh voltages expressed as a percent of total grid voltage rise above remote ground.
with () = test results
without () = computer calculated

95	95
(93)	(93)
95	94
(93)	(93)

Figure 14-5—Experimental grids showing various (mesh) arrangements

14.7 Input/output techniques

The increased use of personal computers in the workplace has led to higher expectations for all software. Ground mat analysis programs are no exception. Since the grid layout is so important to this class of programs, they are especially well suited to graphical input/output methods. First generation programs typically required the user to input the end coordinates of each grid element, and simply printed the calculated voltages at user-designated coordinates. Figure 14-6 shows a typical output report from an early ground mat analysis computer program (in this particular case, grid E of Figure 14-5). Although the basic calculations are correct, interpretation is difficult and checking the data entry is laborious and time-consuming.

Most modern ground-mat analysis programs support some form of graphical output, either two-dimensional or three-dimensional, as illustrated by Figures 14-7, 14-8, and 14-9. Many programs allow the user to draw the grid design and then calculate the endpoints internally. With proper preparation, others are capable of reading the grid design directly from CADD drawing files. Some programs can select the points to calculate automatically or plot equipotential lines. Ground mat programs can also do material take-offs as well as material and labor cost estimates. The latest programs not only calculate raw voltages, they compute the mesh and touch potentials and compare them to the limits (also automatically calculated). New programs can also manage multiple surface materials and soil layers. They can also store intermediate calculations for later use. Advanced programs can edit their input data, ignoring unimportant detail. Figure 14-11 shows a graphical output from a typical ground mat analysis program of recent vintage. The conductor arrangement shown affords a ground mat design that has a 5% minimum safety margin.

14.8 Sample problem

Figures 14-10 through 14-13 demonstrate the use of a ground mat analysis program on a typical ground mat design in a homogeneous soil. Figure 14-10 shows the grid layout and all pertinent data along with the mesh design resulting from application of the traditional hand calculating procedures described in 14.4.4. Figure 14-11 gives the results of a computer analysis of the grid clearly indicating that grid corners and certain perimeter meshes are unsafe using these procedures. Figures 14-12 and 14-13 show the results of modified grid designs. Note that in Figure 14-13 the amount of additional grid conductor required to safely control mesh potentials in the grid has been minimized and that the use of the computer program has permitted the location of this conductor to be optimally determined (that is, the conductor has been added only where required). This is the great advantage of a computer ground mat analysis.

14.9 Conclusion

The adaptation of classical analytical techniques and calculating procedures to the digital computer has made ground mat analysis much more precise, reliable, and useful. Many ground mat analysis programs can all but eliminate unnecessary grid overdesign and, if

GROUND GRID VOLTAGE STUDY		EXAMPLE PROBLEM FIGURE 161, GRID E									
RESISTIVITY = 1000.0											
FAULT CURRENT (AMPERES)		500.		1000.		4000.					
GRID COORDINATES (MILLIMETERS)		VOLTAGE									
		A = ABSOLUTE POTENTIAL				B = TOUCH POTENTIAL					
		A	B	A	B	A	B	A	B	A	B
(30.0,	30.0)	1372.	951.	2743.	1902.	10973.	7610.				
(90.0,	30.0)	1307.	1016.	2613.	2032.	10453.	8129.				
(90.0,	90.0)	1418.	905.	2836.	1809.	11344.	7238.				
(7.5,	67.5)	1984.	339.	3968.	678.	15871.	2711.				
(7.5,	82.5)	1975.	348.	3950.	696.	15798.	2784.				
(7.5,	97.5)	1942.	381.	3883.	762.	15534.	3048.				
(7.5,	112.5)	1851.	472.	3701.	944.	14805.	3777.				
(22.5,	67.5)	2015.	307.	4031.	615.	16123.	2459.				
(22.5,	82.5)	2023.	300.	4046.	599.	16184.	2398.				
(22.5,	97.5)	2001.	322.	4001.	644.	16005.	2577.				
(22.5,	112.5)	1936.	387.	3871.	774.	15484.	3098.				
(37.5,	67.5)	2019.	304.	4037.	608.	16150.	2432.				
(37.5,	82.5)	2032.	291.	4064.	582.	16254.	2328.				
(37.5,	97.5)	2016.	307.	4032.	614.	16128.	2454.				
(37.5,	112.5)	1963.	360.	3926.	720.	15702.	2880.				
(52.5,	67.5)	1981.	342.	3961.	684.	15846.	2736.				
(52.5,	82.5)	1975.	348.	3950.	696.	15800.	2782.				
(52.5,	97.5)	1960.	363.	3920.	726.	15679.	2903.				
(52.5,	112.5)	1931.	392.	3862.	784.	15447.	3136.				
GRID POTENTIAL		2323.		4646.		18582.					

NOTE: GRID IS 120×120 MILLIMETERS, ORIGIN (0,0)
IS LOCATED AT LOWER LEFT CORNER.

**Figure 14-6—Sample output report—
Computer calculated ground grid potentials**

properly applied, *all* ground mat analysis programs can detect unsafe conditions that might otherwise go undiscovered until made apparent by serious mishap.

A ground mat study requires, as a minimum, the following data:

- Soil resistivity, both at the level of the grid and (if appropriate) at any other soil layer
- Resistivity of any special soil surface dressing material
- Estimated duration of a ground fault
- System frequency

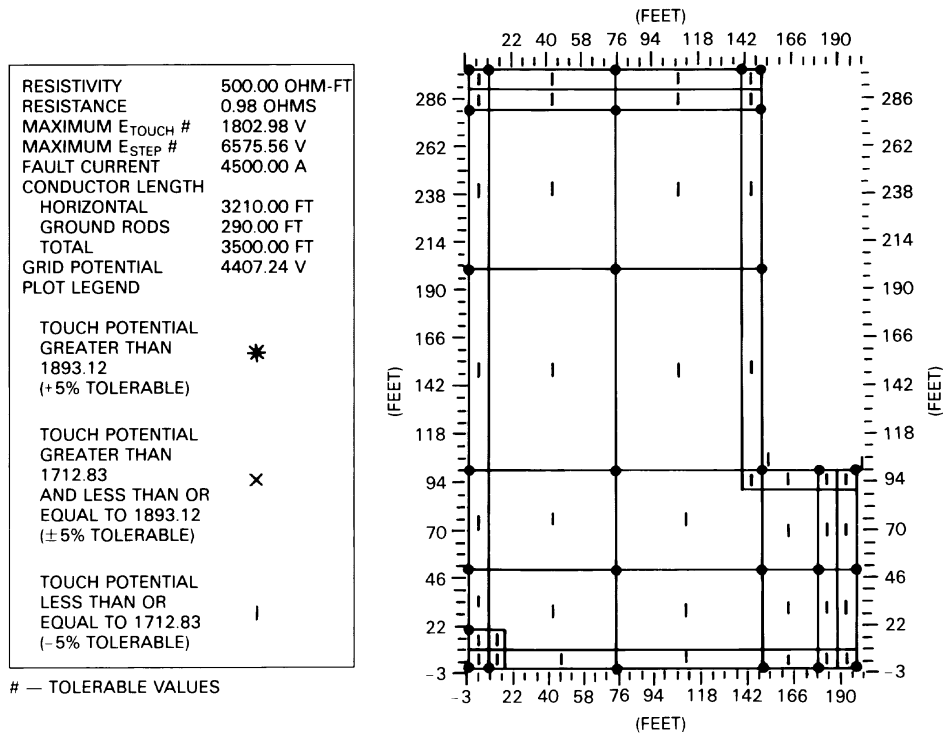

Figure 14-7—Sample computer generated graphical output report for a typical ground mat analysis

- System *X/R* ratio
- Maximum symmetrical ground fault current, both future and present
- Grid layout showing the precise location of every conductor
- Coordinates where the potential rise must be calculated

Consideration of all this information will lead to a reliable, accurate, and useful study.

Two basic types of ground mat computer programs have been discussed. When considering the purchase or use of such programs, it first must be determined what level of analytical accuracy is required and, accordingly, which type of calculating method is desired—either the traditional empirical method discussed in 14.4 of this chapter or the detailed mesh-by-mesh method described in 14.5 through 14.8. Care should be taken to select a program that is appropriate for the application chosen.

Although ground mat analysis programs provide an invaluable design tool, they are by no means infallible. If at all possible, a followup investigation should be made of each grid after it has been installed. This should include a measurement of grid resistance at the very least,

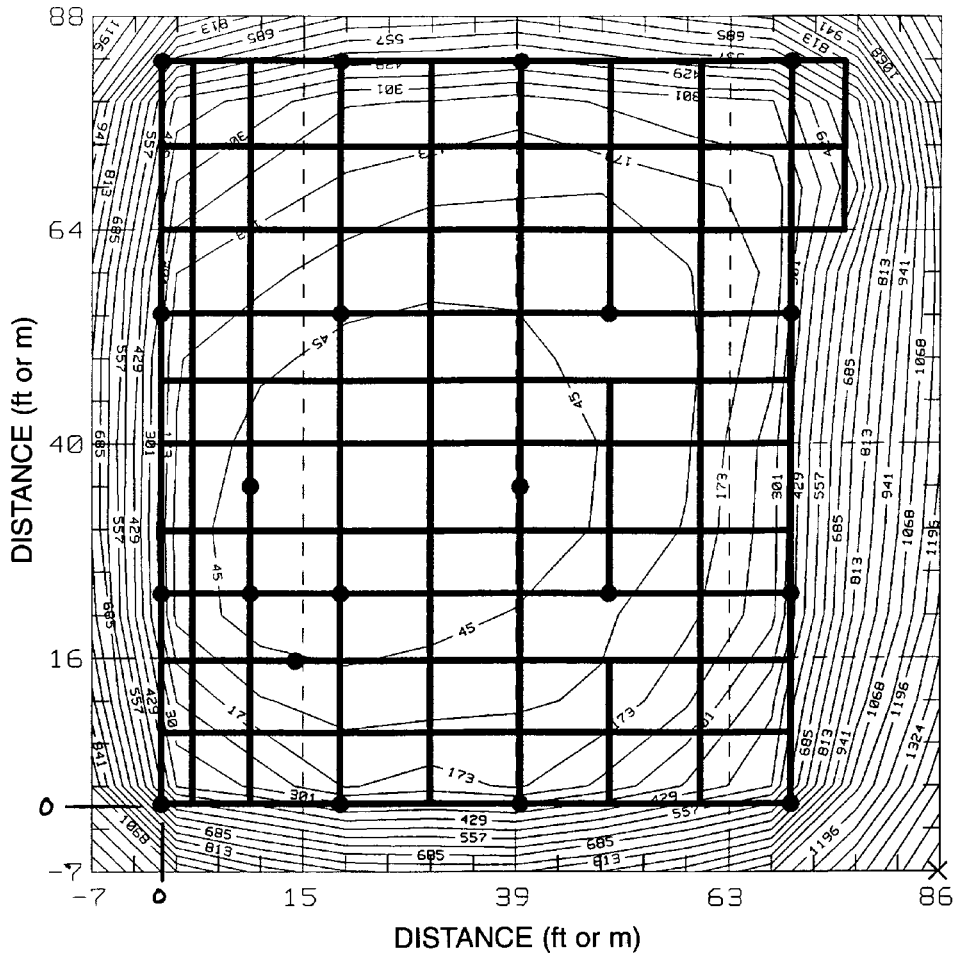

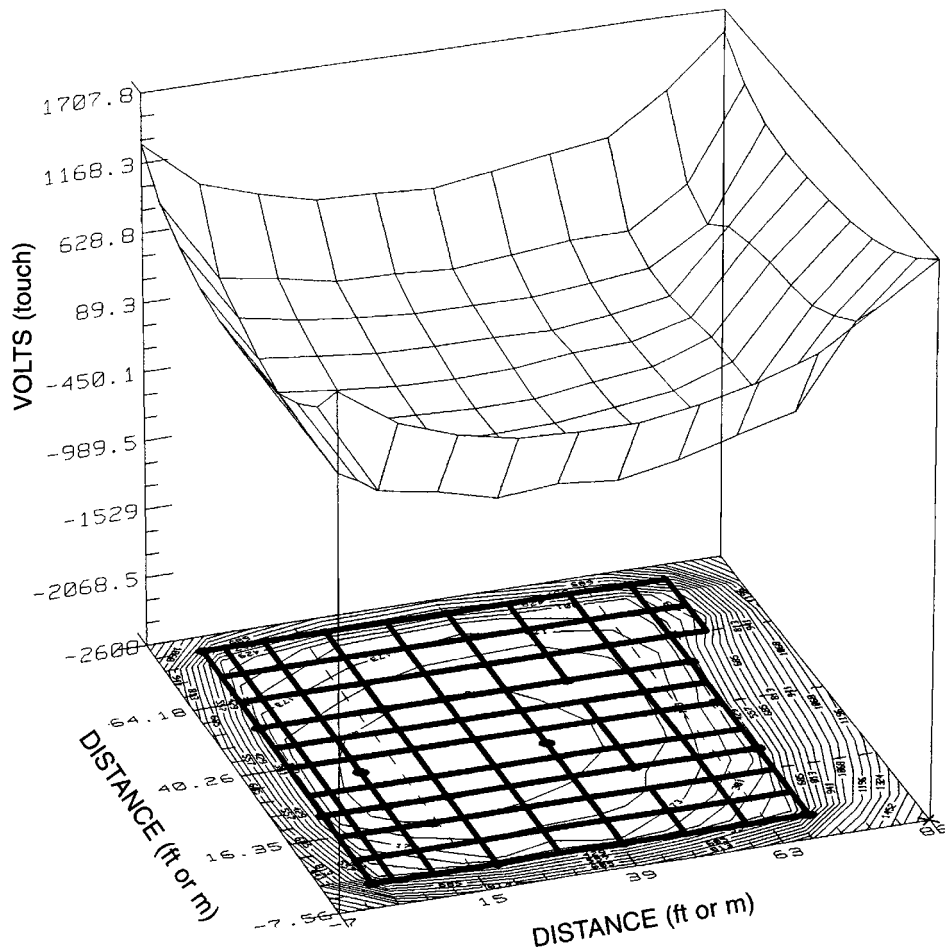

Figure 14-9—Sample 3-dimensional program graphical output showing equipotential plots of touch voltage at earth's surface above mat

14.11 Bibliography

[B1] Dalziel, C. F., "Dangerous electric currents," *AIEE Transactions*, vol. 65, pp. 579–585; 1123–1124.

[B2] Dalziel, C. F., "Threshold 60-cycle fibrillating currents," *AIEE Transactions*, vol. 79, pp. 667–673, 1960.

[B3] Dalziel, C. F., "A study of the hazards of impulse currents," *AIEE Transactions*, vol. 72, pp. 1032–1043, 1953.

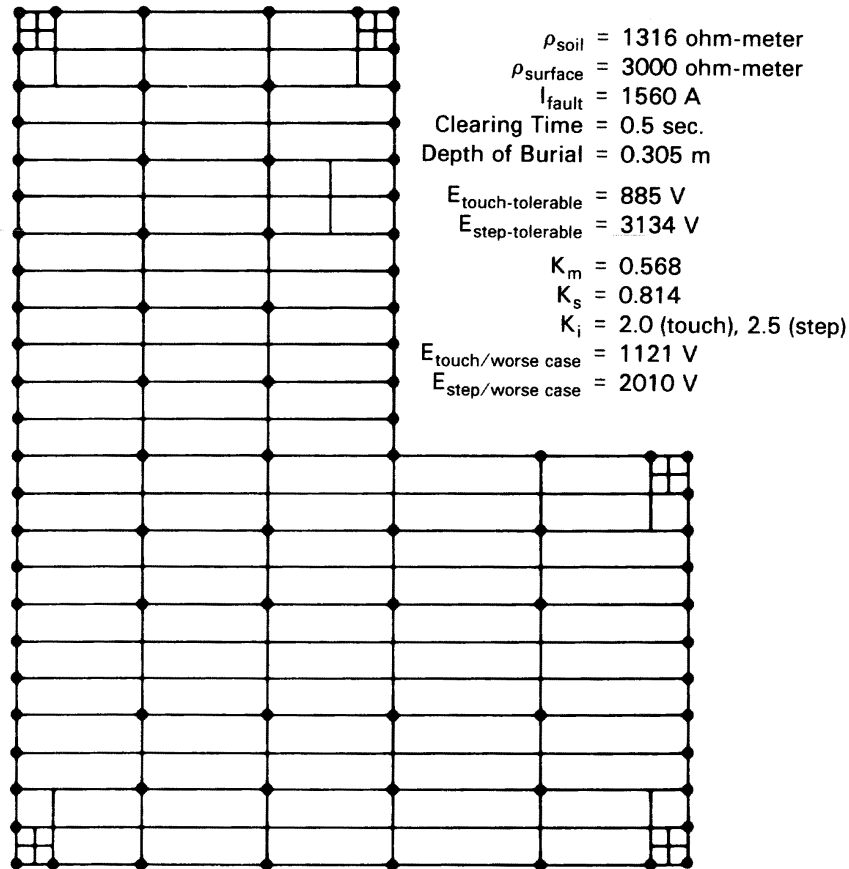

Figure 14-10—Typical ground mat design showing all pertinent soil and system data

[B4] Dalziel, C. F., and Lee, W. R., "Re-evaluation of lethal electric currents," *IEEE Transactions on Industry General Applications*, vol. IGA-4, pp. 467–476, Sept./Oct. 1968.

[B5] Dawalibi, F., and Mukhedkar, D., "Multi-step analysis of interconnected grounding electrodes," *IEEE Transactions on Power Applications Systems*, vol. PAS-95, pp. 113–119, Jan./Feb. 1976.

[B6] Dawalibi, F., and Mukhedkar, D., "Optimum design of a substation grounding in a two-layer earth structure," *IEEE Transactions on Power Applications Systems*, vol. PAS-94, no. 2, pp. 252–272, Mar./Apr. 1975.

[B7] Dawalibi, F., and Mukhedkar, D., "Parametric analysis of grounding grids," *IEEE PES Winter Meeting*, Paper No. F79243-7, 1979.



Figure 14-11—Typical ground mat design showing meshes with hazardous potentials as identified by computer analysis

[B8] Ferris, L. P., King, B. G., Spence, P. W., and Williams, H. B., “Effect of electrical shock on the heart,” *AIEE Transactions*, vol. 55, pp. 498–515 and 1263, May 1936.

[B9] Geddes, L. A., and Baker, L. E., “Response to passage of electric current through the body,” *Journal of the Association for the Advancement of Medical Instruction*, vol. 2, pp. 13–18, Feb. 1971.

[B10] Gross, E. T. B., Chitnis, B. V., and Stratton, L. J., “Grounding grids for high-voltage stations,” *AIEE Transactions*, vol. 72, pp. 799–810, 1953.

[B11] Gross, E. T. B., and Hollitch, R. F., “Grounding grids for high-voltage stations—III, resistance of rectangular grids,” *AIEE Transactions*, vol. 75, pt. III, pp. 926–935, 1953.

[B12] Gross, E. T. B., and Wise, R. B., “Grounding grids for high-voltage stations—II,” *AIEE Transactions*, vol. 74, pt. III, pp. 801–809, 1955.

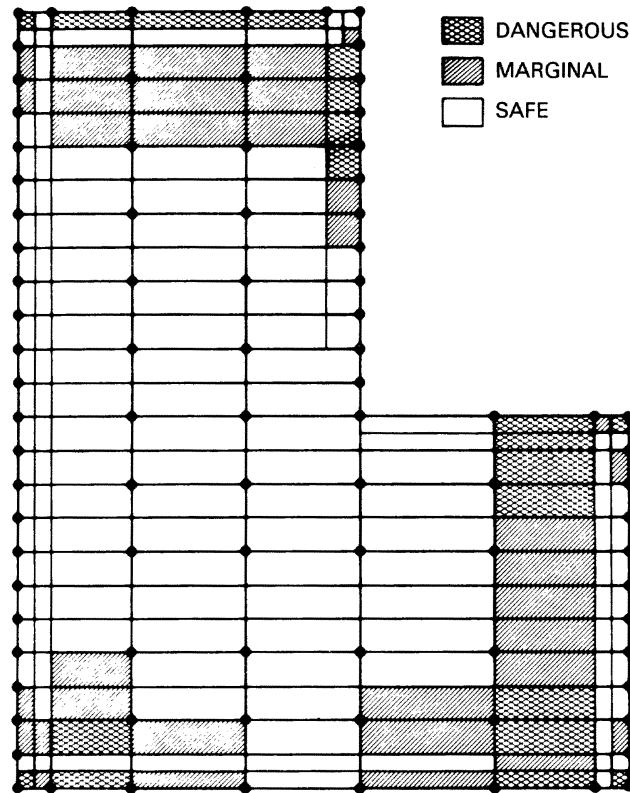

Figure 14-12—Typical ground mat design, first refinement showing meshes with hazardous touch potentials

[B13] Joy, E. B., Meliopoulos, A. P., Webb, R. P., “Touch and step calculation for substation systems,” *IEEE PES Winter Meeting*, Paper No. A79052-2, 1979.

[B14] Koch, W., “Grounding methods for high-voltage stations with grounded neutrals,” *Electrotechnische Zeit*, vol. 71, no. 4, pp. 89–91, 1950.

[B15] Laurent, P., “General fundamentals of electrical grounding techniques,” *Bulletin de la Société Française des Electriciens*, vol. I, series 7, pp. 368–402, Jul. 1951.

[B16] Niemann, J., “Changeover from high-tension grounding installation to operation with a grounded star point,” *Electrotechnische Zeit*, vol. 73, no. 10, pp. 333–337, May 15, 1952.

[B17] Rudenberg, R., “Grounding principals and practice I—fundamental considerations on ground currents,” *Electrical Engineering*, vol. 64, pp. 1–13, Jan. 1945.

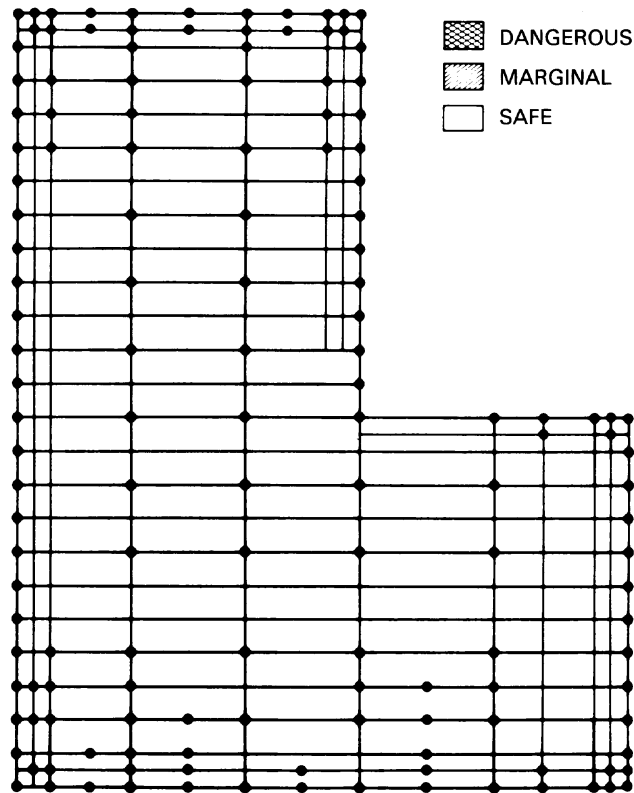

Figure 14-13—Typical ground mat design, final refinement with no hazardous touch potentials

[B18] Schwartz, S. J., “Analytical expression for resistance of grounding system,” *AIEE Transactions*, vol. 73, pp. 1011–1016, 1954.

[B19] Sunde, E. D., “*Earth Conduction Effects in Transmission Systems*,” New York: Van Nostrand, 1949.

Chapter 15

Coordination studies

15.1 Introduction

An important step in the design of any power distribution system is the time-current coordination of all overcurrent protective devices required for the protection of the system and the connected equipment. When a short circuit or an abnormal power flow occurs for a sustained period of time, the protective devices should react to isolate the problem with minimum disruption to the balance of the system. This is the goal of a well-coordinated electrical power system.

The reader should be aware that this chapter addresses only one aspect of system protection: overcurrent protection. For most large, medium-voltage systems, overcurrent protection acts only as backup for primary protection and, as such, this chapter is not a complete study of system protection. The operation of protective devices can be estimated by graphic representation of the time-current characteristics curves (TCCs) of these devices. By plotting these characteristics on a common graph, the relationship of the characteristics among the devices is immediately apparent. Any potential trouble spots, such as overlapping of curves or unnecessarily long time intervals between devices, are revealed. By indicating on the current scale the maximum and minimum value of short-circuit currents (three-phase and line-to-ground) that can occur at various points in the circuit, the operation of circuit protective devices can be estimated for various fault conditions. An accompanying single-line diagram can indicate the components and define their location in the circuit.

The time-honored method of plotting these curves, as illustrated in Figure 15-1, is to superimpose a transparent sheet of graph paper over the manufacturer's published curves on an illuminated drafting table. When the time scales have been carefully matched and the current scales adjusted, the curve is traced onto the graph paper using a French curve or flexible spline. The process is then repeated for the remaining protective devices. Damage curves for equipment, such as motors, transformers, and cables, are also plotted to assess the level of protection provided for the equipment and to provide a graphical representation of the protection achieved. This process can be both tedious, time consuming, and prone to error.

Since the selection of device parameters follows well-defined rules, for the most part, computer programs are available for the task of producing these curves. Some programs will select the settings necessary to achieve a well-coordinated system as well as plotting curves and related data.

The application of the computer and computer software to time-current coordination studies is a viable alternative to the manual approach. With the availability of dependable hardware for digitizing, plotting, computing, and communicating with a computer, time-current coordination studies using these tools are a practical alternative that is now possible. Device settings and ratings may be calculated and tabulated. The TCC drawings may be displayed on

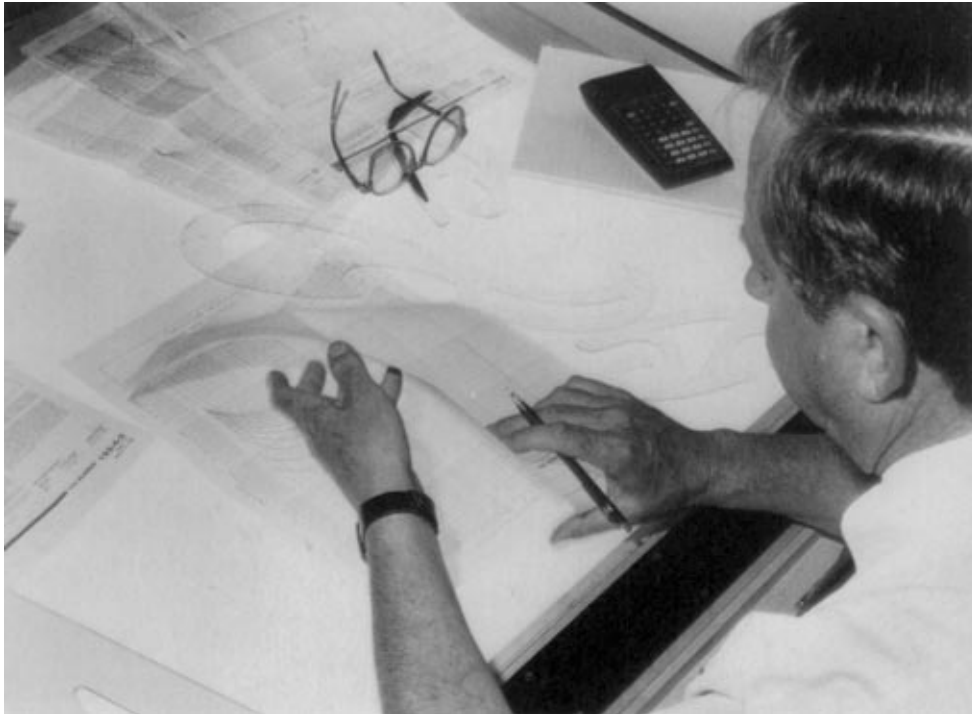

Figure 15-1—Manual method of producing time-current curves by using a light table

graphic monitors, and the output reports may be routed to graphical printers and plotters. The popular K&E form 48-5258 may be used as a plot background, when desired.

15.2 Basics of coordination

Whether the coordination is done manually or by computer, it is necessary for the engineer to “describe” the system. The information needed to perform a coordination study is a single-line diagram showing the following:

- Protective device manufacture and type
- Protective device ratings
- Trip settings and available range
- Short-circuit current at each system bus (three-phase and line-to-ground)
- Full load current of all loads
- Voltage level at each bus
- Transformer kVA, impedance, and connections (delta-wye, etc.)
- Current transformer (CT) and potential transformer (PT) ratios
- Cable size, conductor material, and insulation
- All sources and ties

Figure 15-2 shows a section of the single-line diagram presented in Chapter 1 (Figure 1-1) with protective devices and other information added using the normal conventions employed for coordination studies. Figure 15-3, which is a copy of Figure 5-26 in IEEE Std 141-1993 [B1],¹ shows a coordination study with a manually drawn plot. Figure 15-4 uses the same single-line diagram and shows the study done by a computer program.

Information is needed regarding the time-current characteristics of the devices in the circuit. Traditionally, this information is in the form of manufacturer's TCC curves on 11 in by 17 in, 4-1/2 by 5 cycle log-log paper. When coordination is performed on a computer, this information is stored in a device data file or "library."

The coordination can start at the farthest downstream device but coordination must exist with the utility's last protective device and the plant's main protective device. It is in this area, at the very least, where engineering judgment is required in order to achieve the best coordination. The downstream device is sketched with a characteristic and setting that allows full-load current to flow and prevents tripping for transient and normal overload conditions. The device immediately upstream is next, with its characteristics and settings selected to satisfy the specified current requirements and to coordinate with the downstream device. This procedure is followed for each device either by use of a light table or a grid on transparent paper and shifting and sketching or by giving the information to the computer and allowing it to show the coordination. When a transformer is encountered, the impedance, connection, and rating are needed to properly select settings and ratings of upstream devices. A typical procedure for organizing data before beginning a coordination study by computer is as follows:

- a) Note motor horsepower, full load current, acceleration time, and locked rotor current.
- b) For each protective device: note short circuit current, full load current, and voltage level at each device. List device manufacturer and type, and program file name for device.
- c) For each low-voltage breaker, indicate long time, short time, instantaneous. Note settings if existing device.
- d) For each fuse, note rating.
- e) For each relay, note tap range, CT ratio, tap and time dial, if known, and whether relay has instantaneous.
- f) For each transformer, note kVA, fan cooled rating, impedance, and transformer connection.
- g) For cable damage curves: note cable size, conductor material, and cable insulation.

The engineer, when working on a coordination study, either manually or by computer, will encounter situations in which there are devices of a specific size or settings that cannot be adjusted, or when other constraints make it impossible to obtain perfect coordination. In a situation such as this, the design engineer must make a compromise judgment, based on his or her training and experience. The ability to try various settings to determine the best coordination must be a feature of any computer program.

¹The numbers in brackets correspond to those of the bibliography in 15.9.

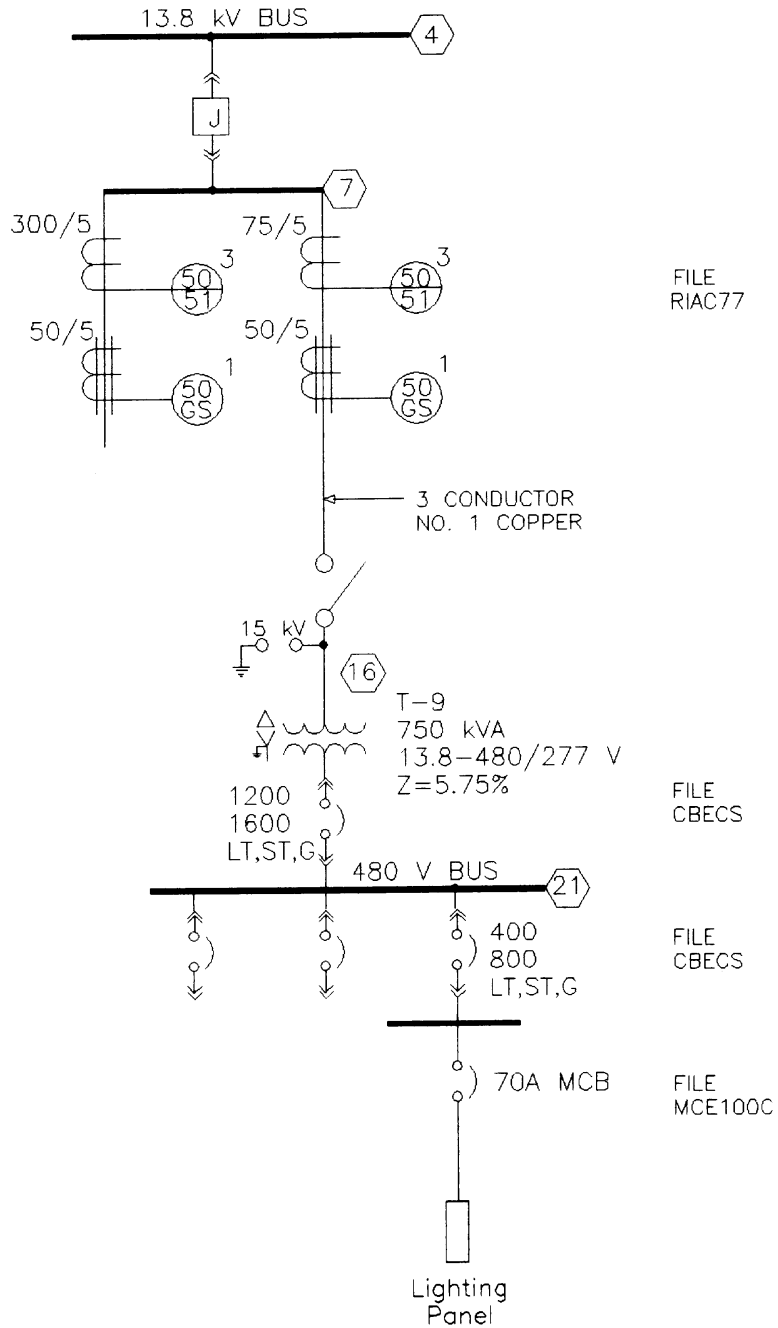
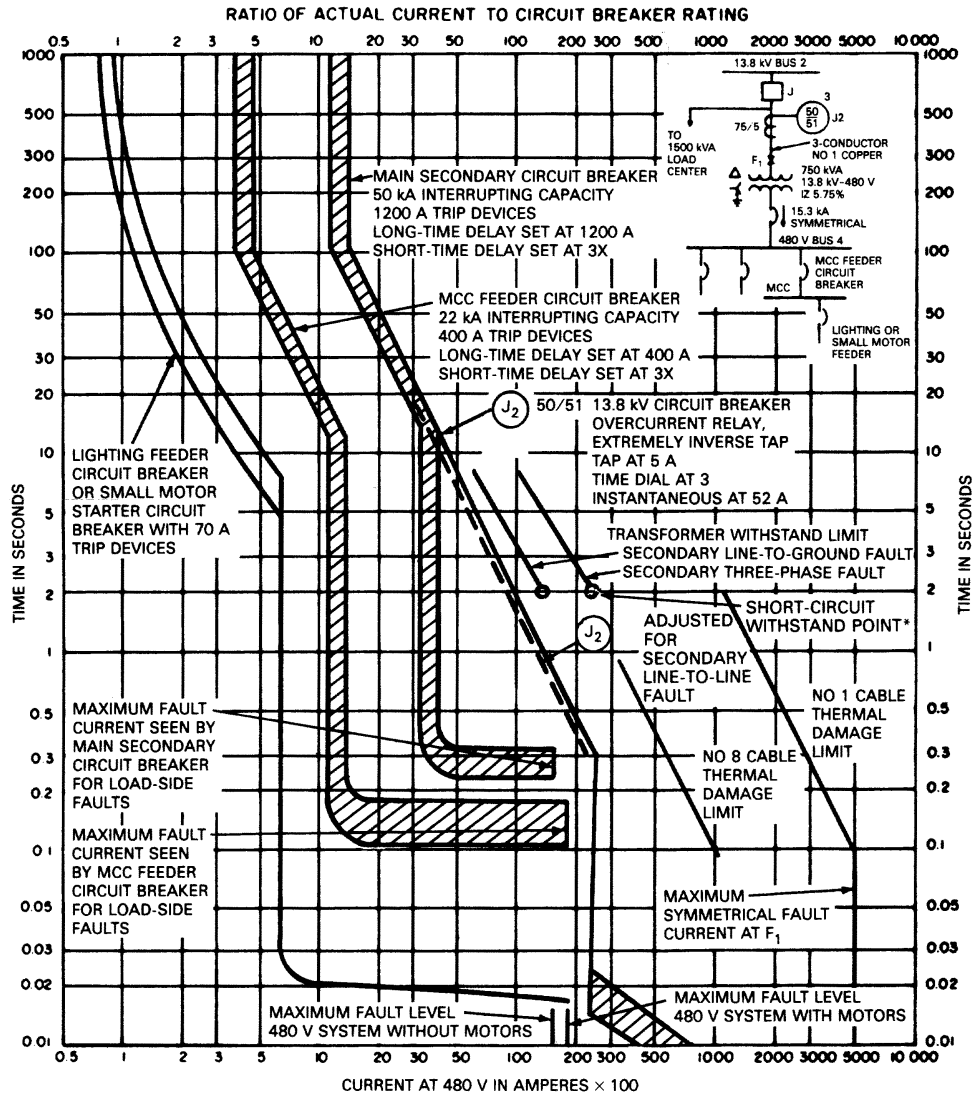

Figure 15-2—Single-line diagram showing notations relative to coordination



*As defined in ANSI C57.12.00-1973, which has been superseded by IEEE C57.12.00-1993.

Figure 15-3—Manually produced time-current curve

Once the phase overcurrent coordination study is made, a ground-fault current coordination study should be performed using separate plots because of different fault current levels. The results of the ground fault coordination study should be compared with the phase overcurrent protection to verify the coordination.

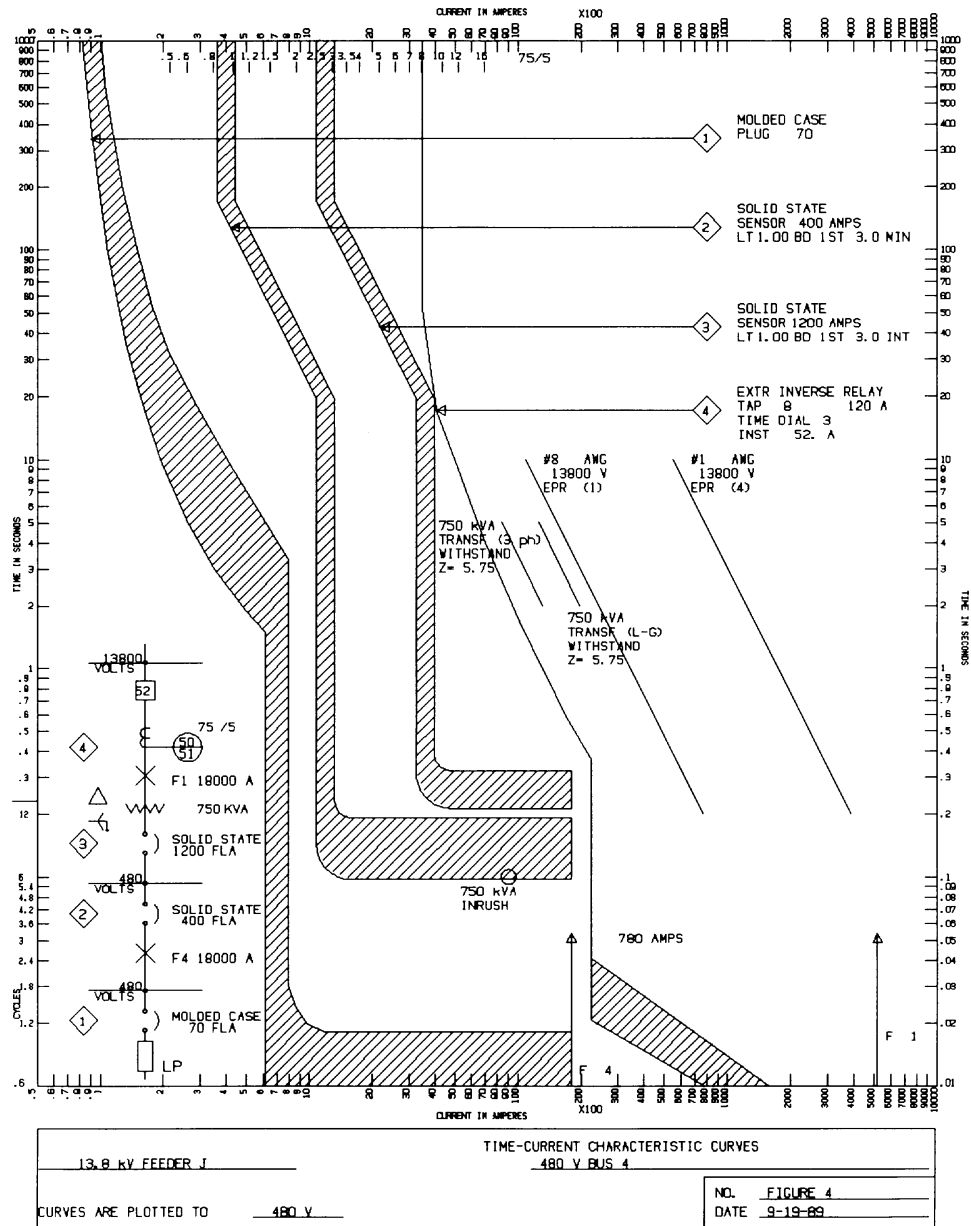

Figure 15-4—Computer-produced time-current curve plotted on a printer

15.3 Computer programs for coordination

Several types of computer programs for the coordination of circuit protective devices are available to the design engineer. For some time to come, this area is expected to be a rapidly changing technology. For purposes of illustration, two types of programs will be introduced. One type of program is designed to select circuit breaker trip settings, overcurrent relay tap and time dial settings, and fuse ratings and to plot the TCC curves on the standard 4-1/2 by 5 cycle format. The second type stores the data, makes it accessible to the user, but does not automatically perform the coordination. It produces the plot based on the settings chosen by the engineer as would be done manually.

15.3.1 Coordination programs

Coordination programs perform setting and rating selections, unless these items are input by the user. In such programs, the time-current characteristic data for various manufacturers' fuses, relays, and circuit breakers must be stored. Ratings and settings are selected by the program to satisfy the stated input conditions. The engineer must accept the responsibility of reviewing the selections and making the final determinations in any coordination study.

Such programs may include the necessary logic to calculate and plot transformer inrush and withstand as well as cable damage and motor-starting curves. When there is a motor in the system, the program will select the setting of the first device to ensure that it will not trip on motor starting and will provide the commands to plot the curve. From that point on, the program will perform the coordination based upon the type of device used and the parameters built into the program for clearance with downstream devices using accepted coordination criteria for separation between curves.

Programs that perform the coordination are usually structured so that any device parameter may be specified by the user. If the settings are input, the program may not perform the usual checks for that device, since the logic of the program may be based on the assumption that the user is aware of what he or she is doing. With this method, the engineer may add one device at a time and view it before continuing, or may input the entire set of data before viewing it on a graphics screen.

With this type of program, information on the type of device selected may be available for use in developing and plotting the single-line diagram.

15.3.2 TCC plotting programs

The second type of coordination program is the type that provides a library for drawing coordination curves and other features usually shown on a TCC curve. The same type of plot can be obtained as in the first coordination type by having the user enter the settings and ratings and construct the curves using the library files. All decisions associated with the selection of device settings are performed by the engineer. These programs may include the logic for calculating and plotting transformer inrush and withstand, cable damage, motor-starting curves, and one-line diagrams.

15.4 Common structure for computer programs

The primary task of the protective device coordination computer program is to permit the engineer to produce coordination studies that are similar to the studies that would be created using manual techniques.

A well-structured program will contain features to model various types of protective devices and equipment damage characteristics and to store these characteristics in a device library. The program should be able to call these devices from the library and to accurately reproduce the manufacturer's curves on the graphic output device. In addition, the program should generate documentation of the studies including output reports indicating the device settings and single-line diagrams indicating the elements of the power system described on the TCC drawing.

15.4.1 Project data base files

A data base is a method by which the program stores the information contained in the study. Ideally, the data base will be structured to hold all of the information on all of the devices located in the power system. Coordination studies usually consist of a number of different TCC drawings. A single device, say a main breaker, may be shown on more than one drawing. Keeping the characteristics of the devices in specified groups will eliminate duplicate data entries for displaying the same device on a second or third drawing. This data base structure will eliminate the possibility of plotting the same device with different settings on different drawings.

15.4.2 Interactive data entry

The selection of the devices is normally an interactive procedure whereby the program prompts the user for the designation and description of the devices to be used. It is common for the program to display information on all the devices in the library when requested by the user.

Regardless of whether the program is the type that performs the coordination, the type that gives the engineer the choice of entering his or her own settings, or the type that does both, rapid feedback of the information to the engineer via the computer monitor is important. Viewing the screen should provide enough accurate information so that a paper copy is not necessary until the coordination process is complete.

The program should provide the engineer the capability of modifying data, by changing plotting voltage, current setting, or any device parameter, and immediately viewing results. Features to zoom into areas of the display and directly measure time intervals between device operating characteristics should be available.

Figure 15-5 shows an engineer zooming a plot on the screen to determine which area needs to be examined in more detail.

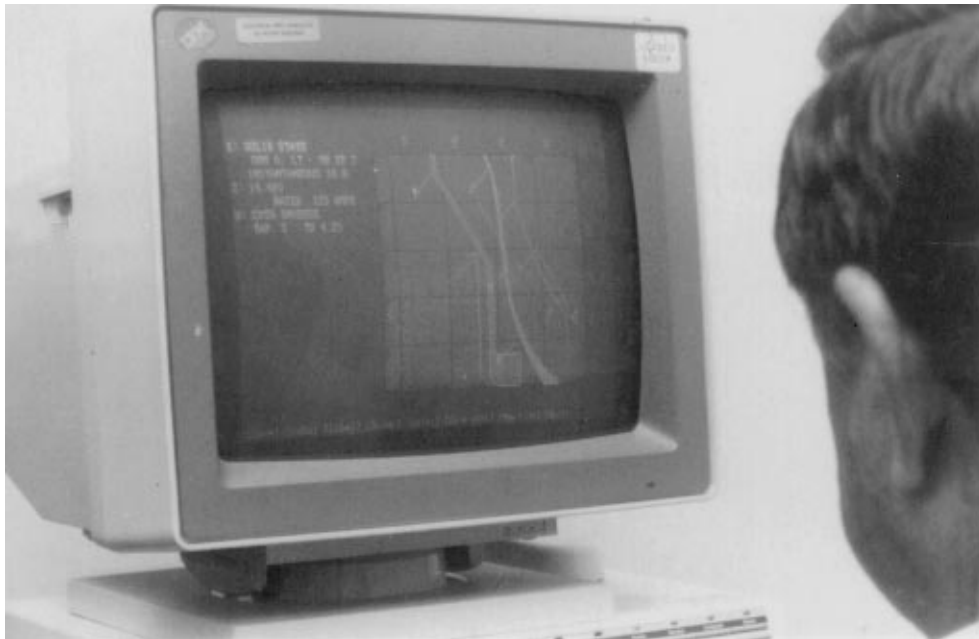

Figure 15-5—Engineer shown viewing a CRT monitor while using the computer method

15.4.3 User-defined libraries

The program should provide for a user-defined device library. Protective devices, when not available in the program library, are modeled by the engineer using some type of digitizing procedure, mathematical modeling, or a combination of the two. Since many output devices cannot draw curves, curves are simulated by the software as very short straight lines.

For some types of protective devices, mathematical modeling is preferred. For example, the solid-state trip device for a low-voltage circuit breaker may have literally thousands of possible settings. It is not practical to store each of these as individual digitized curves in the data base. Mathematical modeling can accomplish this task with a minimum of data.

15.4.4 Single-line diagram generator

To assist in documentation for the study, the program should include some means of generating a single-line diagram. One method of accomplishing this is to have the software automatically generate the single-line diagram as the devices are entered. With other programs, the single-line diagram may be developed using computer-aided design and drafting (CADD) software. The CADD software may be included with the coordination software. Some programs produce graphic commands that may be used with popular CADD systems, so that the single-line diagram may be added or enhanced with the software residing on the computer.

15.4.5 Graphics monitor

Most software has provisions to view the coordination study on a graphics monitor before requesting a plot on the printer or plotter. Some method should be provided with the screen plot so that the engineer can determine if the results of the coordination are satisfactory and can accurately establish the clearance between devices. An opportunity to modify, add, or delete devices should be available. Figures 15-6, 15-7 and 15-8 show the input screen for three programs.

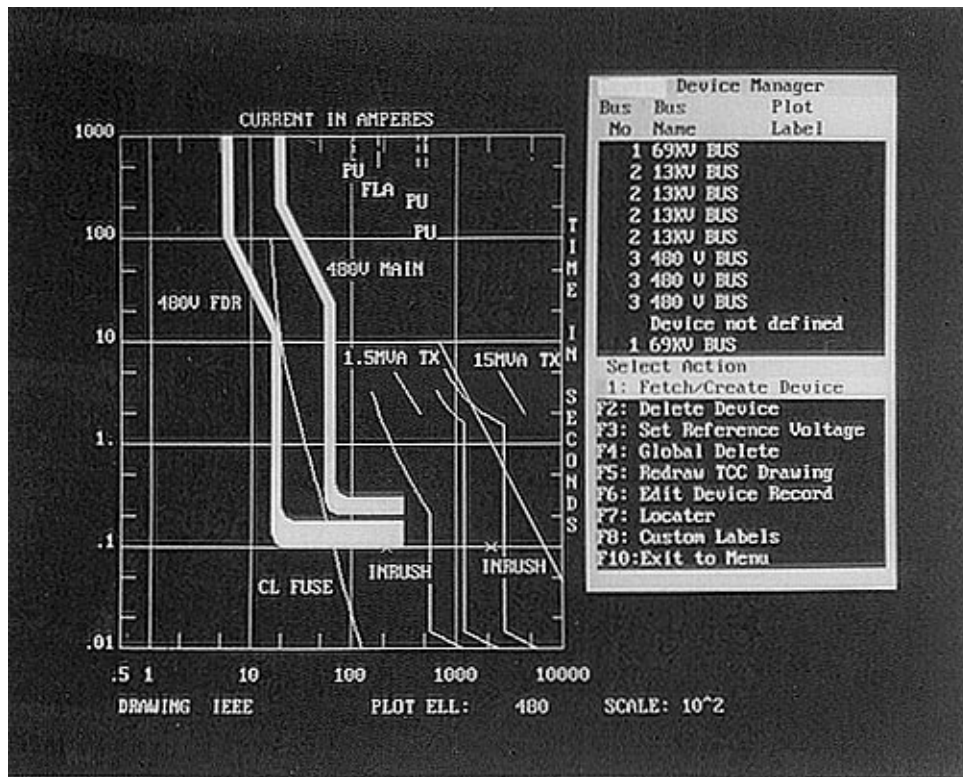

Figure 15-6—Example of screen plot

15.4.6 Plotter/printer graphical interface

In today's computer environment, the engineer is able to select from a wide range of graphic display plotters and printers. Programs are normally written to use plot drivers so that the software will be able to support a wide range of hardware. Plot drivers are programs that translate the data from the internal computer representation to a form usable by the plotting hardware.

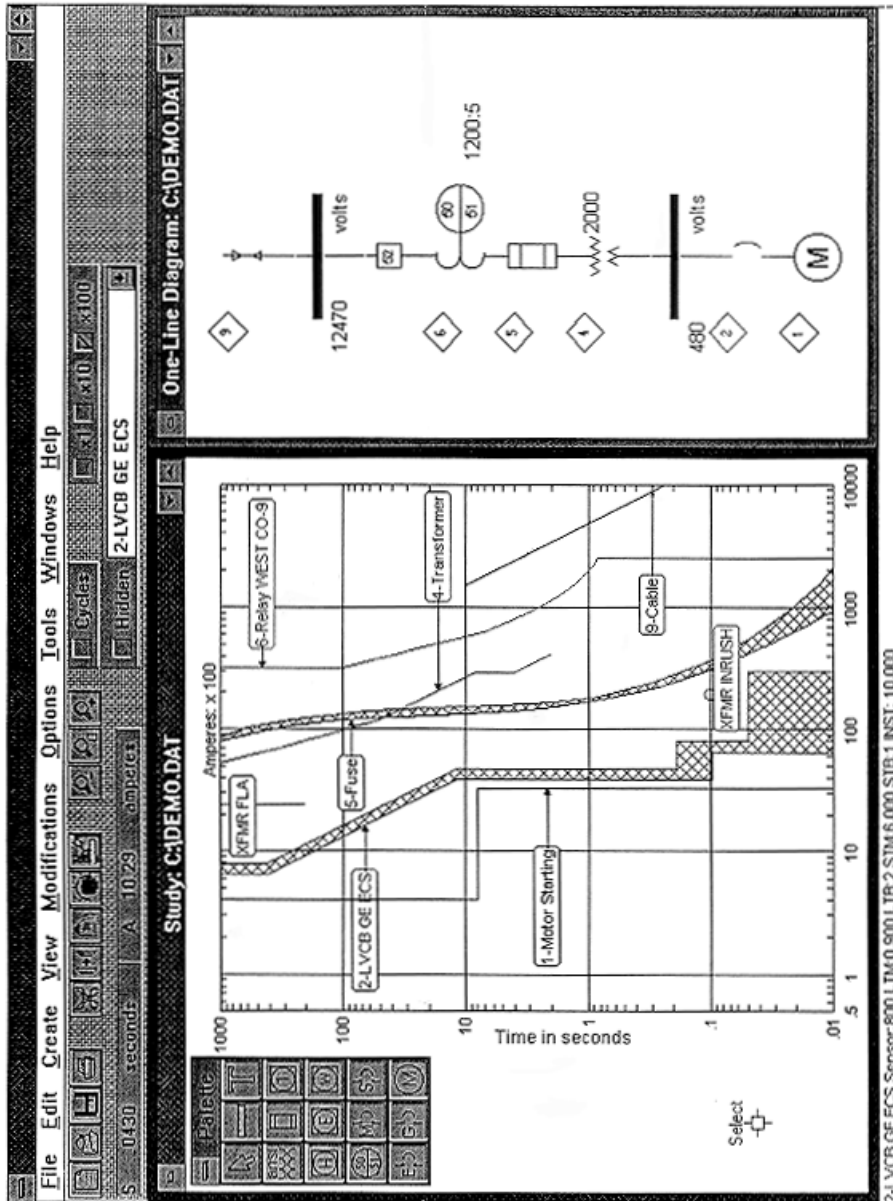

Figure 15-7—Example of screen plot using the latest PC technology

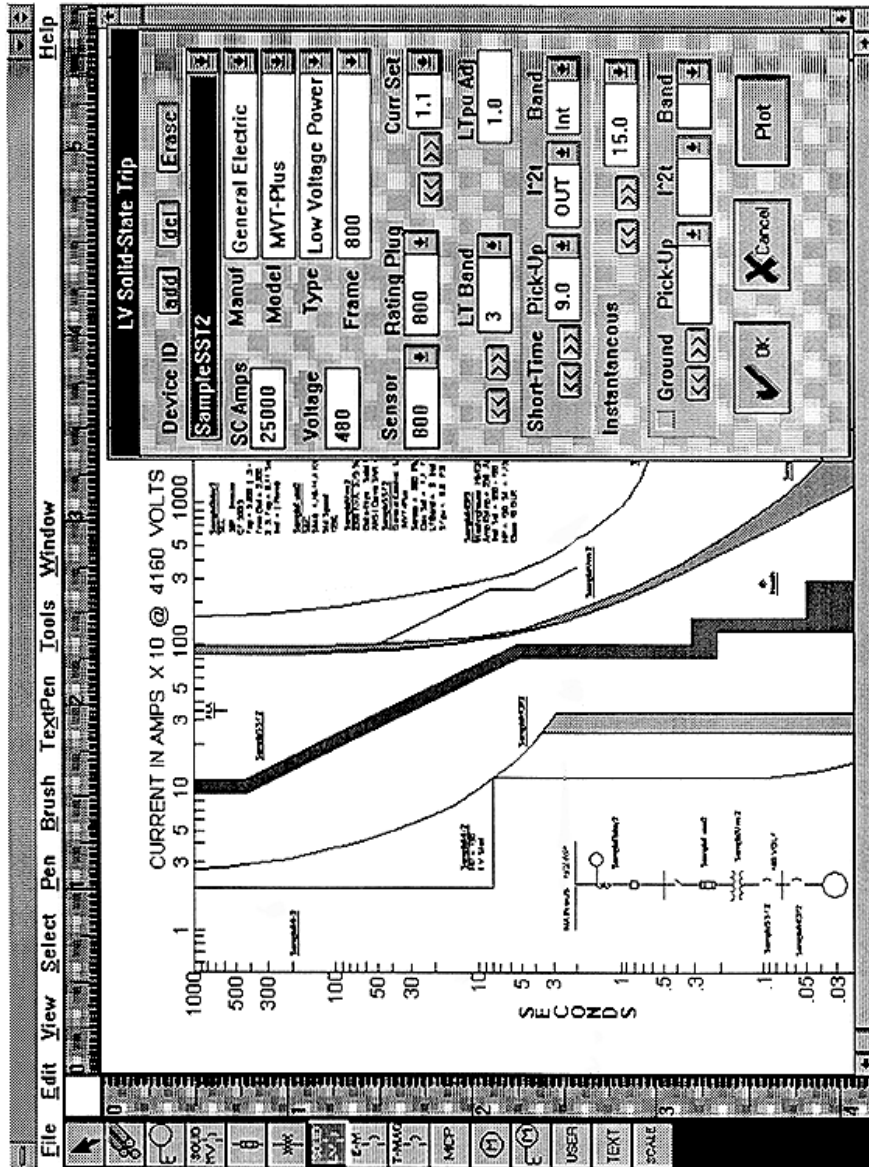

Figure 15-8—Example of how the light table of Figure 15-1 has been replaced by the computer screen “light table”

Software is used to provide the output format of the data that the graphics software sends to the plot driver. The use of this method permits a single program to support most types of hardware without modification of the basic software package. Such programs permit the engineer to upgrade hardware without fear that the software will become obsolete.

15.4.7 Graphical output reports

The computer program should be capable of producing the TCC drawings in a wide range of formats on a wide range of graphical output devices. As a minimum, the software should be able to produce the drawings on a 4 1/2 by 5 cycle K&E form 48-5258 pre-printed log-log paper. Figure 15-9 shows such output.

Most computer programs support graphical output to both printers and plotters. Features are provided for the engineer to specify if the software is required to generate a background grid. Pen colors and fill patterns may also be an option available to the user. Figure 15-4 is a plot produced by a printer.

15.4.8 Device setting report generator

The software should contain provisions for reporting the device settings and ratings of all devices. These reports may be sent to a printer when desired.

15.5 How to make use of coordination software

There are various ways that an engineer can make use of existing coordination software, depending on the type of equipment that is used for computing and plotting, the frequency of program use, and the money invested in the program. With the increase in the number of personal computers (PCs; see 15.5.1), use of the programs on a main frame computer has become obsolete. Coordination software is typically used with a PC, either in-house or through a consultant or manufacturer. A description of equipment needs, cost, and advantages or disadvantages follows in 15.5.1 and 15.5.2.

15.5.1 Personal computers (PCs)

Engineering departments have purchased PCs, which are single-user, stand-alone computers that sit on (or under) the desk of the engineer. This type of computer provides engineering departments better control over and flexibility in their computing chores. Time-current coordination programs are available for these computers. Display graphics is an important feature common to this type of computer and, with low-cost graphic printers and desktop plotters, results of the studies may be quickly generated.

Early PCs suffered from a lack of random access memory (RAM) and a limited amount of permanent data storage capacity. There have been very rapid technical enhancements in hardware and computer operating systems so that engineers have very powerful PCs with large memory and high speed readily available.

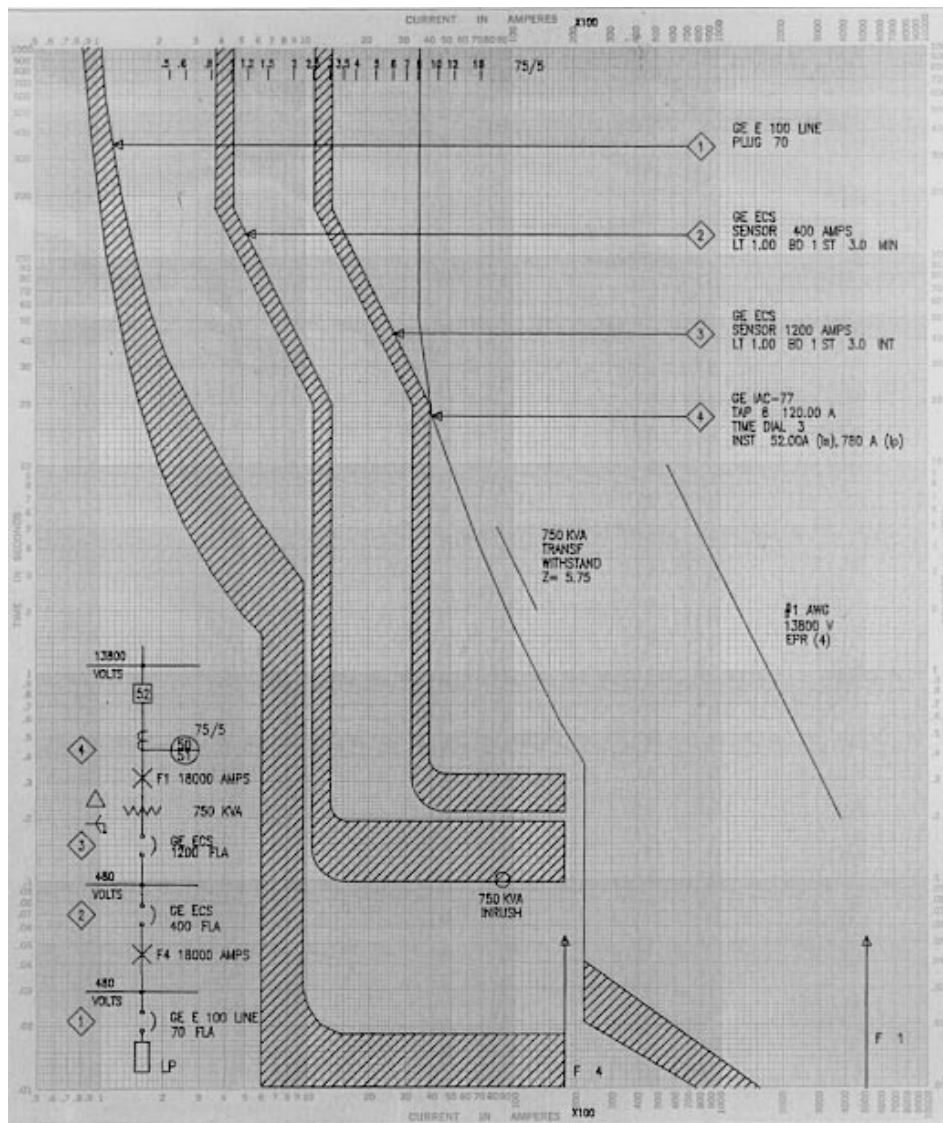

Figure 15-9—Example of plot on K&E 48-5258 form

PCs offer all firms, large and small, the opportunity to use advanced software. PCs offer engineers the opportunity to examine many design alternatives in no more time than a manual analysis would have taken.

An additional use of the PC is as a storage device for coordination curves. Storing the 11 in by 17 in forms is often done haphazardly and, when one is needed, can be hard to find. When the curves are created on the computer, the data can be copied to a floppy, if hard disk space is

short. This disk can then be stored and, when a copy of the curve is needed, it can be printed again. Some companies are using the computer to “replot” old curves and store the information to be available when needed

15.5.2 Consulting service

Some manufacturers will provide coordination studies (usually for a fee) for customers using their equipment. Often, their device libraries are limited, particularly on existing devices of another manufacturer.

Consulting firms who have purchased or written a coordination program are another source for having the studies done. Consulting engineers develop experience with these programs. The time-current curves can often be produced more cost-effectively by a consultant familiar with the program in cases in which the company would need to add and/or train manpower. There is a learning curve with any new program and, if the knowledge will not be used on a continuing basis, it is often better to let someone else do it. Also, consultant’s experience in performing coordination studies can provide important “know-how” and expertise that may be required, especially when complex power systems and circuit arrangements are involved.

15.6 Verifying the results

Whether the coordination is performed by computer or manually, the engineer needs to have confidence in the results. Checking the computer plot may be difficult since often the engineer does not have a copy of the manufacturer’s curve. When it is available, it is often plotted to a different scale, making it difficult to compare. Ideally, the program should have a method for plotting out the entire family of fuse or relay curves at a scale and in a manner that permits comparison to the manufacturer’s curves. For example, for any fuse, there would be a plot of all the minimum melt curves and a plot of all the total clearing curves. Software vendors may be willing to supply these plots along with copies of the manufacturer’s curves to the engineer for verification. Plots could also be made for low-voltage circuit breakers for specific settings for direct comparison with the manufacturer’s curves.

15.7 Equipment needs

A computer with hard drive and monitor, a plotter and/or a printer are required to run most programs.

Before purchasing equipment, the supplier of the software should be contacted for information. The required hardware configuration may vary with the software being purchased. Particular attention should be given to the minimum conventional memory requirements of these programs and compatibility to specific LAN environments.

15.8 Conclusion

The increased popularity of the computer and its availability in most engineering facilities has resulted in liberating the design engineer from the tedious task of manually drawing coordination curves, thereby allowing him or her to be free to design. With the use of simplified input of interactive software, even those engineers who have an inherent fear of computers can become confident. The engineer is still needed to make those critical judgment decisions and to establish the criteria that should not be left to a computer. With state-of-the-art coordination software, the engineer is no longer required to struggle with the mundane tasks of manually drawing curves and tabulating results.

15.9 Bibliography

Additional information may be found in the following sources:

[B1] IEEE Std 141-1993, IEEE Recommended Practice for Electric Power Distribution for Industrial Plants (IEEE Red Book).

[B2] IEEE Std 242-1986 (Reaff 1991) IEEE Recommended Practice for Protection and Coordination of Industrial and Commercial Power Systems (IEEE Buff Book).

Chapter 16

DC auxiliary power system analysis

16.1 Introduction

Attention concerning the reliable operation of dc electrical power systems (e.g., emergency standby power supplies used for generating stations, data processing facilities, long-distance telephone companies, etc.) has steadily increased in recent years. This has increased the role of the dc systems engineer by not only requiring in-depth dc power systems analysis, but keeping that analysis up to date. The recent introduction of computer techniques to dc power systems analysis allows more rapid and rigorous analysis of complex problems in comparison with earlier manual techniques.

This chapter discusses two primary aspects of performing dc power systems analysis (load flow and short-circuit) including system modeling, developing the appropriate one-line diagram for the power system of interest; including source bus, branches and loads. A one line diagram from a representative system is used for illustrating the examples.

16.2 Purpose of the recommended practice

Several standards, guidelines, and technical papers exist that provide guidance to dc power systems analysis. These documents are available through various standards organizations (i.e., IEEE, UL, NEMA, etc.) and manufacturers. Many of these sources treat the subject with the assumption that hand calculations are being performed. It is the intent of this chapter to consolidate this information and provide guidance for performing dc power systems analyses.

16.3 Application of dc power system analysis

As with ac industrial and commercial power systems, the planning, design, installation, and operation of dc electrical power systems require engineering studies to evaluate existing and proposed system performance, reliability, safety, and economics. For new systems, studies can ensure proper sizing of equipment such as batteries, chargers, distribution equipment, etc. For existing systems, studies can aid in improving system reliability by identifying weaknesses within the system and providing the recommended design for system improvement.

DC systems are becoming increasingly complex, making studies more difficult and time-consuming. The recent introduction of software specifically designed for analysis of dc power systems greatly simplifies computational tasks that have traditionally been done by hand.

The elements of dc power systems analysis that are essential to ensuring an adequate dc system include the following:

- a) *System modeling*. Sources, branches, and loads
- b) *Load flow/voltage drop*. During battery discharge and motor starting
- c) *Short-circuit*. Peak, time constant, rate of rise, and steady-state
- d) *Battery sizing*. See IEEE Std 485-1997 [B8]¹
- e) *Charger sizing*. See IEEE Std 946-1992 [B9]

16.4 Analytical procedures

With the development of the digital computer and advanced programming techniques, dc power system problems of the most complex types can be rigorously analyzed. An engineer involved in the creation or modification of dc power systems analysis programs must thoroughly understand the application of the basic analytical solution methods used. It is equally important for those who assemble and prepare data for input to a dc power systems analysis program, as well as those who interpret and apply the results generated by such a program to understand the basic analytical solution methods.

Some of the analytical procedures utilized on dc systems are very similar to the procedures presented in Chapters 3 and 4 for use with ac systems. In fact, for steady-state conditions on dc systems it is possible to obtain reasonable approximations by carefully manipulating resistance or reactance values in load flow or short-circuit software designed for analysis of ac power systems.

The remainder of this chapter will cover the analytical procedures specific to dc systems which are not covered in Chapters 3 and 4.

16.5 System modeling

The normal dc system analysis process begins with preparation of a system one-line diagram similar to Figure 16-1. The actual values for the load and branch information to be modeled are added as the diagram is developed. The completed one-line diagram with all of the cable resistances and source/load models included is often referred to as an impedance diagram. A separate impedance diagram showing the connected impedances, sources, and loads is sometimes prepared for each system being analyzed.

For steady-state load flow/voltage drop studies the inductances are ignored and a resistance diagram results. For transient load flow/voltage drop studies the inductance values cannot be ignored.

¹The numbers in brackets correspond to those of the bibliography in 16.9.

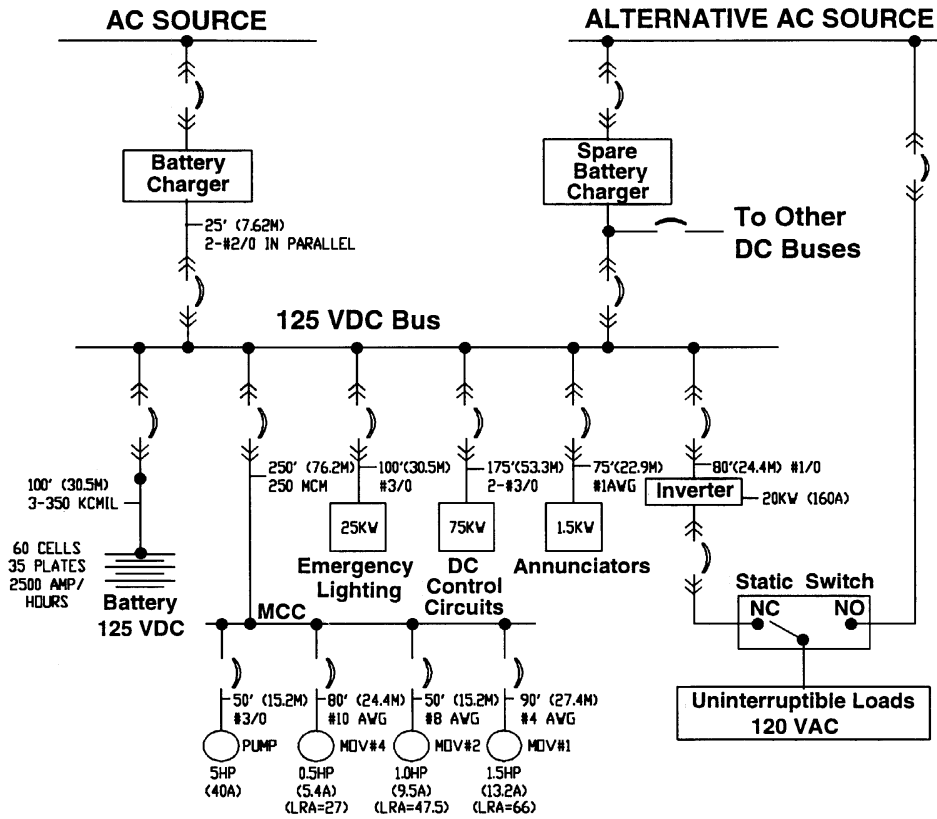

Figure 16-1—Sample dc one-line diagram

Load flow/voltage drop and short-circuit studies are usually performed with different conductor temperatures assumed. Therefore, the resistance portion of the one-line diagrams for these two types of studies are typically not identical.

When developing the one-line diagram, each component should be represented as the equivalent model necessary for the study. Components commonly modeled are sources, branches, and loads. Sources include batteries, chargers, power converters (rectifiers), generators, and motors (for short-circuit studies). Branches include wire, cables, bus duct, protective devices, and combination starter units (contactors and thermal overload devices). Loads include motors, relay coils, solenoid valves, lamps, inverters, and dc/dc power supplies. The basic considerations for modeling the three general component classes are presented herein.

Most loads can be adequately modeled as having a constant resistance, constant power, or constant current characteristic. Correctly categorizing the loads is absolutely essential if load flow/voltage drop studies are to provide useful results.

Constant resistance loads draw a current that is directly proportional to the load terminal voltage (load current falls as terminal voltage falls). Heaters, relays, solenoid valves, some motors, and most lamps fall into the category of constant resistance loads.

Constant power loads draw a current that is inversely proportional to the load terminal voltage (load current rises as terminal voltage falls). Inverters, dc/dc power supplies, and many motors fall into this category.

Constant current loads draw essentially the same current for a wide range of input voltages. Some dc power supplies (i.e., shunt regulated supplies) draw a constant current. Some motors (most notably, valve actuator motors) can be most accurately modeled as constant current loads rather than constant power.

If a load's characteristic is unknown, it is usually conservative to model it as constant power for load flow/voltage drop studies. This is because the current rises as load terminal voltage falls, which tends to amplify the effects of voltage drop, producing a lower (usually worse) terminal voltage at the load.

As stated above, steady-state load flow calculations do not require inductance values. Short-circuit calculations require inductance values for all elements only if the short-circuit time constant and rate of rise are to be calculated in addition to the peak and steady-state short-circuit current values. The various circuit elements will be discussed in the following order: sources, loads, and branches. Load flow system modeling will be discussed first, followed by short-circuit system modeling in each clause.

After the sources, loads, and branches have been modeled, the data from the models and the one line are typically entered into a computer program to perform the required analyses.

16.5.1 Battery characteristics

16.5.1.1 Voltage during discharge

Battery voltage begins to decline as soon as discharge begins. There is an initial drop in voltage due to the ohmic resistance of the battery and chemical action within the battery. This abrupt drop in voltage is usually followed by a slight rise in voltage (the coup de fouet effect) as the diffusion process allows fresh electrolyte to come in contact with the plates. Thereafter, the voltage resumes its decline. The voltage drop and the rate of decline are proportional to the current density. The higher the current, the greater the initial voltage drop and rate of decline.

After the initial effects have disappeared, increasing or decreasing the discharge current will cause the battery voltage to react accordingly, based on the ohmic resistance of the battery at the time of the load change. The voltage will then continue to decline at a rate determined by the new discharge current, state of charge (the amount of energy previously removed), cell temperature, and age. For load reductions, the battery voltage will rise immediately due to ohmic effects, then more slowly for up to several minutes due to chemical action in the battery.

Battery manufacturers typically provide either tabular or graphical data to describe cell discharge characteristics for a given discharge rate. This data is based on new cells having nominal specific gravity electrolyte at 77 °F (25 °C).

16.5.1.2 Short-circuit characteristics

The peak short-circuit current that a battery can deliver is limited by its internal resistance (including intercell connectors). The greater the battery's resistance, the lower the peak short-circuit current is. In addition, it takes a finite time for the battery to reach its peak short-circuit current value. The rise time is dependent on the ratio of the battery's inductance to its reactance (i.e., time constant). The battery's time constant increases in direct proportion to its inductance (with resistance held constant).

Figure 16-2 shows the equivalent circuit used for calculating battery short-circuit current.

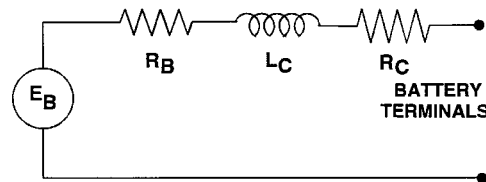

where

R_B is the battery internal resistance,

L_C is the battery circuit inductance,

R_C is the battery connector resistance (sum of all internal cable and connector resistances).

Source: [B6]. Reprinted with the permission of General Electric Company.

Figure 16-2—Battery equivalent circuit

The internal resistance of a cell is calculated from the slope of the initial volts line on the characteristic curve for the cell. Figure 16-3 shows a discharge characteristic curve for a typical 2500 Ah, 35 plate (total) cell.

In accordance with IEEE Std 946-1992 [B9]:

$$R_{\text{cell}} = \frac{R_p}{N_p} \quad (16-1)$$

where

R_{cell} is the total internal cell resistance, in ohms (Ω),

R_p is the resistance per positive plate, in ohms (Ω),

N_p is the number of positive plates.

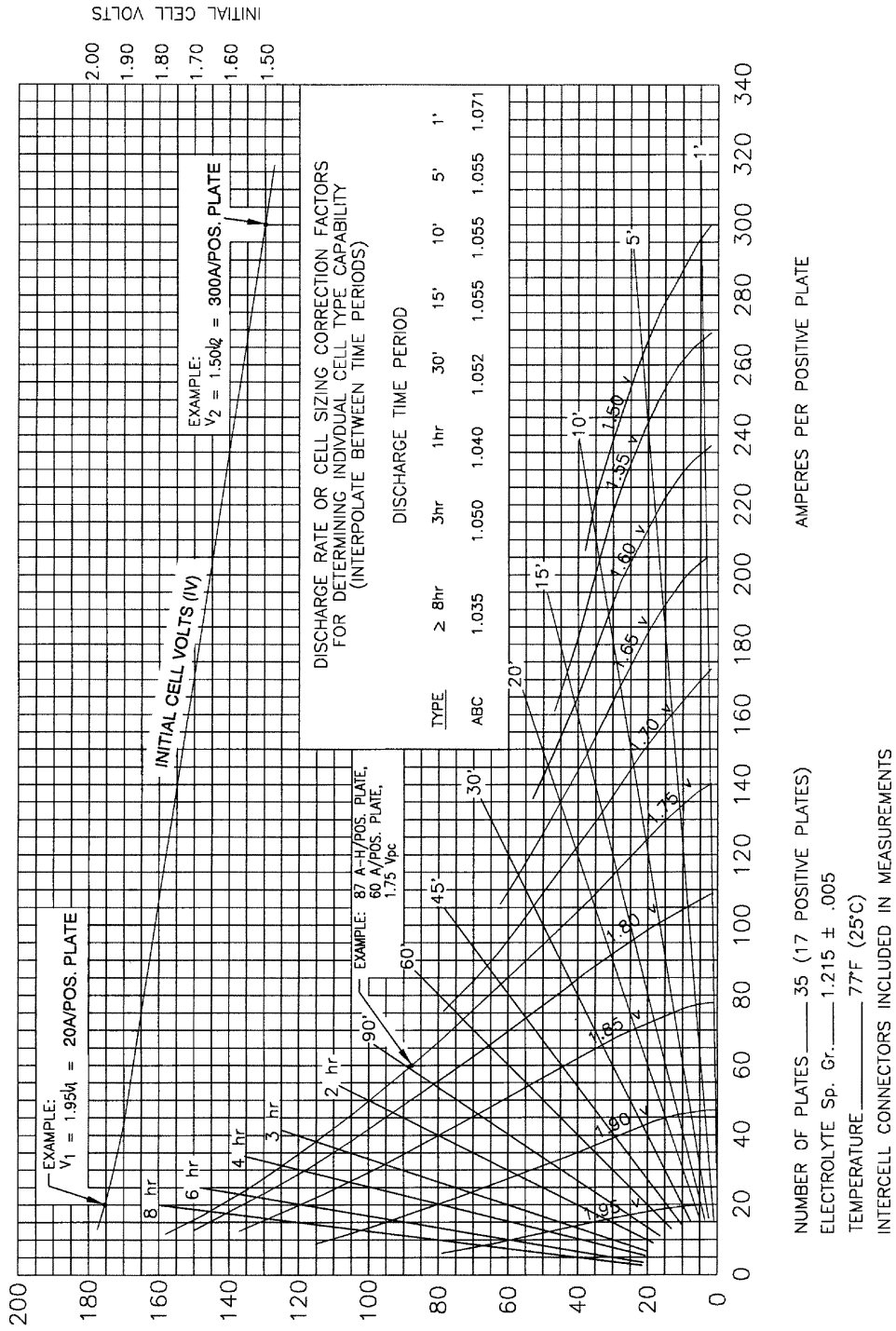

Figure 16-3—Discharge curve for a typical lead acid cell

and

$$R_p = \frac{V_1 - V_2}{I_2 - I_1} \Omega/\text{positive plate} \quad (16-2)$$

where

I_1 and I_2 are the amperes (A)/positive plate

for any two voltage and current points along the line.

Example 1:

From Figure 16-3 (initial volts curve):

$$V_1 = 1.95 \text{ V} \quad I_1 = 20 \text{ A/positive plate}$$

$$V_2 = 1.50 \text{ V} \quad I_2 = 300 \text{ A/positive plate}$$

Per equation (16-2):

$$\begin{aligned} R_p &= \frac{1.95 - 1.50}{300 - 20} \\ &= 0.00161 \Omega/\text{positive plate} \end{aligned}$$

Given:

35 total plates (17 positive plates/cell)
60 cells @ 2.00 V_{pc}

Then

$$R_{\text{cell}} = \frac{R_p}{N_p} = \frac{161 \times 10^{-3}}{17} = 94.7 \times 10^{-6} \Omega$$

$$R_B = R_{\text{cell}} \times \text{number of cells} \quad (16-3)$$

$$= 94.7 \times 10^{-6} \times 60 = 5.68 \times 10^{-3} \Omega$$

The next step is to calculate the battery cable resistance (R_c). Intercell connector resistance is often included in the manufacturer's discharge curves and initial cell voltage lines. If it is not included, the connector resistance must be added to the cable resistance. Intercell connector

resistance should be available from the manufacturer. Battery cable resistance can be calculated as follows:

R_{cable} = battery cable resistance per unit length (e.g., $\Omega/1000$ ft)

$$R_c = \frac{\text{total length of battery connector (in ft)} \times R_{\text{cable}}}{1000 \text{ ft}} \quad (16-4)$$

Example 2:

As shown in Figure 16-4, there are four segments of battery cable to be included in this portion of the calculation. The 100 ft (30.5 m) cable to the 125 Vdc bus (as shown in Figure 16-1) is addressed separately. The battery cable length is

- 1) Total length of battery connector ($\text{length}_{\text{cc}}$):

$$\text{length}_{\text{cc}} = 15 \text{ ft} + 6 \text{ ft} + 3.25 \text{ ft} + 1 \text{ ft} = 25.25 \text{ ft (7.7 m)} \quad (16-5)$$

- 2) Connector cable is 3-350 kcmil copper, which has a resistance of $10.2 \times 10^{-3} \Omega/1000$ ft ($33.65 \times 10^{-3} \Omega/\text{km}$) at 25°C (see Example 4 in 16.5.4.1).

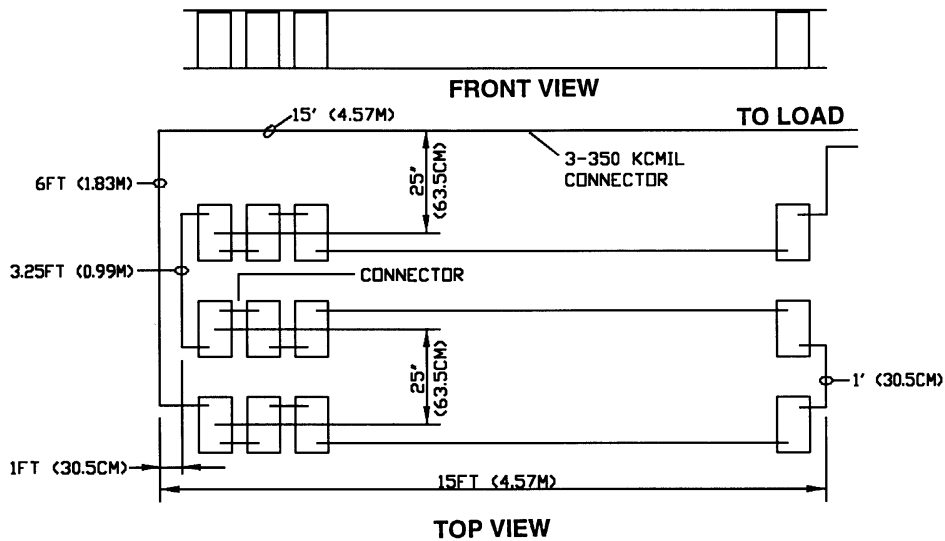

Source: [B6]. Reprinted with the permission of General Electric Company.

**Figure 16-4—Typical 60-cell battery installation—
arranged in three rows**

Therefore,

$$R_c = \left(\frac{25.25 \text{ ft}}{1000} \right) \times 10.2 \times 10^{-3} \Omega/1000 \text{ ft} = 257.6 \times 10^{-6} \Omega$$

The inductance of the battery circuit (L_c) is equal to the inductance of the battery connector (L_{bc}) plus the inductance of the battery string (L_{bs}).

$$L_c = L_{bc} + L_{bs} \quad (16-6)$$

The inductance of the cell connectors (L_{bc}) can also be determined by analysis from data similar to that shown in Figure 16-4 using the following formula (General Electric [B6]):

$$L_{bc} = 30.5 \times 10^{-9} \left(2 \ln \frac{d}{r} + 0.5 \right) \text{ H/ft} \quad (16-7)$$

where

- d is the distance between conductor centers = 25 in and 12 in (63.5 cm and 30.5 cm),
- r is the radius of the conductor = 0.590 in (15.0 mm).

$$\begin{aligned} \text{NOTE—effective radius} &= \sqrt{\left(\frac{\text{number of conductors} \times \text{area of one conductor}}{\pi} \right)} \\ &= \sqrt{\left(\frac{3 \times 0.364 \text{ in}^2}{\pi} \right)} \\ &= 0.590 \text{ in (15.0 mm)} \end{aligned}$$

The 3-350 kcmil battery connector cable is in parallel with a 15 ft (4.57 m) section of the battery string. To simplify the calculation, the 15 ft (4.57 m) section of the battery string is considered to be equivalent to the 3-350 kcmil connector cable.

Then

$$\begin{aligned} L_{bc} &= 30.5 \times 10^{-9} \left(2 \ln \frac{25}{0.590} + 0.5 \right) \text{ H/ft} \\ &= 0.244 \mu\text{H/ft} \end{aligned}$$

$$\begin{aligned} L_{bc} &= 30.5 \times 10^{-9} \left(2 \ln \frac{12}{0.590} + 0.5 \right) \text{ H/ft} \\ &= 0.199 \mu\text{H/ft} \end{aligned}$$

and

$$L_{bc} = 30.5 \times 10^{-9} \left(2 \ln \frac{180}{0.590} + 0.5 \right) \text{H/ft}$$

$$= 0.364 \mu\text{H/ft}$$

Therefore,

$$L_{bc} = (0.244 \mu\text{H/ft} \times 15 \text{ ft}) + (0.199 \mu\text{H/ft} \times 3.25 \text{ ft}) + (0.364 \mu\text{H/ft} \times 1 \text{ ft}) = 4.67 \mu\text{H}$$

Battery cell inductance values obtained from testing on lead acid cells ranging from 10–1600 Ah are presented in Willihnganz and Rohner [B11]. These results indicate that battery cell inductances are on the order of 0.1 $\mu\text{H}/\text{cell}$. Specifically, the inductance ranges are shown in Figure 16-5 Willihnganz and Rohner [B11]. Note that the battery inductance levels off at $\approx 0.145 \mu\text{H}/\text{cell}$ for batteries larger than 1300 Ah; therefore, 0.145 $\mu\text{H}/\text{cell}$ can be used for large installations (i.e., above 1300 Ah).

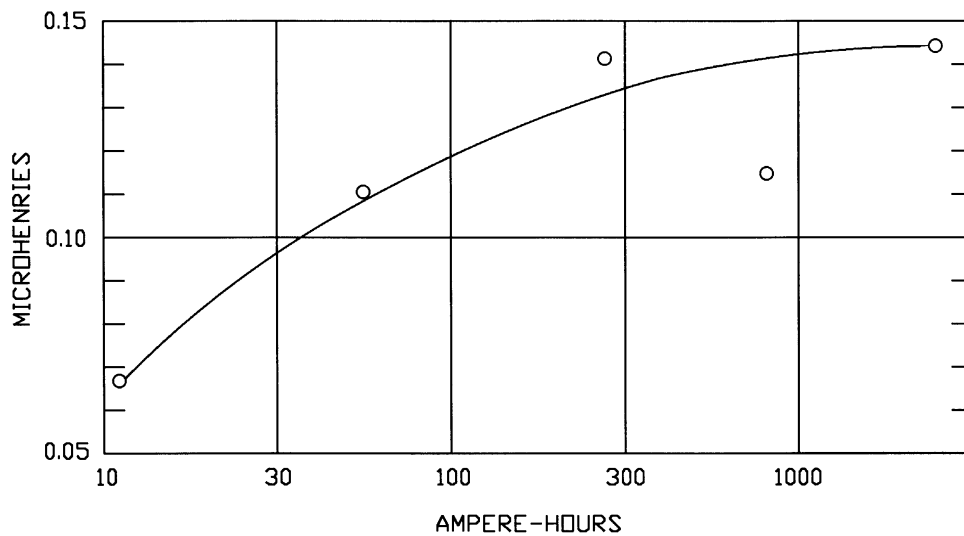

Figure 16-5—Inductance vs. battery size for lead-acid cells [B11]

If 0.145 $\mu\text{H}/\text{cell}$ is used for a 2500 Ah, 60 cell battery, then

$$L_{bs} = 0.145 \mu\text{H/cell} \times 60 \text{ cells} = 8.7 \mu\text{H}, \quad (16-8)$$

Then, using Equation (16-6), the inductance of the battery circuit (L_c) is as follows:

$$\begin{aligned} L_c &= L_{bc} + L_{bs} \\ &= 4.67 \mu\text{H} + 8.7 \mu\text{H} \\ &= 13.4 \mu\text{H} \end{aligned}$$

which gives a battery equivalent circuit as shown in Figure 16-6.

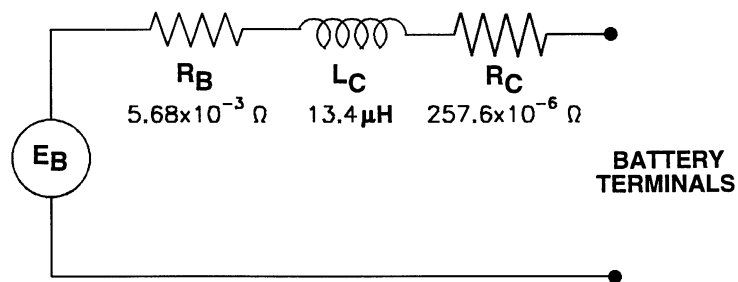

Source: [B6]. Reprinted with the permission of General Electric Company.

Figure 16-6—Battery equivalent circuit with component values

As an alternative, the inductance of the battery string can be calculated if the time constant and resistance are known (e.g., from actual field test data). For example, if short-circuit tests show a time constant of 1.07 ms, and the battery resistance (including intercell connectors) is 0.0127 Ω , the inductance can be calculated as follows:

$$L_{bs} = tR_b \tag{16-9}$$

Therefore,

$$L_{bs} = 1.07 \times 10^{-3} \text{ s} \times 12.7 \times 10^{-3} \Omega = 13.6 \mu\text{H}$$

16.5.2 Battery charger

16.5.2.1 Voltage regulation

One of the main goals of load flow/voltage drop studies is to determine whether sources are applied above their output current ratings. Battery chargers are generally considered to be “stiff” sources in that their output voltage is well-regulated from no load to full load. Battery chargers are normally modeled as a constant voltage source in series with a small resistance for load flow/voltage drop studies, assuming that they are applied within their ratings.

Chargers typically have an integral current-limiting circuit designed to limit steady-state output current. This circuit reduces their output voltage to limit output current to a safe value for their internal components. The current limiting circuit normally has an adjustable setpoint that will not exceed $\approx 150\%$ of the nominal output current rating. When the set point is reached, the charger begins to behave more like a constant current source than a constant voltage source.

16.5.2.2 Short-circuit characteristics

Most standard battery chargers are supplied with a current-limiting feature that limits the steady-state fault current the charger can deliver. Generally, it is conservatively assumed that the charger will deliver no more than 150% of its rated output for an extended period of time. IEEE Std 946-1992 [B9] states that for a typical dc system, the short-circuit current from the charger has already peaked and decayed before the short-circuit from the battery reaches its peak.

The magnitude and duration of the transient short-circuit current are dependent on the charger design (including rectifier type and control circuit response time) and the X/R ratio of the ac supply, as well as the inductance and resistance of the fault circuit. The transient typically peaks very quickly, at 5–20 times the charger current rating, and then decays. In some charger designs the transient is as short as $\frac{1}{2}$ cycle (8 ms), and in others it has been shown to last as long as 100 ms. Therefore, in conjunction with the battery time constant, the maximum coincident short-circuit current is conservatively calculated as the sum of the peak short-circuit from the battery and the peak value from the charger. Steady-state short-circuit current is conservatively calculated as the sum of the peak short-circuit current from the battery and the current limit value from the charger.

16.5.3 Motors

16.5.3.1 Voltage/power characteristics

DC motors are available in a wide variety of designs for many different applications. All of the various designs behave somewhat differently as terminal voltage changes. This behavior is dependent upon both the motor design and the load characteristic as speed varies. Some motors exhibit a constant current characteristic for a fairly wide range of terminal voltage conditions. Others exhibit a constant power characteristic. If the behavior of a motor for varying terminal voltage is unknown, it is usually conservative to assume that it has a constant power characteristic when performing load flow/voltage drop studies.

When dc motors are started, there can be a significant inrush current depending upon motor design and starting technique. As with ac motors, the duration of this inrush current is dependent on both motor design and load speed/torque characteristics. Motor starting can be evaluated by using static techniques, such as the voltage drop snapshot described in 9.4.1 of Chapter 9, or by using dynamic techniques. Dynamic studies can be performed to evaluate system conditions on motor starting when more rigorous analysis is required. Dynamic analyses are not normally required for dc auxiliary power systems. They are more often

performed for larger dc systems such as those found in mining operations, where large motors constitute a higher proportion of the dc system load.

16.5.3.2 Short-circuit characteristics

The short-circuit model and approximate curve of short-circuit vs. time of a dc motor can be represented as shown in Figure 16-7.

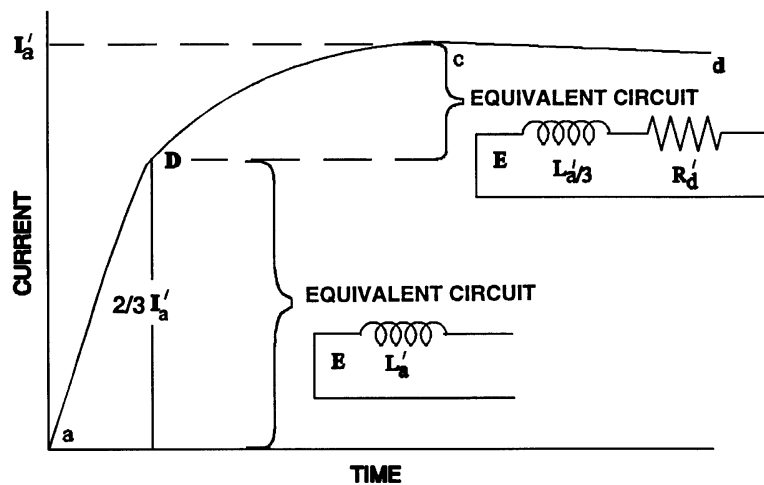

Source: [B5]. Reprinted with the permission of General Electric Company.

Figure 16-7—Typical short-circuit characteristic of dc motor

The approximate short-circuit characteristic of a dc motor, Figure 16-7, can be drawn by determining two factors:

- a) Initial rate of rise of current
- b) Peak short-circuit current

The section of the curve between points a and b in Figure 16-7 (initial rate of rise of the short-circuit current) is determined by the motor circuit time constant. Point b is the point at which the current magnitude is equal to two thirds of its maximum value. Point c is the peak short-circuit current. Section b-c-d of the curve is drawn to represent an exponential type of curve with section b-c being an exponential approaching I'_a and section c-d being an exponential approaching the reduced steady-state fault current level (General Electric [B5]).

The initial rate of rise of the fault current is as follows [B5]:

$$di_a/dt = \frac{V_1}{L_a'} \quad (16-10)$$

where

V_1 is the rated machine voltage, in V,

L_a' is the machine armature circuit unsaturated inductance, in H.

$$L_a' = \frac{19.1 C_x V_1}{PN_1 I_a} \text{ H} \quad (16-11)$$

where

P is the number of poles,

N_1 is the base speed, in r/min,

I_a is the rated machine current, in A,

C_x is 0.4 for dc motors without pole face windings,
is 0.1 for dc motors with pole face windings.

The peak short-circuit current is as follows:

$$I_a' = \frac{I_a}{R_d'} \quad (16-12)$$

where

R_d' is the transient effective armature resistance of machine (per unit on the machine base)

Example 3:

Given the following motor parameters:

4-pole motor
Constant speed (1900 r/min) (N_1)
Shunt
3 hp
115 V (V_1)
Noncompensated (no pole face winding)
22 A rated current (I_a)
 $R_d' = 0.175$ p.u.

The peak short-circuit current is as follows:

$$I_a' = \frac{I_a}{R_d'} = \frac{22}{0.175} = 126 \text{ A}$$

The initial rate of rise is as follows:

$$\frac{di_a}{dt} = \frac{V_1}{L_a} \quad (16-13)$$

where

$$\begin{aligned} L_a' &= \frac{19.1 C_x V_1}{PN_1 I_a} \\ &= \frac{19.1 \times 0.4 \times 115}{4 \times 1900 \times 22} = 5.3 \text{ mH} \end{aligned}$$

Therefore,

$$\frac{di_a}{dt} = \frac{115}{0.0053} = 21\,700 \text{ A/s}$$

The time constant of the motor is as follows:

$$T_m = \frac{L_a'}{R_d'}$$

Converting to ohms,

$$\begin{aligned} R_d' &= 0.175 \text{ p.u.} \left(\frac{115 \text{ V}}{22 \text{ A}} \right) \\ &= 914.8 \times 10^{-3} \Omega \end{aligned}$$

Therefore,

$$\begin{aligned} T_m &= \frac{L_a'}{R_d'} \\ &= \frac{5.3 \times 10^{-3} \text{ H}}{914.8 \times 10^{-3} \Omega} \\ &= 5.8 \text{ ms} \end{aligned}$$

16.5.4 Branches

Load flow/voltage drop studies are normally done for steady-state conditions; therefore, branches are modeled as purely resistive elements. DC resistance values for most common bus and cable sizes can be found easily in many codes and handbooks. Care must be taken to ensure that resistance values used are dc resistance values. Many standard sources and manufacturers' data give ac resistance, which includes skin and proximity effects. The resistance tables in most codes and handbooks also include formulas or multipliers for correcting the table values to match the temperatures to be used for the study in question. The resistivity of metal conductors rises with temperature. The effect of this additional resistance can be quite significant for circuits with long runs and/or small conductor sizes. Therefore, it is common practice to assume that a cable is at its rated conductor temperature (typically, 75 °C or 90 °C) when performing load flow/voltage drop studies. An example of a widely accepted method of correcting cable resistances for temperature is included in the following discussion of branch models for short-circuit studies. Cable resistances must include the total resistance of the circuit. If two conductor cables are used for a circuit, the total circuit length is twice the cable length. Circuit length can be difficult to determine for control circuits in which one leg is longer than the other.

For load flow/voltage drop studies, the resistance for each branch must include the resistance of overload heaters in motor starters where applicable.

Reversing motors are a special case. Usually four wires are required between the motor and the starter. This effectively quadruples the conductor length if the starter is in a motor control center (MCC) rather than local to the motor. Some compound wound motors used in reversing applications utilize a fifth wire for the shunt field. In most studies, this wire is conservatively ignored. The current in the fifth wire is added to the armature current. This results in a larger calculated voltage drop and consequently a lower calculated motor terminal voltage than would actually be found in the field.

16.5.4.1 Cable/bus

Typical branches modeled in dc power systems analysis connecting equipment are cables and buses. These resistances are usually taken at 25 °C for conservatism in short-circuit studies, since cable resistance decreases as cable temperature decreases.

To correct cable resistance from any initial temperature to any final temperature, the following formula is used (the National Electrical Code[®] [NEC[®]] [NFPA 70-1996] [B10]):

$$R_2 = R_1 [1 + \alpha (T_2 - T_1)] \quad (16-14)$$

where

- R_2 is the resistance at desired temperature (T_2), Ω ,
- R_1 is the resistance at initial temperature (T_1), Ω ,
- α is 3.23×10^{-3} for copper conductors, 3.30×10^{-3} for aluminum conductors, $\Omega/^\circ\text{C}$,
- T_1 is the initial temperature, $^\circ\text{C}$,
- T_2 is the desired temperature, $^\circ\text{C}$.

Example 4:

Given:

3-350 kcmil copper conductors in parallel at 75 °C, $R = 0.0367 \Omega/1000 \text{ ft}$ ($120.4 \times 10^{-3} \Omega/\text{km}$) per conductor (NFPA 70-1996 [B10]).

$$R = \frac{36.7 \times 10^{-3} \Omega/1000 \text{ ft}}{3} = 12.2 \times 10^{-3} \Omega/1000 \text{ ft} (40.14 \times 10^{-3} \Omega/\text{km})$$

Correcting to 25 °C:

$$\begin{aligned} R_2 &= 12.2 \times 10^{-3} (1 + 3.23 \times 10^{-3} (25 - 75)) \\ &= 10.2 \times 10^{-3} \Omega/1000 \text{ ft} (33.65 \times 10^{-3} \Omega/\text{km}) \end{aligned}$$

16.5.4.2 Motor control circuits

The resistance of thermal overload heaters in motor-starters is often a significant portion of a branch circuit's resistance. For small motors it is often greater than the resistance of the circuit conductors. The resistance of fuses, circuit breakers, starter contacts, and switches is usually negligible and is not included in most branch models.

For conservatism, the effects of combination motor-starter unit and thermal overload heater resistance on short-circuit current are normally ignored; but can be accounted for if removing conservatism is desirable.

16.6 Load flow/voltage drop studies

When the resistance diagram has been completed, a load flow/voltage drop analysis can be performed. As with ac systems, an iterative approach is required unless the system loads are all constant resistance (a substation with only switchgear and lamps for example) or all constant current. If all loads on the system are of one of these two types, a direct solution can be obtained using voltage divider circuits. The iterative approach gives the same results as the direct approach, and software that will quickly and accurately perform the necessary iterations is available. Since the iterative approach usually converges regardless of the load mix and system configuration, it is normally used for all but single branch circuit calculations.

Load flow calculations on a dc system utilize the same basic network solution techniques as an ac system. The base equation is essentially the same as Equation (6-2):

$$[I] = [Y] [V]$$

For steady-state dc systems inductance is ignored and the equation becomes the following:

$$[I] = [G] [V]$$

where

- [*I*] is the vector of total currents flowing into the network nodes,
- [*G*] is the network conductance matrix,
- [*V*] is the vector of voltage at the network nodes.

The conductance [*G*] matrix is built in the same manner as the [*Y*] matrix for ac systems. A number of solution algorithms (Gauss-Seidel, Newton-Raphson, and others) are available to solve the resulting networks. These techniques are described in Chapters 5 and 6, as well as in many other texts and papers. Therefore, they will not be discussed here.

If the system is being supplied by a charger or other stiff source, the load flow needs to be run only once to determine bus voltages and currents.

If the system is supplied by a battery, neither the power nor the voltage at the swing bus can be held constant as it can with other sources. It is prudent to calculate load flow and voltage drop for a minimum of three conditions on each battery system. These conditions are the battery equalizing voltage (if the battery is equalized on line), the battery float voltage, and the battery end of discharge voltage. These three cases usually cover the highest, normal, and lowest voltages seen on the dc system. If the battery experiences large load additions during its discharge cycle, the load flow/voltage drop and battery terminal voltage should also be determined for these points in the profile to verify that the voltage available at the loads does not drop below their minimum requirement. While most relays can withstand a considerable voltage dip before they drop out, electronic equipment is often more sensitive to voltage dips. It should also be noted that, depending on system configuration, the lowest voltage seen at a panel or load may not occur when the battery voltage is lowest.

Table 16-1 shows the program output for several iterations of a load flow/voltage drop calculation, which illustrates the iterative technique previously described for dc systems being supplied by a battery (refer to Figure 16-1 for the corresponding system). Terminal voltages from a load flow/voltage drop analysis of all nodes in Figure 16-1 are shown with the short-circuit results in Table 16-2.

Table 16-1
Load flow/voltage drop iteration results at the battery

V_{batt}	I_{batt}	$I/\text{positive plate}$	V_{pc}
125.0	885.7	52.1	2.08
115.3	955.4	56.2	1.92
114.2	963.9	56.7	1.90
113.4	969.0	57.0	1.89

16.6.1 Load profile

As noted above, a load flow/voltage drop analysis is essentially an analysis of a single “snapshot” in time. To accurately determine system voltages during a discharge event, it is essential to know how much energy has been removed from the battery (the initial state of charge) as well as the current being drawn from it for the instant in time being considered. This is typically done by developing a load profile showing time vs. current on an x - y plot for the duration of the anticipated discharge event. Developing this profile can be fairly simple for a battery feeding a relatively constant load or extremely complex for a system involving a large number of relays, controls, and instruments. Additional discussion regarding the development of battery duty cycles can be found in IEEE Std 485-1997 [B8] and IEEE Std 946-1992 [B9].

16.6.2 Battery terminal voltage

Batteries are not well-regulated sources because their output voltage at any given time is dependent upon both the load current being supplied and the total energy removed from the battery prior to the time in question. Since load flow/voltage drop studies are steady-state problems, battery voltage is generally assumed or calculated for the specific time in question.

Battery manufacturers typically provide discharge characteristic curves (Figure 16-3) or tables for use in determining battery capacity and terminal voltage.

The energy removed from a battery is measured in ampere-hours (Ah) removed, and can be calculated fairly easily for any load profile. Ampere-hours removed is calculated by adding the product of current drawn and the duration for each period in the load profile.

Given the ampere-hours removed, the number of positive plates in a cell, and the current flowing through the cell, the cell voltage can be determined from the manufacturer’s data (usually graphs or tables) by interpolating as necessary. Multiplying the cell voltage by the number of cells in the string gives battery terminal voltage.

Battery terminal voltage for a given load current and energy removed can be determined from the battery curves. Energy removed is calculated by determining the ampere-hours removed from the battery and dividing it by the number of positive plates per cell. The amperes per positive plate is simply the current flowing in the battery string divided by the number of positive plates in each cell. These numbers are plotted on the battery curves and the cell voltage is read by interpolating as necessary between cell voltage curves. The cell voltage is multiplied by the number of cells in the string to obtain battery voltage. For example, using the battery curve for a 35-plate cell in Figure 16-3, if the battery has had 1480 Ah removed, and the battery load is 1020 A, the cell voltage would be found by plotting the following:

$$\frac{1480 \text{ Ah}}{17 \text{ positive plates}} = 87 \frac{\text{Ah}}{\text{positive plate}} \quad (16-15)$$

vs.

$$\frac{1020 \text{ A}}{17 \text{ positive plates}} = 60 \frac{\text{A}}{\text{positive plate}}$$

This yields a cell voltage of $1.75 V_{pc}$, or 105 Vdc for the terminal voltage on a 60-cell battery.

Some cell manufacturer's curves have derating factors for discharge rate or time, temperature, and different cells on each curve. These must be carefully accounted for in determining cell voltages. A great deal of care must be taken in reading the cell voltages. Any error in reading the cell voltage from the graphs or tables will be multiplied by the number of cells and significantly affect the calculated battery terminal voltage.

16.7 Short-circuit studies

Resistance and inductance diagrams are generally created to aid in calculation of short-circuit values. The resistance diagram is used to calculate the maximum current for a short-circuit at any point in the system. The inductance diagram is used to calculate the initial rate of rise and time constant of the total short-circuit current. The resistances and inductances are combined in parallel or series until one equivalent system resistance and inductance, respectively, is determined to represent the system from the point of short-circuit back to the voltage source.

The maximum short-circuit current is calculated based on the equivalent resistance (R_{eq}) from the resistance diagram as follows (General Electric [B4]):

$$I_T = \frac{E}{R_{eq}} \quad (16-16)$$

where

- E is the system voltage, in V,
- R_{eq} is the equivalent system resistance, in Ω ,
- I_T is the maximum short-circuit current, in A.

The initial rate of rise is calculated based on the equivalent inductance (L_{eq}) from the inductance diagram as follows:

$$\frac{di_t}{dt} = \text{rate of rise of total current} = \frac{E}{L_{eq}} \text{ (A/s)} \quad (16-17)$$

The time constant is calculated based on the equivalent inductance (L_{eq}) divided by the equivalent resistance (R_{eq}) from the inductance and resistance diagrams as follows:

$$T = \frac{L_{eq}}{R_{eq}} \text{ (s)} \quad (16-18)$$

Example 5:

From Figure 16-6, the time constant of the 2500 Ah battery is as follows:

$$T = \frac{L_{eq}}{R_{eq}} = \frac{13 \mu\text{H}}{(5.68 \times 10^{-3} \Omega + 214.2 \times 10^{-6} \Omega)} = 2.2 \text{ ms}$$

This is consistent with the 2 ms time constant determined by recent testing on a two cell 1870 Ah battery (ATI Test No. 0792-1 [B1]).

The separate resistance and inductance diagrams for Figure 16-1 are not drawn here. The cable resistance values were taken from Chapter 9, Table 8 of NFPA 70-1996 [B10] and adjusted to 25 °C before short-circuit calculations were made. For simplicity in this example, cable inductances were calculated from ac reactance values in steel conduit taken from Chapter 9, Table 9 of NFPA 70-1996 [B10], which may not be representative of the dc inductances for a particular dc system. In addition, the short-circuit calculation was run with both the battery and battery charger connected to the main bus. Table 16-2 shows the short-circuit and time-constant results for each node in Figure 16-1.

Table 16-2
Short circuit and load flow/voltage drop results

Node	Fault current (A)	Terminal voltage (V)	Time constant (ms)
Battery	21 843	113.4	1.63
Charger 1	13 158	110.9	1.23
Charger 2	—	110.9	—
Load center	16 444	110.9	1.45
Annunciators	499	107.8	0.152
DC Ckts	6 636	103.8	1.87
Emergency lighting	6 115	108.1	1.89
Inverter	5 225	107.1	1.44
MCC-1	4 623	108.2	0.311
MOV-1	1 095	101.9	0.0765
MOV-2	847	108.2	0.0720
MOV-3	378	108.2	0.0534
PUMP-1	3 821	107.8	0.0914

16.8 International guidance on dc short-circuit calculations

Papers have been presented (Berizzi et al. 1995 [B2] and Berizzi et al. 1994 [B3]) discussing the short-circuit calculation methods for dc systems contained in IEC Project #73.6.1 [B7]. It is not within the scope of this chapter to present the methods contained in the IEC draft standard. However, these papers and IEC Project #73.6.1 are mentioned here to provide additional information sources on the subject of dc short-circuit calculations. It should be noted that one of the papers [B2] shows substantial agreement between some of the models used in IEC Project #73.6.1 and detailed simulations performed using a PC-based version of a well-accepted transient analysis program.

16.9 Bibliography

Additional information may be found in the following sources:

[B1] ATI Test No. 0792-1 “Test Report Stationary Battery Short-Circuit Test,” Albér Technologies, Inc., Boca Raton, FL, July 9 & 10, 1992.

[B2] Alberto Berizzi, et al. “IEC draft standard evaluation and dynamic simulation of short-circuit currents in dc systems,” Presented at the IEEE Industrial Applications Society Fall Conference, Oct. 1995.

[B3] Alberto Berizzi, et al. “Short-circuit current calculations for dc systems,” presented at the IEEE Industrial Applications Society Fall Conference, Oct. 1994.

[B4] General Electric, D-C System Short-Circuit Current Calculations,” *GE Industrial Power Systems Data Book*, .178.

[B5] General Electric, “Short-Circuit Characteristics of D-C Motors and Generators,” *GE Industrial Power Systems Data Book*, .171.

[B6] General Electric, “Short-Circuit Characteristics of Lead-Acid Storage Batteries,” *GE Industrial Power Systems Data Book*, Project .173.

[B7] IEC Project #73.6.1 Draft Standard, “Calculation of short-circuit currents in dc auxiliary installations in power plants and substations,” Version V4, TC73, May 1994.

[B8] IEEE Std 485-1997, IEEE Recommended Practice for Sizing Lead Acid Batteries for Stationary Applications.²

²IEEE publications are available from the Institute of Electrical and Electronics Engineers, 445 Hoes Lane, P.O. Box 1331, Piscataway, NJ 08855-1331, USA.

[B9] IEEE Std 946-1992, IEEE Recommended Practice for the Design of DC Auxiliary Power Systems for Generating Stations.

[B10] NFPA 70-1996, National Electrical Code[®](NEC[®]). Table 430-147, and Chapter 9, Tables 8 and 9.³

[B11] Willihnganz, E., and Rohner, P., "Battery impedance: farads, milliohms, microhenrys," presented at the AIEE Summer and Pacific General Meeting and Air Transportation Conference, Seattle WA, June, 1959.

³The NEC is available from Publications Sales, National Fire Protection Association, 1 Batterymarch Park, P.O. Box 9101, Quincy, MA 02269-9101, USA. It is also available from the Institute of Electrical and Electronics Engineers, 445 Hoes Lane, P.O. Box 1331, Piscataway, NJ 08855-1331, USA.

INDEX

A

Acceleration factors, 116
Acceleration time analysis (motors), 236–239, 248, 253–262
AC decrement, 168, 174–176, 178–179
Active network elements, 46–49
Active power, 47
Admittance, 45
Air-core reactors, 307
Algebra. *See* Matrix algebra; Simultaneous algebraic equations, solution of
Aluminum conductors, 60–61, 391. *See also* Conductors
Ambient and conductor temperature (F_c), 391–393
American National Standards Institute (ANSI) standards (short-circuit analysis), 172–179, 203
American Standard Code for Information Interchange (ASCII), definition of, 122
Ampacity, cable. *See* Cable ampacity studies
Analog computers (ac network analyzer), 1, 103, 140
Analytical procedures
 errors, common causes of, 13
 Fourier representation, 21–22
 Laplace expansion, 112
 Laplace transform, 22–29, 120, 315–323, 336–337
 linearity, 14–15
 Norton equivalent circuit, 19
 overview, 13–14
 per-unit method, 38–40, 71–73
 phasor representation, 20–21
 single-phase equivalent circuit, 29–31
 sinusoidal forcing function, 19–20
 superposition, 15–16
 symmetrical component analysis, 32–37, 170
 Thevenin equivalent circuit, 16–19, 175–176

ANSI (American National Standards Institute) standards (short-circuit analysis), 166, 172–179, 203
Arc furnace installations
 switching transient analysis, 355
Armature capacitance to ground, 368
Arresters, surge, 339, 341
ASCII (American Standard Code for Information Interchange), definition of, 122
Autotransformers, 247–248, 259
 data requirement for stability studies, 221
 starters, 235
Availability, definition of, 375

B

Batch computer programs, 127
Battery characteristics, 448–455
 battery terminal voltage, 463–464
 short-circuit characteristics, 449–455
 voltage during discharge, 448–449
Battery charger characteristics, 455–456
 short-circuit characteristics, 456
 voltage regulation, 455–456
Binary, definition of, 122
Bit, definition of, 122
Branch
 data (load flow studies), 139–140
 definition of, 54
Branch element modeling, 55–71
 cables, 59–60. *See also* Cable capacitors, 64. *See also* Capacitors constants. *See* Conductors, constants lines, 55–59. *See also* Lines reactors, 64. *See also* Reactors transformers. *See* Transformers, models
Breaking short-circuit current, 177
Bug, definition of, 122
Bus
 dc power systems studies, 460–461
 definition of, 54, 107, 122
 load flow studies, 138–139, 143
 models. *See* Bus element models swing, 138, 143
Bus admittance matrix, 182–183
Bus element models, 80–98

electric furnaces, 98
induction motors. *See* Induction motors, models
lighting and electric heating, 97–98
loads in general, 80–81
shunt capacitors, 98
shunt reactors, 98
synchronous machines. *See* Synchronous machine models
Bushings capacitance to ground, 365
Bus impedance matrix, 183
Byte, definition of, 122

C

Cable

ampacity. *See* Cable ampacity studies
charging current, 373
dc power systems studies, 460–461
energizing and reclosing transients, 356
grouped, 395–400
harmonic analysis models, 279, 281–282
lightning and switching surge response, 355
models, 55–60, 281–282
overhead lines, compared to, 60
short-circuit studies, 173
Cable ampacity studies, 383–404
ampacity adjustment factors, 388–398
ambient and conductor temperature (F_c), 391–393
grouping (F_g), 395–398
thermal resistivity (F_{th}), 393–395
computer program application, 386–388
example, 399–403
heat flow analysis, 383–386
overview, 10–11, 383–384, 403–404
CADD (computer-aided design and drafting) software, 437
Capacitance, 313–314
generator armature, 368
phase bus, 369
transformer winding to ground, 371
Capacitive susceptance, 45
Capacitor banks. *See also* Capacitors
data requirement for stability studies, 221

inductance between, 369
switching examples
electromagnetic transients program (EMTP), 347–361
transient network analyzer (TNA), 341–345

Capacitors

banks. *See* Capacitor banks
de-energization, restrike phenomena during, 356
harmonic filters, 306–307
modeling, 64
power factor correction, 270, 275–276, 302
shunt, 98, 279
starting systems, 235–236
surge, 339
switching transient analysis, 325–237, 356

Central processing unit (CPU), definition of, 122

Circuit breakers, 378, 431, 435

rating structure, 176–177
transient network analyzer (TNA), 340

“Close and latch” currents, 172

Co-generation (co-gen) companies, 209

co-gen plant that imports power from local utility, 226–227

co-gen plant with excess generation, 225–226

oscillations between industrial plant and utility, 224, 227–228

Column matrix, 104

Column vector, 104

Commercial power systems. *See* Power systems analysis

Complex power, 47

Component, definition of, 375

Computer-aided design and drafting (CADD) software, 437

Computer solutions and systems

cable ampacity studies, 386–388

computer systems, 122–129

hardware, 124–126

software, 126–129, 162

terminology, 122–124

consulting services, 443

- ground mat studies, 420–428
 - harmonic analysis, 277, 282, 284–286
 - history of
 - digital computers, 1–2, 103, 140
 - early analog computers, 1, 103, 140
 - load flow studies, 133, 140–141, 162
 - motor-starting studies, 250–253, 255–257, 260–262
 - numerical solution techniques, 104–121
 - differential equations, 120–121
 - matrix algebra fundamentals, 104–107
 - power system network matrices, 107–110
 - simultaneous algebraic equations. *See* Simultaneous algebraic equations, solution of
 - overview, 7–10, 12–13, 103–104
 - protective coordination studies, 435–443
 - common structure, 436–441
 - coordination programs, 435, 441–443
 - TCC plotting programs, 435, 441
 - short-circuit studies, 182–186
 - software, 184–186
 - system matrices, 182–183
 - stability studies, 218–223
 - data requirements, 221–222
 - disturbances, simulation of, 220–221
 - interpreting results, 223–224
 - program functioning, 219
 - program output, 222–223
 - system simulation, 220
 - time- and frequency-domain analysis, 171, 219, 223–224
 - Condensers, synchronous
 - constants, 88
 - loss-of-field relaying, 216
 - modeling, 88
 - short-circuit studies, 173
 - Conductance, 45
 - Conductors
 - aluminum, 60–61, 391
 - constants, 60–64
 - inductive reactance, 62–63
 - resistance, 60–62
 - shunt capacitive reactance, 63–64
 - copper, 60–61, 391–393, 461
 - effective resistance, 60
 - galvanized steel, 61
 - temperature adjustment factor (F_t), 391–393
 - Constant admittance model (lighting and electric heating loads), 97–98
 - Constant impedance model (induction motors), 87
 - Constant load model (induction motors), 83, 85
 - Coordination studies. *See* Protective coordination studies
 - Copper conductors, 60–61, 391–393, 461. *See also* Conductors
 - Copy protection, definition of, 122
 - CPU (central processing unit), definition of, 122
 - Cramer's rule, 112
 - C-type filter, 282, 284
 - Current method of bus voltage determination for motor-starting, 243–244
 - Current transformers (CTs), 362, 430
 - Cursor, definition of, 123
- ## D
- Damping, 318
 - curves, 324–325, 328
 - resistors, 334–335, 339
 - DC decrement, 168–169, 174–176, 178–179
 - DC motors, 456–459
 - motor control circuits, 461
 - short-circuit characteristics, 457–459
 - voltage and power characteristics, 456–457
 - DC power system studies, 445–466
 - analytical procedures, 446
 - application of dc power system analysis, 445–446
 - load flow or voltage drop studies, 461–464
 - battery terminal voltage, 463–464
 - load profile, 463
 - overview, 12, 445
 - short-circuit studies, 464–466
 - international guidance on, 466
 - system modeling, 446–461

- battery characteristics. *See* Battery characteristics
- battery chargers, 455–456
- branches, 460–461
- motors. *See* DC motors
- Deep bar motor rotor design, 240, 280
- Default, definition of, 123
- Determinants, 111
- Diagonal elements, 104
- Differential equations, 120–121
- Digital computers, 1–2, 7, 43, 103, 140. *See also* Computer solutions and systems
- Dimension, matrix, definition of, 104
- Disconnected buses, 138
- Disconnect switches, 378
- Disk (disc), definition of, 123
- Distribution and transmission systems, transient recovery voltage, 356
- Disturbance data requirement for stability studies, 222
- Double-energy transients, 316
- Double line-to-ground faults, 167
- Double squirrel cage motor rotor design, 240, 280
- Duct banks, 396–400
- Dynamic stability, 212–214. *See also* Stability studies

E

- Eigenvalue analysis, 219
- Electric furnace modeling, 98
- Electric heating modeling, 97–98
- Electromagnetic transients program (EMTP), 345–361
 - capacitor bank switching case study, 347–361
 - network and device representation, 345–347
- Element, matrix, definition of, 104
- Element, network
 - active, 46–49
 - passive, 44–46
- Emergency power systems. *See* DC power system studies

- EMTP. *See* Electromagnetic transients program
- Engineering workstations, 125
- Euler’s method, 121
- Even harmonics, 308
- Exciter field voltage (EFV), 253
- Exciter systems, 234, 247, 257
 - models, 95–97
 - stability and, 218
- Expected interruption duration, definition of, 375
- Expert systems, 12
 - definition of, 123
- Exposure time, definition of, 375

F

- Failure, 379
 - definition of, 375–376
 - frequency and expected duration expressions, 381
 - rate, 378
 - definition of, 376
- Failure modes and effects analysis (FMEA), 379
- Faraday’s law, 314
- Fault analysis. *See also* Short-circuit studies
 - industry standards, 172–179
 - quasi-steady-state, 171–172
 - time domain, 171
- Fault clearing time, 228
- Fault current and grid resistance (ground mat studies), 413–414
- Fault current magnitude and duration (ground mat studies), 411–413
- Ferroresonance transients, 10, 355
- Field measurements
 - harmonics, 276–277
 - switching transients, 359–363
 - equipment for measuring transients, 363
 - overview, 359–360, 362
 - signal circuits, terminations, and grounding, 362–363
 - signal derivation, 362
- Filters, 339

- harmonic analysis models, 282–284
 - resonance due to multiple filters, 275–276
 - selection, 305–307
 - single-tuned, 282–283, 302–304, 307
 - First cycle currents, 172–173, 176
 - Fluorescent lighting, 98
 - FMEA (failure modes and effects analysis), 379
 - Forced outage, 379
 - definition of, 376
 - duration, definition of, 376
 - frequency and expected duration expressions, 381
 - rate, 378
 - definition of, 376
 - Forced unavailability, definition of, 376
 - Fourier representation, 21–22
 - Fourth-order Runge-Kutta method, 121
 - Frequency-domain analysis, 219, 223–224
 - Fromlich's approximation, 253
 - F_t (ambient and conductor temperature), 391–393
 - Fuses, 378, 431, 435
- G**
- Galvanized steel conductors, 61
 - Gauss-Seidel method, 112, 115–118, 141–146, 148, 462
 - Generators
 - armature capacitance to ground, 368
 - buses, 138, 143
 - constants, 366, 368
 - data
 - load flow studies, 139
 - motor-starting studies, 239
 - harmonic analysis models, 277–278
 - hunting phenomena, 226
 - lightning and switching surge response, 355
 - modeling, 87–88, 277–278
 - motor starting solution procedure and example, 245–256
 - pullout protection, 216
 - steady-state torque equation, 212–213
 - transient reactance, 245–246
 - turbine, constants for, 366, 368
 - waterwheel, constants for, 366, 368
 - X/R ratio, 373
 - Governor models, 97
 - Graphical user interface (GUI), definition of, 123
 - Grids (ground mat studies)
 - geometry, 414–415
 - modeling, 415–418
 - Ground-fault current coordination study, 433
 - Ground mat studies, 407–423
 - advanced grid modeling, 415–418
 - benchmark problems, 418–419
 - input/output techniques, 420–424, 426
 - justification, 407
 - modeling the human body, 407–410
 - overview, 11, 407, 420–423
 - sample problem, 420, 425–428
 - traditional analysis, 410–415
 - fault current and grid resistance, 413–414
 - fault current magnitude and duration, 411–413
 - grid geometry, 414–415
 - ground resistivity, 410–411
 - Grouped cables, 395–400
 - GUI (graphical user interface), definition of, 123
- H**
- Hardware, 124–126. *See also* Computer solutions and systems
 - Harmonic analysis, 265–308
 - examples, 290–302
 - general theory, 268–276
 - effects of harmonics, 269–270
 - harmonic sources, 268–269
 - resonance. *See* Resonance
 - overview, 9–10, 265–267
 - purpose, 267–268
 - remedial measures, 302–307
 - filter selection, 305–307
 - standards, harmonic, 307–308
 - system modeling, 276–290

- data for analysis, 289–290
 - filter models, 282–284
 - generator model, 277–278
 - harmonic generation, 286–287
 - induction motor model, 278–281
 - for industrial and commercial systems, 287–289
 - load model, 278, 281
 - network modeling and computer-based solution techniques, 282, 284–286
 - shunt capacitor, 279
 - transformer model, 278–279
 - transmission line and cable models, 279, 281–282
- H* constant (stability studies), 93–94
- Heat flow analysis (cable), 383–386
- High-pass filters, 282–284
- Horsepower to kVA conversion (motor-starting studies), 240
- Human body, modeling, 407–410
- Hunting phenomena (generators), 226
- I**
- IAS (Industry Application Society), 307
- IEC 60909 standard, 177–179
- IEEE (Institute of Electrical and Electronics Engineers), 1
- Industry Application Society (IAS), 307
 - Power Engineering Society (PES), 305, 308
- standards
- cable ampacity studies, 388, 404
 - coordination studies, 431, 433, 444
 - dc power system studies, 445–446, 449, 463
 - ground mat studies, 413–415, 423
 - harmonics, 266–267, 269, 286, 288, 305, 307–309
 - load flow studies, 149, 161, 163
 - motor-starting studies, 233, 239, 252, 263
 - reliability evaluation, 377–378
 - short-circuit studies, 166, 172–179, 203, 206
 - stability studies, 95–96
 - switching transient studies, 357, 366–367
- Impedance, 45, 227, 239
- data requirement for stability studies, 221
 - dc decrement and, 168–169
 - diagram, 53–54
 - induction motors, 180
 - method of bus voltage determination for motor-starting, 242–243
- Independent power producers (IPPs), 209
- Inductance, 55, 313–314
- between capacitor banks, 369
- Induction motors
- impedance values, 180
 - models
 - constant impedance model, 87
 - constant load model, 83, 85
 - harmonic analysis, 278–281
 - overview, 81–84
 - short-circuit studies, 85–87, 173
 - reactance values, 174–175
 - X/R* ratio, 374
- Inductive reactance, 62–63
- Inductive susceptance, 45
- Industrial power systems. *See* Power systems analysis
- Industry Application Society (IAS), 307
- Infinite utility systems, 54
- Initial short-circuit current, 177
- Inrush control reactors, 339
- Inrush current, 241, 247–248
- Inrush motors, 236
- Instability. *See also* Stability studies
- problems caused by, 216
 - system disturbances that produce, 216
- Institute of Electrical and Electronics Engineers. *See* IEEE
- Instrument transformer capacitance, 367
- Interactive computer programs, 127. *See also* Computer solutions and systems
- Interharmonics, 308
- Interrupting currents, 172–173
- Interrupting equipment, 176–177
- Interruption, definition of, 376
- Interruption frequency, definition of, 376
- IPPs (independent power producers), 209
- Iron-core reactors, 307

- Isolated systems, 54
- Iterative solution algorithms, 115–120, 141–142
 - Gauss-Seidel technique, 112, 115–118, 141–146, 148
 - Newton-Raphson technique, 118–120, 141, 146–149, 462

- K**
- K, definition of, 123
- Kirchoff's law, 11, 108–109, 133, 282, 316, 384
- Kvar for capacitor banks, 221, 306

- L**
- Laplace expansion, 112
- Laplace transform, 22–29, 120, 315–323, 336–337
- LC transients, 316
- Lighting modeling, 97–98
- Lightning, switching surge response to, 355
- Linearity, 14–15
- Line dropping, restrike phenomena during, 356
- Lines
 - definition of, 55
 - energizing and reclosing transients, 356
 - models, 55–59
 - long lines, 57–58
 - medium lines, 58–59
 - short lines, 58–59
- Line-to-line faults, 167
- Load flow studies, 133–163
 - bus voltage determination for motor starting, 243–245
 - dc power systems, 446–448, 461–464. *See also* DC power system studies
 - constant current loads, 447–448
 - constant power loads, 447–448
 - constant resistance loads, 447–448
 - example, 151–161
 - input data, 137–140
 - branch data, 139–140
 - bus data, 138–139
 - generator data, 139
 - system data, 137
 - transformer data, 140
 - load buses, 138, 143, 221
 - load flow analysis, 149–151
 - overview, 7–8, 133–134, 162–163
 - programs, 162
 - solution methods, 140–149
 - comparison, 149
 - Gauss-Seidel iterative technique, 112, 115–118, 141–146, 148, 462
 - Newton-Raphson iterative technique, 118–120, 141, 146–149, 462
 - problem formulation, 141
 - system representation, 134–137
- Loads, nonlinear, 265–268, 276
 - proliferation of, 265, 267
- Long line models, 57–58
- Loops, 107
- Loss-of-field relaying, 216

- M**
- M, definition of, 123
- Mainframes, 126
- Maintenance outages, 378–379
- Matrix algebra
 - fundamentals, 104–107
 - power systems, 107–110
- Matrix sparsity, 183
- Mat studies. *See* Ground mat studies
- Medium line models, 58–59
- Mercury vapor lighting, 98
- Mesh, 107
 - ground mat studies, 414–415, 417–419, 426–427
- Microprocessor, definition of, 123
- Minicomputers, 126
- Modeling
 - human body, 407–410
 - power system. *See* System modeling
- Modem, definition of, 123
- Momentary currents, 172
- Monitor, definition of, 123

- Motors
- acceleration time analysis, 236–239, 248, 253–262
 - dc. *See* DC motors
 - impedances, 180
 - induction. *See* Induction motors
 - lightning and switching surge response, 355
 - NEMA design specifications, 232–233
 - pullout protection, 216
 - salient-pole, reactance constants, 366
 - speed-torque analysis, 221–222, 236–239, 248, 253–262
 - starting. *See* Motor-starting studies
 - synchronous. *See* Synchronous machine models
 - trend to become increasingly larger, 231
- Motor-starting studies, 231–262
- data requirements, 238–241
 - basic information, 238–240
 - simplifying assumptions, 240–241
 - dc motors, 456–457
 - need for, 231–235
 - problem revelation, 231
 - special torque requirements, 234–235
 - voltage dips, 231–233
 - weak source generation, 233–234
 - overview, 8–9, 231, 259
 - recommendations, 235–237
 - starting requirements, analyzing, 236–237
 - voltage dips, 235–236
 - solution procedures and examples, 241–262
 - mathematical relationships, 242–249
 - simple voltage drop method, 249–251
 - speed-torque and motor-accelerating time analysis, 236–239, 248, 253–262
 - time-dependent bus voltages, 251–253
 - types of studies, 237–238
 - adaptations, 238
 - detailed voltage profile, 238
 - speed-torque and acceleration time analysis, 236–239, 248, 253–262
 - voltage drop snapshot, 237–238
- Multipulsing, 287–288, 303
- Mutual coupling in zero sequence
short-circuit studies, 181
- N**
- National Electrical Code (NEC), 166, 383, 388, 460
- National Electrical Manufacturers Association (NEMA), 445
motor design specifications, 232–233
- Neher-McGrath conductor ampacity method, 383–384, 386–387
- Networks
- harmonic analysis models, 282, 284–286
 - reduction, 110
- Neutral grounding (short-circuit studies), 180–181
- Newton-Raphson iterative technique, 118–120, 141, 146–149, 462
- Nodes, 54, 107
- Non-integer harmonics, 308
- Nonlinear loads, 176, 265–268
proliferation of, 265, 267
- Norton equivalent circuit, 19
- Norton impedance, 266
- Numerical solution techniques, 104–121
- differential equations, 120–121
 - matrix algebra fundamentals, 104–107
 - power system network matrices, 107–110
 - simultaneous algebraic equations. *See* Simultaneous algebraic equations, solution of
- O**
- Odd harmonics, 308
- Off-diagonal elements, 104
- Ohm’s law, 11, 283, 313–314, 384
- Operating system, definition of, 123
- Oscillographs, 363
- Oscilloscopes, 363
- Outage, definition of, 376
- Outdoor bushing capacitance to ground, 365
- Out-of-step operation, 216

- Overcurrent protective devices. *See* Protective coordination studies
- Overfrequency, 225
- Overhead lines, 55
cables, compared to, 60
- P**
- Parallel resonance, 272–275
- Partitioning, matrix, 106–107, 110
- Passive network elements, 44–46
- PCC (point of common coupling), 287–290, 308
- PCs (personal computers), 125, 441–443.
See also Computer solutions and systems
- “Peakpickers,” 363
- Peak short-circuit current, 177
- Personal computers (PCs), 125, 441–443.
See also Computer solutions and systems
- Per-unit method, 38–40, 71–73
- PES (Power Engineering Society), 305, 308
- PF. *See* Power factor
- Phase bus capacitance, 369
- Phase overcurrent coordination study, 433
- Phase-shifting transformer models, 70–71
- Phasors, 20–21, 171
- Pixel (pel), definition of, 124
- Point of common coupling (PCC), 287–290, 308
- “Post-mortem” analysis, 166–167
- Potential transformers (PTs), 362
- Potier reactance, 222
- Power company. *See* Utilities
- Power Engineering Society (PES), 305, 308
- Power factor (PF), 47, 306
correction capacitors, 270, 275–276, 302
harmonic filter design and, 266
motor during starting, 241
- Power quantities, defining expressions for, 47
- Power system data development, 71–79
per-unit representations, 71–79
applications example, 73–79
- Power systems analysis
application to industrial and commercial power systems, 2, 7
cable ampacity studies. *See* Cable ampacity studies
coordination studies. *See* Protective coordination studies
DC auxiliary power system analysis. *See* DC power system studies
digital computers, 7. *See also* Computer solutions and systems
ground mat studies. *See* Ground mat studies
harmonic analysis studies. *See* Harmonic analysis
history of, 1–2
load flow studies. *See* Load flow studies
most common system studies, 3–5
motor-starting studies. *See* Motor-starting studies
overview, 1–5
preparing for, 2–3
recommended practice, purposes of, 2–5
reliability studies. *See* Reliability studies
short-circuit studies. *See* Short-circuit studies
stability studies. *See* Stability studies
switching transient studies. *See* Switching transient studies
transient network analyzer (TNA), 7, 10, 276, 338, 340–345
- Power system stabilizer (PSS), 218, 228
- Power transformers (PTs), 430
reactance, 364
- Prime mover models, 97
- Protective coordination studies, 429–444
basics, 430–434
computer programs, 435–443
common structure, 436–441
coordination programs, 435, 441–443
TCC plotting programs, 435, 441
equipment needs, 443
overview, 11–12, 429–430, 444
verifying the results, 443
- PSS (power system stabilizer), 218, 228
- PTs (potential transformers), 362
- Pullout protection (generators), 216

Q

- Q factor, 307
- Quasi-steady-state fault analysis, 171–172

R

- RAM (random access memory), definition of, 124
- Reactance
 - power transformers, 364
 - synchronous machines, 366
- Reactive power, 47
- Reactors, 306, 307
 - air-core, 307
 - modeling, 64
 - shunt, 98, 340
 - tuning, 339
 - X/R ratio and resistance, 372
- Recommended practice
 - most common system studies, 3–5
 - purposes of, 2–5
- Rectifiers, 265
- Regulators, 221, 234, 247, 257
- Relays, 431, 435
- Reliability studies, 375–381
 - data needed, 377–378
 - definitions, 375–377
 - method, 378–381
 - failure modes and effects analysis (FMEA), 379
 - service interruption definition, 379
 - overview, 10, 375
 - system reliability indexes, 377
- Repair time, definition of, 376
- Resistance, 55, 60–62, 313–314
- Resistivity, soil, 388, 393–395, 410–411, 413–414, 421
- Resonance, 270–276
 - due to multiple filters, 275–276
 - parallel, 272–275
 - series, 270–273
- Restrike phenomena (switching transient analysis), 356
- Reversed phase rotation (switching transient analysis), 356

- RLC circuits, 318–323, 338
- ROM (read-only memory), definition of, 124
- Rotating machines
 - data requirement for stability studies, 221–222
 - design and selection of, 217
- Rotation, equations for, 49
- Rotor angle, 212–215
- Row matrix, 104
- Row vector, 104
- Runge-Kutta method, 121

S

- Salient-pole motor constants, 366
- SCADA (Supervisory Control And Data Acquisition) systems, 133
- Scale modeling, 43
- Scheduled outage, 378–379
 - definition of, 376
 - duration, definition of, 376
 - rate, definition of, 377
- Secondary arc (transient network analyzer), 341
- Series capacitors, 64. *See also* Capacitors
- Series faults, 167–168
- Series inductance, 55
- Series resistance, 55
- Series resonance, 270–273
- Servers, 125–126
- Service interruption method 379
- Shock hazards. *See* Ground mat studies
- Short-circuit studies, 85–87, 165–205. *See also* Fault analysis
 - accuracy, factors affecting, 179–182
 - mutual coupling in zero sequence, 181
 - neutral grounding, 180–181
 - phase shifts in delta wye transformer banks, 181–182
 - prefault system loads and shunts, 181
 - system configuration, 179
 - system impedances, 179–180
- batteries, 449–455
- battery chargers, 456
- computational approaches, 171–172

- quasi-steady-state fault analysis, 171–172
- time domain fault analysis, 171
- computer solutions, 182–186
 - software, 184–186
 - system matrices, 182–183
- dc power systems, 447, 464–466
 - international guidance on, 466
 - motors, 457–459
- example, 187–203
- extent and requirements, 166–168
- fault analysis according to industry standards, 172–179
- international standard IEC 60909 (1988), 177–179
- North American ANSI and IEEE standards, 172–179
 - ac and dc decrement, 174–176, 178–179
 - calculating short-circuit currents and interrupting equipment, 176–177
- overview, 8, 12, 165–166
- synchronous machines, 89–93
- system modeling, 168–171
 - ac decrement and rotating machinery, 168
 - dc decrement, 168–169
 - system configuration, 179
 - system impedances, 168–171, 179–180
 - system loads, 181
 - three-phase *versus* symmetrical components, 169–170
- Short line models, 58–59
- Shunt reactors, 98
 - transient network analyzer (TNA), 340
- Shunts
 - capacitance, 55
 - capacitive reactance, 63–64
 - capacitor modeling, 98, 279
 - conductance, 55–57
 - faults, 167
 - reactor modeling, 98, 340
 - short-circuit studies, 181
- Simultaneous algebraic equations, solution of, 110–120
 - direct methods, 111–115
 - iterative methods, 115–120, 141–142
 - Gauss-Seidel technique, 112, 115–118, 141–146, 148, 462
 - Newton-Raphson technique, 118–120, 141, 146–149, 462
 - overview, 110–111
- Single-line diagram, 3–4
- Single line-to-ground faults, 167
- Single-phase equivalent circuit, 29–31
- Single-tuned filters, 282–283, 302–304, 307.
 - See also* Filters
- Sinusoidal forcing function, 19–20
- Skin effect, 280
- Software, 126–129, 162. *See also* Computer solutions and systems
- Soil
 - resistivity, 410–411, 413–414, 421
 - temperature, 384–385, 391
 - thermal resistivity, 388, 393–395
- Speed-torque analysis, 221–222, 236–239, 248, 253–262
- Square matrix, 104
- Stability studies
 - fundamentals, 209–215
 - definition of stability, 209
 - multimachine systems, 215
 - steady-state stability, 210–212
 - transient and dynamic stability, 212–214
 - two-machine systems, 215
 - industrial power systems, 223, 225–228
 - co-gen plant that imports power from local utility, 226–227
 - co-gen plant with excess generation, 225–226
 - oscillations between industrial power plant and utility system, 227–228
 - instability
 - problems caused by, 216
 - system disturbances that produce, 216
 - most complex type of study, 8
 - overview, 8, 209, 228
 - solutions to stability problems, 217–218
 - design and selection of rotating equipment, 217
 - power system stabilizer application, 218
 - system design, 217

- system protection, 218
- voltage regulator and exciter characteristics, 218
- synchronous machines, 92–97
 - classical, 93
 - exciters, 95–97, 218. *See also* Exciter systems
 - governors, 97
 - H constant, 93–94
 - prime movers, 97
 - variations, 94–95
- system stability analysis, 218–223
 - data requirements, 221–222
 - disturbances, simulation of, 220–221
 - interpreting results, 223–224
 - program functioning, 219
 - program output, 222–223
 - system simulation, 220
 - time- and frequency-domain analysis, 219, 223–224
- Standby power systems. *See* DC power system studies
- Starting, motor. *See* Motor-starting studies
- Static power converters as harmonics source, 265
- Static var systems (transient network analyzer), 341
- Steady-state fault current, 177–178
- Steady-state stability, 210–212. *See also* Stability studies
 - definition of, 8
- Steady-state torque equation, 212–213, 215
- Step potential, 408–409
- Stiff utility systems, 54
- Super-minicomputers, 126
- Superposition, 15–16
- Supervisory Control And Data Acquisition (SCADA) systems, 133
- Surge arresters, 339, 341
- Surge capacitors, 339
- Swing buses, 138, 143
- Switching time, definition of, 377
- Switching transient studies, 313–374
 - capacitor bank switching examples
 - electromagnetic transients program (EMTP), 347–361
 - transient network analyzer (TNA), 341–345
 - circuit parameters, typical, 363–374
 - cable charging current, 373
 - generator armature capacitance to ground, 368
 - inductance between capacitor banks, 369
 - instrument transformer capacitance, 367
 - outdoor bushing capacitance to ground, 365
 - phase bus capacitance, 369
 - power transformer reactance, 364
 - synchronous machine constants, 366
 - transformer winding capacitance to ground, 371
 - transmission line characteristics, 370
 - X/R ratio and resistance of reactors, 372
 - X/R ratio of generators, 373
 - X/R ratio of induction motors, 374
 - X/R ratio of transformers, 374
 - control of switching transients, 339
 - electromagnetic transients program (EMTP), 345–361
 - capacitor bank switching case study, 347–361
 - network and device representation, 345–347
 - field measurements, 359–363
 - equipment for measuring transients, 363
 - overview, 359–360, 362
 - signal circuits, terminations, and grounding, 362–363
 - signal derivation, 362
 - general description, 313–338
 - analytical techniques, 315
 - circuit elements, 313–315
 - examples, 325–334
 - normalized damping curves, 324–325
 - overview, 313, 337–338
 - transient analysis based on the Laplace transform method, 24–29, 315–323
 - transient recovery voltage (TRV), 334–337

- objectives, 338–339
 - overview, 10, 338, 352–353
 - problem areas, 353, 355–358
 - transient network analyzer (TNA), 340–345
 - capacitor bank switching case study, 341–345
 - Symmetrical component analysis, 32–37, 170
 - Symmetric matrix, 104
 - Synchronous condensers
 - constants, 366
 - loss-of-field relaying, 216
 - modeling, 88
 - short-circuit studies, 173
 - Synchronous machine models, 87–97
 - constants, 366
 - generators, 87–88, 173
 - short-circuit models, 89–93, 167, 173
 - stability models, 92–97
 - classical, 93
 - data requirement, 221–222
 - exciters, 95–97, 218. *See also* Exciter systems
 - governors, 97
 - H constant, 93–94
 - prime movers, 97
 - variations, 94–95
 - synchronous condensers, 88
 - synchronous motors, 88–89
 - impedance values, 180
 - modeling, 88–89
 - pullout protection, 216
 - short-circuit studies, 173
 - torque *versus* rotor angle, 213
 - transient network analyzer (TNA), 341
 - System, definition of, 377
 - System modeling
 - branch element modeling, 55–71
 - cables, 59–60. *See also* Cable
 - capacitors, 64. *See also* Capacitors
 - constants. *See* Conductors, constants
 - lines, 55–59. *See also* Lines
 - reactors, 64. *See also* Reactors
 - transformers. *See* Transformers, models
 - bus elements, 80–98
 - electric furnaces, 98
 - induction motors. *See* Induction motors, models
 - lighting and electric heating, 97–98
 - loads in general, 80–81
 - shunt capacitors, 98
 - shunt reactors, 98
 - synchronous machines. *See* Synchronous machine models
 - digital computers, 43. *See also* Computer solutions and systems
 - extent of model, 54
 - isolated systems, 54
 - utility supplied systems, 54
 - impedance, 53–54, 168–171, 179–180
 - overview, 43
 - power network solution, 49–53
 - power system data development, 71–79
 - applications example, 73–79
 - per-unit representations, 71–79
 - reactors. *See* Reactors
 - review of basics, 44–49
 - active elements, 46–49
 - passive elements, 44–46
 - scale modeling, 43
 - short-circuit studies, 168–171. *See also* Short-circuit studies
 - ac decrement and rotating machinery, 168
 - dc decrement, 168–169
 - system configuration, 179
 - system impedances, 168–171, 179–180
 - system loads, 181
 - three-phase *versus* symmetrical components, 169–170
 - System protection and power system stability, 218
 - System reliability indexes, 377. *See also* Reliability studies
 - System separation (industrial power plant and utility), 228
- ## T
- TCCs. *See* Time-current characteristics curves
 - Telephone interference, 9

- telephone interference factor (TIF), 285
 - Terminal, definition of, 124
 - Thermal overload heaters, 461
 - Thermal resistivity (F_{th}), 393–395
 - Thevenin equivalent circuit, 16–19, 175–176
 - Three-circuit transformer models, 67–70
 - Three-phase faults, 167, 181
 - analysis, 171
 - simulation, 220
 - Throwover switches, 378
 - TIF (telephone interference factor), 285
 - Time-current characteristics curves (TCCs), 429–430, 433–436, 441
 - plotting programs, 435, 441
 - Time delayed currents, 172–174
 - Time-dependent bus voltages (motor starting), 251–253
 - Time-domain analysis, 171, 219
 - Time-sharing services, 124
 - TNA (transient network analyzer), 7, 10, 276, 338, 340–345
 - capacitor bank switching case study, 341–345
 - Torque
 - equation, 212–213, 215
 - motor starting, 234–235, 238
 - speed analysis, 257–260
 - Touch potential, 408–409
 - Transformers
 - current, 362, 430
 - data
 - coordination studies, 431
 - load flow studies, 140
 - motor-starting studies, 239
 - stability studies, 221
 - instrument, capacitance of, 367
 - lightning and switching surge response, 355
 - line-to-ground short-circuit currents and, 167
 - models, 65–71
 - harmonic analysis, 278–279
 - phase-shifting transformers, 70–71
 - three-circuit transformers, 67–70
 - transformer taps, 67
 - two-circuit transformers, 65–66
 - phase shifts in delta wye transformer banks, 181–182
 - potential, 362
 - reactance, 364
 - short-circuit studies, 173
 - taps, 67
 - transient network analyzer (TNA), 340–341
 - winding capacitance to ground, 371
 - X/R ratio, 374
 - Transient network analyzer (TNA), 7, 10, 276, 338, 340–345
 - capacitor bank switching case study, 341–345
 - Transient recovery voltage (TRV), 334–337
 - distribution and transmission systems, 356
 - Transients, 216–217
 - studies. *See* Switching transient studies
 - Transient stability, 212–214. *See also* Stability studies
 - definition of, 8
 - Translation, equations for, 48–49
 - Transmission lines
 - characteristics, 370
 - harmonic analysis models, 279, 281–282
 - transient network analyzer (TNA), 340
 - Transmission towers
 - lightning and switching surge response, 355
 - TRV (transient recovery voltage), 334–337
 - distribution and transmission systems, 356
 - Tuning reactors, 339
 - Turbine generator constants, 366, 368
 - Two-circuit transformer models, 65–66
- ## U
- Unavailability, definition of, 377
 - Undamped high-pass filter, 283
 - Underfrequency, 226
 - Utilities, 54
 - co-gen plant that imports power from local utility, 226–227

- data requirements for motor-starting studies, 239
- infinite, 54
- oscillation between industrial plant and utility, 224, 227–228
- point of common coupling (PCC), 287–290, 308
- power factor, 270
- reactance values, 174–175
- separating industrial system from, 216
- short-circuit capacity data for stability studies, 221
- stiff, 54

V

- Ventricular fibrillation, 407–408
- Voltage dips (motor starting), 231–233, 235–236
- Voltage drop studies
 - dc systems, 461–464
 - motor starting, 237–238, 249–251
- Voltage flicker
 - switching transient analysis, 356
- Voltage profile (motor starting), 238
- Voltage regulators and stability, 218

- Voltage stabilizers, 236
- Voltmeters, 363

W

- Waterwheel generators
 - constants, 366, 368
- Watt-hour meter error, 9
- Winding capacitance to ground, 371
- Word, definition of, 124
- Workstation, engineering, 125

X

- X/R ratio
 - generators, 373
 - induction motors, 374
 - resistance of reactors and, 372
 - transformers, 374

Y

- Y-matrix, 182–183