

IEEE Guide for Identification, Testing, and Evaluation of the Dynamic Performance of Excitation Control Systems

Sponsor
**Excitation Systems Subcommittee
of the
Power Generation Committee
of the
IEEE Power Engineering Society**

Approved May 31, 1990
IEEE Standards Board

Abstract: IEEE Std 421.2-1990, *IEEE Guide for Identification, Testing, and Evaluation of the Dynamic Performance of Excitation Control Systems*, presents dynamic performance criteria, definitions, and test objectives for excitation control systems as applied by electric utilities. It should be specifically noted that the term “excitation control system” refers to the entire control system including the synchronous machine and power system as well as the excitation system.

Keywords: Closed-loop performance, excitation control systems, excitation system specifications, large signal disturbances, small signal disturbances

ISBN 1-55937-053-X

Copyright © 1990 by

The Institute of Electrical and Electronics Engineers, Inc.

345 East 47th Street, New York, NY 10017-2394, USA

No part of this publication may be reproduced in any form, in an electronic retrieval system or otherwise, without prior permission of the publisher.

IEEE Standards documents are developed within the Technical Committees of the IEEE Societies and the Standards Coordinating Committees of the IEEE Standards Board. Members of the committees serve voluntarily and without compensation. They are not necessarily members of the Institute. The standards developed within IEEE represent a consensus of the broad expertise on the subject within the Institute as well as those activities outside of IEEE which have expressed an interest in participating in the development of the standard.

Use of an IEEE Standard is wholly voluntary. The existence of an IEEE Standard does not imply that there are no other ways to produce, test, measure, purchase, market, or provide other goods and services related to the scope of the IEEE Standard. Furthermore, the viewpoint expressed at the time a standard is approved and issued is subject to change brought about through developments in the state of the art and comments received from users of the standard. Every IEEE Standard is subjected to review at least every five years for revision or reaffirmation. When a document is more than five years old, and has not been reaffirmed, it is reasonable to conclude that its contents, although still of some value, do not wholly reflect the present state of the art. Users are cautioned to check to determine that they have the latest edition of any IEEE Standard.

Comments for revision of IEEE Standards are welcome from any interested party, regardless of membership affiliation with IEEE. Suggestions for changes in documents should be in the form of a proposed change of text, together with appropriate supporting comments.

Interpretations: Occasionally questions may arise regarding the meaning of portions of standards as they relate to specific applications. When the need for interpretations is brought to the attention of IEEE, the Institute will initiate action to prepare appropriate responses. Since IEEE Standards represent a consensus of all concerned interests, it is important to ensure that any interpretation has also received the concurrence of a balance of interests. For this reason IEEE and the members of its technical committees are not able to provide an instant response to interpretation requests except in those cases where the matter has previously received formal consideration.

Comments on standards and requests for interpretations should be addressed to:

Secretary, IEEE Standards Board
445 Hoes Lane
P.O. Box 1331
Piscataway, NJ 08855-1331
USA

IEEE Standards documents are adopted by the Institute of Electrical and Electronics Engineers without regard to whether their adoption may involve patents on articles, materials, or processes. Such adoption does not assume any liability to any patent owner, nor does it assume any obligation whatever to parties adopting the standards documents.

Foreword

(This Foreword is not a part of IEEE Std 421.2-1990, IEEE Guide for Identification, Testing, and Evaluation of the Dynamic Performance of Excitation Control Systems.)

This guide presents dynamic performance criteria, definitions, and test objectives for excitation control systems as applied by electric utilities. It should be specifically noted that the term excitation control system refers to the entire control system including the synchronous machine and power system as well as the excitation system.

The Working Group on Excitation Control System Dynamic Performance of the Excitation Systems Subcommittee of the Power Generation Committee adopted many definitions and performance criteria, which are common to all control systems, and derived others specifically related to excitation control systems. In doing this, the material in IEEE Std 421.1-1986, IEEE Standard Definitions for Excitation Systems for Synchronous Machines (ANSI) and IEEE Std 100-1988, IEEE Standard Dictionary of Electrical and Electronics Terms (ANSI) was heavily used. Efforts were made not to conflict with existing definitions and criteria, but to clarify, supplement, and more fully define them as related specifically to excitation control systems. Definitions from these standards, which are reproduced in this standard, are set in italics in Section 3.

In preparing this guide, the working group recognized that both factory testing and field testing of excitation control systems and some of their components are costly and often impractical. Alternator-rectifier excitation systems in which the terminals of the exciter may not be available may preclude field testing of the exciter separately. Compound source excitation systems whose power is derived from the generator currents and voltages present special difficulties. Providing a load which reasonably duplicates the generator field characteristics so that regulation effects and proper waveforms can be adequately simulated may not be economically justifiable. Field tests on units under normal operating conditions are constrained to comply with the operating and security requirements of the power system, which often prohibit large excursions of the excitation control system variables. For many applications, it is necessary to devise practical test procedures for individual components and then by analytical means, to verify the total excitation system performance.

The need for models that accurately simulate the operation of excitation control systems during system disturbances demands effective test methods. However, the practical limitations on tests make it difficult to measure the parameters required for models. One solution is the collection of more complete data during system disturbances. Present instrumentation practices generally do not include the collection of data from enough excitation control system variables to permit the data to be used for model refinement. Improving the quantity and quality of data collected during system disturbances may be the only practical way to obtain the data required to significantly improve the accuracy of large signal models.

This revision incorporates the changes in IEEE Std 421.1-1986, IEEE Standard Definitions for Excitation Systems for Synchronous Machines (ANSI), which substituted a single definition, excitation system nominal response, for several previous definitions that included the phrase “response ratio.” Root locus techniques applicable to excitation control system performance evaluation are added in this revision. The material in IEEE Std 421A-1972, IEEE Guide for Identification, Testing, and Evaluation of the Dynamic Performance of Excitation Control Systems (ANSI), pertaining to power system stabilizers is retained. However, the IEEE Tutorial on Power System Stabilization Via Excitation Control (81EH0175-0 PWR) provides substantial supplemental material. The previous material related to synchronizing and damping torques is omitted.

The following members of the IEEE Power Generation Committee balloted and approved this guide for submission to the IEEE Standards Board:

M. S. Baldwin
I. B. Berezowsky
L. D. Boydston
G. R. Brockschink
J. B. Cannon

R. W. Cantrell
R. L. Castleberry
E. F. Chelotti
R. E. Cotta
M. L. Crenshaw

P. L. Dandeno
P. M. Davidson
K. J. Dhir
D. Diamant
G. Engmann

W. B. Gish
D. I. Gorden
R. K. Gupta
J. H. Gurney
J. D. Hurley
J. H. Jones
C. E. Kneeburg
S. B. Kuznetsov
P. Landrieu
R. A. Lawson
D. C. Lee

P. A. Lewis
J. E. LeClair
J. T. Madill
O. S. Mazzoni
G. R. Meloy
M. W. Migliaro
D. H. Miller
D. R. McCabe
L. G. Ottobre
R. E. Penn III
C. R. Pope

R. J. Reiman
J. R. Ribeiro
D. E. Roberts
E. P. Rothong
J. E. Stoner, Jr.
L. A. Tauber
I. Trebinovic
T. R. Whittemore
R. Zweigler

Members of the Working Group of the Excitation Systems Subcommittee, which formulated the 1978 standard, were:

F. W. Keay, Chair

K. E. Bollinger
R. T. Byerly
M. L. Crenshaw
P. L. Dandeno*
C. W. Drake
L. E. Eilts

G. T. Heydt
R. A. Lawson
D. C. Lee
J. F. Luini
G. R. Meloy
R. G. Pillote

C. Raczkowski
N. W. Simons
G. I. Stillman
M. Temoshok

*Liaison from the Power System Engineering Committee

Members of the Working Group of the Excitation Systems Subcommittee, which revised this standard, were:

T. R. Whittemore, Chair

M. L. Crenshaw
P. L. Dandeno*
K. J. Dhir
R. G. Farmer*
W. B. Gish

D. I. Gorden
J. H. Gurney
J. D. Hurley
R. A. Lawson
D. C. Lee

G. R. Meloy
D. H. Miller
J. R. Ribeiro
L. A. Tauber
I. Trebinovic

*Liaison from the Power System Engineering Committee

When the IEEE Standards Board approved this standard on May 31, 1990, it had the following membership:

Marco W. Migliaro, Chair
James M. Daly, Vice Chair
Andrew G. Salem, Secretary

Dennis Bodson
Paul L. Borrill
Fletcher J. Buckley
Allen L. Clapp
Stephen R. Dillon
Donald C. Fleckenstein
Jay Forster*
Thomas L. Hannan

Kenneth D. Hendrix
John W. Horch
Joseph L. Koepfinger*
Irving Kolodny
Michael A. Lawler
Donald J. Loughry
John E. May, Jr.
Lawrence V. McCall

L. Bruce McClung
Donald T. Michael*
Stig Nilsson
Roy T. Oishi
Gary S. Robinson
Terrance R. Whittemore
Donald W. Zipse

*Member Emeritus

CLAUSE	PAGE
1. Introduction	1
1.1 Scope	1
1.2 References	2
1.3 Definitions	3
2. Dynamic Performance Classification.....	3
2.1 Large Signal Performance.....	3
2.2 Small Signal Performance.....	4
3. Large Signal Performance Criteria	4
3.1 General	4
3.2 Ceiling Current.....	4
3.3 Ceiling Voltage	5
3.4 Excitation System Voltage Time Response	5
3.5 Excitation System Voltage Response Time	5
3.6 High Initial Response.....	5
3.7 Excitation System Nominal Response	6
3.8 Transient Responses.....	7
4. Small Signal Performance Criteria	8
4.1 General	8
4.2 Transient Response	8
4.3 Frequency-Response Characteristic (Linear System)	8
4.4 Complex Frequency Domain (S-plane)	12
4.5 Small Signal Performance Indexes	12
5. Excitation Control System Stability.....	16
5.1 Types of Synchronous Machine Oscillations.....	16
5.2 Application of Power System Stabilizers.....	19
6. Large Signal Performance Testing.....	21
6.1 General	21
6.2 Factory Testing	22
6.3 Field Testing	22
6.4 Fault Testing	25
6.5 Power System Disturbances.....	25
7. Small Signal Performance Testing.....	26
7.1 Excitation Control System Components	26
7.2 Field Testing	27
7.3 Field Testing with Power System Stabilizers	28
Annex A (Informative) Basis Underlying the Concept of Nominal Response.....	31
Annex B (Informative) Frequency Response Characteristics of Typical Excitation Control System Elements.....	34

IEEE Guide for Identification, Testing, and Evaluation of the Dynamic Performance of Excitation Control Systems

1. Introduction

1.1 Scope

This guide includes criteria, definitions, and test objectives for evaluating the dynamic performance of excitation control systems as applied by electric utilities. The term “excitation control system” (see Fig 1) is used to distinguish the combined performance of the synchronous machine, power system, and excitation system from that of the excitation system alone (see IEEE Std 100-1988, IEEE Standard Dictionary of Electrical and Electronics Terms (ANSI) [1]¹ and IEEE Std 421.1-1986, IEEE Standard Definitions for Excitation Systems for Synchronous Machines (ANSI) [2]). The primary purpose of this guide is to provide a basis for evaluating closed-loop performance of excitation control systems for both large and small signal disturbances; confirming the adequacy of mathematical models of excitation control systems for use in analytical studies of power systems; identifying objectives for tests of excitation control systems and their components; and preparing excitation system specifications and additional standards. Portions of this guide will also serve as educational material for people who are becoming acquainted with excitation control systems.

Traditionally, large signal performance (see 2.1) has been more closely associated with equipment specification and acceptance testing, while small signal performance (see 2.2) has been more closely associated with stability and model studies. Matching actual disturbance data with model simulations requires that both large and small signal performance criteria be considered during design specification and acceptance testing.

¹IEEE publications are available from the Institute of Electrical and Electronics Engineers, IEEE Service Center, 445 Hoes Lane, Piscataway, NJ 08855-1331. The numbers in brackets refer to the references listed in 1.2.

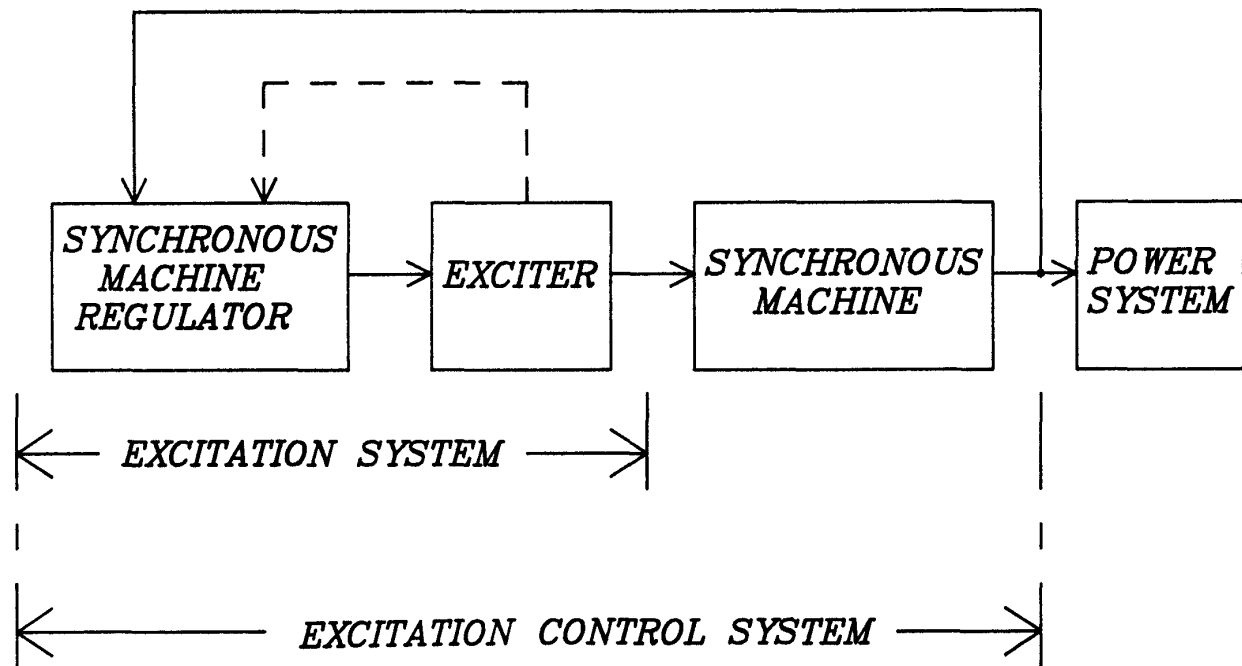

Figure 1—Block Diagram of an Excitation Control System

1.2 References

This guide shall be used in conjunction with the following publications:

- [1] IEEE Std 100-1988, IEEE Standard Dictionary of Electrical and Electronics Terms (ANSI).
- [2] IEEE Std 421.1-1986, IEEE Standard Definitions for Excitation Systems for Synchronous Machines (ANSI).
- [3] Byerly, R. T. and Kimbark, E. W., eds., *Stability of Large Electric Power Systems*, New York: IEEE Press, 1974.
- [4] Dandeno, P. L., Kundur, P., Poray, A. T., and Zein El-Din, H. M. Adaptation and Validation of Turbogenerator Model Parameters Through On-Line Frequency Response Measurements, *IEEE Transactions on Power Apparatus and Systems*, vol. PAS-100, no. 3, Apr. 1981, pp. 1658-1664.
- [5] DeMello, F. P. and Concordia, C. Concepts of Synchronous Machine Stability as Affected by Excitation Control, *IEEE Transactions on Power Apparatus and Systems*, vol. PAS-88, Apr. 1969, pp. 316-329.
- [6] Farmer, R. G. and Agrawal, B. L. State-of-the-Art Technique for Power System Stabilizer Tuning, *IEEE Transactions on Power Apparatus and Systems*, vol. PAS-102, Mar. 1983, pp. 699-709.
- [7] Gerheart, A. D., Hillesland, T., Jr., Luini, J. F., and Rockfield, M. L., Jr. Power System Stabilizer: Field Testing and Digital Simulation, *IEEE Transactions on Power Apparatus and Systems*, vol. PAS-90, Sept./Oct. 1971, pp. 2095-2100.
- [8] Hurley, J. D. and Baldwin, M. S. High-Response Excitation Systems on Turbine-Generators: A Stability Assessment, *IEEE Transactions on Power Apparatus and Systems*, vol. PAS-101, no. 6, Nov. 1982, pp. 4211-4221.

- [9] IEEE Committee Report. Excitation System Dynamic Characteristics, *IEEE Transactions on Power Apparatus and Systems*, vol. PAS-92, no. 1, Jan./Feb. 1973, pp. 64–75.
- [10] IEEE Committee Report. Excitation System Models for Power System Stability Studies, *IEEE Transactions on Power Apparatus and Systems*, vol. PAS-100, no. 2, Feb. 1981, pp. 494–509.
- [11] IEEE Tutorial, Power System Stabilization Via Excitation Control, 81EH0175-0 PWR, 1980.
- [12] Kundur, P., Lee, D. C., and Zein El-Din, H. M. Power System Stabilizers for Thermal Units: Analytical Tests and On-Site Validation, *IEEE Transactions on Power Apparatus and Systems*, vol. PAS-100, Jan. 1981, pp. 81–95.
- [13] Larsen, E. V. and Swann, D. A. Applying Power System Stabilizers, *IEEE Transactions on Power Apparatus and Systems*, vol. PAS-100, Jun. 1981, pp. 3017–3041.
- [14] Warchol, E. J., Schleif, F. R., Gish, W. B., and Church, J. R. Alignment and Modeling of Hanford Excitation Control for System Damping, *IEEE Transactions on Power Apparatus and Systems*, vol. PAS-90, Mar./Apr. 1971, pp. 714–724.
- [15] Watson, W. and Coultres, M. E. Static Exciter Stabilizing Signals on Large Generators—Mechanical Problems, *IEEE Transactions on Power Apparatus and Systems*, vol. PAS-92, Jan./Feb. 1973, pp. 204–211.

1.3 Definitions

ceiling current: The maximum direct current that the excitation system is able to supply from its terminals for a specified time.

ceiling voltage: The maximum direct voltage that the excitation system is able to supply from its terminals under defined conditions.

system nominal response: The rate of increase of the excitation system output voltage determined from the excitation system voltage response curve, divided by the rated field voltage. This rate, if maintained constant, would develop the same voltage-time area as obtained from the actual curve over the first half-second interval (unless a different time interval is specified).

excitation system voltage response time: The time in seconds for the excitation voltage to attain 95% of the difference between ceiling voltage and rated field voltage under specified conditions.

excitation system voltage time response: The excitation system output voltage expressed as a function of time under specified conditions.

frequency-response characteristic (linear system): In a linear system, the frequency-dependent relation, in both gain and phase difference, between steady-state sinusoidal inputs and the resultant steady-state sinusoidal outputs.

large signal performance: The response to signals that are large enough so that nonlinearities are significant.

power system stabilizer: An element or group of elements that provide an additional input to the regulator to improve the dynamic performance of the power system.

small signal performance: The response to signals that are small enough so that nonlinearities are insignificant.

2. Dynamic Performance Classification

2.1 Large Signal Performance

Large signal performance is the response to signals that are large enough so that nonlinearities are significant.

The purpose of large signal performance criteria is to provide a means of evaluating excitation system performance for severe transients that may include large variations in synchronous machine stator voltages, synchronous machine stator currents, and induced synchronous machine field currents; that is, for transients affecting system transient stability. To assess the ability of the excitation system to improve synchronous machine performance, the criteria must reflect the effects of operation under realistic power system disturbances. With respect to performance testing, it is often impractical to adequately duplicate these effects. In cases where tests can only be made on individual components and only at partial load or open-circuit, analytical means may be used to predict performance under actual operating conditions.

The criteria that assess the large signal performance are quantities such as transient responses, ceiling currents and voltages, voltage response times, and nominal responses derived from time responses (see IEEE Std 100-1988, IEEE Standard Dictionary of Electrical and Electronics Terms (ANSI) [1] and IEEE Std 421.1-1986, IEEE Standard Definitions for Excitation Systems for Synchronous Machines (ANSI) [2]).

2.2 Small Signal Performance

Small signal performance is the response to signals which are small enough that nonlinearities are insignificant. Small signal performance of an excitation control system or its components can be assessed from time responses, frequency responses, or by eigenvalue analysis (see References [9], [10], and [11]).

Small signal performance criteria provide a means of evaluating the response of systems for incremental load changes, incremental voltage changes, and the incremental changes in synchronous machine rotor speed associated with the initial stages of dynamic instability (where oscillations are small enough so that nonlinearities are insignificant). Small signal performance data provide a means for determining or verifying excitation system model parameters for system studies (see References [4] and [8]). The assumption of linearity limits the application of small signal models as noted above.

3. Large Signal Performance Criteria

3.1 General

The following large signal performance criteria relate to excitation control systems and, where applicable, their components. To permit maximum flexibility in the design, manufacture, and application of excitation equipment, some of the performance criteria are defined “under specified conditions.” The applicable conditions may be specified by the manufacturer or, more usually, by the equipment purchaser.

The general nature of several of the following definitions, notably field current and field voltage, permit them to be used to achieve different objectives in different applications. As a result, confusion can also result when they are applied inconsistently. Care must be exercised that the “under specified conditions” clauses are interpreted in a manner consistent with the application.

3.2 Ceiling Current

The maximum direct current which the excitation system is able to supply from its terminals for a specified time (see IEEE Std 100-1988, IEEE Standard Dictionary of Electrical and Electronics Terms (ANSI) [1]).

When sustained overloads or prolonged disturbances are of concern, the ceiling current may be based upon the excitation system thermal duty that identifies the maximum output current and the required time duration. For some applications, the ceiling current will be determined by the requirement that the synchronous machine produce a specific value of steady-state, three-phase, short-circuit current for a specified time.

When a high value of ceiling voltage is required for forcing action, exciter current limiter control circuits may determine the actual ceiling current.

3.3 Ceiling Voltage

The maximum direct voltage that the excitation system is able to supply from its terminals under defined conditions (see IEEE Std 100-1988, IEEE Standard Dictionary of Electrical and Electronics Terms (ANSI) [1]).

Ceiling voltage can be used to evaluate the forcing capability of the excitation system to drive the field current toward the ceiling current value. The ceiling voltage provides an indication of the voltage available to force the field current from rated field current toward ceiling current. The greater the difference between the ceiling voltage and the rated field voltage, the greater the forcing capability. Higher ceiling voltages tend to improve transient stability.

The excitation system ceiling voltage under load may be determined by either a steady-state or transient measurement. It may be determined in a steady-state measurement with the excitation system loaded with a resistance such that ceiling current is attained but not exceeded. It is necessary that the load have adequate inductance so that voltage drop effects, and current and voltage waveforms are reasonably duplicated. It is determined with the exciter output current limiter control circuits inactive. If a transient determination is made, then adequate inductance is required in the load so that the ceiling voltage is measurable at ceiling current before any current limiters operate. The no-load ceiling voltage is determined with the excitation system open-circuited.

For potential source and compound source excitation systems, whose supply depends on the synchronous machine voltage and current, the nature of power system disturbances and specific design parameters of the excitation control system influence the excitation system output. For such systems, the ceiling voltage is defined based upon a specified supply voltage and (if applicable) current.

For excitation systems employing a rotating exciter, the ceiling voltage is determined at rated speed.

Some excitation systems will have both positive and negative values of ceiling voltage. Also, in some special applications, the excitation system may be required to supply both positive and negative field current to the synchronous machine.

3.4 Excitation System Voltage Time Response

The excitation system output voltage expressed as a function of time under specified conditions (see Fig 2 and IEEE Std 100-1988, IEEE Standard Dictionary of Electrical and Electronics Terms (ANSI) [1]).

3.5 Excitation System Voltage Response Time

The time in seconds for the excitation voltage to attain 95% of the difference between ceiling voltage and rated field voltage under specified conditions (see IEEE Std 100-1988, IEEE Standard Dictionary of Electrical and Electronics Terms (ANSI) [1]).

3.6 High Initial Response

For those systems with very short response time relative to the generator field time constant and to power system characteristic swings, the shape of the initial response is not of concern. Those systems whose voltage response time 0.1 second or less are termed “high initial response excitation systems.”

3.7 Excitation System Nominal Response

The rate of increase of the excitation system output voltage determined from the excitation system voltage response curve, divided by the rated field voltage. This rate, if maintained constant, would develop the same voltage-time area as obtained from the actual curve over the first half-second interval (unless a different time interval is specified) (see IEEE Std 100–1988, IEEE Standard Dictionary of Electrical and Electronics Terms (ANSI) [1]). Nominal response is used as a figure of merit related to the ability of an excitation system to respond to transient stability issues and to permit comparisons of excitation systems. The basic underlying concept of nominal response, as related to power system stability, is developed in Appendix A. The half-second interval was selected to associate the nominal response with the excitation system contribution to stability.

The starting point for determining the nominal response is the time the disturbance is initiated; that is, the excitation system nominal response should include any delay time that may be present. Referring to Fig 2, the excitation system nominal response is illustrated by line ac. This line is determined by establishing $\text{area acd} = \text{area abd}$.

Nominal response is determined by initially operating the excitation system at rated field current of the synchronous machine and then suddenly creating the three-phase terminal voltage input signal conditions necessary to drive the excitation system voltage to ceiling (see IEEE Std 100–1988, IEEE Standard Dictionary of Electrical and Electronics Terms (ANSI) [1]). If nominal response is used as a figure of merit for comparing different types of excitation systems, misleading results may be obtained if different types of limiters or differing values of inductance are permitted. Nominal response determinations from actual time responses obtained by recording responses during disturbances may be misleading when compared with factory tests because of the influence of fault induced currents.

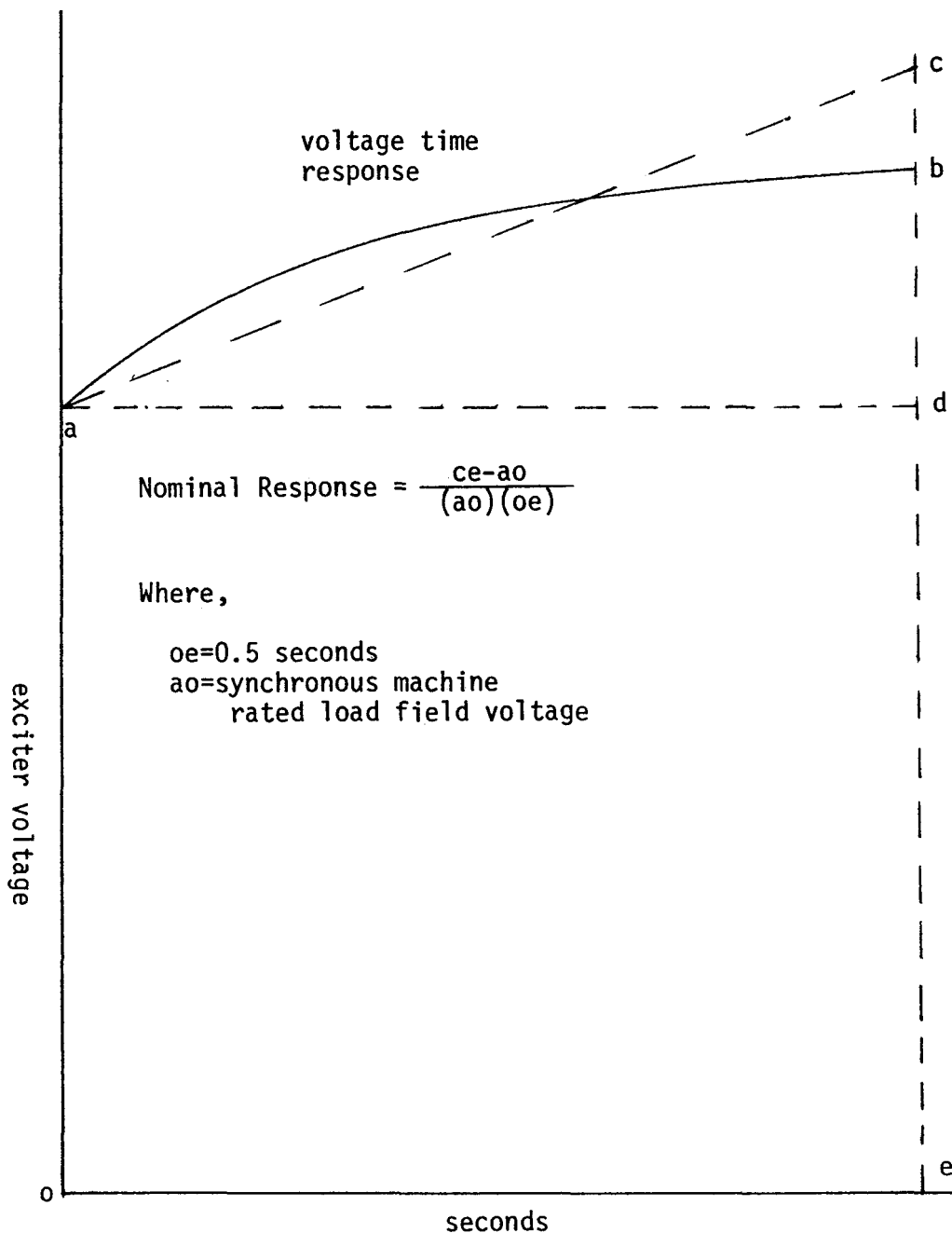

Figure 2—Excitation System Nominal Response

3.8 Transient Responses

Many of the large signal performance criteria provide a single numerical value. Excitation system ceiling voltage and nominal response are two examples. These criteria are useful for comparing performance of different systems, and they are valuable as design criteria that can be used to verify that the manufacturer fulfilled specification requirements. However, these single value criteria do not provide sufficient information in all instances for model parameter selection or verification. A specific response can be achieved in models with different combinations of model parameters. This ambiguity can be reduced by comparing model results with time responses. Although transient

response (see 4.2) is more frequently associated with small signal analysis, it is a useful criteria for large signal performance evaluation, especially for applications involving the refinement or validation of computer models.

Any portion of the excitation control system that is commonly represented in model studies (e.g., synchronous machine regulator, exciter, synchronous machine, excitation system, and excitation control system) may be evaluated using the transient response criteria.

A large signal transient response is a time response with the input and output variables of the component being tested recorded as a function of time. Although transient response is generally associated with a step change in the input variable, it is only necessary that the change in the input variable be large enough and fast enough that the response at the output is classified as a large signal response for the resulting response to be useful. The change to the input variable must be specified. A time response with several variables recorded simultaneously has considerable value in the refinement or validation of large signal computer models.

4. Small Signal Performance Criteria

4.1 General

While the large signal performance criteria can be applied to the excitation control system, individual components of the system, or the excitation system, the small signal performance criteria are commonly used to evaluate the performance of closed-loop excitation control systems.

4.2 Transient Response

A typical transient response of a feedback control system is shown in Fig 3. The principal characteristics of interest are the rise time, overshoot, and settling time as indicated.

4.3 Frequency-Response Characteristic (Linear System)

In a linear system, the frequency-dependent relation, in both gain and phase difference, between steady-state sinusoidal inputs and the resultant steady-state sinusoidal outputs (see IEEE Std 421.1-1986, IEEE Standard Definitions for Excitation Systems for Synchronous Machines [2]). Typical opened-loop frequency response characteristics of an excitation control system with the synchronous machine open-circuited are shown in Fig 4. The principal characteristics of interest are the low frequency gain G , crossover frequency (ω_c), phase margin ϕ_m , and gain margin G_m . The corresponding closed-loop frequency response is shown in Fig 5. Here the parameters of interest are the bandwidth ω_B , the peak value M_p of the gain characteristic, and the frequency ω_m at which the peak value occurs.

Opened-loop frequency response characteristics are useful in determining gain and phase margins, both of which are measures of relative stability. Relative stability of a closed-loop control system can be determined from the properties of the Bode plot of the opened-loop transfer function. However, this method can be used only if the opened-loop transfer function has no poles and zeroes in the right half S-plane (minimum phase characteristics).

Relative stability of a feedback control system is measured in terms of the gain and phase margins. For a minimum phase system, which is stable with the feedback loop open, the gain and phase margins must be positive in order for the system to be stable with the feedback loop closed. Negative gain and phase margins mean that the system will be unstable with the feedback loop closed. In general, a gain margin of 6 dB or more and a phase margin of 40° or more is recommended for most feedback control systems.

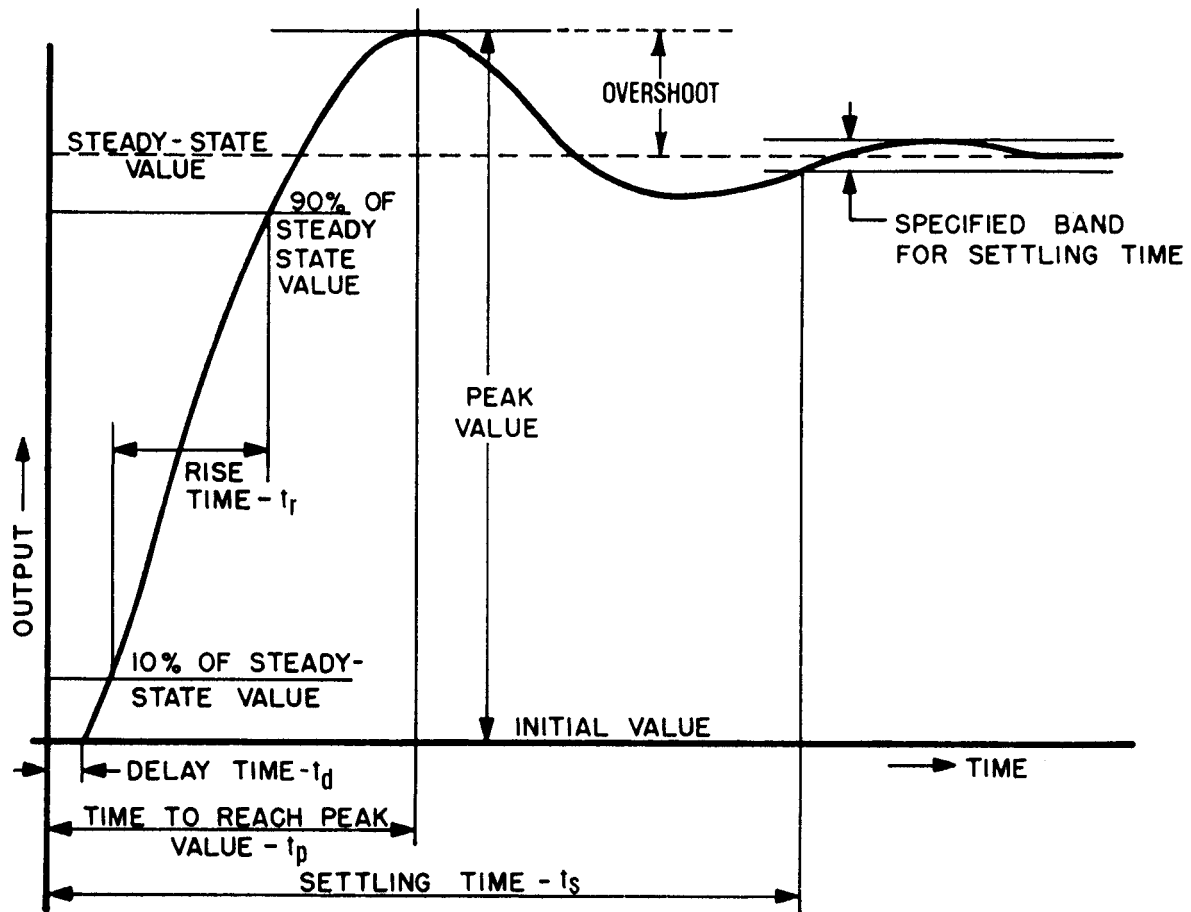

Figure 3—Typical Transient Response of a Feedback Control System to a Step Change in Input

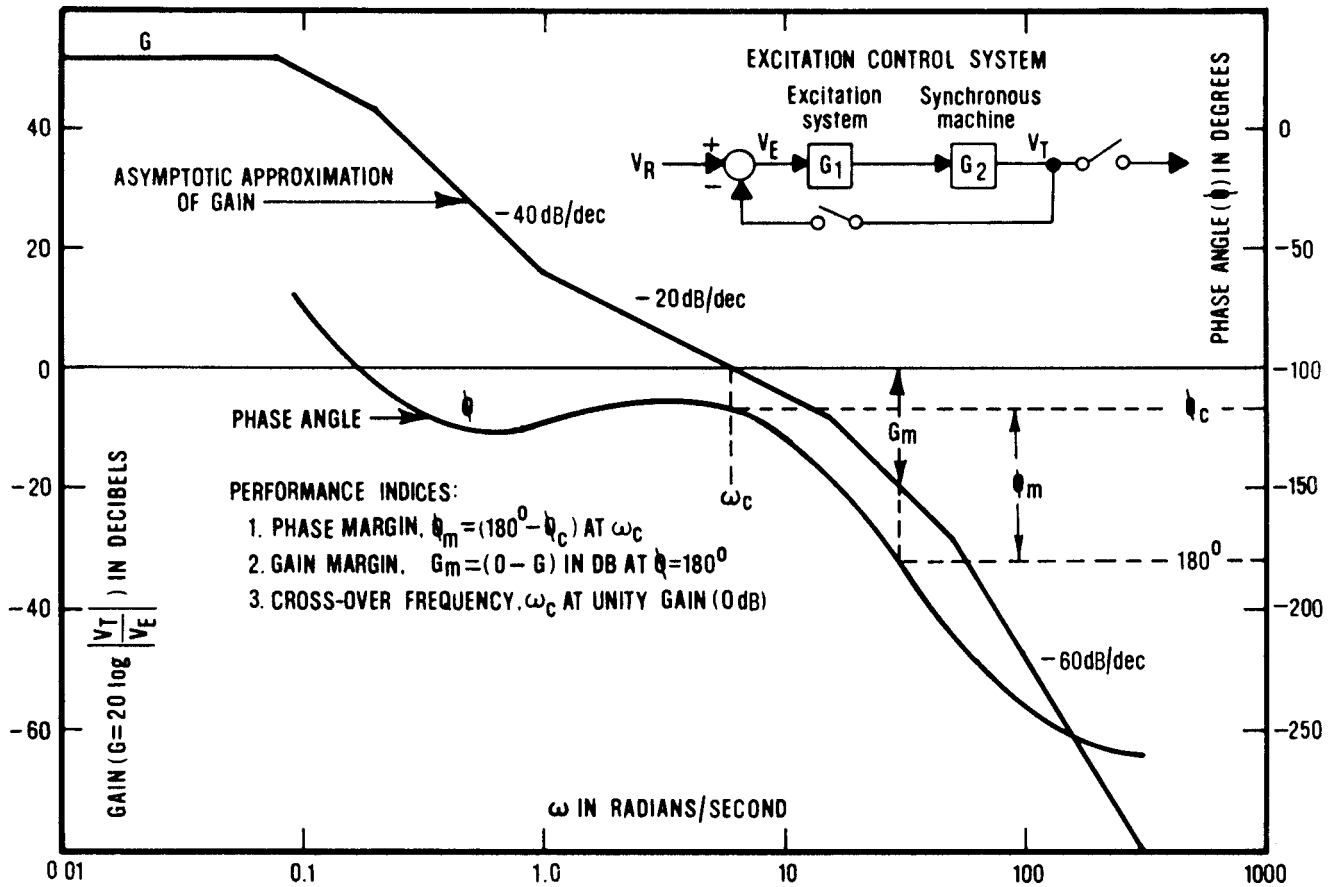

Figure 4—Typical Open-Loop Frequency Response of an Excitation Control System with the Synchronous Machine Open-Circuited

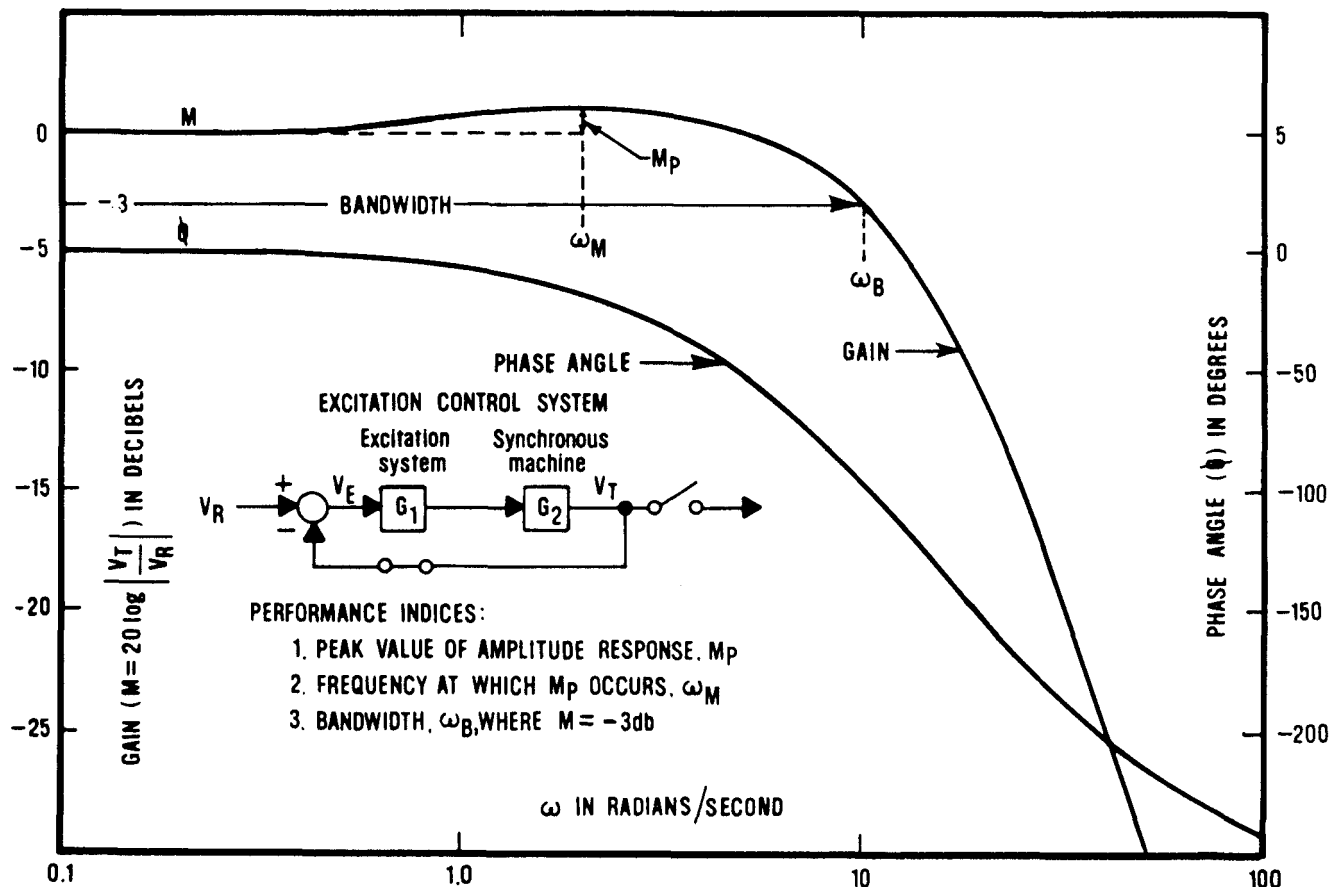

Figure 5—Typical Closed-Loop Frequency Response of an Excitation Control System with the Synchronous Machine Open-Circuited

The process of determining stability of non-minimum phase (poles and zeroes in the right half S-plane) and conditionally stable systems is relatively more involved and beyond the scope of this guide. A conditionally stable system is said to be stable for a given range of values of gain but becomes unstable if the gain is either reduced or increased sufficiently. Normally, conditionally stable systems should be avoided whenever possible.

With respect to the closed-loop frequency response characteristics, the peak value M_p (in decibels (dB)) of the amplitude response is also a measure of relative stability. A high value of M_p (> 1.6 dB) is indicative of an oscillatory system exhibiting large overshoot in its transient response. In general, $1.1 \text{ dB} \leq M_p \leq 1.6 \text{ dB}$ is considered good design practice for most feedback control systems.

Bandwidth ω_B is a significant closed-loop frequency response performance index because it is indicative of the rise time T_r or speed of the transient response of the system; it measures, in part, the ability of the system to reproduce input signals. In feedback control systems having a step response exhibiting less than 10% overshoot, rise time T_r in seconds is related to bandwidth ω_B in hertz by the approximate relationship:

$$T_{r\omega B} = 0.30 \text{ to } 0.45$$

In general, the product $T_{r\omega B}$ increases as the overshoot in the system transient response increases; values in the range of 0.3 to 0.35 correspond to negligible overshoot; values in the region of 0.45 correspond to systems with about 10% overshoot. The effects of excitation system bandwidth as it relates to various types of synchronous machine oscillations are discussed in 5.1.

4.4 Complex Frequency Domain (S-plane)

The dynamic characteristics of a control system can be represented by mapping the eigen-values (or characteristic roots) of its Laplace transfer function in the complex frequency domain or S-plane. Typical root locations of an excitation control system with the terminal voltage feedback loop open and the synchronous machine open-circuited are shown in Fig 6 (see also Reference [13]).

Real roots ($s = \sigma$) are mapped on the horizontal axis of the S-plane. Complex root pairs ($s = \sigma \pm j\omega$) are typically mapped showing only the positive-frequency root ($\sigma + j\omega$), with the negative-frequency root ($\sigma - j\omega$) implied. Roots of the transfer function denominator are poles (each indicated by “X”). Roots of the numerator are zeroes (each indicated by “0”).

Poles that are farther to the left of the $j\omega$ (vertical) axis represent modes which are more quickly damped than those nearer the $j\omega$ axis. Poles that are to the right of the $j\omega$ axis represent unstable modes and, thus, indicate a system which is unstable.

The locations of the opened-loop poles and zeroes in Fig 6 depend upon the dynamic characteristics of transfer functions G_1 and G_2 . Although the loop gain K has no effect on the opened-loop poles and zeroes, it has a large effect on the closed-loop poles.

A root locus plot typically maps the locations of the closed-loop S-plane poles as the loop gain is varied from zero to infinity. Figure 7 shows a root locus of the excitation control system with the opened-loop characteristics of Fig 6. The poles of the closed-loop system are mapped in the S-plane as the value of gain K is varied. At a value of gain $K = 0$, the closed-loop poles are the same as the opened-loop system poles. At a value of gain $K = K_{co}$, complex poles cross over the $j\omega$ axis into the right plane, indicating instability. If the gain K is adjustable, operating gain $K = K_{op}$ can be selected for acceptable gain margin (G_m) and damping ratio (ζ).

Generally accepted values of the performance indexes described above characterizing good feedback control system performance are tabulated in Table 1.

4.5 Small Signal Performance Indexes

It is not possible to define such generally acceptable ranges of values for the other small signal performance indexes: rise time, settling time, and bandwidth. These indexes are measures of relative speed and stability of control action. In most feedback control systems, they are determined primarily by the dynamic characteristic of the system element whose output is the ultimately controlled variable. In the case of an excitation control system, the dynamic characteristics of the synchronous machine (field time constant, etc.) are the determining factors.

It should be noted that simultaneous optimization of all small signal performance indexes is not possible. For example, low M_p , high damping ratio, high gain margin, and high phase margin are not compatible with maximum bandwidth. Those performance indexes that are of primary importance depend on the individual application of each feedback control system, and no universally applicable “best criteria” can be recommended in standards.

Typical ranges of values of small signal performance indexes for an excitation control system are given in Table 2. These data have been derived analytically using the anticipated extreme ranges (longest to shortest) of synchronous machine field time constants and excitation system time constants likely to be encountered.

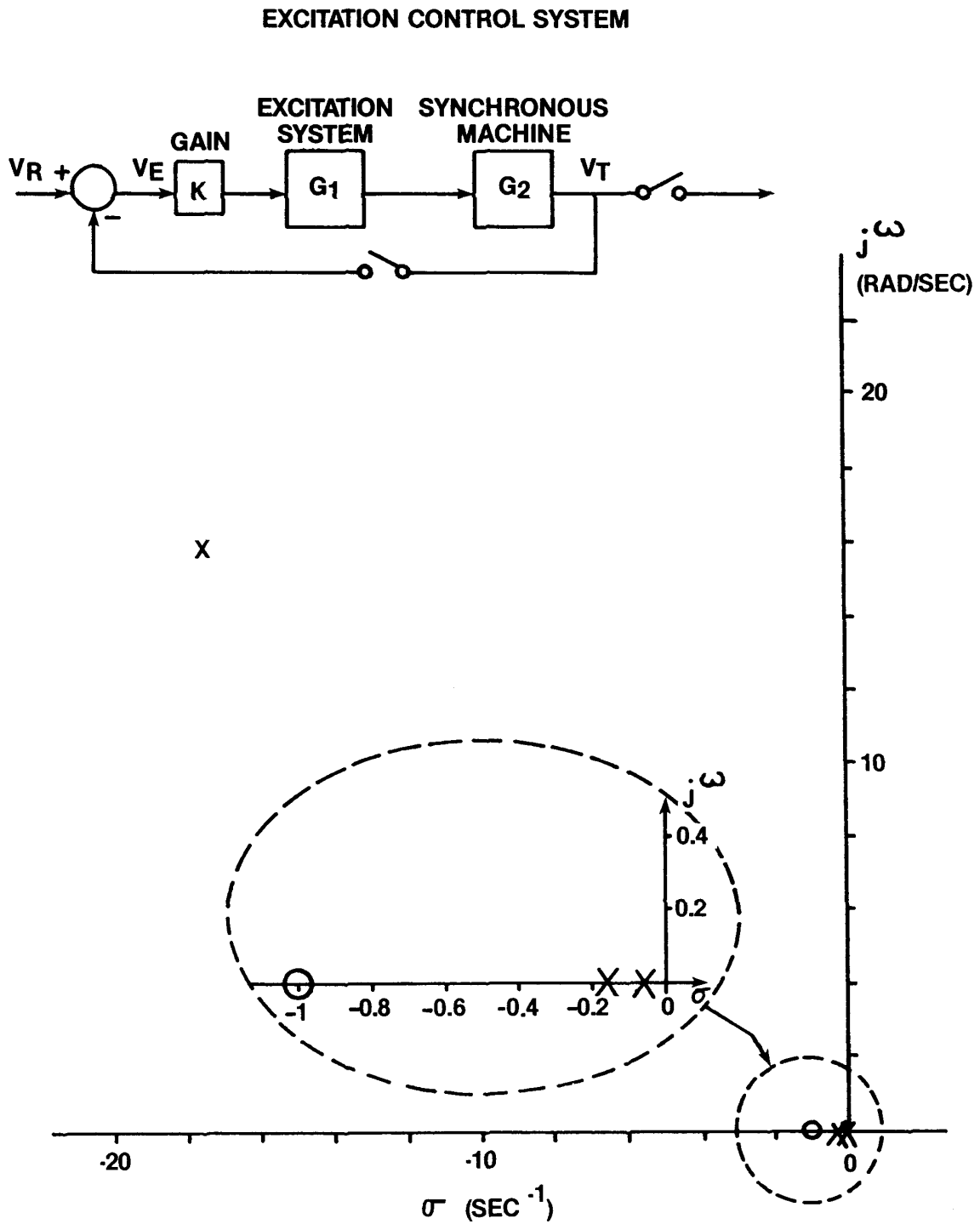

Figure 6—Pole/Zero Plot of a Typical Opened-Loop Excitation Control System with the Synchronous Machine Open-Circuited

EXCITATION CONTROL SYSTEM

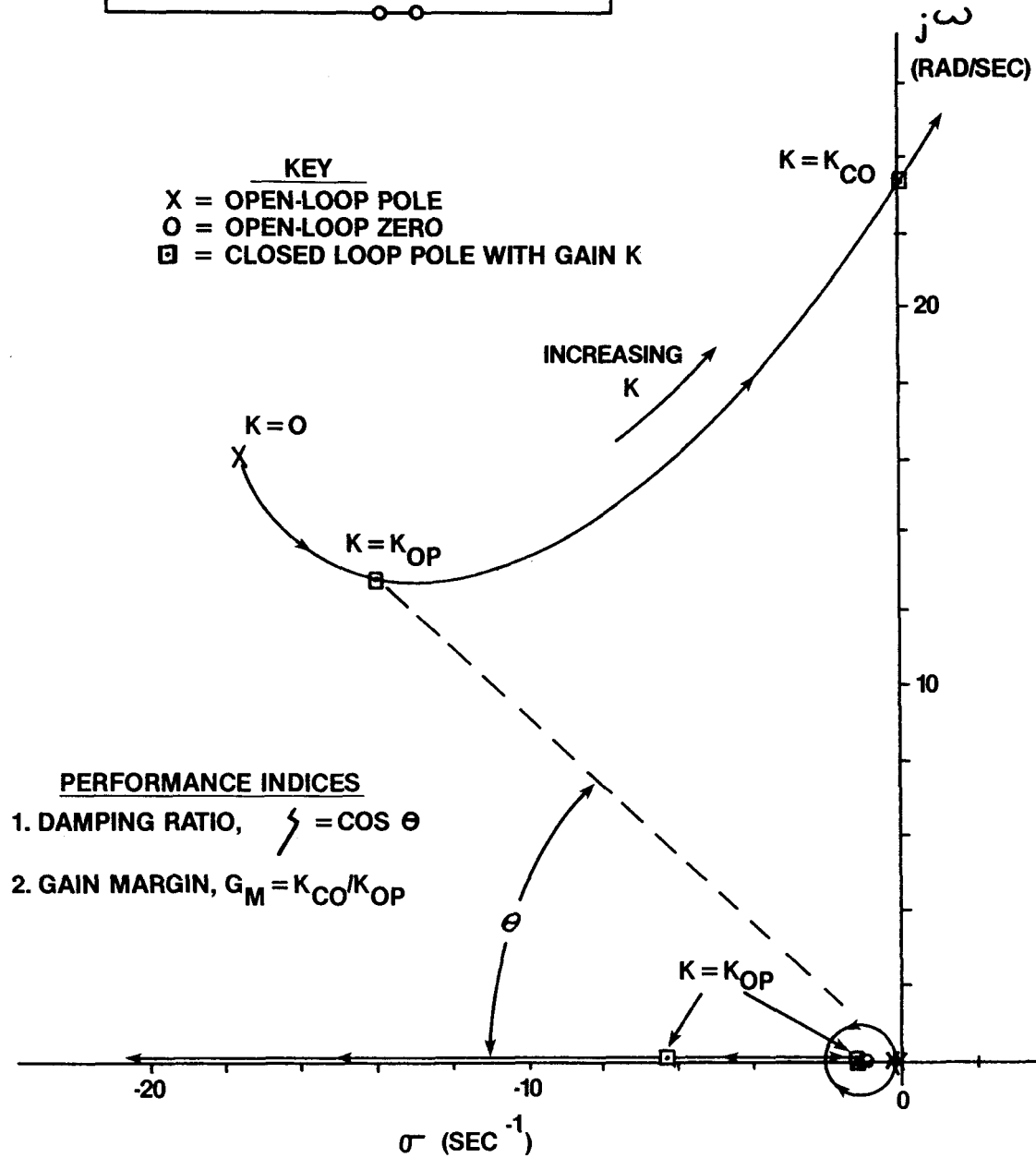
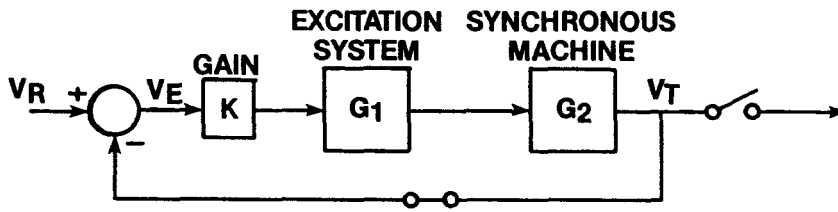

Figure 7—Root Locus Plot of a Typical Closed-Loop Excitation Control System with the Synchronous Machine Open-Circuited as the Gain (K) Is Incremented from Zero to Infinity

Table 1—Generally Accepted Values of Indexes Characterizing Good Feedback Control System Performance

Gain margin	≥ 6 dB
Phase margin	$\geq 40^\circ$
Overshoot	0 to 15%
M_p	1.1 to 1.6 (0.8 dB to 4 dB)
Damping ratio	≥ 0.6

Table 2—Range of Excitation Control System Small Signal Dynamic Performance Indexes

Performance Index	Range of Expected Values
Excitation system gain	30 pu to 800 pu
Gain margin	2 dB to 20 dB
Phase margin	20° to 80°
M_p	1 to 4 (0 to 12 dB)
Bandwidth	0.3 Hz to 12 Hz
Overshoot	0 to 80%
Rise time	0.1 s to 2.5 s
Settling time	0.2 s to 10 s
Damping ratio	0 to 1

The performance indexes in Table 1 are applicable to any feedback control system having a single major feedback loop, that is, a single ultimately controlled variable. As such, they are applicable to an excitation control system with the synchronous machine open-circuited. A loaded synchronous machine connected to a power system is a complex multiloop, multivariable feedback control system.

For a loaded synchronous machine connected to a multimachine interconnected power system, performance indexes such as those in Table 1 lose much of their significance. Analysis and synthesis techniques that are applicable to these types of systems should be used. One approach to assessing the performance of this complex system is to model the system using state-space techniques and calculate the eigenvalues (characteristic equation roots) for the range of excitation system, synchronous machine, and system parameters of interest. The state-space model can be derived from known plant and system parameters, operating conditions, and experimental frequency response data, if the latter is available. The calculation of eigenvalues gives a direct indication of system stability for the linearized system and serves as an efficient initial step before testing the selected parameters in a more extensive study such as a transient stability study. The quadratic performance index and other indexes that utilize the state space-model are measures of the ability of a multiloop control system to meet specified criteria.

When a synchronous machine is connected to a power system, its operating level and the parameters of the external system greatly influence performance. Figure 8 serves to illustrate some of these effects. Figure 8 shows calculated frequency response characteristics and S-plane pole/zero locations of the transfer function $\Delta V_T/\Delta E_{FD}$ for a typical large synchronous machine at three operating points: torque angles of 0° , 72° , and 102° , respectively. The characteristics of Fig 8 are calculated for a synchronous machine connected to an infinite bus through an external reactance with no synchronous machine regulator or governor action. Torque angle depends on machine characteristics, machine operating point, and on the magnitude of external impedance.

Figure 8 shows that the dynamic characteristics of a synchronous machine change dramatically when the torque angle increases. Figure 8(a) shows that an unloaded synchronous machine ($\delta = 0^\circ$) behaves as a simple inductive circuit with a single time constant, corresponding to the time constant of the field circuit. The maximum phase lag is 90° , occurring when the frequency ω reaches infinity. In the S-plane, the machine exhibits a complex pair of poles and zeroes that cancel each other in the $\Delta V_T/\Delta E_{FD}$ transfer function.

Figures 8(b) and 8(c) show frequency responses with characteristic resonant peaks appearing in the gain function accompanied by a sudden dip in the phase angle. These characteristics are attributable to poorly damped complex poles introduced into the transfer function of the synchronous machine by increasing the torque angle.

In the S-plane plots of Fig 8(b) and 8(c), the complex pair of zeroes no longer coincide with the complex pair of poles. In Fig 8(c) ($\delta = 102^\circ$), the S-plane pole/zero plot shows a pole on the positive real axis.

This indicates monotonic instability, as would be expected with an uncontrolled synchronous machine operating beyond 90° torque angle (see Reference [13]). The highly oscillatory characteristics of a synchronous machine operating at high torque angle can readily lead to instability when the machine is operated in a closed-loop feedback control system with a voltage regulator.

It is frequently necessary to apply supplementary control, such as a power system stabilizer, to compensate for these characteristics to ensure stable operation and improve damping of oscillations arising from system disturbances.

5. Excitation Control System Stability

Increasing torque angle or increasing synchronous machine regulator gain reduces stability of the excitation control system. Excitation control system oscillations resulting from an unstable system can have varying frequencies and amplitudes determined by the degree of instability and the nature of the system disturbance. The oscillations may be associated with transient stability and large signal performance or dynamic stability and small signal performance. The material in this section describes various types of oscillations and the application of power system stabilizers (see References [3] and [5]).

5.1 Types of Synchronous Machine Oscillations

The oscillatory characteristics between a synchronous machine and a power system, and among synchronous machines on a power system, should be carefully considered whenever applying excitation controls. If an excitation system in its particular application has the capability of destabilizing any particular mode of oscillation, then supplementary controls may be necessary to prevent or minimize the destabilizing effect. An excitation system may also be called upon to provide damping to oscillatory modes that may already exist on a power system.

Synchronous machine oscillations can often be characterized as falling into one of the four categories described below. Often, the frequency of the oscillation will provide the best indication of which type of oscillation is occurring. For this reason, power plant operators should be instructed to try to note the swing frequency or period of any undamped oscillation whenever it is observed.

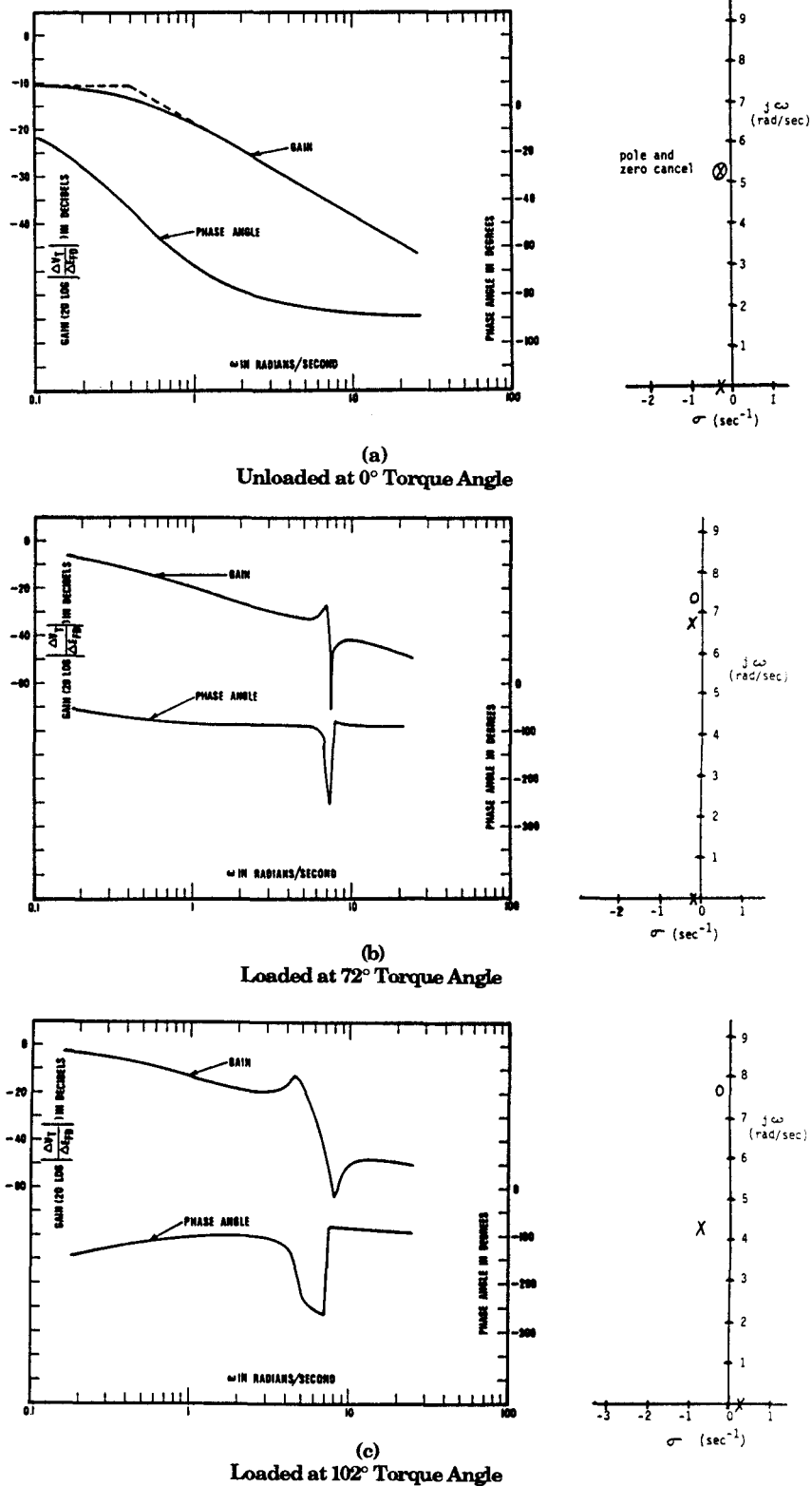

Figure 8—Frequency Response Characteristics and S-plane Pole/Zero Locations of a Typical Synchronous Machine as a Function of Torque Angle, with No Voltage Regulator Action and with No Governor Action

5.1.1 Local Machine-System Oscillations

These oscillations generally involve one or more synchronous machines at a power station swinging together against a comparatively large power system or load center at a frequency in the range of 0.7 Hz to 2 Hz. These oscillations become particularly troublesome when the plant is at high load with a high reactance transmission system.

The use of modern excitation systems with solid-state controls allows faster terminal voltage regulation than was possible with older, more sluggish excitation systems. Although the synchronizing torque coefficient is enhanced as the gain of the synchronous machine regulator is increased in the range of the oscillation frequency, negative damping is introduced into the machine torque-speed loop (see Reference [5]). Depending on the desired gain and the system in which it is employed, local machine-system oscillations may become negatively damped. In order to preserve the high synchronizing torque coefficient and restore the damping torque, power system stabilizers may be used, as described in 5.2.

In general, when a power system stabilizer is not applied, a faster-acting or wider bandwidth excitation system has a greater potential for destabilizing local machine-system oscillations. This often necessitates the application of a power system stabilizer on fast-acting excitation systems. The application of a properly tuned power system stabilizer on most modern normal response or high response excitation systems will contribute positive damping to these types of oscillations. In this case, a wider bandwidth excitation system has the potential to contribute a greater amount of damping, although it has a greater reliance on proper power system stabilizer operation.

5.1.2 Interarea Oscillations

These oscillations usually involve combinations of many synchronous machines on one part of a power system swinging against machines on another part of the system. Interarea oscillations are normally of a much lower frequency (≤ 0.5 Hz) than local oscillations. Therefore, older excitation systems even with a quite sluggish response, as well as the more modern excitation systems, may have the capability of contributing either positive or negative damping to interarea oscillations, depending upon whether or not a power system stabilizer is applied. Since interarea oscillations usually involve many machines, successful damping of such modes may require the application of power system stabilizers on the excitation systems of a large number of machines.

5.1.3 Interunit Oscillations

These oscillations typically involve two or more synchronous machines at a power plant or nearby power plants in which machines swing against each other, usually at a frequency of between 1.5 Hz to 3 Hz. These oscillations can be destabilized with a power system stabilizer, and thus may require consideration in determining power system stabilizer settings.

5.1.4 Torsional Oscillations

These oscillations involve relative angular motion between the rotating elements (synchronous machine, turbines, and exciter) of a unit, with frequencies ranging from 4 Hz and above. This mechanical system has very little inherent natural damping. The source of torque for inducing torsional oscillations with the excitation system comes from a combination of modulation of excitation system output power, and modulation of synchronous machine power due to changes in generator field voltage. Besides the excitation systems, there are other mechanisms that can excite torsional oscillations such as dc lines, series capacitors, static converters, and other devices.

The ability of the excitation system to excite torsional oscillations is enhanced in wider bandwidth excitation systems. A wide bandwidth excitation system may have the capability to provide enough negative damping at any of these torsional natural frequencies to destabilize one or more of these torsional modes, particularly with the application of a power system stabilizer. If the excitation system is powerful enough at the torsional frequency of interest, oscillations may quickly build to a level resulting in damaging stresses in the shafts. Reference [15] vividly illustrates this problem. The problem is compounded by the fact that operators may be unaware that unstable torsional oscillations are occurring because recording and indicating meters may not respond to these frequencies.

Analysis of the effects of excitation control on torsional oscillations generally requires more complex excitation system and synchronous machine models than those necessary for analyzing local machine-system oscillations. Ultimately, tests using instruments capable of responding to torsional frequencies may be necessary to confirm that torsional modes will not be destabilized or that countermeasures, such as notch filters in the power system stabilizer, are acting to reject these oscillations.

5.2 Application of Power System Stabilizers

A power system stabilizer is an element or group of elements that provide an additional input to the regulator to improve power system dynamic performance. A number of different quantities may be used as input to the power system stabilizer such as shaft speed, frequency, synchronous machine electrical power, and accelerating power.

The transfer function of a typical power system stabilizer is shown in Fig 9. The parameter values depend upon the nature of the input signal and the specific application of the stabilizer. Design ranges of typical parameters for power system stabilizers that have been applied in the United States are given in Table 3.

Regardless of the source for the power system stabilizer control signal, the control signal transducer should not introduce extraneous signals, such as ripple or random noise. Without the control signal connected to the transducer input, the output of the power system stabilizer following the signal conditioning and reset stages should be relatively free from noise generated by the transducer or signal conditioning stages. With the signal conditioning circuitry adjusted as in actual operation, the total influence of ripple or random noise should not exceed 10% of the dynamic range of the output of the power system stabilizer, unless otherwise specified. The control signal transducer should provide an output signal proportional to the deviation of the control signal with a time constant T_6 less than 0.04 seconds.

The fundamental function of the signal conditioning network of the power system stabilizer is to compensate for the phase lags of the system being controlled. Phase compensation is generally accomplished by the use of lead-lag functions providing phase lead over the frequency range of interest. With practical combinations of lead-lag networks, phase compensation can only be provided up to about 140° with two lead-lag functions. In many applications, the total amount of phase correction that can be usefully employed is limited by considerations of noise vulnerability. Most applications of power system stabilizers utilize two stages of phase compensation (see Fig 9); however, in some applications, three stages of compensation have been employed. In some applications employing high initial response excitation systems having low time constants, a single stage of compensation has been used.

For the best contribution to system damping, the gain K_S of the power system stabilizer should be maximized within the constraints imposed by the stability of the power system stabilizer control loop or any other synchronous machine modes of oscillation.

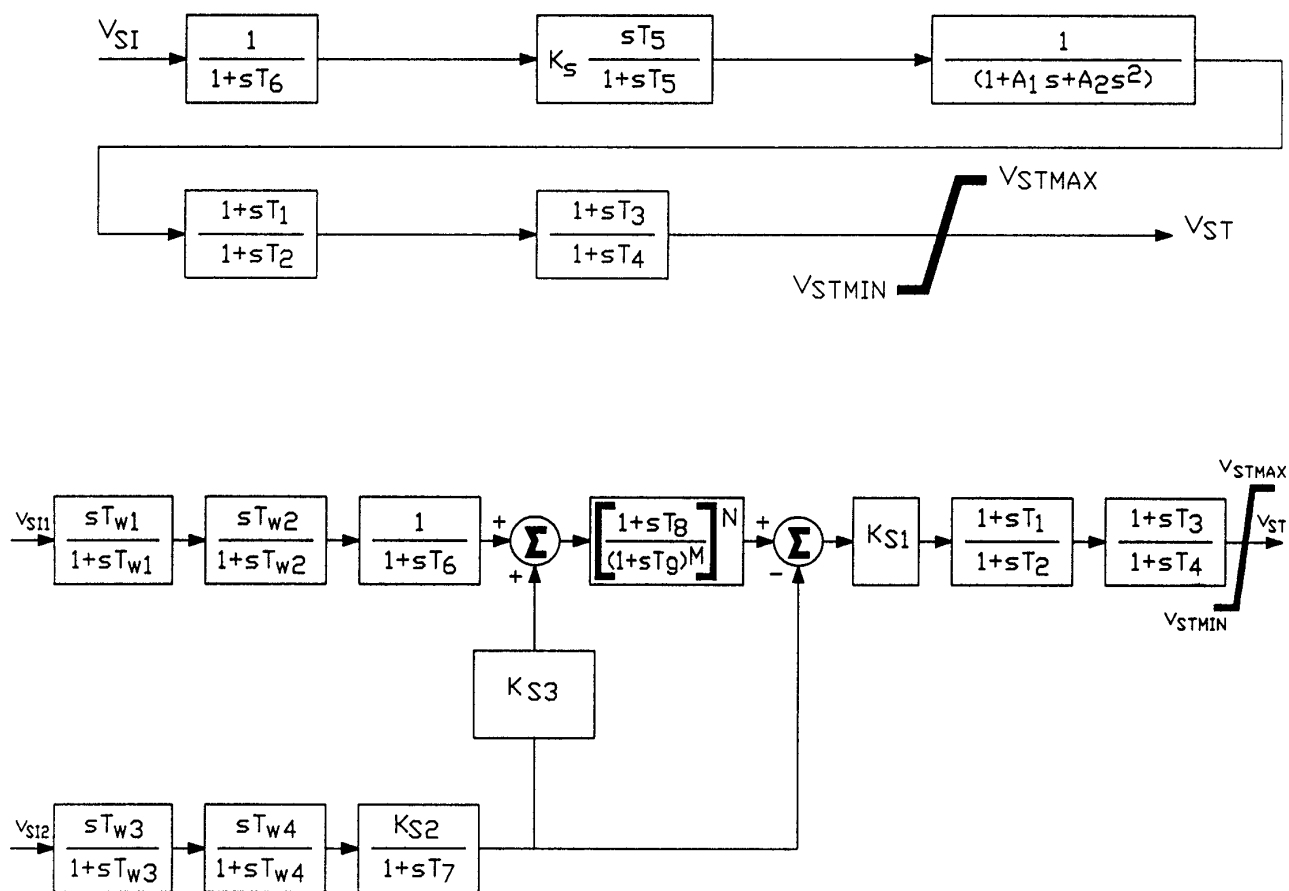

Figure 9—Block Diagrams Used to Represent Typical Power System Stabilizers

Table 3—Range of Typical Design Parameters for Power System Stabilizers with Frequency or Speed Input

Symbol	Typical Range	Parameters
T_6	0 to 0.04 s	Transducer time constant
T_5	0.5 s to 50 s	Washout time constant
T_1, T_3	0.1 s to 2 s	Lead time constants
T_2, T_4	0.01 s to 0.20 s	Lag time constants
K_S	0.10 pu to 50 pu	Stabilizer gain
V_{STMIN}, V_{STMAX}	± 0.02 pu to ± 0.10 pu	Stabilizer output signal limits

The speed change $\Delta\omega$ derived from any of the stabilizing inputs is a change with respect to a fixed frequency reference. The desired stabilizing signal has as its reference the base system frequency. This system frequency is not fixed but is

changing (normally slowly) all the time. This change causes the terminal voltage to vary. A washout function serves to minimize the effect of overall system speed changes on the machine terminal voltage.

Choice of washout time constant is not critical except that:

- 1) It should be long enough so that its phase shift does not interfere significantly with the signal conditioning network at the desired frequencies of stabilization.
- 2) It should be short enough that the terminal voltage will not be unduly affected by overall system speed variations, considering system islanding conditions, where applicable.

When synchronous machine electrical power is used as a stabilizing input, the washout function reduces voltage variations caused by turbine power changes. The power system stabilizer varies the voltage based on changes in electrical power caused by power system oscillations. When the turbine power changes, the stabilizer moves voltage with no benefit to power system damping. The washout function must be short enough to avoid voltage movement (typically 3 seconds to 5 seconds). The resulting damping is most effective for higher frequency interarea and interunit oscillations.

Most power system stabilizers incorporate limits on the output signal. Limiting may be accomplished by simple clipping of the stabilizer output signal as shown in Fig 9 (V_{STMIN} and V_{STMAX}) or it may be accomplished by control action through a terminal voltage limiter. In a few applications, limiting has been accomplished by disconnecting the stabilizer when terminal voltage deviation reaches preselected values.

The high-frequency filters are included as a means of representing shaft torsional filters (which are used with some power system stabilizers) as well as other high-frequency time constants within the power system stabilizer. They should not significantly detract from the primary control function of the power system stabilizer, although they may add an additional phase lag to the lower frequency modes.

Analytical studies and field test results of applications of power system stabilizers in North America are contained in References [3], [6], [7], [12], [14], and [15]. Suggested procedures for field testing and alignment of power system stabilizers are given in 7.3 (see also Reference [11]).

6. Large Signal Performance Testing

6.1 General

Standard procedures for large signal performance testing are not possible for all applications. Test procedures performed on small hydro units will not have the same impact on the power system that the same procedures might have on a large steam unit. The impact of testing is determined to a large extent by the nature of the power system surrounding the unit being tested. Large signal testing is not always justified. Model results can be used to predict the actual operation in situations where testing is impractical.

Large signal performance tests are used to demonstrate that the manufacturer has met the specified requirements of the customer (acceptance testing), to determine parameters for models used to predict large signal performance, and to ensure that the equipment is working correctly (periodic maintenance testing). When large signal tests are a part of acceptance test procedures, the criteria to be used in evaluating test results must be specified. The user and manufacturer must agree on which tests are to be performed, which tests are to be performed at the factory, which tests are to be performed at the installation site, and which tests can be replaced by results from model studies. Tests to determine model parameters or to validate model reliability are performed at the factory and in the field. Tests for model verification require close attention to specification of the conditions under which the tests are performed.

Tests described in this guide are generally for the positive response; i.e., an error signal simulating a decrease in terminal voltage is induced and the excitation control system response is to increase terminal voltage.

Testing to determine the negative response to an induced error signal simulating an increase in terminal voltage may also be required. Most systems have asymmetrical responses due to different positive and negative forcing actions. The test methods and performance criteria for negative responses are similar to those for positive responses.

6.2 Factory Testing

Most of the large signal tests were developed to permit acceptance testing to determine that the manufacturer had fulfilled the requirements of the customer's specifications. Ceiling voltage, ceiling current, voltage response, and nominal response are examples. The large signal performance criteria are used by the manufacturer to determine that the equipment meets the user's specifications. Factory testing is frequently performed only on prototypes of new equipment.

6.3 Field Testing

The procedures for any field test to determine large signal performance must be determined with consideration for the impact of the test upon the power system. Field tests fall primarily into four categories:

- 1) Testing immediately following the installation of new equipment or following the repair of faulty equipment
- 2) Testing to determine whether equipment meets the user's specifications
- 3) Testing to determine parameters for use in models or to validate model study results
- 4) Testing to diagnose existing or impending problems

Acceptance tests are performed to demonstrate that the manufacturer has met the user's specifications. They are performed in the field at the installation site and in the factory. Acceptance tests are usually performed on only one unit when several units are installed under one contract. They are closely associated with modeling tests. Some tests are impractical to perform under certain conditions, and model study results must be used to obtain the required information.

Modeling tests are performed to determine parameters for model studies and to validate results from model studies. Whenever large signal testing is performed on machines connected to the power system, it is beneficial to record as much information as possible about the operating conditions of the surrounding power system. This "snapshot" of power system quantities can provide the basis for the load flow program solution upon which the transient analysis is based.

Some large signal performance tests must be performed under normal full load conditions. When possible, it is preferred that tests be performed with the synchronous machine open-circuited, thereby eliminating any impact upon the power system.

Testing associated with large signal modeling has different requirements depending on the type of excitation system being tested. Since most models are used for stability studies, it is important that testing for modeling purposes be performed as near to fault conditions as is possible. Testing for acceptance and modeling purposes should be closely coordinated. Field testing to validate models increases the reliability of model results. Model results can be used where field testing is not practical to predict the actual operation.

Field tests to evaluate the excitation system performance and to check the operation of the excitation system functions, including limiter and protection devices, should be conducted at intervals of 5 years or even more frequently. Coordination of excitation system limiter and protection functions with protective relaying settings should be verified during these tests.

6.3.1 Time Responses

Ceiling voltage, voltage response time, voltage response, and nominal response may all be determined from an excitation system voltage time response. It is beneficial to obtain some form of record of excitation control system variables for a short duration change in synchronous machine regulator error voltage corresponding to a specified drop in terminal voltage. Transducers are available to convert terminal voltage and synchronous machine field voltage to low voltage isolated dc signals that are compatible with recorders. Recorders with four or more channels can be used to record transducer signals representing the synchronous machine error voltage, synchronous machine field current, and synchronous machine field and terminal voltages.

A typical time response is obtained with the exciter voltage initially at rated field voltage of the synchronous machine to which the exciter is applied. Some means is used to cause the synchronous machine regulator error voltage to change for a short duration corresponding to a specified decrease in terminal voltage. The duration of the change must be short enough that excitation control system quantities remain within acceptable ranges. For high initial response excitation systems, the error signal needs to be applied for only a very short time due to the speed of these systems. All excitation control system stabilizing circuits (other than the power system stabilizer circuits) or other feedback control circuits that are part of the synchronous machine regulator should be adjusted as in actual operation, where possible and practical. The power system stabilizer should *not* be in operation. Figure 10 shows the results of a field test made on one high initial response excitation system to determine ceiling voltage and excitation system voltage response time. It is representative of the type of records used but is not representative of all high initial response systems.

These time response records can usually be obtained near rated operation without endangering the operation of the synchronous machine or the power system. It is essential that the duration of the change in synchronous machine regulator error voltage be limited to a short time. The time should be short enough that the change in excitation system variables is acceptable. Time responses are frequently obtained by one of two methods—either a signal is injected at the summing junction where the error signal is produced or the terminal voltage signal into the sensing circuit is forced to reflect the desired change in terminal voltage. The method of injecting a signal into the summing junction is sometimes easier to implement; but it does have one drawback. The injection at the summing junction bypasses the transducer time constant which may be a major time constant in a fast system. Analytical means may be required to combine the effects of the transducer filter with the time response test results.

6.3.2 Limiter and Protection Concerns

Large signal testing with the synchronous machine connected to the power system requires consideration of limiter and protection settings. Large signal tests may be used to check the operation and setting of these devices.

6.3.3 Ceiling Voltage

The measurement of ceiling voltage with the synchronous machine open-circuited will prove straightforward, except in the case of an excitation system that utilizes both synchronous machine voltage and current for the excitation system source. Brushless excitation systems that do not use slip rings may be more difficult to test unless a system employing special voltage test probes is implemented.

The measurement of a ceiling voltage at any synchronous machine load is only possible when the excitation system voltage can reach the ceiling value and return to the initial value in a duration sufficiently short that the other excitation control system quantities remain within acceptable limits. When ceiling voltage cannot be reached due to operational constraints, data may be extracted from time responses for conditions that produce conditions as near to ceiling as possible. These data can generally be used to verify model parameters and the model may be used to determine the value of the ceiling voltage.

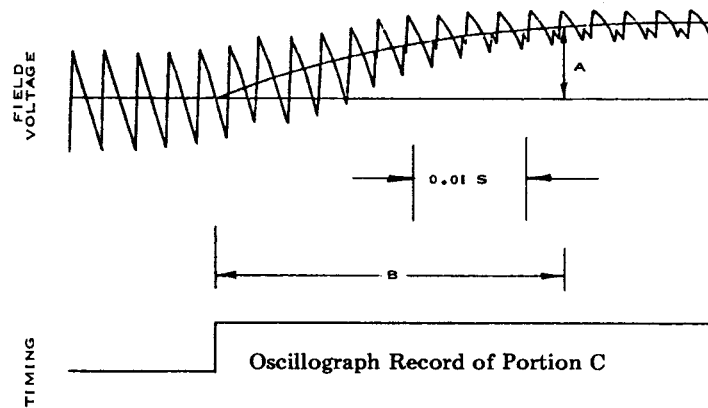
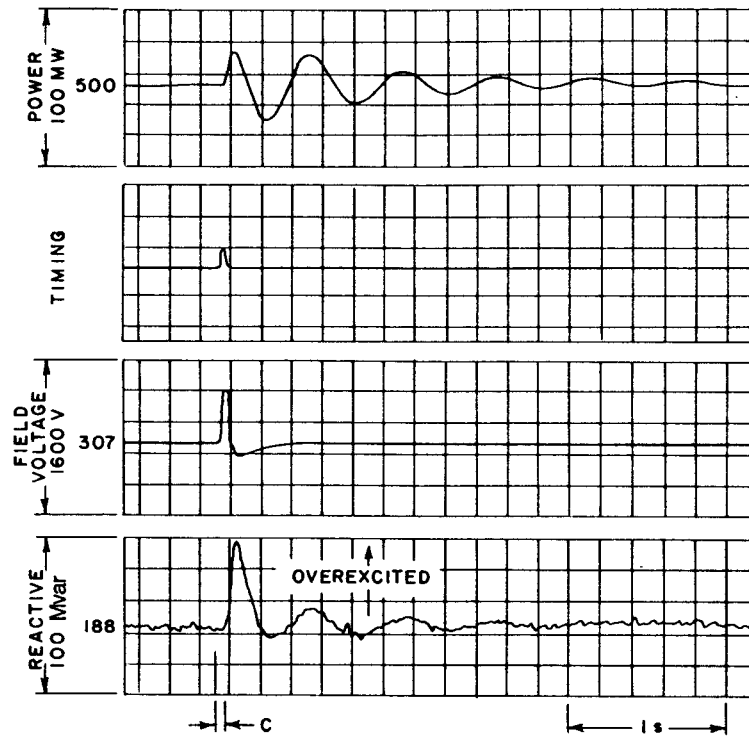

LEGEND

- A = Ninety-five percent of the difference between ceiling voltage and rated field voltage.
- B = Excitation system voltage response time.

Figure 10—Large Signal (10% Voltage Error) Field Test of a High Initial Response Excitation System

The definition of ceiling voltage is used to evaluate the forcing capability of the excitation system toward ceiling current. Since instantaneous current limiter circuits may be used in some exciter designs, the ceiling voltage must be determined before such limiter action occurs.

6.3.4 Voltage Response Time

Excitation system voltage response time in the positive direction can be determined from the excitation system voltage time response (see 6.3.1). The time measurement begins at the time the disturbance is initiated and ends when the time response reaches 95% of the difference between ceiling voltage and rated field voltage.

Where the synchronous machine field voltage record of the time response does not attain ceiling voltage, analytical means may be used to determine the approximate voltage response time. The excitation system voltage time response should come as close to ceiling voltage as possible or practical for the analytic means to be most accurate.

6.3.5 Nominal Response

The nominal response is based upon a linear approximation of the excitation system voltage time response (see 6.3.1) for the first 0.5 second. A straight line is determined such that the area under the line and the area under the time response are the same over the 0.5 second interval of interest. In Fig 2, the line ac is chosen to make the shaded areas equal. The excitation system voltage at 0.5 second on this line (point c in Fig 2) is used to calculate the nominal response. The increase in excitation system voltage (ce-ao in Fig 2) is divided by the rated field voltage (ao in Fig 2) and by the time interval (oe=0.5 second in Fig 2) to obtain the nominal response in per unit rated field voltage per second.

The determination of nominal response requires that the excitation system voltage be initially equal to the rated field voltage of the synchronous machine (see IEEE Std 421.1-1986 (ANSI) [2]). During field tests, it may not be possible to operate with this initial field voltage due to power system voltage and reactive power restrictions. For large exciters, even factory loading tests may prove impractical due to the large power magnitudes that are involved.

6.3.6 Ceiling Current

The field testing of ceiling current will seldom prove practical because of the excessively high current that is required. The impact on the power system from this disturbance is seldom acceptable.

When the field current is limited to some predetermined value by the use of an instantaneous current limiter, tests may be performed to determine that the limiter is functioning properly. It may be necessary to test the limiter operation at a current value considerably below the desired value in order to limit the impact on the power system. Analytical means may be used to determine the desired limiter settings from the test results at the lower current value.

6.4 Fault Testing

Fault tests where three-phase, line-to-line, or line-to-ground faults are used for testing the operation of transmission line or synchronous machine protection also provide a good opportunity for evaluating the performance of the excitation control system under fault conditions. Records from these tests provide a method for obtaining values for the large signal performance criteria under conditions more closely approximating typical fault conditions.

6.5 Power System Disturbances

For verification of model parameters, records are required during system disturbances. When disturbance monitoring equipment is being installed, consideration must be given to excitation control system quantities of interest. Terminal voltage and field voltage of the synchronous machine should be monitored where possible. Consideration should be given to monitoring the transduced signal rather than the ac waveform. If the excitation system equipment provides transduced signals for field current and synchronous machine regulator output or error signals, it may be beneficial to

monitor them. Where equipment is available, monitoring of the excitation system stabilizer and maximum and minimum excitation limiter operation should be considered. For maximum benefit, the recording equipment bandwidth must be appropriate for the signal being monitored.

7. Small Signal Performance Testing

7.1 Excitation Control System Components

Transfer functions describing the dynamic performance of excitation control system components can be derived from each component's small signal performance data. These data may be obtained by time domain transient response testing or frequency response testing. One of the important uses of the transfer functions obtained from these tests is in the development of models for analog and digital computer simulation of power system dynamics.

Transient response testing consists of applying a transient (step or ramp) into the input of the element or elements under test and recording the output response. For example, rise time, overshoot, and settling time can be obtained directly from the transient response test. Another direct use of the transient response test is in periodic verification of performance. This can be done by comparing the result of the transient test performed periodically with the corresponding tests performed at the time of unit commissioning. This procedure is sometimes called "signature analysis." An example of transient response tests in signature analysis is shown in 7.3.

A disadvantage of transient response testing is that, if the transfer function of the element under test is to be determined, the data must be reduced to a form which will yield this information. Methods of accomplishing this include performing an inverse Fourier transform on the transient response and the test signal, usually with the aid of a digital computer; performing a graphical analysis on the data approximating the transient response as a series of impulse responses; and iterative simulation on an analog computer. All of these methods can be lengthy and can involve extensive iterative calculation. Also, accuracy may be questionable if the output of the element being tested contains appreciable noise.

If the system being tested contains a dominant real pole or a dominant pair of complex poles (near the $j\omega$ axis in the S-plane), a transient response test is often useful in measuring the position of these poles on the S-plane. For example, if a damped sinusoidal oscillation dominates the response, a measurement of the frequency of the response (f_o in hertz) and the time constant (t_o in seconds) that its envelope decays is enough information to locate these complex poles on the S-plane. The position $\sigma \pm j\omega$ will be at $\sigma = -1/t_o$ (sec^{-1}) and $\omega = 2\pi f_o$ (radians per second).

Frequency response testing consists of applying a known driving signal to the input of the element under test and measuring the output with respect to the input. There are several methods that are used to measure frequency response, including methods that apply either sinusoidal or noise signals. Frequency response testing has the advantage that the transfer function of the element under test is often immediately evident. For this reason, the frequency response method is recommended for determining the transfer functions of excitation system components. Frequency response can be measured using commercially available conventional frequency response analyzers or modern spectrum analyzers. The spectrum analyzers directly produce the gain and phase plots shown in Fig 5 (see also Reference [6]). The spectrum analyzers use averaging techniques to reduce noise and require a relatively small driving signal.

The following precautions should be observed in frequency response testing:

- 1) Care should be taken to ensure that the driving signal does not cause saturation of the elements under test. A signal magnitude causing output variations that are linear about the quiescent operating point is recommended.
- 2) The range of test frequencies should be broad enough to fully describe the dynamic characteristics of the element(s) under test. The frequency resolution should accurately describe abrupt changes in the response curve, particularly in the vicinity of resonant peaks. Generally, the commercially available spectrum

analyzers have enough resolution to cover the complete range of interest (0 to 60 Hz) in a single measurement.

- 3) In measuring the response of rotating exciters in the factory, it may be necessary to insert a power amplifier between the driving signal source and the exciter field. The transfer function of the power amplifier should be recorded.
- 4) In measuring the response of power components, such as power amplifiers and exciters, it may be desirable to insert isolation transducers between the output of the power component and the test instrumentation. Also, it may be necessary to filter the output of the power component. The transfer function of the transducers and filters should be recorded.
- 5) The test should be performed in the expected operating range of the element under test. For example, the frequency response of a rotating amplifier varies with loading. When measuring the response of individual elements of an excitation system, care should be taken with respect to possible variation of expected overall response when the elements are connected together due to loading and interaction effects. This applies primarily to excitation systems employing passive circuit elements and rotating or magnetic amplifiers. In excitation systems employing solid-state control elements, those elements are normally free of interaction and loading effects. Should these effects be present, the overall frequency response of the group of elements interconnected in their normal configuration should be measured in addition to the response of the individual elements. Typical frequency response characteristics and corresponding transfer functions of elements commonly encountered in excitation systems are shown in Appendix B.

7.2 Field Testing

The transient and frequency response characteristics can fully describe the small signal dynamic performance of the excitation control system. These characteristics can be determined by field testing as described in this section.

With the exception of those alternator-rectifier excitation systems in which the exciter terminals are not available and compound-rectifier excitation systems, most of the excitation system component tests described in 7.1 could be performed in the field or factory prior to testing of the excitation control system.

Most excitation control systems include some form of internal stabilization such as rate feedback. The function of this internal compensation is to ensure stability of the excitation control system offline and to provide a means of adjusting the transient response of the system. During startup of a new synchronous machine installation, it is normal procedure to check the transient response of the unit offline in order to adjust the settings of the excitation system stabilizers. This is best done by inserting a small step change into either the reference or sensing circuitry of the synchronous machine regulator and recording machine terminal voltage response. It is recommended that an ac to dc voltage transducer with adjustable null balance providing zero suppression be used to record only the deviation in terminal voltage.

For an excitation system having small time constants, an acceptable transient response might be considered as one having no more than two overshoots with a maximum overshoot of 5% to 15%. In some applications, it may be desirable to increase the bandwidth of the excitation system for faster response. In such applications, higher overshoot can be expected.

Field testing to obtain the frequency response characteristics of excitation control systems yields data that is useful for system identification and for verification of mathematical models for use in power system stability studies. Data obtained from frequency response testing is also useful in determining suitable settings for power system stabilizers as described in 7.3. In measuring the frequency response of an excitation control system, a small signal, limited to cause less than 2% excursions in terminal voltage, is inserted into the regulator reference and sensing summing junction. The excitation control system closed-loop frequency response should be measured with a minimum bandwidth from 0.1 Hz to 3 Hz. It is frequently desirable to record deviations in the variables of interest during these tests. Phase and amplitude responses can be obtained directly using a commercially available frequency response analyzer or spectrum analyzer. To obtain a 0.25% to 2% variation in terminal voltage will require a progressively larger driving signal. Likewise, in measuring frequency response using the spectrum analyzers, the power level and bandwidth of the noise driving signal must be carefully selected to provide adequate power for measurements without permitting excessive

transients. Care should be taken to ensure that the excitation control system quantities do not encounter limits. They should be monitored during the test. Preferably, frequency response measurements should be made with the unit offline and with the unit online and operating near full load with external system conditions as in normal operation.

CAUTION — If the conventional method of frequency response measurement is used in which a discrete frequency signal is injected into the excitation system, the following precautions should be taken:

- (1) In frequency response testing of a unit online, caution must be used when testing near the resonant frequency of the unit.
- (2) To fully measure the bandwidth of some excitation control systems, it is necessary to test at frequencies higher than 3 Hz. Extreme care should be taken not to excite the torsional natural frequencies of the unit shaft which could result in severe mechanical damage. The unit manufacturer should be consulted prior to testing at frequencies above 3 Hz.

When the digital signal analysis techniques using random noise excitation are employed, the above risks are considerably reduced.

As previously described in 4.3, opened-loop frequency response characteristics are useful in determining the relative stability of a feedback control system. It is usually not practical to determine the opened-loop frequency response characteristics of excitation control systems directly by field testing. They can, however, be derived by superposition of the synchronous machine regulator characteristics with those of the combined exciter and synchronous machine.

Field tests to evaluate the excitation control system performance and to check the operation of the excitation system functions, including limiter and protection devices, should be conducted at intervals of 5 years or even more frequently.

7.3 Field Testing with Power System Stabilizers

Frequency response testing is a convenient means for experimentally checking parameter ranges, determining parameter settings, and verifying power system stabilizer performance. The stabilizer control signal transducer calibration must be determined. The transducer should be calibrated in volts/pu where 1 pu is based upon rated speed, frequency, or MVA depending on the stabilizer input signal. Depending on design and configuration, transducer response time may, in some cases, be determined experimentally by frequency response techniques similar to those described earlier for testing of the components of the excitation system.

The settings of the time constants of the phase compensating lead-lag functions of the stabilizer can be determined by several techniques once the frequency response of the excitation control system has been measured as described in 7.2 of this guide. Regardless of the technique used to determine these settings, the ultimate goal is to compensate for the phase lags in the excitation control system so that the stabilizer, through the excitation system, adds a component of torque that is in phase with speed deviation (see Reference [5]). The stabilizer should ideally increase the damping component or torque without affecting the synchronizing component. For the lower frequencies of oscillation associated with interarea modes, adjusting the terminal voltage variation to be in phase with the frequency deviation will fulfill the same requirement. Desired alignment of the phase compensating network may be verified by frequency response measurements. Typical frequency responses of lead-lag functions are presented in Figs B.4 and B.5 of Appendix B.

The stabilizer gain should be maximized within the constraints imposed by the recommended stability margin of the control loop. The maximum permissible gain depends upon many factors and can be determined by test.

Figure 11 shows typical frequency response field test data of an excitation control system with and without a power system stabilizer. Note that the frequency response characteristics $\Delta V_T/\Delta V_R$ and $\Delta V_T/\Delta V_S$ shown in Fig 11 are convenient to measure and yield adequate information for determining and verifying suitable settings of the stabilizer to improve damping of lower (< 0.3 Hz) frequency interarea oscillations. In determining and verifying suitable

stabilizer settings to improve damping of higher frequency (1 Hz to 2 Hz) local mode oscillations, the transfer function for which compensation should be provided is $\Delta T/\Delta V_R$, which is the change in torque (or power) with respect to change in reference voltage.

If adjustments have been adequate, the phase lag will be nearly zero over the useful range as shown in Fig 11. The gain curve will also be reasonably flat over this range. Readjustments of time constants may be made and the check rerun, if necessary. Note that, with the gain curve nearly flat, unlike in the initial frequency response run, it will not be necessary to increase the input signal as the frequency is increased. However, care will again be necessary to ensure that signal limiting does not occur at the higher frequencies.

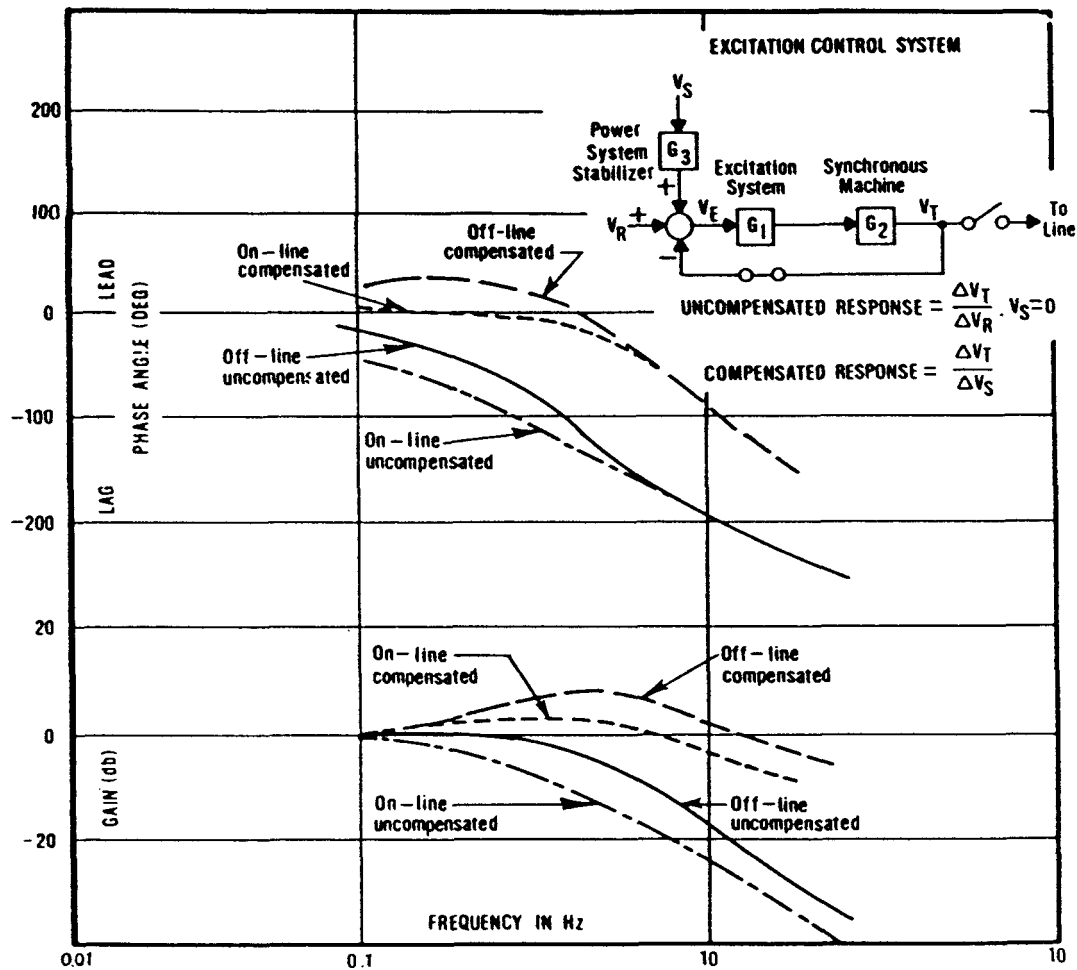

Figure 11—Field Test Data-Frequency Response of a Typical Excitation Control System (with DC Commutator Exciter) with and without a Power System Stabilizer



Figure 12—Field Test Data—Power System Stabilizer Signature Tests

Verification of power system stabilizer dynamic performance can also be made by transient response testing. The field test data in Fig 12 show the transient response of an excitation control system equipped with a power system stabilizer to a step change in regulator input signal.

A recording of transient response such as that shown in Fig 12 is also very useful in signature analysis; it provides a means of periodically verifying that a power system stabilizer is functioning properly. Transient response characteristics (the “signature”) of an excitation control system with and without the power system stabilizer can be quickly obtained periodically and compared to the data recorded during the initial operation of the particular equipment.

Annex A Basis Underlying the Concept of Nominal Response

(Informative)

In order to appreciate the usefulness of the excitation system nominal response as a measure of the ability of the excitation system to affect transient stability, consider a synchronous generator with only a single rotor circuit in each axis and no saliency. The phasor diagram, which must be satisfied under both transient and steady-state conditions, is shown in Fig A.1.

Since the flux linking the rotor circuits and the stator cannot change instantly, the electrical torque can be conveniently expressed as:

$$T_e = \frac{E' E_s}{X' + X_E} \sin \beta$$

Under the assumption of “constant” flux linkages (sometimes referred to as “classical”), this torque is not a function of time, and a greatly simplified analysis is possible.

However, currents can change instantly, and components are induced in the rotor circuits to balance those in the stator circuit in order to satisfy the constant flux linkage theorem (see Excitation System Dynamic Characteristics, IEEE Committee Report, *IEEE Transactions on Power Apparatus and Systems*, vol. PAS-92, no. 1, Jan./Feb. 1973, pp. 64–75). The flux linkages do change slowly and in the direct axis are described by the relationship:

$$\frac{d}{dt} E'_q = \frac{E_{FD} - E_I}{T'_{d0}}$$

$$E'_q = \frac{1}{T'_{d0}} \left[\int E_{FD} dt - \int E_I dt \right]$$

The term including E_I is determined from generator and power system characteristics. The effect of the excitation system is determined by the E_{FD} term.

Following a severe power system disturbance, the generator rotor angle undergoes large excursions at a frequency determined by the rotational inertia and the electrical stiffness of the power system. The maximum angular swing will normally peak between 0.4 and 0.75 second after the disturbance initiation, and the excitation system must act within this time period to affect transient stability considerations. Accordingly, 0.5 second was chosen for the definition time period of the nominal response. The nominal response is the slope of a straight line (in per unit per second) constructed to encompass the same area as the actual exciter voltage curve over the 0.5 second period. It may be expressed as:

$$\int_0^{0.5} E_{FD} dt = \int_0^{0.5} (E_0 + Kt) dt$$

The area under the actual voltage-time response curve equals the area under the constructed straight line.

This reduces to:

$$\text{Nominal response} = \frac{K}{E_0} = \frac{8}{E_0} \int_0^{0.5} E_{FD} dt - 4$$

A.1 Nomenclature for Appendix A

(See also Excitation System Dynamic Characteristics, IEEE Committee Report, *IEEE Transactions on Power Apparatus and Systems*, vol. PAS-92, no. 1, Jan./Feb. 1973, pp. 64–75.)

- X' = Transient reactance of the machine.
 X_s = Synchronous reactance of the machine.

NOTE — The assumption is made that both the transient and synchronous reactances are constant regardless of the angular position of the rotor with respect to the armature reaction, $X' = X_D' = X_Q'$ and $X_s = X_D = X_Q$. This assumption is made to facilitate analysis of relatively simple cases of transient stability.

- E' = Equivalent voltage back of transient reactance, corresponding to the more slowly decaying component of flux linkages of the rotor.
 E'_q = Component of E' due to the more slowly decaying component of flux linkages in the direct axis. These flux linkages generate a voltage in the quadrature axis lagging the direct axis 90° .
 E'_d = Component of E' due to the more slowly decaying component of flux linkages in the quadrature axis.
 X_e = External reactance between the machine terminals and the infinite bus.
 E_s = Voltage of the infinite bus.
 E_f = Voltage corresponding to the generator field current (saturation neglected).
 E_0 = Initial value of generator field voltage; assumed to be generator rated load field voltage unless otherwise specified.
 I_t = Armature current.
 T_e = Electrical torque.
 T'_{d0} = Direct axis transient open-circuit time constant.
 K = Slope (volts per second) of the straight line constructed to determine nominal response.
 δ = Electrical angular displacement between the rotors or the voltages in quadrature with the rotors.
 β = Electrical angular displacement between the infinite bus voltage and the voltage behind transient reactance.

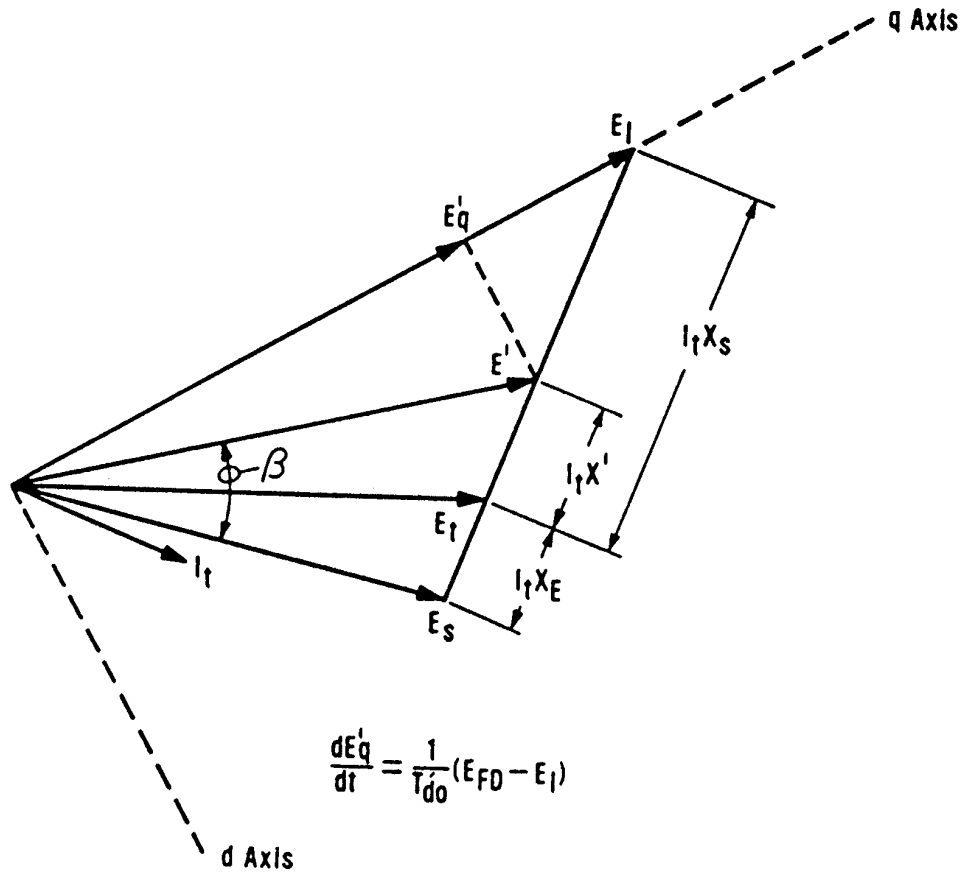

Figure A.1—Phasor Diagram of a Simplified Synchronous Generator Against an Infinite Bus

Annex B Frequency Response Characteristics of Typical Excitation Control

System Elements

(Informative)

Appendix B consists of a series of figures that illustrate the frequency responses for several typical excitation control system elements.

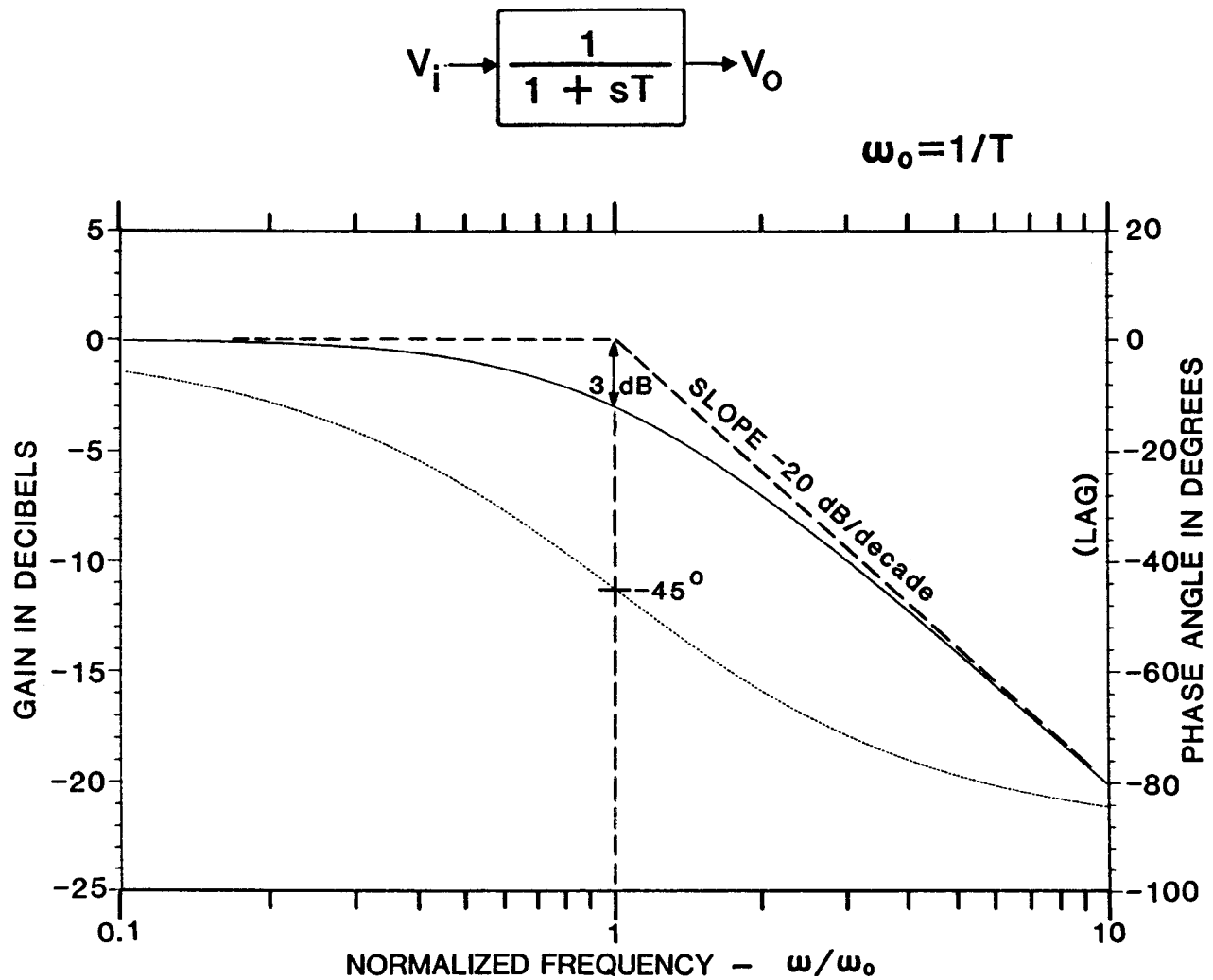

Figure B.1—First Order System

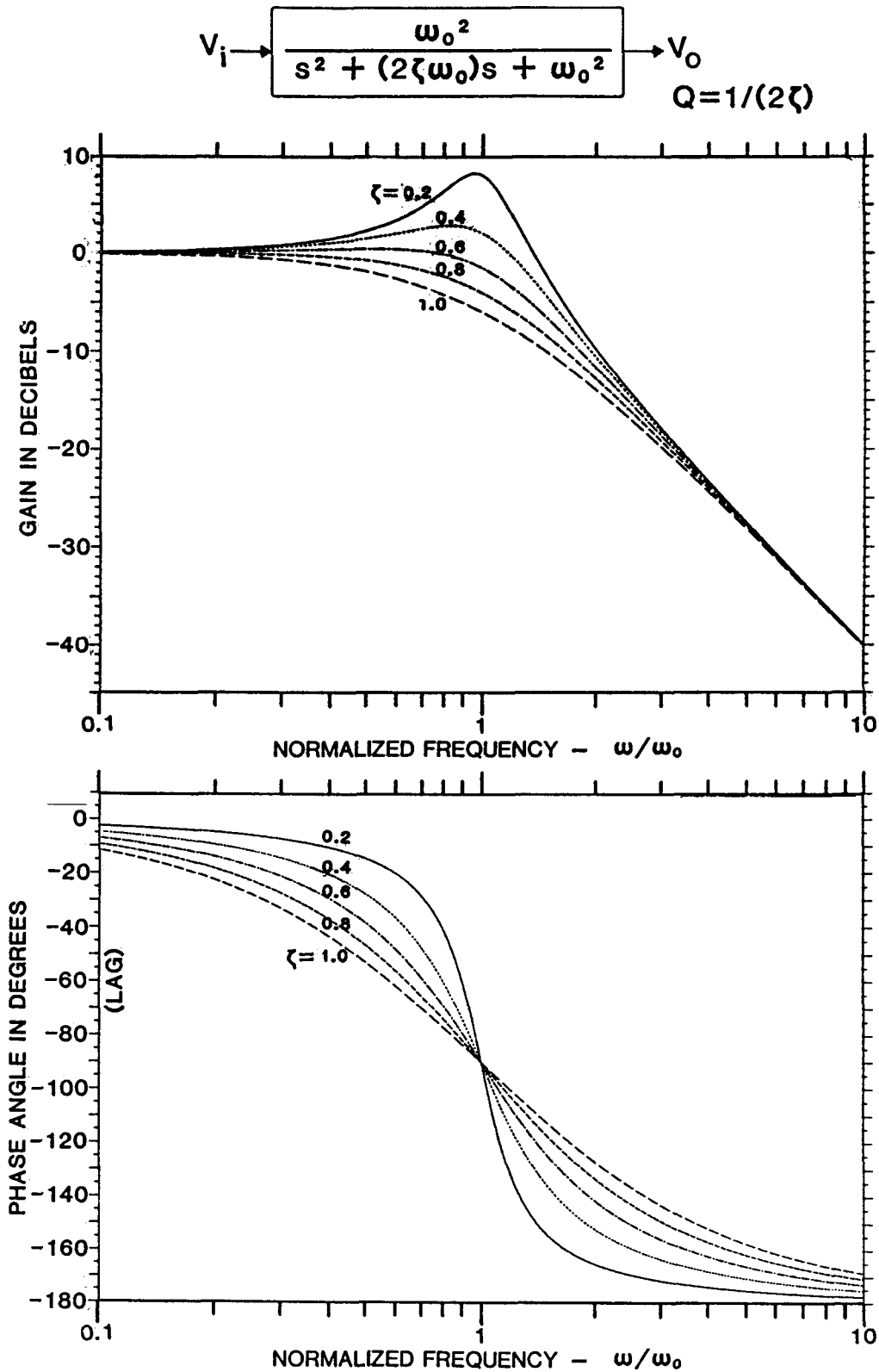

Figure B.2—Second Order System

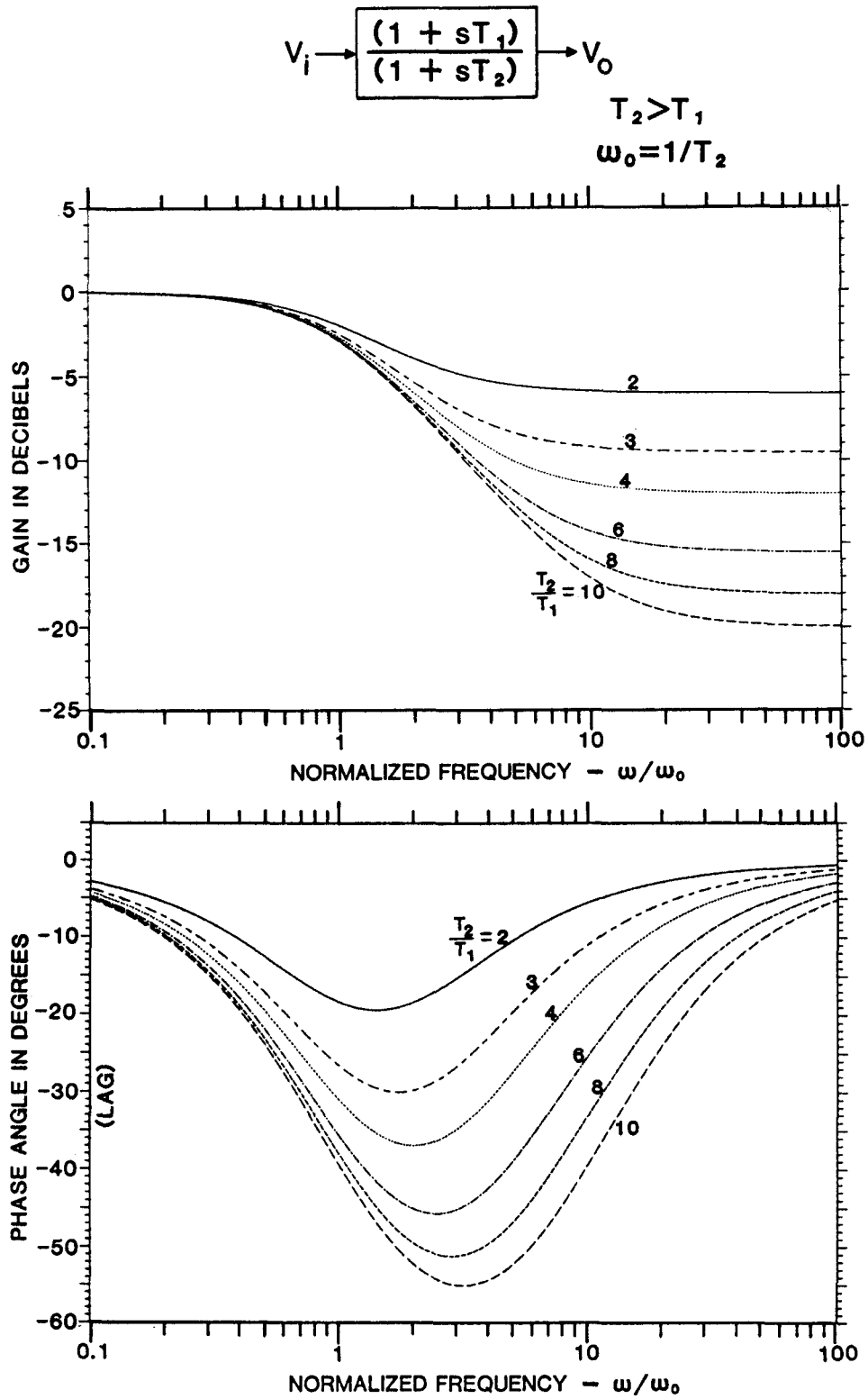

Figure B.3—Lag-Lead Function

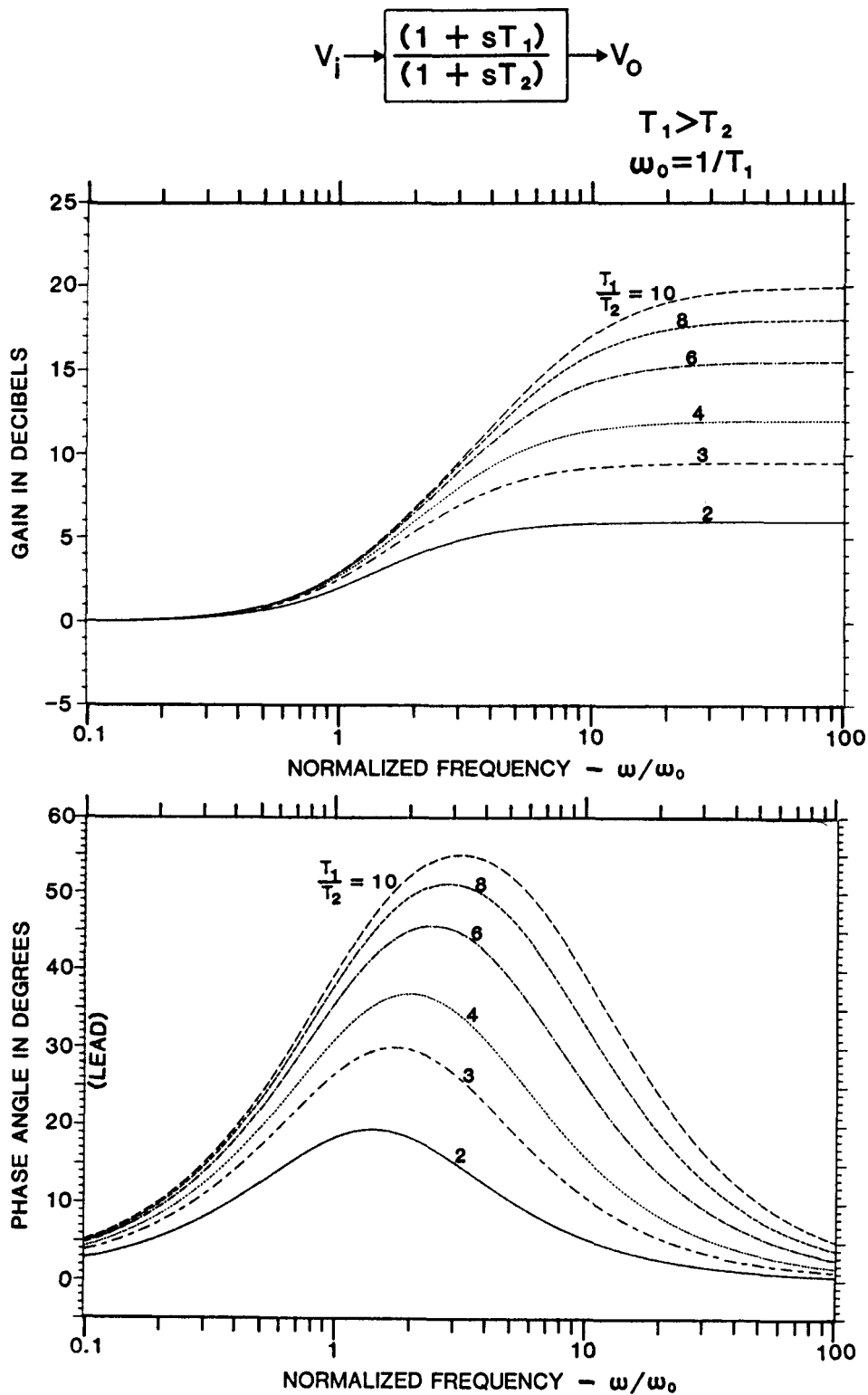

Figure B.4—Lead-Lag Function

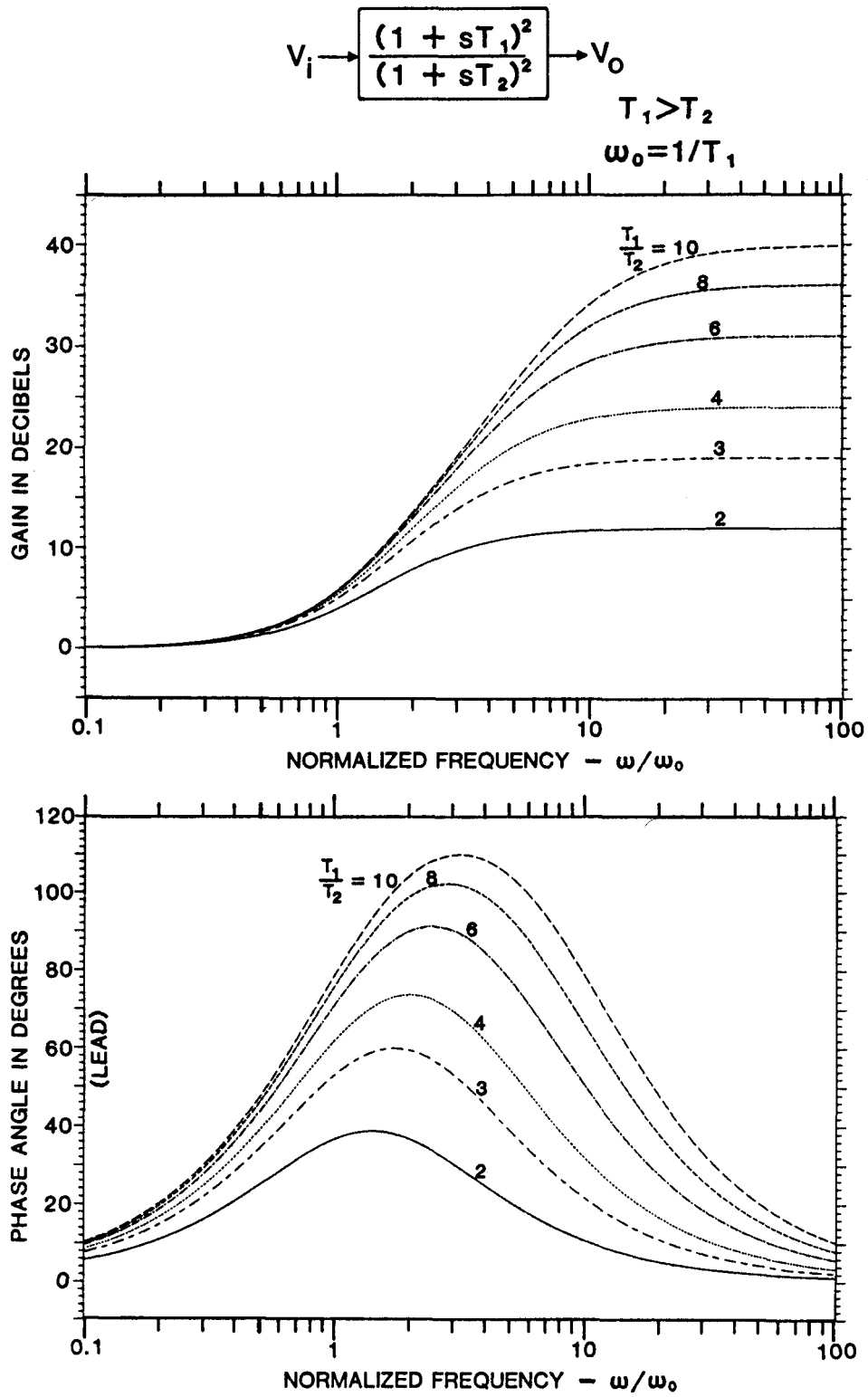

Figure B.5—Twin Lead-Lag Function

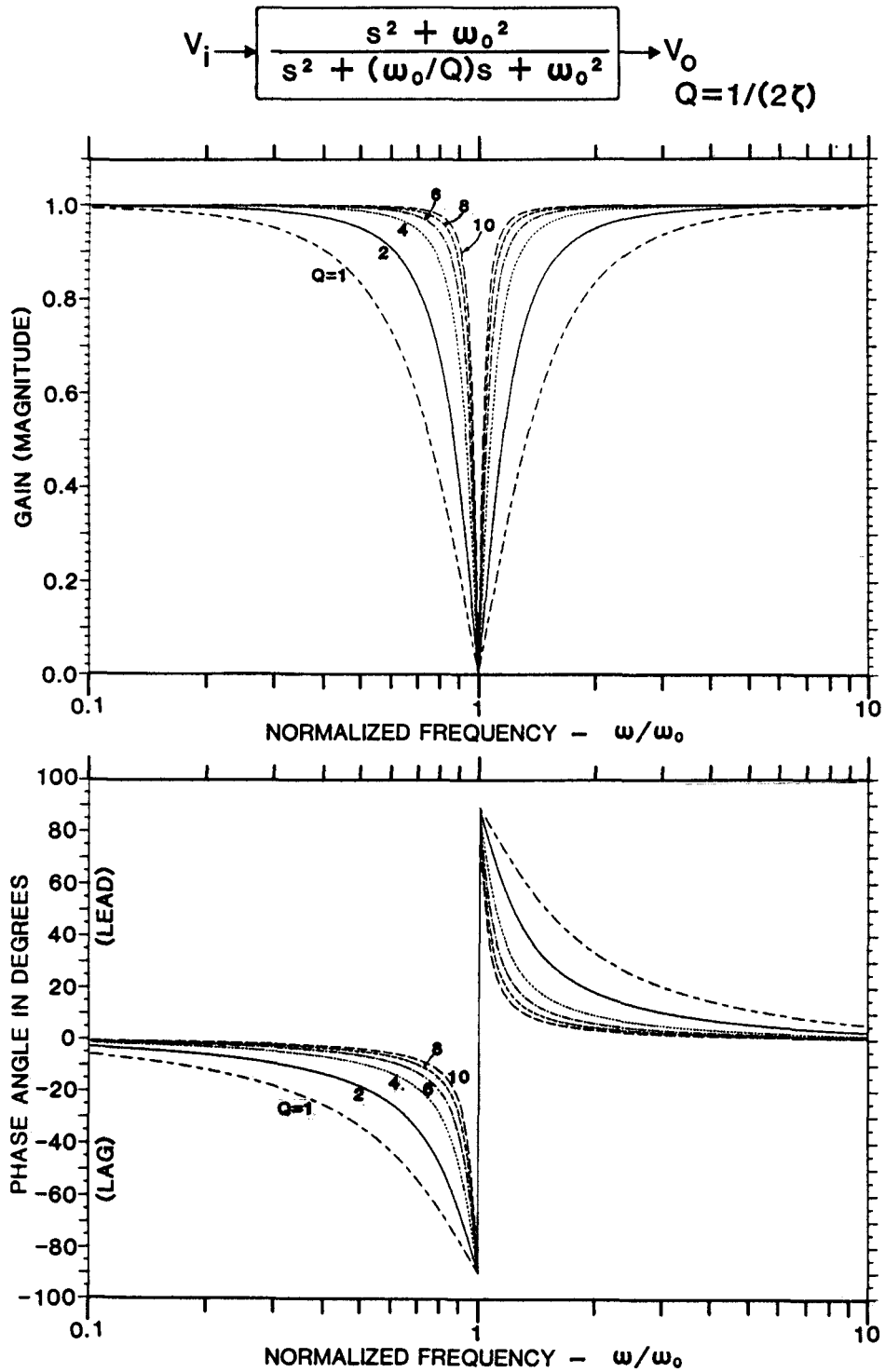

Figure B.6—Biquadratic Notch Filter Function