

IEEE Std 837™-2002
(Revision of
IEEE Std 837-1989)

IEEE Standards

837™

**IEEE Standard for Qualifying
Permanent Connections Used
in Substation Grounding**

IEEE Power Engineering Society

Sponsored by the
Substations Committee



Published by
The Institute of Electrical and Electronics Engineers, Inc.
3 Park Avenue, New York, NY 10016-5997, USA

9 May 2003

Print: SH95125
PDF: SS95125

IEEE Standard for Qualifying Permanent Connections Used in Substation Grounding

Sponsor

Substations Committee
of the
IEEE Power Engineering Society

Approved 11 November 2002

IEEE-SA Standards Board

Abstract: Direction and methods for qualifying permanent connections used for substation grounding are provided in this standard. This standard particularly addresses the connection used within the grid system, the connection used to join ground leads to the grid system, and the connection used to join the ground leads to equipment and structures.

Keywords: conductor, conductor combination, connection, connection thermal capacity, control conductor, current loop cycle, equalizer, grid system, permanent connection

The Institute of Electrical and Electronics Engineers, Inc.
3 Park Avenue, New York, NY 10016-5997, USA

Copyright © 2003 by the Institute of Electrical and Electronics Engineers, Inc.
All rights reserved. Published 9 May 2003. Printed in the United States of America.

IEEE is a registered trademark in the U.S. Patent & Trademark Office, owned by the Institute of Electrical and Electronics Engineers, Incorporated.

Print: ISBN 0-7381-3664-6 SH95125
PDF: ISBN 0-7381-3665-4 SS95125

No part of this publication may be reproduced in any form, in an electronic retrieval system or otherwise, without the prior written permission of the publisher.

IEEE Standards documents are developed within the IEEE Societies and the Standards Coordinating Committees of the IEEE Standards Association (IEEE-SA) Standards Board. The IEEE develops its standards through a consensus development process, approved by the American National Standards Institute, which brings together volunteers representing varied viewpoints and interests to achieve the final product. Volunteers are not necessarily members of the Institute and serve without compensation. While the IEEE administers the process and establishes rules to promote fairness in the consensus development process, the IEEE does not independently evaluate, test, or verify the accuracy of any of the information contained in its standards.

Use of an IEEE Standard is wholly voluntary. The IEEE disclaims liability for any personal injury, property or other damage, of any nature whatsoever, whether special, indirect, consequential, or compensatory, directly or indirectly resulting from the publication, use of, or reliance upon this, or any other IEEE Standard document.

The IEEE does not warrant or represent the accuracy or content of the material contained herein, and expressly disclaims any express or implied warranty, including any implied warranty of merchantability or fitness for a specific purpose, or that the use of the material contained herein is free from patent infringement. IEEE Standards documents are supplied “**AS IS.**”

The existence of an IEEE Standard does not imply that there are no other ways to produce, test, measure, purchase, market, or provide other goods and services related to the scope of the IEEE Standard. Furthermore, the viewpoint expressed at the time a standard is approved and issued is subject to change brought about through developments in the state of the art and comments received from users of the standard. Every IEEE Standard is subjected to review at least every five years for revision or reaffirmation. When a document is more than five years old and has not been reaffirmed, it is reasonable to conclude that its contents, although still of some value, do not wholly reflect the present state of the art. Users are cautioned to check to determine that they have the latest edition of any IEEE Standard.

In publishing and making this document available, the IEEE is not suggesting or rendering professional or other services for, or on behalf of, any person or entity. Nor is the IEEE undertaking to perform any duty owed by any other person or entity to another. Any person utilizing this, and any other IEEE Standards document, should rely upon the advice of a competent professional in determining the exercise of reasonable care in any given circumstances.

Interpretations: Occasionally questions may arise regarding the meaning of portions of standards as they relate to specific applications. When the need for interpretations is brought to the attention of IEEE, the Institute will initiate action to prepare appropriate responses. Since IEEE Standards represent a consensus of concerned interests, it is important to ensure that any interpretation has also received the concurrence of a balance of interests. For this reason, IEEE and the members of its societies and Standards Coordinating Committees are not able to provide an instant response to interpretation requests except in those cases where the matter has previously received formal consideration.

Comments for revision of IEEE Standards are welcome from any interested party, regardless of membership affiliation with IEEE. Suggestions for changes in documents should be in the form of a proposed change of text, together with appropriate supporting comments. Comments on standards and requests for interpretations should be addressed to:

Secretary, IEEE-SA Standards Board
445 Hoes Lane
P.O. Box 1331
Piscataway, NJ 08855-1331
USA

Note: Attention is called to the possibility that implementation of this standard may require use of subject matter covered by patent rights. By publication of this standard, no position is taken with respect to the existence or validity of any patent rights in connection therewith. The IEEE shall not be responsible for identifying patents for which a license may be required by an IEEE standard or for conducting inquiries into the legal validity or scope of those patents that are brought to its attention.

Authorization to photocopy portions of any individual standard for internal or personal use is granted by the Institute of Electrical and Electronics Engineers, Inc., provided that the appropriate fee is paid to Copyright Clearance Center. To arrange for payment of licensing fee, please contact Copyright Clearance Center, Customer Service, 222 Rosewood Drive, Danvers, MA 01923 USA; +1 978 750 8400. Permission to photocopy portions of any individual standard for educational classroom use can also be obtained through the Copyright Clearance Center.

Introduction

[This introduction is not part of IEEE Std 837-2002, IEEE Standard for Qualifying Permanent Connections Used in Substation Grounding.]

This standard has been written to fill a need for standardization of terminology and test requirements for permanent grounding connections.

Many types of connections are available that may be used as permanent grounding connections even though they were designed for use as power connections. This standard has been written to provide a meaningful reproducible test program that will enable connection manufacturers to qualify their products as permanent grounding connections. The users can then be reasonably assured that the qualified permanent grounding connection will be capable of performing satisfactorily over the lifetime of the substation or other installation, however, these tests are not intended for service-aged connections.

This standard addresses the parameters for testing grounding connections on aluminum, copper, steel, copper-bonded steel, galvanized steel, stainless steel, and stainless-clad steel.

Participants

The work of preparing this standard was carried out by Working Group D9 of the Distribution Substation Subcommittee, IEEE Substations Committee of the IEEE Power Engineering Society. At the time this standard was approved, the members of the working group were as follows:

Sashi G. Patel, *Chair*

Gary Di Troia, *Secretary*

H. E. Abdallah
T. M. Barnes
K. S. Chan
C. J. Daiss
D. DeCosta
F. A. Denbrock
W. K. Dick

D. L. Garrett
E. Hayes
R. P. Keil
C. C. King
D. Laird
S. Ludwig
W. M. Malone
J. Merryman

B. P. Ng
R. M. Portale
D. Smith
G. J. Steinman
C. R. Stidham
B. Story
W. K. Switzer

The following members of the balloting committee voted on this recommended practice. Balloters may have voted for approval, disapproval, or abstention.

H. E. Abdallah
William J. Ackerman
T. M. Barnes
Charles Blattner
Guru Dutt Dhingra
William Bruce Dietzman
Randall Dotson
Donald Dunn
Gary Engmann
James Gardner
D. L. Garrett
Edward Horgan
R. P. Keil

Hermann Koch
Thomas LaRose
D. Laird
Greg Luri
Gary Michel
Daleep Mohla
Kyaw Myint
Art Neubauer
B. P. Ng
Albert Parsons
Shashikant Patel
Gene Pecora

Paul Pillitteri
Percy E Pool
James Ruggieri
Anne-Marie Sahazizian
Michael Sharp
Garry Simms
David Singleton
D. Smith
Malcolm Thaden
Kenneth White
James Wilson
Peter Wong
Luis E. Zambrano S.

When the IEEE-SA Standards Board approved this standard on 11 November 2002, it had the following membership:

James T. Carlo, *Chair*
James H. Gurney, *Vice Chair*
Judith Gorman, *Secretary*

Sid Bennett
H. Stephen Berger
Clyde R. Camp
Richard DeBlasio
Harold E. Epstein
Julian Forster*
Howard M. Frazier

Toshio Fukuda
Arnold M. Greenspan
Raymond Hapeman
Donald M. Heirman
Richard H. Hulett
Lowell G. Johnson
Joseph L. Koepfinger*
Peter H. Lips

Nader Mehravari
Daleep C. Mohla
William J. Moylan
Malcolm V. Thaden
Geoffrey O. Thompson
Howard L. Wolfman
Don Wright

*Member Emeritus

Also included are the following nonvoting IEEE-SA Standards Board liaisons:

Alan Cookson, *NIST Representative*
Satish K. Aggarwal, *NRC Representative*

Andrew Ickowicz
IEEE Standards Project Editor

Contents

1.	Overview.....	1
1.1	Scope.....	1
1.2	Purpose.....	1
2.	References.....	1
3.	Definitions.....	3
4.	Qualification tests	3
5.	Performance criteria.....	4
5.1	General.....	4
5.2	Mechanical tests.....	4
5.3	Sequential tests.....	4
6.	Test procedures	8
6.1	General.....	8
6.2	Mechanical test samples	8
6.3	Sequential test samples	8
6.4	Connection description	8
6.5	Test conductors	8
6.6	Test assembly methods	8
6.7	Connection preparation.....	8
6.8	Installation.....	8
7.	Mechanical tests.....	9
7.1	General.....	9
7.2	Mechanical pullout test.....	9
7.3	Electromagnetic force test.....	10
8.	Current-temperature cycling test.....	11
8.1	General.....	11
8.2	Current-temperature cycling test.....	11
8.3	Ambient conditions.....	12
8.4	Control conductor	12
8.5	Current cycling.....	13
8.6	Current cycling loop configuration.....	14
8.7	Current cycling measurements.....	14
9.	Freeze-thaw test	15
9.1	General.....	15
9.2	Freeze-thaw test	15
9.3	Freeze-thaw test samples and their configuration.....	15
9.4	Freeze-thaw test equipment	16
9.5	Freeze-thaw test cycle.....	16

10.	Corrosion tests	16
	10.1 General	16
	10.2 Corrosion test—salt spray	16
	10.3 Corrosion test—acid (HNO ₃)	17
11.	Fault-current test	18
	11.1 General	18
	11.2 Fault-current test	18
	11.3 Fault-current test samples	18
	11.4 Fault-current test configuration.....	18
	11.5 Fault-current test duration.....	18
	11.6 Fault-current test current.....	19
	11.7 Fault-current number of surges.....	19
	11.8 Fault-current test evaluation	19
	Annex A (informative)Bibliography.....	20
	Annex B (informative)Nitric acid dilution	21
	Annex C (normative)Conductor ampacity calculation	22
	Annex D (informative)Test sequencing.....	25

IEEE Standard for Qualifying Permanent Connections Used in Substation Grounding

1. Overview

1.1 Scope

This standard provides direction and methods for qualifying permanent connections used for substation grounding. It particularly addresses the connection used within the grid system, the connection used to join ground leads to the grid system, and the connection used to join the ground leads to equipment and structures.

1.2 Purpose

The purpose of this standard is to give assurance to the user that a connection meeting the requirements of this standard will perform in a satisfactory manner over the lifetime of the installation, provided that the proper connection is selected for the application and that the connection is installed correctly. Grounding connections that meet the test criteria stated in this standard for a particular conductor size range and material should satisfy all of the criteria for connections as outlined in IEEE Std 80™-2000 [B5]¹.

2. References

This standard shall be used in conjunction with the following publications. When the following standards are superseded by an approved revision, the revision shall apply.

ASTM A363-98, Specification for Zinc-Coated (Galvanized) Steel Overhead Ground Wire.²

ASTM A510-96 (R2002), Standard Specification for General Requirements for Wire Rods and Coarse Round Wire, Carbon Steel.

ASTM A752-93 (R1998), Specification for General Requirements for Wire Rods and Coarse Round Wire, Alloy Steel (Metric).

ASTM B1-90 (R2001), Standard Specification for Hard-Drawn Copper Wire.

ASTM B2-94 (R2000), Standard Specification for Medium-Hard-Drawn Copper Wire.

ASTM B3-95 (R2001), Standard Specification for Soft or Annealed Copper Wire.

ASTM B8-99, Standard Specification for Concentric-Lay-Stranded Copper Conductors, Hard, Medium-Hard, or Soft.

¹The numbers in brackets correspond to those of the bibliography in Annex A.

²ASTM publications are available from the American Society for Testing and Materials, 100 Barr Harbor Drive, West Conshohocken, PA 19428-2959, USA (<http://www.astm.org/>).

- ASTM B49-98 (R2000), Standard Specification for Copper Rod Drawing Stock for Electrical Purposes.
- ASTM B105-94 (R2000), Standard Specification for Hard-Drawn Copper Alloy Wires for Electric Conductors.
- ASTM B117-97, Standard Practice for Operating Salt Spray (Fog) Apparatus.
- ASTM B172-95 (R2001), Standard Specification for Rope-Lay-Stranded Copper Conductors Having Bunch-Stranded Members, for Electrical Conductors.
- ASTM B173-95 (R2001), Standard Specification for Rope-Lay-Stranded Copper Conductors Having Concentric-Stranded Members, for Electrical Conductors.
- ASTM B174-95, Bunch-Stranded Copper Conductors for Electrical Conductors.
- ASTM B193-95 (R2002), Standard Test Method for Resistivity of Electrical Conductor Materials.
- ASTM B227-98 (R2002), Standard Specification for Hard-Drawn Copper-Clad Steel Wire.
- ASTM B228-98 (R2002), Standard Specification for Concentric-Lay-Stranded Copper-Clad Steel Conductors.
- ASTM B229-95 (R2002), Standard Specification for Concentric-Lay-Stranded Copper and Copper-Clad Steel Composite Conductors.
- ASTM B230-97, Standard Specification for Aluminum 1350-H19 Wire, for Electrical Purposes.
- ASTM B233-97, Standard Specification for Aluminum 1350 Drawing Stock for Electrical Purposes.
- ASTM B236-95 (R2000), Standard Specification for Aluminum Bars for Electrical Purposes (Bus Bars).
- ASTM B258-96 (R2002), Standard Specification for Standard Nominal Diameters and Cross-Sectional Areas of AWG Sizes Solid Round Wires Used as Electrical Conductors.
- ASTM B317-96 (R2000), Standard Specification for Aluminum-Alloy Extruded Bar, Rod, Pipe, and Structural Profiles for Electrical Purposes (Bus Conductor).
- ASTM B396-87 (R2000), Standard Specification for Aluminum-Alloy 5005-H19 Wire for Electrical Purposes.
- ASTM B397-85 (R1999), Concentric-Lay-Stranded Aluminum-Alloy 5005-H19 Conductors.
- ASTM B398-97, Standard Specification for Aluminum-Alloy 6201-T81 Wire for Electrical Purposes.
- ASTM B399-97, Specification for Concentric-Lay-Stranded Aluminum-Alloy 6201-T81 Conductors.
- ASTM B416-98, Standard Specification for Concentric-Lay-Stranded Aluminum-Clad Steel Conductors.
- ASTM B609-97, Standard Specifications for Aluminum 1350 Round Wire, Annealed and Intermediate Temperatures, for Electrical Purposes.
- NEMA GR 1-2001, Grounding Rod Electrodes and Grounding Rod Electrode Couplings.³

³NEMA publications are available from Global Engineering Documents, 15 Inverness Way East, Englewood, Colorado 80112, USA (<http://global.ihs.com/>).

3. Definitions

General definitions of words or terms of a technical nature not listed in this standard shall be as defined in *The Authoritative Dictionary of IEEE Standards Terms* [B4].

3.1 conductor: A metallic substance that allows a current of electricity to pass continuously along it. As used in this standard, a conductor includes cable (wire), rods (electrodes), and metallic structures.

3.2 conductor combination: The various conductors that are joined by a connection.

3.3 connection: A metallic device of suitable electric conductance and mechanical strength used to join conductors.

3.4 connection thermal capacity: The ability of a connection to withstand the amount of current required to produce a specified temperature on the control conductor without increasing the resistance of the connection beyond that specified in this standard.

3.5 control conductor: The conductor that is utilized to measure equivalent changes in temperature, size, etc., that are occurring in at least one of the conductors joined by the connection under test.

3.6 current loop cycle: The combination of conductors and connections that carries the current of the circuit under test.

3.7 equalizer: A device to provide equipotential planes for resistance measurements.

3.8 grid system: A system consisting of interconnected bare conductors buried in the earth or in concrete to provide a common ground for electrical devices and metallic structures.

3.9 permanent connection: A grounding connection that will retain its electrical and mechanical integrity for the design life of the conductor within limits established by this standard.

4. Qualification tests

A listing of the tests to be performed for all types of connections is given in Table 1. The connections shall be tested individually and sequentially, as shown in Table 1.

Table 1—Qualification test sequence and quantities^a

Test	Clause	Minimum number of samples per test ^b
Individual test group—mechanical Mechanical pullout	7.2	4
Individual test group—electromagnetic Electromagnetic force	7.3	4
Sequential test groups Current-temperature cycling Freeze-thaw Corrosion—salt spray, acid Salt spray Acid Fault current	8.1 through 8.7 9.1 through 9.5 10.2 10.3 11.1 through 11.8	4 per sequence

^aSee Annex D for additional information.

^bThese are the minimum number of connection samples of each connection design and conductor combination tested.

5. Performance criteria

5.1 General

When installed and tested in accordance with this standard, all connections shall conform to the performance criteria given in 5.2 and 5.3.

5.2 Mechanical tests

5.2.1 Pullout value criteria

The connection pullout value, when tested in accordance with 7.2, shall meet the minimum pullout values shown in Table 2, with no visible movement of the premarked conductor with respect to the connection.

5.2.2 Electromagnetic force withstand criteria

When tested in accordance with 7.3, the connection shall remain intact, with no visible movement of the premarked conductor with respect to the connection. The method for evaluating the initial connection resistance and the resistance calculation at the end of the test is the same as that for the sequential test described in 5.3.2. The resistance of the connection, calculated per 5.3.2 and tested in accordance with Clause 7, shall not increase by more than 50% (the final resistance shall not exceed 1.5 times the initial value). Resistance measurements shall be recorded in accordance with 7.3.6. The resistance values shall be corrected to 20 °C.

5.3 Sequential tests

5.3.1 Temperature criteria

The temperature of the connections tested in accordance with Clause 8 shall not exceed the temperature of the control conductor.

5.3.2 Resistance criteria

The resistance of the connection, calculated per 5.3.2.1 and tested in accordance with Clauses 8 through Clause 11 for the salt spray sequence, and Clause 8 and Clause 9 for the acid sequence, shall not be greater than the specified values when compared to the initial resistance value. Resistance measurements shall be taken in accordance with 5.3.2.3. The resistance values shall be corrected to 20 °C.

5.3.2.1 Initial resistance criteria

Resistance measurements shall be taken at the start of the testing and at intervals during the testing as indicated. The ambient temperature shall be recorded at the time of each set of resistance measurements. The initial resistance for the sample connection under test is determined as follows:

- 1) The resistance of the control conductor (R_{CC1}) shall be determined through measurement. When measuring the control conductor resistance, equalizers shall be used to establish an equipotential plane across all strands of the conductor. Equalizers are not necessary on solid conductors.

NOTE—If the conductor has a known resistivity, then the measured value shall be within 5% of the published resistance value for that conductor. If the measured resistance is outside the nominal tolerance range, there may be a problem with the test setup. Check the conductor material, conductor size, conductor hardness, equipment calibration, oxidation on conductor strands, test probe connections or other factors that can affect resistance measurements before proceeding.

The length of the control conductor (L_{CC1}) shall be taken between equalizers as shown in Figure 1.

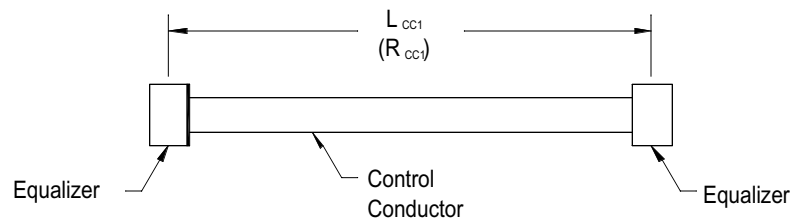

Figure 1—Control conductor resistance and length

- 2) If the connection under test is joining two types of conductors, the noncontrol conductor shall also be measured. Follow step 1) to determine L_{CC2} and R_{CC2} for the noncontrol conductor.
- 3) Assemble the test loop as described in 8.6 and shown in Figure 3.
- 4) Measure the length ($L_{Sample1}$) from an equalizer to the center of the connection, as shown in Figure 2. Then measure the length ($L_{Sample2}$) from the center of the connection to the opposite equalizer.
- 5) Measure the total resistance (R_{Total}) across the entire connection sample from equalizer to equalizer. See Figure 2.
- 6) All resistance measurements shall be temperature corrected to 20 °C before evaluating the sample connection. Equation (1) shall be used to correct the resistance measurements.

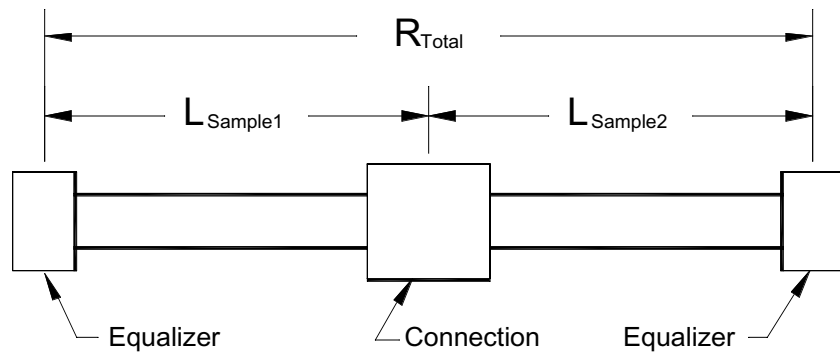

Figure 2—Connection assembly length and resistance

$$R_{20} = \frac{R_m}{[1 + \alpha_{20} (T_m - 20)]} \quad (1)$$

where

- R_m is measured resistance,
- α_{20} is thermal coefficient of resistivity at 20 °C (see Table C.1),
- T_m is temperature of the sample.

- 7) Using the corrected resistance values, determine the pass criteria of the initial sample resistance using Equation (2). The pass criteria of the initial sample is that the initial resistance of the test sample between equalizers shall not be greater than 1.1 times the resistance on an equal length conductor.

$$\frac{R_{Total}}{\left[\left(\frac{R_{CC1} L_{Sample1}}{L_{CC1}} \right) + \left(\frac{R_{CC2} L_{Sample2}}{L_{CC2}} \right) \right]} \leq 1.10 \quad (2)$$

where R_{CC1} , R_{CC2} , L_{CC1} and L_{CC2} are as shown in Figure 1 and Figure 2.

If two types of conductor are not being used, then $R_{CC2} = R_{CC1}$ and $L_{CC2} = L_{CC1}$.

5.3.2.2 Final resistance criteria

Final resistance measurements for each sample (R_{Final}) shall be measured as described in 5.3.2.3 and depicted in Figure 2 for total resistance (R_{Total}), along with the ambient temperature as required in 5.3.2.4. Final resistance measurements shall be corrected to 20 °C using Equation (1). Pass criteria for final resistance results shall be such that the corrected value of R_{Final} does not exceed 1.5 times the initial R_{Total} value for each sample tested.

5.3.2.3 Resistance measurements

Resistance measurements shall be made when the conductor temperature is at ambient temperature. The measurements shall be made across the control conductor and across each connection between potential

points located in the center of the equalizers adjacent to the connection or at the equivalent points on a solid conductor. For these measurements, a current of a sufficiently low magnitude shall be used to avoid appreciable heating.

Resistance measurements shall be taken prior to the commencement of the electromagnetic force withstand test and each test within a sequential test group. For electromagnetic force test samples, final resistance measurements shall be taken at the completion of the three applied surges. For salt spray sequence samples, final resistance measurements shall be taken after the fault-current test in Clause 11, but prior to the visual examination in 11.8. For acid sequence samples, final resistance measurements shall be taken after the freeze-thaw test in Clause 9.

5.3.2.4 Temperature correction

Ambient temperature shall be recorded concurrently with each set of resistance measurements, and the resistance shall be corrected to 20 °C. The corrected resistance shall be used in evaluating the performance of the connection.

5.3.3 Fault-current criteria

Connections tested in accordance with Clause 11 shall not melt, separate from, or move in relation to the premarked conductor. The conductor shall not fuse within 50 mm of either end of a connection under test.

Table 2—Minimum pullout values

Copper or aluminum wire size	Copper-clad steel wire	Steel wire or rod ^a	Minimum pullout value
AWG or kcmil	Number/AWG size of strands	Diameter (mm)	(N)
8	—	—	668
6	—	4.8	1335
4	—	—	1335
3	—	6.4	1335
2	7/#10	—	1335
1	—	7.9	1335
1/0	7/#8	9.5	1335
2/0	7/#7	11.1	2225
3/0	7/#6	—	2225
4/0	—	12.7	2225
250	7/#5 & 19/#9	14.3	4450
300	7/#4 & 19/#8	15.9	4450
350	—	—	4450
400	19/#7	19.1	4450
500	19/#6	—	4450
600	19/#5	22.2	8900
750	—	25.4	8900
1000	—	—	8900

^aSteel wire or rod includes copper-bonded (copper-clad) steel rod, galvanized steel, stainless steel, and stainless-clad steel. For connections involving the combination of wire and rod, use the pullout value of the wire.

6. Test procedures

6.1 General

Mechanical tests are to be conducted on new connections for pullout strength and electromagnetic withstand strength of the connection in accordance with Clause 7.

6.2 Mechanical test samples

The samples subjected to mechanical tests shall not be used for the sequential tests.

6.3 Sequential test samples

Current-temperature cycling, freeze-thaw, corrosion, and fault-current tests are to be conducted sequentially. Use the same samples for all tests conducted in accordance with Clause 8 through Clause 11.

6.4 Connection description

A description adequate for complete identification of the test connections shall be included in the test report.

6.5 Test conductors

The conductors shall conform to the following applicable standards: ASTM A363-98, ASTM A510-96, ASTM B1-90, ASTM B2-94, ASTM B3-95, ASTM B8-99, ASTM B49-98, ASTM B105-94, ASTM B172-95, ASTM B173-95, ASTM B174-95, ASTM B193-95, ASTM B227-98, ASTM B228-98, ASTM B229-95, ASTM B230-97, ASTM B233-97, ASTM B236-95, ASTM B258-96, ASTM B317-96, ASTM B396-87, ASTM B397-85, ASTM B398-97, ASTM B399-97, ASTM B416-98, ASTM B609-97, NEMA GR 1-2001.

6.6 Test assembly methods

All assembly details not specifically defined in this standard shall be completely described in the test report.

6.7 Connection preparation

Connections shall be prepared in accordance with the manufacturer's recommendations for field installation.

6.8 Installation

The method of installation and the installation tooling shall be in accordance with the manufacturers' recommendations for field installation. Unless specified otherwise in the manufacturer's instructions, the connections shall be installed so as to provide maximum stress on the connector (see Figure 3) during the current-temperature cycling and fault-current tests.

When clamping bolts are employed, they shall be tightened to the torque specified in Table 3, unless otherwise specified by the manufacturer.

Table 3—Clamping bolt tightening torque

Bolt size (in)	Stainless steel, Galvanized steel, or silicon bronze bolts (N•m)	Aluminum bolts (lubricated) (N•m)
3/8	27	19
13/32	32	23
7/16	41	27
1/2	54	34
9/16	65	43
5/8	75	54

7. Mechanical tests

7.1 General

These tests are intended to ensure the reliability of grounding systems against mechanical abuse and electromagnetic forces.

Conductor combination. For a multirange connection, mechanical pullout and electromagnetic force tests shall be performed on the connection joining the largest-to-largest and smallest-to-smallest conductors for which the connection is designed. The conductors used shall be a commercially available hard-drawn type.

NOTE—The selection of a hard-drawn conductor, rather than soft-drawn conductor, will result in a more stringent test.

7.2 Mechanical pullout test

7.2.1 Pullout test samples

A minimum of four samples of each connection and conductor combination is required, as described in 7.1, and shall be subjected to each mechanical pullout test.

7.2.2 Pullout test conditions

When placing the sample in the tensile testing machine, care shall be taken to ensure that all strands of the conductor are loaded simultaneously and in line with the connection. The length of free conductor between the gripping device and the connection shall not be less than 254 mm. If gripping of the connection is necessary, it shall be in a manner that will not influence the pullout value.

7.2.3 Pullout loading speed

The load shall be applied at a crosshead speed not exceeding 21 mm per minute per meter of sample length.

7.3 Electromagnetic force test

7.3.1 Electromagnetic force test samples

A minimum of four samples of each connection and conductor combination, as described in 7.1, shall be subjected to each electromagnetic force test.

7.3.2 Electromagnetic force test configuration

The test loop consisting of one through four test samples shall be mounted in the same plane with the bus connections, as shown in Figure 3. Equalizers shall be used according to 8.2.3, and conductor length shall be as specified in 8.2.4.

The assembled loop may be mounted on an insulated surface of appropriate size. The use of loosely fitted restraining devices is recommended. This is for safety considerations and to simulate buried ground conductors or connections to ground rods, or both. Restraining devices, such as U-bolts, used to fasten the loop to the board shall be as located in Figure 3. Use of alternate restraining devices, which also will allow free movement of the conductor, is at the option of the tester.

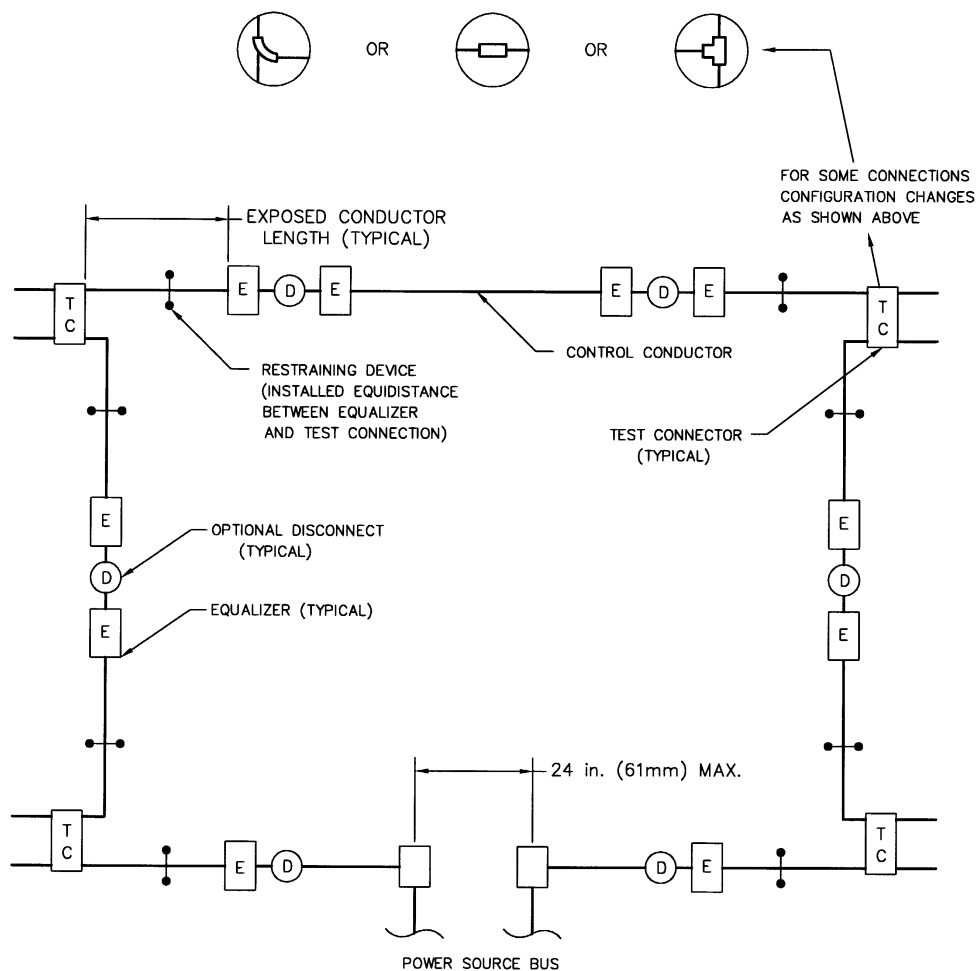

Figure 3—Typical test loop

7.3.3 Electromagnetic force test current

The magnitude of the test current for this test shall be the value of an asymmetrical current defined as follows:

- a) Calculate the rms symmetrical value of fusing current for a 1.0 second duration for the size of the control conductor (see Annex C). This is the minimum rms symmetrical test current that shall be applied.
- b) The peak value for the first half cycle of the test current shall be a minimum of 2.7 times the rms test current calculated above.
- c) The X/R ratio of the test circuit shall be such that the test current contains a dc component resulting in the first peak of the test current having an asymmetry and the magnitude as stated above. The minimum X/R ratio is 20.

7.3.4 Electromagnetic force test current duration

The actual test current duration shall be a minimum of 0.2 second in order to produce the electromagnetic force. Care should be taken to avoid a test duration approaching 1.0 second, as this is the duration for fusing the control conductor.

7.3.5 Electromagnetic force test number of surges

The test shall consist of three surges. Repeat each surge after the conductor has been allowed to cool to 100 °C or less.

7.3.6 Electromagnetic force test resistance measurements

Resistance shall be recorded for each sample, in accordance with 5.3.2.1 initially and 5.3.2.2 after the three fault surges when samples have returned to ambient temperature.

8. Current-temperature cycling test

8.1 General

This test is intended to ensure the conformance to resistance criteria of connections subjected to temperature changes caused by fluctuating currents.

8.2 Current-temperature cycling test

This test shall be the first test conducted in a series of sequential tests, as listed in Table 1 (see Clause 4).

8.2.1 Conductor combinations

When joining different types or sizes of conductors, the selection of the conductor combinations and test current shall be that which results in the highest connection-temperature while producing the conductor temperatures specified in Table 5. The following examples are provided to give some direction in maximizing the temperature of the test loop while minimizing the thermal heat-sink properties of the loop components.

Example 1: Connection for 19.1–25.4 mm copper-bonded steel rod to 6-2 AWG copper wire. From Table 6, test currents are 19.1 mm rod—570 A, 25.4 mm rod—850 A, 6 AWG wire—230 A, 4 AWG wire—320 A, and 2 AWG wire—440 A. Select a 19.1 mm copper-bonded steel rod and 2 AWG copper wire and use an initial test current of 440 A, which should achieve a 350 °C temperature on the copper-bonded rod.

Example 2: Connection for 12.7–15.9 mm stainless steel rod to 350–500 kcmil copper wire. From Table 6, test currents are 12.7 mm rod—174 A, 15.9 mm rod—210 A, 350 kcmil wire, 1441 A, and 500 kcmil wire—1860 A. Select a 15.9 mm stainless steel rod and 350 kcmil copper wire and use an initial test current of 210 A, which should achieve a 350 °C temperature on the stainless steel rod.

Example 3: Connection for 1/0–2/0 AWG copper wire to 4/0–250 kcmil copper wire. From Table 6, test currents are 1/0 AWG wire—620 A, 2/0 AWG wire—725 A, 4/0 AWG wire—1010 A, and 250 kcmil wire—1140 A. Select a 2/0 and 4/0 AWG copper wire and use an initial test current of 725 A, which should achieve a 350 °C temperature on the 2/0 AWG copper wire.

8.2.2 Test samples

Four connections of each size and type shall be required for each series of sequential tests.

8.2.3 Equalizer

Equalizers shall be installed on the stranded conductor on each side of each connection. The equalizer provides an equipotential plane for resistance measurements and prevents the influence of one connection on the other. Equalizers are not required on solid conductors.

Any form of equalizer that ensures contact of all strands of a conductor for the duration of the test may be used.

When the cables to be joined in a loop are identical, a continuous piece of cable may be used between the connections. A short compression sleeve centered between the connections may then act as the equalizer.

NOTE—Resistance measurement points on solid conductors shall be the same as those used for conductors requiring equalizers.

8.2.4 Conductor length

The exposed length of the conductor in the current cycle loop between the connection and the equalizers shall be as given in Table 4.

8.3 Ambient conditions

The current-temperature cycling tests shall be conducted in a space free of drafts at an ambient temperature of 10 °C to 40 °C.

8.4 Control conductor

A control conductor, used for the purpose of obtaining conductor temperature, shall be installed in the current cycle loop between two equalizers. It shall be of the same type and size as the conductor of those joined by the connection under test that established the highest temperature. Its length shall be the same as the total of one test sample between equalizers as shown in Figure 2.

Table 4—Conductor length from connection to equalizer

Copper wire or cable size	Aluminum wire or cable size	Steel or clad steel wire or rod	Exposed conductor length from connection to equalizer (+10%, -0.0%)
AWG or kcmil	AWG or kcmil	Diameter (mm)	(mm)
Up to 2/0	Up to 4/0	Up to 11.1	300
Over 2/0 to 500	Over 4/0 to 795	Over 11.1 to 19.1	600
Over 500	Over 795	Over 19.1	900

8.5 Current cycling

8.5.1 Current cycling period

Each cycle of the current-temperature cycling test shall consist of maintaining the minimum temperature specified in Table 5 on the control conductor for one hour and then cooling to room ambient. For suggested test currents, refer to Table 6.

8.5.2 Current cycling number of cycles

The connections shall be subjected to a minimum of 25 current cycles.

8.5.3 Current cycling test temperature

The current shall be adjusted over the first five cycles to result in a steady-state temperature on the control conductor specified in Table 5, and adjusted every five cycles thereafter as required to attain the specified steady-state temperature for a total of 25 cycles.

Table 5—Conductor temperature

Conductor	Temperature for current cycling test (°C)
Aluminum	250 °C
Copper	350 °C
Steel	350 °C
Copper-bonded steel	350 °C
Galvanized steel	250 °C
Stainless steel	350 °C

8.6 Current cycling loop configuration

Loop configuration shall provide a minimum space of 600 mm between the connected conductor, 750 mm from the floor, 1200 mm from the ceiling, and 600 mm from the walls.

A typical loop configuration is illustrated in Figure 3, but the loop may be bent back on itself in a “U” or zig-zag shape provided the above stated spacings are maintained.

8.7 Current cycling measurements

Temperature measurements for both the control conductor and the connectors shall be recorded at the beginning of the test and after every five cycles.

8.7.1 Current cycling temperature measurements

Temperature measurements shall be recorded for the connections and the control conductor near the end of the current heating period, with the current on. The temperature shall be measured by means of thermocouples permanently installed on each connection as close as possible to the point on the current path midway between the two conductors. One thermocouple shall be installed at the midpoint of the control conductor.

Table 6—Applied current levels

Current temperature cycling Suggested test currents for conductor temperature specified in Table 5					
Copper or aluminum wire size AWG or kcmil	Copper wire amperes	Aluminum wire amperes	Copper-clad steel wire		
			Number/AWG strand size	30% conductivity amperes	40% conductivity amperes
8	165	103	7/#8	280	320
6	230	143	7/#7	330	375
4	320	198	7/#6	385	440
3	375	234	7/#5	450	515
2	440	276	19/#9	460	520
1	520	324	7/#4	515	590
1/0	620	382	19/#8	530	610
2/0	725	451	19/#7	620	700
3/0	855	534	19/#6	720	815
4/0	1010	627	19/#5	835	940
250	1140	708			
300	1295	806			
350	1441	900			
400	1574	984			
500	1860	1159			
600	2095	1322			
750	2471	1545			
1000	3010	1895			

Nominal diameter ^a	Copper-bonded steel rod ^b	Steel galvanized steel wire and rod	Stainless steel wire and rod
(mm)	Amperes	Amperes	Amperes
4.8	—	77	58
6.4	—	108	83
7.9	—	136	107
9.5	—	162	131
11.1	—	186	153
12.7	350	207	174
14.3	—	226	193
15.9	425	243	210
19.1	570	274	242
22.2	—	300	282
25.4	850	324	293

^aActual rod diameter may vary from the nominal diameter (see NEMA GR-1-2001) and could require minor current adjustment during testing.

^bCopper bonded steel rod based on 0.254 mm copper thickness.

9. Freeze-thaw test

9.1 General

This test is intended to ensure the conformance to resistance criteria of the connections subjected to repeated cycles of freezing and thawing in water.

9.2 Freeze-thaw test

This test shall be the second test in a series of sequential tests as listed in Table 1.

9.3 Freeze-thaw test samples and their configuration

Test connections are the same test samples subjected to the current-temperature cycling test in accordance with Clause 8.

Test samples can be tested in a series loop or as individual test samples.

9.4 Freeze-thaw test equipment

Containers resistant to freezing and heating temperatures and suitable for holding samples in a series loop configuration or as individual samples shall contain enough water to submerge and cover the connection by a minimum of 25.4 mm of water.

9.5 Freeze-thaw test cycle

9.5.1 Freeze-thaw test temperatures

The freezing and thawing cycle shall consist of lowering the temperature of the test connection samples to -10 °C or lower, and raising the temperature to at least 20 °C. The test samples shall remain at both the low and high temperature for at least two hours during each cycle.

9.5.2 Freeze-thaw number of cycles

The connection shall be subjected to a minimum of 10 freeze-thaw cycles.

10. Corrosion tests

10.1 General

The corrosion tests are designed to evaluate the corrosion resistance of connections. The acid and salt spray test sequences are independent of each other. Both sequential tests shall be performed for connection qualification to this standard.

10.2 Corrosion test—salt spray

10.2.1 General

This test method covers the procedure for determining the corrosive effects of salt spray (sodium chloride) on connections.

10.2.2 Salt spray corrosion test

This test shall be the third test in a series of sequential tests, as shown in Table 1.

10.2.3 Salt spray test samples

The test connection samples shall be the same connections tested in accordance with Clause 8 and Clause 9.

10.2.4 Salt spray test applicable standard

The test shall be performed according to ASTM B117-97 except Clause 5 and Clause 6 shall be modified to accommodate conductor and connection design combinations being tested.

10.2.5 Salt spray test duration

The test shall be conducted for a minimum of 500 hours.

10.2.6 Salt spray test post-corrosion conditioning

After completion of the salt spray test, the test samples shall be rinsed in fresh water. Prior to taking resistance measurements, samples shall be heated for 1 hour at 100 °C to ensure dryness and then be returned to ambient temperature.

10.2.7 Salt spray test visual evaluation

Connections and conductors shall be visually inspected for the type of corrosion, if any, and this information shall be recorded in the test data, such as uniform corrosion, pitting, and galvanic action.

10.3 Corrosion test—acid (HNO₃)

10.3.1 General

This test method covers the procedure for determining the corrosive effects of acid attack (nitric acid) on connections.

10.3.2 Acid corrosion test

This test shall be the third test in a series of sequential tests, as shown in Table 1.

10.3.3 Acid test samples

The test connection samples shall be the same connections tested in accordance with Clause 8 and Clause 9.

10.3.4 Acid test submersion and samples

The test samples and conductor up to the equalizers shall be submerged in the acid solution. The equalizers may or may not be included in the submerged section. This setup shall position the connection sample midway between exposed loop portions from the acid solution.

The control conductor shall be the same as used in Clause 8 and Clause 9, and the submerged portion shall be equal in length to that of the submerged sample loop section. The beginning resistance of plated/clad control conductors shall be recorded for reference.

10.3.5 Acid test solution parameters

The acid solution shall be a 10% by volume concentration of nitric acid HNO₃ and distilled water H₂O. See Annex B.

Solution volume shall be such as to provide a minimum ratio of 1 liter of 10% solution to 1.613E4 mm² of submerged test sample surface area. The surface area includes the surface of all strands of the conductor submerged in the solution.

The ambient temperature shall be 20 °C to 35 °C.

10.3.6 Acid test submersion time

Simple conductor loops (i.e., conductors of a single, uniform material such as copper) shall be submerged in the acid solution for a time that will reduce the control conductor to 80% (minimum of 20% reduction) of its original cross-sectional area. The reduction shall be determined by weight reduction per unit length or increase in resistance of the control conductor.

Compound simple conductor loops (i.e., two different single, uniform materials such as a copper conductor joined with a steel conductor) shall be submerged in the acid solution for a time that will reduce the faster corroding of the materials to 80% (minimum of 20% reduction) of its original cross-sectional area. The reduction shall be determined by weight reduction per unit length or increase in resistance of the control conductor.

When a conductor loop combination includes plated or clad conductors, the minimum submersion time shall be either 1) the same as stated above for simple conductor loops, or 2) the point at which the base material of the plated/clad conductor first becomes exposed anywhere along its length with a minimum continuous area of 10 mm², whichever event occurs first.

10.3.7 Acid test post-corrosion conditioning

After completion of the acid test, the test samples shall be rinsed in fresh water and heated for 1 hour at 100 °C to ensure dryness, and then be returned to ambient temperature.

10.3.8 Acid test evaluation

Connections and conductors shall be visually inspected for the type of corrosion, if any, and this information shall be recorded in the test data, such as uniform corrosion, pitting, and galvanic action. The final resistance of plated/clad control conductors shall be recorded for reference.

11. Fault-current test

11.1 General

The purpose of this test is to determine if connections conditioned in previous tests will withstand fault-current surges.

11.2 Fault-current test

This test shall be the fourth test in a series of sequential tests as shown in Table 1.

11.3 Fault-current test samples

The test samples shall be the same connection tested in accordance with Clause 8 through Clause 10.

11.4 Fault-current test configuration

The test samples shall be mounted in a loop as shown in Figure 3 or as individual test samples as shown in Figure 2. The control conductor shall also be tested to 11.2. Use of fastening devices is at the option of the tester.

11.5 Fault-current test duration

The fault duration shall be a minimum of 10 s.

11.6 Fault-current test current

The symmetrical rms fault current shall be 90% of the fusion current for the remaining cross-sectional area of the control conductor calculated for a 10 s duration. See Annex C.

NOTE—Ninety percent of the fusion current is established to prevent loss of the conductor and provide a method of measuring resistance readings after three repeated fault surges.

11.7 Fault-current number of surges

The test shall consist of three surges. Repeat each surge after the conductor has been allowed to cool to 100 °C or less.

NOTE—If the conductor fuses during the fault-current testing, and the connection under test has been determined not to be the cause of the failure, the conductor may be spliced to complete the fault-current testing. Only one such fusing along a given section between any two equalizers shall be allowed. The test shot shall be redone for the full 10 s.

11.8 Fault-current test evaluation

Each connection shall be taken apart or dissected, or both, and visually inspected for melting or other damaging effects to the connection, and the results shall be recorded.

Annex A

(informative)

Bibliography

- [B1] ANSI/UL 467-1984, Safety Standard for Grounding and Bonding Equipment.
- [B2] ANSI/UL 486A-1982, Safety Standard for Wire Connectors and Soldering Lugs for Use with Copper Conductors.
- [B3] ANSI/UL 486B-1982, Safety Standard for Wire Connectors for Use with Aluminum Conductors.
- [B4] IEEE 100™, *The Authoritative Dictionary of IEEE Standards Terms*, Seventh Edition.
- [B5] IEEE Std 80™-2000, IEEE Guide for Safety in AC Substation Grounding.
- [B6] Mixon, J., *Corrosion Resistance Test for Copper and Copper Alloy Connector Products Used on Grounding Grid Conductors and Electrodes*. Harrisburg, PA: AMP, Inc., June 27, 1979.
- [B7] Mixon, J., *Exploratory Acid Corrosion Tests*. Harrisburg, PA: AMP, Inc., Oct. 5, 1978.
- [B8] NACE TM0169-95, Laboratory Corrosion Testing of Metals for the Process Industries.
- [B9] NEMA CC1-1993, Electrical Power Connectors for Substations.
- [B10] NEMA CC3-1973 (R 1983), Connectors for Use Between Aluminum or Aluminum/Copper Overhead Conductors.
- [B11] Sverak, J. G., "Safe substation grounding, Part II," *IEEE Transactions on Power Apparatus and Systems*, vol. PAS-101, pp. 4006–4023, Oct. 1982 (IEEE Paper 82 WM 180-8).
- [B12] Sverak, J. G., "Sizing of ground conductors against fusing," *IEEE Transactions on Power Apparatus and Systems*, vol. PAS-100, pp. 51–59, Jan. 1981 (IEEE Paper F80 256-8).
- [B13] VDE Standard 0142.64, Regulation for Earthings in AC Installation with Rated Voltages Above 1 kV (Germany).

Annex B

(informative)

Nitric acid dilution

NOTE—Nitric acid, HNO_3 , is usually purchased as 70% concentrate and is adjusted to the percentage requirement for the user by the following calculation per liter of solution.

$$\text{Volume of HNO}_3 \text{ (mL)} = \frac{1000\text{mL} \times 10\%}{70\%} \text{ per liter}$$

$$\text{Volume of HNO}_3 \text{ (mL)} = 143 \text{ mL of HNO}_3 \text{ per liter}$$

143 mL of 70% nitric acid concentrate + 857 mL of water = 1 liter of 10% acid test solution.

Annex C

(normative)

Conductor ampacity calculation (see IEEE Std 80-2000 [B5] and Sverak, J. G. [B12])

The following equation can be used to calculate the ampacity for any conductor for which the material constants are known, or can be determined by calculation:

$$I = A \sqrt{\left(\frac{TCAP \cdot 10^{-4}}{t_c \alpha_r \rho_r} \right) \ln \left(\frac{K_0 + T_m}{K_0 + T_a} \right)}$$

where

I	is rms current in kA,
A	is conductor cross section in mm ² ,
T_m	is maximum allowable temperature in °C,
T_a	is initial conductor temperature in °C,
T_r	is reference temperature for material constants in °C,
α_0	is thermal coefficient of resistivity at 0 °C,
α_r	is thermal coefficient of resistivity at reference temperature T_r ,
ρ_r	is resistivity of the ground conductor at reference temperature T_r in μΩ-cm,
K_0	is $1/\alpha_0$, or $(1/\alpha_r) - T_r$ in °C,
t_c	is time of current flow in seconds,
$TCAP$	is thermal capacity factor in joules/cm ³ /°C.

Material constants for conductors used with connections covered by this standard are listed in Table C.1. Note that α_r and ρ_r are defined for the same reference temperature of r degrees Celsius. Table C.1 provides data for α_r and ρ_r at 20 °C. $TCAP$ is defined as $4.184 \cdot SH \cdot SW$ where SH is the specific heat in cal/gram/°C and SW is the specific weight in gram/cm³.

Introducing a new factor, β , which is defined as

$$\beta = \frac{\alpha_r \cdot \rho_r \cdot 10^4}{TCAP}$$

and rearranging the equation yields the following new equation for conductor ampacity:

$$I = A \sqrt{\frac{\ln \left(\frac{K_0 + T_m}{K_0 + T_a} \right)}{\beta t_c}} \text{ in kA}$$

NOTE—When calculating fusing current, the fusing temperature in accordance with Table C.1 shall be used for T_m . For bimetallic conductors, the material with the lower fusing temperature is given in Table C.1.

Example 1: Electromagnetic force test current calculation

Example solving for the minimum electromagnetic-force test current (I_{test}), and the asymmetrical peak current (I_{peak}) of 100% conductivity copper, 500 kcmil conductor:

Let

$$\begin{aligned} A &= 253 \text{ mm}^2 \\ T_m &= 1083 \text{ }^\circ\text{C} \\ T_a &= 40 \text{ }^\circ\text{C} \\ K_0 &= 234 \text{ }^\circ\text{C} \\ \beta &= 19.8 \\ t &= 1.0 \text{ s} \end{aligned}$$

$$I_{test} = 253 \cdot \sqrt{\frac{\ln\left(\frac{234+1083}{234+40}\right)}{19.8 \cdot 1.0}}$$

$$I_{test} = 50.4 \text{ kA} = 50\,400 \text{ A rms}$$

and the first peak of the asymmetrical test current, I_{peak} , is

$$I_{peak} = 2.7 \cdot I_{test} = 2.7 \cdot 50\,400 = 136\,000 \text{ A peak.}$$

Example 2: Fault-current test current calculation

Example solving for the fuse current (I_{fuse}) and the minimum fault-current test current (I_{test}) at 1083 °C for #4/0 AWG 100% conductivity, copper conductor (assume no corrosion to conductor):

Let

$$\begin{aligned} A &= 107.2 \text{ mm}^2 \text{ for #4/0 AWG conductor} \\ T_m &= 1083 \text{ }^\circ\text{C} \\ T_a &= 40 \text{ }^\circ\text{C} \\ K_0 &= 234 \text{ }^\circ\text{C} \\ \beta &= 19.8 \\ t &= 10 \text{ s} \end{aligned}$$

$$I_{fuse} = 107.2 \cdot \sqrt{\frac{\ln\left(\frac{234+1083}{234+40}\right)}{19.8 \cdot 10.0}}$$

$$I_{fuse} = 9.5 \text{ kA} = 9\,500 \text{ A rms}$$

The minimum fault-current rms test current, I_{test}

$$\begin{aligned} &= 90\% \cdot 9\,500 \\ &= 8\,600 \text{ A} \end{aligned}$$

Table C.1—Material constants

Description	Material conductivity (%)	α_r factor @ 20 °C	$K_0 (1/\alpha_0)$ @ 0 °C	Fusing temperature (°C)	ρ_r @ 20 °C ($\mu\Omega\text{-cm}$)	TCAP factor effective value ($\text{J}/\text{cm}^3/\text{°C}$)
Copper, annealed Soft drawn	100.0	0.00393	234	1083	1.724	3.422
Copper, commercial Hard drawn	97.0	0.00381	242	1084	1.777	3.422
Copper-clad Steel core, wire	40.0	0.00378	245	1084	4.397	3.846
Copper-clad Steel core, wire	30.0	0.00378	245	1084	5.862	3.846
Copper bonded Steel core, rod ^a	20.0	0.00378	245	1084	8.621	3.846
Aluminum, EC grade	61.0	0.00403	228	657	2.862	2.556
Aluminum, 5005 alloy	53.5	0.00353	263	660	3.223	2.598
Aluminum, 6201 alloy	52.5	0.00347	268	660	3.284	2.598
Aluminum-clad Steel core	20.3	0.00360	258	660	8.481	2.670
Steel, No. 1020	10.8	0.0016	605	1510	15.9	3.284
Stainless steel, No. 304	2.4	0.0013	749	1400	72.0	4.032
Stainless-clad Stainless core, rod ^b	9.8	0.0016	605	1400	17.5	4.443
Zinc-coated Steel core	8.6	0.0032	293	419	20.1	3.931

^aCopper-bonded steel rod based on 0.254 mm copper thickness.

^bStainless-clad steel rod based on 0.508 mm No. 304 stainless steel thickness over No. 1020 steel core.

Annex D

(informative)

Test sequencing

Table 1 identifies all testing and samples required for qualifying connections per this standard. Figure C.1 and Figure C.2 will assist in identifying each test and measurement/evaluation point throughout the multi-step test programs.

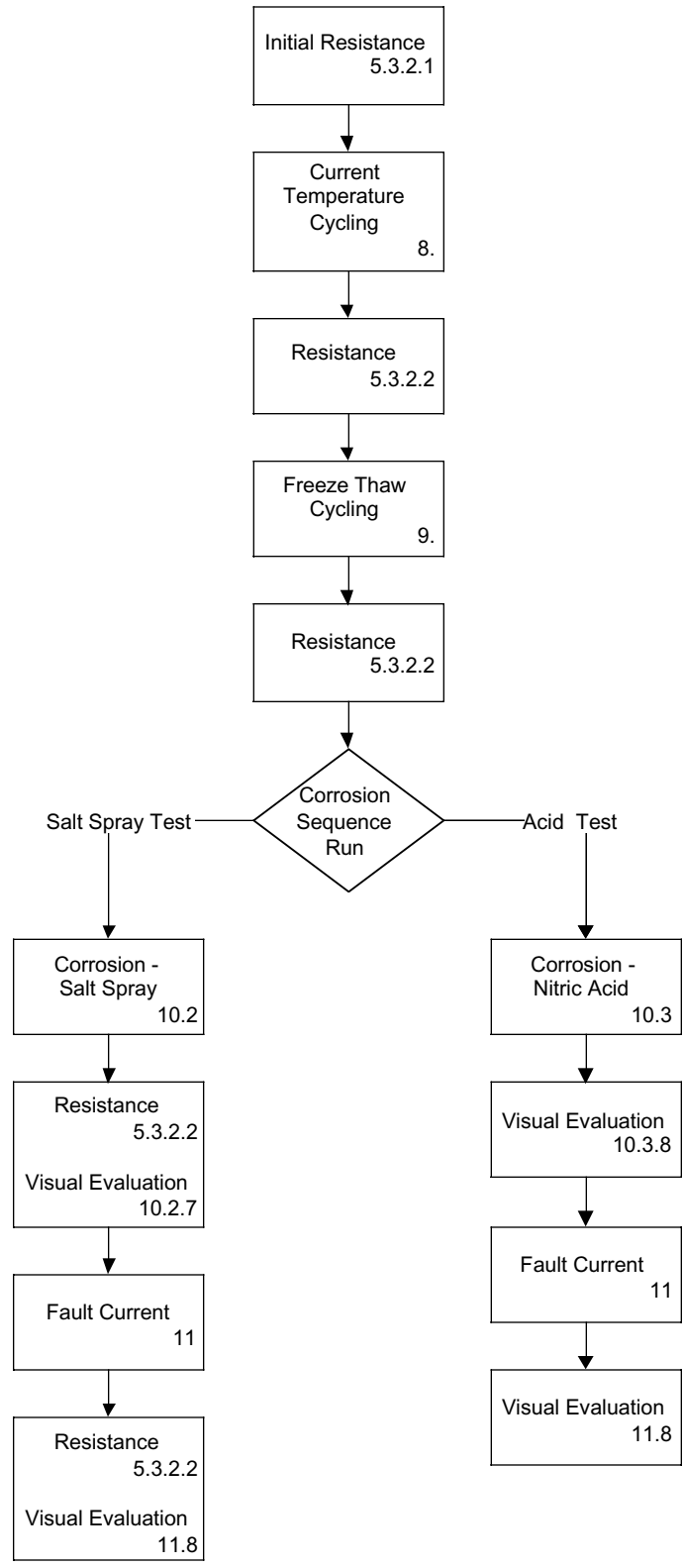

Figure C.1—Corrosion sequence flow diagram

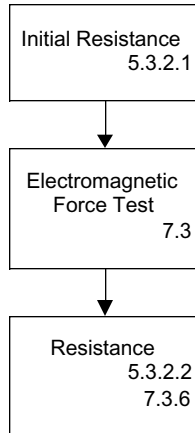

Figure C.2—Electromagnetic force test flow diagram