

IEEE Application Guide for AC High-Voltage Circuit Breakers Rated on a Symmetrical Current Basis

Sponsor

Switchgear Committee
of the
IEEE Power Engineering Society

Approved 16 September 1999

IEEE-SA Standards Board

Abstract: This guide covers the application of indoor and outdoor high-voltage circuit breakers rated above 1000 V for use in commercial, industrial, and utility installations. It deals with usage under varied service conditions, temperature conditions affecting continuous current compensation, reduced dielectrics, reclosing derating as applicable, calculation of system short-circuit current, compensation at different X/R ratios, detailed calculations with application curves, out-of-phase switching, and general application.

Keywords: ambient compensation/emergency operation, capacitor switching, high-voltage circuit breakers, indoor drawout, line closing, load current switching, outdoor, pollution level creepage distance, power frequency, rated maximum voltage, short-circuit consideration, TRV, transformer current switching

The Institute of Electrical and Electronics Engineers, Inc.
3 Park Avenue, New York, NY 10016-5997, USA

Copyright © 2000 by the Institute of Electrical and Electronics Engineers, Inc.
All rights reserved. Published 31 May 2000. Printed in the United States of America.

Print: ISBN 0-7381-1827-3 SH94796
PDF: ISBN 0-7381-1828-1 SS94796

No part of this publication may be reproduced in any form, in an electronic retrieval system or otherwise, without the prior written permission of the publisher.

IEEE Standards documents are developed within the IEEE Societies and the Standards Coordinating Committees of the IEEE Standards Association (IEEE-SA) Standards Board. Members of the committees serve voluntarily and without compensation. They are not necessarily members of the Institute. The standards developed within IEEE represent a consensus of the broad expertise on the subject within the Institute as well as those activities outside of IEEE that have expressed an interest in participating in the development of the standard.

Use of an IEEE Standard is wholly voluntary. The existence of an IEEE Standard does not imply that there are no other ways to produce, test, measure, purchase, market, or provide other goods and services related to the scope of the IEEE Standard. Furthermore, the viewpoint expressed at the time a standard is approved and issued is subject to change brought about through developments in the state of the art and comments received from users of the standard. Every IEEE Standard is subjected to review at least every five years for revision or reaffirmation. When a document is more than five years old and has not been reaffirmed, it is reasonable to conclude that its contents, although still of some value, do not wholly reflect the present state of the art. Users are cautioned to check to determine that they have the latest edition of any IEEE Standard.

Comments for revision of IEEE Standards are welcome from any interested party, regardless of membership affiliation with IEEE. Suggestions for changes in documents should be in the form of a proposed change of text, together with appropriate supporting comments.

Interpretations: Occasionally questions may arise regarding the meaning of portions of standards as they relate to specific applications. When the need for interpretations is brought to the attention of IEEE, the Institute will initiate action to prepare appropriate responses. Since IEEE Standards represent a consensus of all concerned interests, it is important to ensure that any interpretation has also received the concurrence of a balance of interests. For this reason, IEEE and the members of its societies and Standards Coordinating Committees are not able to provide an instant response to interpretation requests except in those cases where the matter has previously received formal consideration.

Comments on standards and requests for interpretations should be addressed to:

Secretary, IEEE-SA Standards Board
445 Hoes Lane
P.O. Box 1331
Piscataway, NJ 08855-1331
USA

Note: Attention is called to the possibility that implementation of this standard may require use of subject matter covered by patent rights. By publication of this standard, no position is taken with respect to the existence or validity of any patent rights in connection therewith. The IEEE shall not be responsible for identifying patents for which a license may be required by an IEEE standard or for conducting inquiries into the legal validity or scope of those patents that are brought to its attention.

IEEE is the sole entity that may authorize the use of certification marks, trademarks, or other designations to indicate compliance with the materials set forth herein.

Authorization to photocopy portions of any individual standard for internal or personal use is granted by the Institute of Electrical and Electronics Engineers, Inc., provided that the appropriate fee is paid to Copyright Clearance Center. To arrange for payment of licensing fee, please contact Copyright Clearance Center, Customer Service, 222 Rosewood Drive, Danvers, MA 01923 USA; (978) 750-8400. Permission to photocopy portions of any individual standard for educational classroom use can also be obtained through the Copyright Clearance Center.

Introduction

(This introduction is not part of IEEE Std C37.010-1999, IEEE Application Guide for AC High-Voltage Circuit Breakers Rated on a Symmetrical Current Basis.)

This guide is a revision of IEEE Std C37.010-1979 and contains substantive changes due to the efforts of three coordinated Working Groups on revision and coordination of IEEE Std C37.04, IEEE Std C37.09, and IEEE Std C37.010.

Although much of the approach of IEEE Std C37.010-1979 has been retained, many editorial changes, significant enhancements, and some fundamental changes have been made.

Some of the major issues include

- Updating to modern interruption technologies.
- Listing of low-temperature concerns.
- Inclusion of creepage distance material from IEC 60071-2: 1976¹.
- Acknowledgment that historic voltage range factor K has been changed to 1.0 for new circuit breakers designs, which allows simplification of the rating structure and circuit breaker application. It is recognized that circuit breakers rated in accordance with older standards, having voltage range factor K differing from 1.0, are still available and will be in service for many years. If there is a K factor, it should be recorded on the circuit breaker nameplate. For circuit breakers that have a voltage range factor K differing from 1.0, the user should refer to IEEE Std C37.04-1979, IEEE Std C37.06-1987, IEEE Std C37.09-1979, IEEE Std C37.010-1979, or earlier editions of the same documents for rating, application, and testing information.
- Recommendations on applying application margins to rated interrupting time.
- Recognition that “Tripping Delay” is no longer a rating. Permissible tripping delay will be based on the short-time (closed) current rating of the circuit breaker.
- Inclusion of reclosing derating factors for air magnetic and oil circuit breakers as stated in 5.9.1.
- Handling of large dc time constants greater than 45 ms ($X/R > 17$ at 60 Hz or 14 at 50 Hz). Terminology has been converted from the total current basis to a peak current and percent dc basis. The derating methods are unchanged. However, many current interruption technologies may have limitations beyond the total current basis of 5.2 of IEEE Std C37.010-1979. Concerns exist about “expiration of interrupting window, which is the difference between the minimum and maximum arcing times,” and performance of some interrupters on a large major loop of current just after being “conditioned” by a small minor loop. Warning statements have been incorporated to consult the manufacturer for long dc time constant capabilities of the particular design being considered. The 1979 method has been retained in the guide to serve as an upper limit for long dc time constant application. It is generally agreed that if circuit breakers are applied below 80% of their short-circuit rating (equivalent of one step down on the R10 series) that dc time constants are not much of a concern to the circuit breaker.
- Addition (as an option) of a recommendation on applying resistance-capacitance “snubber circuits” for medium voltage breakers switching loaded or unloaded transformers.
- Addition of Annex B, special application circuit breakers for ac motor starting (information previously in NEMA SG-4).

Ongoing work issues include

- Working dielectric withstand. Presently, the dielectric ratings of a circuit breaker are used for dimensioning the insulation system of the breaker. A concern exists that a breaker which has done switching and fault clearing may have a reduced dielectric withstand. Users need to know what insulation withstand should be assigned to a circuit breaker for insulation coordination. In IEEE Std C37.010-1999, the working dielectric withstand is assumed to be the rated dielectric test value.
- A more comprehensive treatment on derating for long dc time constants.

¹Information on references can be found in Clause 2.

The IEEE Std C37.010-1999 Working Group had the following membership:

Yasin I. Musa, Chair

Roy W. Alexander*
 W. J. Bill Bergman
 Matthew T. Brown
 Patrick J. DiLillo
 Randall L. Dotson

David E. Galicia
 R. Jean Jean
 David Lemmerman
 Jeffrey H. Nelson
 E. J. O'Donnell
 Mark Puccinelli

Gary H. Schauffler
 Donald E. Seay
 Devki N. Sharma
 Alan D. Storms
 Charles L. Wagner

*Chair emeritus

Upon recommendation of the IEEE Switchgear Committee, the proposed American National Standard was voted on by the Standards Committee C37 on Power Switchgear and was subsequently approved as an American National Standard on 13 January 2000.

The Accredited Standards Committee on Power Switchgear, C37, that reviewed and approved this document, had the following members at the time of approval:

Eldridge R. Byron, Chair

Andrew K. McCabe, Vice Chair, High-Voltage Standards

J. C. Scott, Vice Chair, Low-Voltage Standards

David L. Swindler, Vice Chair, IEC Activities

<i>Organization Represented</i>	<i>Name of Representative</i>
Edison Electric Institute (EEI)	T. E. Bruck (<i>Alt.</i>) D. E. Galicia Joseph L. Koepfinger D. G. Komassa Gary Miller J. H. Provanzana
Institute of Electrical and Electronics Engineers	Steve C. Atkinson (<i>Alt.</i>) L. R. Beard Peter W. Dwyer David G. Kumbera (<i>Alt.</i>) Lawrence V. McCall (<i>Alt.</i>) A. Monroe David F. Peelo M. Dean Sigmon
MET Electrical Testing Association	Leonard Frier
National Electric Contractors Association	Darrell Harwood
National Electrical Manufacturers Association	Eldridge R. Byron (<i>Alt.</i>) Ruben D. Garzon Gary T. Jones (<i>Alt.</i>) William Kracht Lee H. Miller T. W. Olsen Gerald Sakats (<i>Alt.</i>) David L. Stone David L. Swindler (<i>Alt.</i>)
Tennessee Valley Authority	David N. Reynolds
Underwriters Laboratories	Paul J. Notarian
US Department of the Army, Office of the Chief of Engineers	John A. Gilson
US Department of the Navy, Construction Battalion Center.....	Romulo R. Nicholas
Western Area Power Administration.....	Gerald D. Birney

This standard was developed by the High-Voltage Circuit Breaker Subcommittee of the IEEE Switchgear Committee. At the time this standard was completed, the members of this subcommittee were as follows:

Ruben D. Garzon, *Chair*

Denis Dufournet
Harold L. Hess
Nigel P. McQuin

Gordon O. Perkins
David N. Reynolds
R. Kirkland Smith

Alan D. Storms
David L. Swindler
John Tannery

The following members of the balloting committee voted on this standard:

Roy W. Alexander
Steve Atkinson
Michael P. Baldwin
W. J. Bill Bergman
Steven A. Boggs
Anne Bosma
Matthew T. Brown
John H. Brunke
Ted Burse
Eldridge R. Byron
Carlos L. Cabrera-Rueda
Raymond L. Capra
James F. Christensen
Stephen P. Conrad
Patrick J. DiLillo
Alexander Dixon
Randall L. Dotson
J. J. Dravis
Denis Dufournet
P. W. Dwyer
Douglas J. Edwards
Gary R. Engmann
Jay Fischer
Charles G. Garner
Ruben D. Garzon
Mietek T. Glinkowski
Dave Gohil
Keith I. Gray
David F. Gray

Ian J. Harvey
Harold L. Hess
Richard H. Hulett
Jerry M. Jerabek
Donald E. Joslyn
Aftab H. Khan
Joseph L. Koepfinger
P. L. Kolarik
David G. Kumbera
Stephen R. Lambert
Thomas W. LaRose
W. E. Laubach
David Lemmerman
Albert Livshitz
R. W. Long
Jeffrey D. Lord
Deepak Mazumdar
L. V. McCall
Neil McCord
Nigel P. McQuin
Peter Meyer
Daleep C. Mohla
F. J. Muench
Yasin I. Musa
Jeffrey H. Nelson
Paul J. Notarian
T. W. Olsen
Miklos J. Orosz

Gordon O. Perkins
David N. Reynolds
Hugh C. Ross
Gerald Sakats
Hazairin Samaulah
Roger A. Sarkinen
Gary H. Schauffler
Larry H. Schmidt
Donald E. Seay
Devki N. Sharma
M. Dean Sigmon
H. M. Smith
R. Kirkland Smith
James E. Smith
Bodo Sojka
Guy St. Jean
David Stone
Alan D. Storms
William M. Strang
David Swindler
Stan H. Telander
Frederick C. Teufel
Malcolm V. Thaden
Thomas J. Tobin
Michael Wactor
Charles L. Wagner
Thomas E. Wiedman
Larry E. Yonce
Janusz Zawadzki

When the IEEE-SA Standards Board approved this standard on 16 September 1999, it had the following membership:

Richard J. Holleman, *Chair*
Donald N. Heirman, *Vice Chair*
Judith Gorman, *Secretary*

Satish K. Aggarwal
Dennis Bodson
Mark D. Bowman
James T. Carlo
Gary R. Engmann
Harold E. Epstein
Jay Forster*
Ruben D. Garzon

James H. Gurney
Lowell G. Johnson
Robert J. Kennelly
E. G. "Al" Kiener
Joseph L. Koepfinger*
L. Bruce McClung
Daleep C. Mohla
Robert F. Munzner

Louis-François Pau
Ronald C. Petersen
Gerald H. Peterson
John B. Posey
Gary S. Robinson
Akio Tojo
Hans E. Weinrich
Donald W. Zipse

*Member emeritus

Also included is the following nonvoting IEEE-SA Standards Board liaison:

Robert E. Hebner

Noelle D. Humenick
IEEE Standards Project Editor

Contents

1. Scope.....	1
2. References.....	1
3. Definitions.....	3
4. General service conditions.....	3
4.1 Usual service conditions	3
4.2 Unusual service conditions	3
4.3 Mechanical considerations for outdoor circuit breakers.....	7
5. Application considerations.....	7
5.1 Maximum voltage for application.....	8
5.2 Voltage range factor.....	8
5.3 Frequency.....	8
5.4 Continuous current.....	8
5.5 Rated dielectric withstand.....	22
5.6 Standard operating duty	22
5.7 Interrupting time	23
5.8 Permissible tripping delay T (determined by short-time current test duration).....	24
5.9 Reclosing time	25
5.10 Short-circuit current rating.....	29
5.11 Transient recovery voltage.....	30
5.12 Load current switching capability and life (repetitive operation).....	31
5.13 Capacitance current switching	31
5.14 Line closing (line-closing switching surge factor).....	31
5.15 Conditions of use with respect to the out-of-phase switching current rating	32
5.16 Shunt reactor current switching	33
5.17 Transformer current switching	33
5.18 Mechanical endurance	33
5.19 Rated control voltage	34
5.20 Fluid operating pressure.....	34
5.21 Insulating oil for circuit breaker	34
5.22 Closed pressure system (gas-filled)	34
6. Short-circuit considerations	34
6.1 System short-circuit currents	34
6.2 Selection of applicable circuit breaker ratings.....	36
6.3 Methods for calculating system short-circuit currents.....	36
6.4 Electrical quantities used	47
Annex A (informative)—Basis for E/X method corrected for ac and dc decrements in the calculation of short-circuit currents	54
Annex B (informative) — Special application circuit breakers for ac motor starting.....	67
Annex C (informative) — Bibliography.....	71

.....

IEEE Application Guide for AC High-Voltage Circuit Breakers Rated on a Symmetrical Current Basis

1. Scope

This application guide applies to the ac indoor and outdoor high-voltage circuit breakers rated in accordance with the methods given in IEEE Std C37.04-1999, listed in IEEE Std C37.06-1997, and tested in accordance with IEEE Std C37.09-1999. Circuit breakers rated and manufactured to meet other standards should be applied in accordance with application procedures adapted to their specific ratings or applications.

2. References

This standard shall be used in conjunction with the following standards. When the following standards are superseded by an approved revision, the revision shall apply, except where more than one version of a standard is referenced.

AIEE 55-1953, Guide for Temperature Correlation in the Connection of Insulated Wire and Cables to Electronic Equipment.¹

IEC 60071-2: 1976, Insulation coordination—Part 2: Application guide.²

IEEE Std 4-1995, IEEE Standard Techniques for High-Voltage Testing.³

IEEE Std 32-1972 (Reaff 1997), IEEE Standard Requirements, Terminology, and Test Procedures for Neutral Grounding Devices.

¹AIEE Std 55-1953 has been withdrawn; however, copies can be obtained from Global Engineering, 15 Inverness Way East, Englewood, CO 80112-5704, USA, tel. (303) 792-2181 (<http://global.ihs.com/>).

²IEC publications are available from the Sales Department of the International Electrotechnical Commission, Case Postale 131, 3, rue de Varembe, CH-1211, Genève 20, Switzerland/Suisse (<http://www.iec.ch/>). IEC publications are also available in the United States from the Sales Department, American National Standards Institute, 11 West 42nd Street, 13th Floor, New York, NY 10036, USA.

³IEEE publications are available from the Institute of Electrical and Electronics Engineers, 445 Hoes Lane, P.O. Box 1331, Piscataway, NJ 08855-1331, USA (<http://standards.ieee.org/>).

IEEE Std C57.106-1991, IEEE Guide for Acceptance and Maintenance of Insulating Oil in Equipment.

IEEE Std 693-1997, IEEE Recommended Practices for Seismic Design of Substations.

IEEE Std C37.04-1979 (Reaff 1988), IEEE Standard Rating Structure for AC High-Voltage Circuit Breakers Rated on a Symmetrical Current Basis.

IEEE Std C37.04-1999, IEEE Standard Rating Structure for AC High-Voltage Circuit Breakers Rated on a Symmetrical Current Basis.

IEEE Std C37.06-1987, IEEE Schedule of Preferred Rating and Related Required Capabilities for AC High-Voltage Circuit Breakers Rated on Symmetrical Current Basis.

IEEE C37.06-1997, American National Standard for Switchgear—AC High-Voltage Circuit Breakers Rated on a Symmetrical Current Basis—Preferred Ratings and Related Required Capabilities.

IEEE Std C37.06.1-1997, American National Standard Trial-Use Guide for High-Voltage Circuit Breakers Rated on a Symmetrical Current Basis—Designated “Definite Purpose for Fast Transient Recovery Voltage Rise Time.”

IEEE Std C37.09-1979 (Reaff 1988), IEEE Standard Test Procedure for AC High-Voltage Circuit Breakers Rated on a Symmetrical Current Basis.

IEEE Std C37.09-1999, IEEE Standard Test Procedure for AC High-Voltage Circuit Breakers Rated on a Symmetrical Current Basis.

IEEE Std C37.010-1979 (Reaff 1988), IEEE Application Guide for AC High-Voltage Circuit Breakers Rated on a Symmetrical Current Basis.

IEEE Std C37.011-1994, IEEE Application Guide for Transient Recovery Voltage for AC High-Voltage Circuit Breakers Rated on a Symmetrical Current Basis.

IEEE Std C37.012-1979 (Reaff 1988), IEEE Application Guide for Capacitance Current Switching for AC High-Voltage Circuit Breakers Rated on a Symmetrical Current Basis.

IEEE Std C37.015-1993, IEEE Application Guide for Shunt Reactor Switching.

IEEE Std C37.20.2-1993, IEEE Standard for Metal-Clad and Station-Type Cubical Switchgear.

IEEE Std C37.24-1986, IEEE Guide for Evaluating the Effect of Solar Radiation on Outdoor Metal-Enclosed Switchgear.

IEEE Std C37.81-1989 (Reaff 1992), IEEE Guide for Seismic Qualification of Class 1E Metal-Enclosed Power Switchgear Assemblies.

IEEE Std C37.100-1992, IEEE Standard Definitions for Power Switchgear.

IEEE Std C57.13-1993, IEEE Standard Requirements for Instrument Transformers.

IEEE Std C57.19.00-1991, IEEE Standard General Requirements and Test Procedure for Outdoor Power Apparatus Bushings.

IEEE Std C62.2-1987 (Reaff 1994), IEEE Guide for the Application of Gapped Silicon-Carbide Surge Arresters for Alternating Current Systems.

IEEE Std C62.22-1991, IEEE Guide for the Application of Metal-Oxide Surge Arresters for Alternating-Current Systems.

3. Definitions

The terms and definitions applicable to this standard and to the related standards for ac high-voltage circuit breakers shall be in accordance with IEEE Std C37.100-1992. These definitions are not intended to embrace all possible meanings of the terms. They are intended solely to establish meaning of terms used in power switchgear.

4. General service conditions

4.1 Usual service conditions

Service conditions for circuit breakers are defined in IEEE Std C37.04-1999. These conditions specify limits in altitude and in ambient temperature and other environmental conditions.

4.1.1 Provision for system growth

Power system facilities must be expanded or modified from time to time to serve larger loads. This usually results in higher values of short-circuit current. Therefore, sufficient allowance for expected future increase in short-circuit current is advisable.

4.1.2 System design

Methods of limiting the magnitude of short-circuit currents or reducing the probability of high-current faults by system design are outside the scope of this guide. Such methods should be considered where short-circuit currents approach the maximum capability of the circuit breakers. Many station design features may depend on available circuit breaker ratings. System design should take into account the necessity for circuit breaker inspection and maintenance.

4.2 Unusual service conditions

Some unusual service conditions are listed in 4.2.1 through 4.2.14. Special installation, operation, and maintenance provisions should be considered where these conditions are encountered.

4.2.1 Abnormal temperatures

The use of apparatus in an ambient temperature lower than $-30\text{ }^{\circ}\text{C}$ or higher than $40\text{ }^{\circ}\text{C}$ shall be considered as special.

Temperatures below $-30\text{ }^{\circ}\text{C}$ create a harsh environment for circuit breakers. Many users in colder climates routinely experience $-50\text{ }^{\circ}\text{C}$ temperatures. The following should be considered for low ambient temperature environments:

- Operating times may be slower than rated times (typically 1–3 ms slower than rated).
- Wax precipitation of insulating oil “cloud point,” oil becomes extremely viscous, creating excessive drag.
- Humidity in air system freezes, sticking operating and blast valves.

- Liquefaction of sulfur hexafluoride (SF₆) may occur, necessitating derating of interrupting ratings and dielectric ratings unless heaters are utilized.
- Embrittlement of plastics, composites, and metals may lead to failure during breaker operation.
- Hydraulic or SF₆ dampers may be affected.
- Special lubricants may be required to prevent extreme sluggishness.
- Density and pressure switches may malfunction or may be out of range.
- Heaters for the mechanism may be required.

4.2.2 Applications at altitudes above 1000 m (3300 ft)

Correction factors for voltage and for continuous current to be applied to circuit breaker ratings and related required capabilities when a circuit breaker is installed and operated at altitudes above 1000 m (3300 ft) are being developed by a Common Clause Working Group. See IEEE Std 4-1995 for interim guidance.

NOTE—It is generally acceptable not to derate the continuous current capability of a circuit breaker for high altitude applications because at the higher elevations the ambient temperature is significantly lower than the normal maximum of 40 °C. In this case, the procedure outlined in 5.4.3 should be followed to determine the suitability of the circuit breaker.

Derating the breaker's dielectric capabilities is not always necessary and usually not the most economical approach. The need for derating depends on whether arresters are used on both sides of the circuit breaker (line and load) and on their protective levels. If at least a 20% margin exists between the arrester protective level and the breaker basic lightning impulse insulation level (BIL), no derating should be necessary.

4.2.3 Exposure to excessive dust or abrasive, magnetic, or metallic dust

- a) Totally enclosed nonventilated equipment or compartments may be necessary.
- b) Where current-carrying equipment designed for ventilated operation is enclosed in a nonventilated compartment, derating may be necessary.
- c) Installation in a positive pressure room with appropriate filtration equipment may be necessary.

4.2.4 Exposure to explosive mixtures of dust or gases

Standard circuit breakers are not designed for use in explosive atmospheres. For this type of service, special consideration should be given in conjunction with requirements of applicable regulatory bodies so that acceptable equipment is selected.

4.2.5 Exposure to abnormal vibration, shock, or tilting

Standard circuit breakers are designed for mounting on substantially level structures free from excessive vibration, shock, or tilting. Where any of these abnormal conditions exists, recommendations for the particular breaker's application should be obtained from the manufacturer.

Circuit breakers being applied in locations of known seismic activity should be specified with seismic withstand requirements per IEEE Std 693-1997 and IEEE Std C37.81-1989 as necessary for indoor drawout and outdoor circuit breakers. The user should specify the operational requirements, including whether functionality must be maintained

- Before and after the seismic event or
- Before, during, and after the seismic event

4.2.6 Seasonal or infrequent use

Equipment stored or de-energized for long periods should be protected against accelerated deterioration. Before energizing for service, operating performance and insulation integrity should be checked.

4.2.7 Exposure to damaging fumes, vapor, steam, oil vapors, salt air, and hot and humid climate

- a) Provision may be necessary to avoid condensation on all electrical insulation and current-carrying parts.
- b) Bushings with extra creep distance may be required.
- c) In cases where particular exposure represents a hazard to insulation integrity, special maintenance including insulator washing may be necessary.
- d) Materials resistant to fungus growth may be required.
- e) Installation in a positive pressure room system with appropriate filtration equipment may be required.
- f) Installation of heaters in mechanism cabinets and indoor switchgear may be required.

4.2.8 Exposure to excessive pollution

Creepage distance (see IEEE Std C37.100-1992) over external insulation is listed in IEEE Std C37.06-1997. These minimum values are for the normal conditions (i.e., light pollution level) of atmospheric contamination and provide generally satisfactory service operation under these conditions.

For standardization, four levels of pollution are qualitatively defined, from light pollution to very heavy pollution.

Table 1 gives, for each level of pollution, an approximate description of some typical corresponding environments. Other extreme environmental conditions exist that merit further consideration, e.g., snow and ice in heavy pollution, heavy rain, and arid areas.

For each level of pollution described in Table 1, the corresponding minimum nominal specific creepage distance, in millimeters per kilovolt (phase-to-ground) of the highest voltage for equipment is given in Table 2. This table is intended to replace Table 2 of IEC 60071-2: 1976.

Experience has shown that the criterion of “minimum nominal specific creepage distance,” which implies linearity under pollution between withstand voltage and creepage distance, applies to most insulators used on existing systems.

Some insulators specially shaped for particular kinds of pollution may not satisfy these conditions even though they perform satisfactorily in service.

4.2.9 Exposure to unusual transportation or storage conditions

Exposure to unusual transportation or storage conditions should be considered special.

4.2.10 Unusual space limitations

Unusual space limitations should be considered special.

Table 1—Environmental examples by pollution level

Pollution level	Examples of typical environments
Light	Areas without industries and with low density of houses equipped with heating plants. Areas with low density of industries or houses but subjected to frequent winds and/or rainfall. Agricultural areas. ^a Mountainous areas. All these areas shall be situated at least 10–20 km from the sea and shall not be exposed to winds directly from the sea. ^b
Medium	Areas with industries not producing particularly polluting smoke and/or with average density of houses equipped with heating plants. Areas with high density of houses and/or industries but subjected to frequent winds and/or rainfall. Areas exposed to wind from the sea but not too close to the coast (at least several kilometers distant). ^b
Heavy	Areas with high density of industries and suburbs of large cities with high density of heating plants producing pollution. Area close to the sea or in any case exposed to relatively strong winds from the sea. ^b
Very heavy	Areas generally of moderate extent, subjected to conductive dusts and to industrial smoke producing particularly thick conductive deposits. Areas generally of moderate extent, very close to the coast and exposed to sea-spray or to very strong and polluting winds from the sea. Desert areas, characterized by no rain for long periods, exposed to strong winds carrying sand and salt, and subjected to regular condensation.

^aThe use of fertilizers by spraying or the burning of crop residues can lead to a higher pollution level due to dispersal by wind.

^bDistances from seacoast depend on the topography of the coastal area and on the extreme wind conditions.

Table 2—Minimum nominal specific creepage distance by pollution level

Pollution level	Minimum nominal specific creepage distance (mm/kV line-to-ground)
Light	28
Medium	35
Heavy	44
Very heavy	54

NOTES

1—In very lightly polluted areas, nominal specific creepage distances lower than 28 mm/kV can be used depending on the service experience. A lower limit seems to be 21 mm/kV.

2—In the case of exceptional pollution severity, a nominal specific creepage distance of 54 mm/kV may not be adequate. Depending on service experience and/or on laboratory test results, a higher value of nominal specific creepage distance can be used, but in some instances the practicability of washing or greasing may have to be considered.

4.2.11 Unusual operating duty, frequency of operation, and difficulty of maintenance

Unusual operating duty, frequent operation, and difficult maintenance should be considered special.

4.2.12 Normally open

Circuit breakers operated normally open but energized may require surge protection against lightning and switching voltage transient surges. If the circuit breakers contain grading capacitors, the manufacturer should be advised of the normal open-gap voltage stress.

Open tie breakers used under out-of-phase voltage conditions may be stressed by voltage up to 2.0 per unit across the open contacts. Such applications should be reviewed with the manufacturer.

4.2.13 Short-circuit current with asymmetry greater than 100%

Short-circuit current with asymmetry greater than 100% should be considered special.

4.2.14 Nonstandard reclosing (see IEEE Std C37.04-1999)

Nonstandard reclosing should be considered special.

4.3 Mechanical considerations for outdoor circuit breakers

4.3.1 Foundation loading

The circuit breaker should be firmly attached to a suitable foundation that supports the dead weight and any applicable dynamic loads on the circuit breaker (e.g., wind loads, terminal connection loads, seismic loads, ice loads).

4.3.2 Terminal connection loading (line pull)

Circuit breaker terminals are designed only to accept nominal mechanical loads as would be adequate to support relatively short leads. The required capabilities are listed in IEEE Std C37.04-1999. Care must be taken not to exceed these loads under any expected environmental conditions. Exceeding the mechanical load on the terminals can result in leaks, circuit breaker misoperation, or mechanical failure of the terminal. Flexible cable connections to the terminals are often most appropriate. If rigid connections are used, care must be taken to prevent thermal expansion of the rigid connection from producing excessive stress on the terminal.

5. Application considerations

In the application of circuit breakers to electrical systems, careful attention must be given to many items of technical importance to assure that a misapplication does not occur. In the usual application, the principal function of the circuit breaker is to carry load current and interrupt short-circuit current. However, it may be used for frequent load, exciting current, or capacitive current switching. In some cases, switching requirements may be the determining factor in selection rather than the requirements of short-circuit current interruption. Special attention must also be given to applications where frequent operations are essential.

In the selection of a circuit breaker, consideration must be given to the future as well as to the present needs for interrupting capacity and for current-carrying capability. These considerations include possible connected circuit changes, such as additions of supplemental cooling means for transformers or connection of multiple cable or overhead lines to the breaker, or possible future transfer of the circuit breaker from its initial position to some other location.

Various types of indoor and outdoor circuit breakers are available for use, classified by their interruption technologies. Some of these types include vacuum, oil, air magnetic, two-pressure air blast, and two-pressure and single-pressure SF₆. Each interruption technology has its own set of strengths and weaknesses and,

therefore, its own set of application considerations. The preferred ratings listed in IEEE Std C37.06-1997 may not be available in all interruption technologies, so the required ratings will limit the users' choice of interruption technologies. The choice of interruption technology may be influenced by switching frequency, special load switching (capacitor or reactor), contaminated atmosphere, environmental considerations, maintenance, ease of handling the interrupting medium, monitoring capabilities, and electrical life.

5.1 Maximum voltage for application

The operating voltage and the power-frequency recovery voltage should not exceed the rated maximum voltage because this maximum is the upper limit for continuous operation.

5.2 Voltage range factor

The voltage range factor K defined in earlier standards has been changed to 1.0 for future circuit breakers, which allows simplification of the rating structure and circuit breaker application by eliminating the voltage range factor completely. However, it is recognized that circuit breakers rated in accordance with older standards and having voltage range factor K differing from 1.0 are still available and will be in service for many years. If there is a K factor, it should be noted on the circuit breaker nameplate. For circuit breakers that have a voltage range factor K differing from 1.0, the user should refer to IEEE Std C37.04-1979, IEEE Std C37.06-1987, IEEE Std C37.09-1979, and IEEE Std C37.010-1979 (or earlier editions of the same documents) for rating, application, and testing information.

5.3 Frequency

Rated power frequencies for circuit breakers are 50 Hz and 60 Hz. Calculations used in this guide are based on 60 Hz.

Interruption of all currents on systems operating at frequencies other than rated frequency may require modification of mechanisms to change the speed of opening or may require a change in interrupting ratings of the circuit breakers.

At other frequencies, some circuit breaker types may not have a sufficiently long interruption window to interrupt successfully.

The manufacturer should be consulted for applications at frequencies differing from 50 Hz or 60 Hz.

5.4 Continuous current

Circuit breakers are designed for normal application where the sustained load current does not exceed the rated continuous current, the altitude above sea level is 1000 m (3300 ft), or less, and the ambient temperature does not exceed 40 °C. Rated continuous current of a circuit breaker should not be exceeded under normal operation except for short periods, such as when starting motors or synchronous condensers or energizing cold loads or for conditions covered by 5.4.3.

5.4.1 Normal operation

The criteria to be followed when making an application are as follows:

- a) Breakers designed for installation in an enclosure may be applied without derating.
- b) Breakers designed for use in open rooms and outdoors cannot be used in enclosures without derating or retesting to ensure that none of their temperature limits is exceeded.

- c) As far as temperature limits are concerned, any nonenclosed high-voltage circuit breaker may be used with cables having an 85 °C or lower temperature limit, provided that the temperature limit of the cable insulation is not exceeded. Indoor drawout circuit breakers are applied in accordance with IEEE Std C37.20.2-1993, and a 90 °C cable limit is recognized. Among the methods of reducing temperature at cable connections are
 - 1) Operating the breaker at a continuous current sufficiently below its rating.
 - 2) Using a section of oversize conductor or a special terminal connector ahead of the cable to reduce the temperature at the cable terminal (see AIEE 55-1953).
- d) The possible adverse effect on or by closely associated equipment operating at a higher or a lower temperature than the breaker should be examined.
- e) When a circuit breaker is properly selected for continuous current operation, it may also be used for starting such equipment as motors, synchronous condensers, and cold loads. Under this condition, the continuous current rating may be momentarily exceeded without causing damage to the circuit breaker.

5.4.2 Rated continuous current for capacitor banks

When a high-voltage circuit breaker is used in a circuit supplying static capacitors, the continuous current rating should be selected to include the effects of

- Operation at voltages below and up to 10% above the capacitor rated voltage.
- The positive tolerance in capacitance of static capacitors (−0%+15%).
- The additional heating caused by harmonic currents.
- The effect of grounded or nongrounded neutral connection of the capacitor bank.

In the absence of specific information, it will usually be conservative to use 1.25 times the nominal capacitor current at rated capacitor voltage for nongrounded neutral operation or 1.35 times the nominal current for grounded neutral operation.

5.4.3 Load current carrying capability under various conditions of ambient temperature and load

5.4.3.1 General

Circuit breakers are designed for normal application in accordance with IEEE Std C37.04-1999, where the sustained load current does not exceed the rated continuous current and the ambient temperature does not exceed 40 °C. The rated continuous current is based on the maximum permissible total temperature limitations of the various parts of the circuit breaker when it is carrying rated current at an ambient temperature of 40 °C. The total temperature of these parts under service conditions depends both on the actual load current and the actual ambient temperature. It is, therefore, possible to operate at a current higher than rated continuous current when the ambient temperature is less than 40 °C, provided that the allowable total temperature limit is not exceeded. Similarly, when the ambient temperature is greater than 40 °C, the current must be reduced to less than rated continuous current to keep total temperatures within allowable limits.

Operation at a current higher than rated continuous current will usually cause the allowable temperature limitations to be exceeded and should be avoided except in these instances:

- For short periods, such as in the starting of motors or synchronous condensers or when energizing cold loads. Generally, the time duration of this type of current increase is short enough that it does not raise temperatures significantly.
- When operating at an ambient temperature below 40 °C, as covered in 5.4.3.2.
- For short periods following operation at a current less than that permitted by the existing ambient temperature, as covered in 5.4.3.3.

The method of calculating the allowable current at an ambient temperature above 40 °C is given in 5.4.3.2. For some high ambient temperature conditions, it may not be practical to reduce current sufficiently to keep the total temperatures within their allowable limits. Forced air cooling of metal enclosed switchgear is covered in IEEE Std C37.20.2-1993 and will help in many cases. Temperature limits of associated equipment such as cables and current transformers must be considered. Effect of solar radiation must also be considered (see IEEE Std C37.24-1986). Where ambient temperature is below the minimum limit of -30 °C, special lubricants may be required, and additional heater capacity beyond that normally used should be provided in mechanism enclosures. Whenever freezing temperatures occur, precautions may be necessary to dry the air in pneumatic systems to avoid condensation and freezing.

5.4.3.2 Continuous load current capability based on actual ambient temperature

Enclosed circuit breakers are covered by IEEE Std C37.20.2-1993 for ambient compensation only. Emergency load current capability is **not** available. The continuous current that a nonenclosed circuit breaker can carry at a given ambient temperature without exceeding its total temperature limitations is given by the following formula:

$$I_a = I_r \left[\frac{\theta_{\max} - \theta_a}{\theta_r} \right]^{1/1.8}$$

where

- I_a is allowable continuous load current at the actual ambient temperature θ_a (I_a is not to exceed two times I_r) (A),
- I_r is rated continuous current (A),
- θ_{\max} is allowable hottest-spot total temperature ($\theta_{\max} = \theta_r + 40$ °C) (°C),
- θ_a is actual ambient temperature expected (between -30 °C and 60 °C) (°C),
- θ_r is allowable hottest-spot temperature rise at rated current (°C).

NOTE—The temperature rise of a current-carrying part is proportional to an exponential value of the current flowing through it. Experience has shown that although the exponent may have different values, depending on breaker design and components within a breaker, it generally is in the range of 1/1.6 to 1/2.0. The exponent value of 1/1.8 represents a compromise that is suitable for this application guide.

The constructional features of a circuit breaker dictate the appropriate values of θ_{\max} and θ_r to be used in the calculation. The major components of a circuit breaker have several different temperature limitations, which are specified in standards as follows:

Circuit breaker component	IEEE standard	
	Number	Clause
Circuit breaker insulating materials, main contacts, conducting joints, etc.	C37.04-1999	5.3.2
Current transformers	C57.13-1993	4.6

The values of temperature limitations specified in these various standards are summarized in IEEE Std C37.04-1999. In order that none of these limitations be exceeded when the load current is adjusted to the value permitted by the actual ambient temperature, the values for θ_{\max} and θ_r should be determined as follows:

- a) If the actual ambient is less than 40 °C, the component with the highest specified values of allowable temperature limitations should be used for θ_{\max} and θ_r .
- b) If the actual ambient is greater than 40 °C, the component with the lowest specified values of allowable temperature limitations should be used for θ_{\max} and θ_r .

The use of these values in the calculation will result in an allowable continuous current that will not cause the temperature of any part of the circuit breaker to exceed the permissible limits.

NOTE—Although circuit breakers are designed to carry rated current continuously while exposed to an ambient temperature of 40 °C, most circuit breakers in service are subjected to a much less severe ambient temperature condition that varies with time of day and season of year. The average outdoor air temperature during any 24 h period is usually 5 °C to 10 °C lower than the maximum, and the maximum is usually less than 40 °C. This fact is one important reason for the long life that circuit breakers historically have demonstrated. Continuous operation at rated current and at an ambient temperature of 40 °C likely would result in a life somewhat shorter than usually experienced.

The user is cautioned that this guide is intended to cover situations where the circuit breaker is used at its total temperature limitations infrequently (a few occasions in the expected lifetime), for relatively short periods of time (perhaps a few days).

The manufacturer should be consulted if operation at maximum allowable temperature is required at frequent intervals or over extended periods of time.

It may not be necessary to include the extreme values of highest and lowest allowable temperature limitation, refer to IEEE Std C37.04-1999 for summary of temperature limitation for circuit breaker components.

The lowest value is for circuit breaker parts handled by the operator in the normal course of duty. The highest value generally is for external surfaces of a circuit breaker not accessible to an operator in the normal course of duty (see IEEE Std C37.04-1999). In many cases, overheating of these external parts beyond the specified allowable limitations will not impair circuit breaker performance or expected life. If these parts are neglected, a higher value of permissible continuous load current can be obtained from the calculation. In most cases, this higher value of current may safely be used. However, in some circuit breaker designs, gaskets or other components may be located near such inaccessible external surfaces and would be damaged if overheated. The use of 80 °C rise dry-type current transformers would place a further limit on the allowable current for operation at an ambient of less than 40 °C. Evaluation of the breaker design should be made to determine whether these extreme values of temperature limitation are acceptable, and the manufacturer should be consulted.

Table 3 lists the calculated values of I_d/I_r for each specified temperature limit for the various component parts of the circuit breaker over a range of typical ambient temperatures. The allowable current in any given situation can be estimated from Table 3 or may be calculated directly from the formula given at the beginning of this subclause.

Example 1: Consider an SF₆ circuit breaker with silver-coated contacts, American National Standard bushings, and 65 °C rise current transformers. When operating at an ambient temperature of 25 °C, the current could be increased by a factor corresponding to the component with the highest temperature rise. In this case, these components are the silver-coated contacts with a maximum temperature limit of 105 °C (refer to IEEE Std C37.04-1999 Table 1); and according to Table 3, the factor of increase is 1.12 times the rated current.

When operating at an ambient temperature of 50 °C, the current must be reduced by a factor that corresponds to the component with the lowest temperature limit. In this case, the components are the bushings and the current transformers, with a temperature rise limit of 65 °C; and according to Table 3, the reduction factor is 0.91.

Example 2: Consider an oil circuit breaker with silver-to-silver contacts, American National Standard bushings, and with 55 °C rise current transformers. When the ambient temperature is 25 °C, the continuous current can be increased by a factor of 1.12. This factor of increase corresponds to the component with the highest temperature limit, which in this case are the bushings and the current transformers.

Table 3—Ratios of (I_a/I_r) for various ambient temperatures

Maximum ambient temperature (°C)	Limiting temperature of different breaker components								
	θ_{max}	50	70	80	85	90	105	110	150
	θ_r	10	30	40	45	50	65	70	110
60	—	0.54	0.68	0.72	0.75	0.81	0.82	0.89	a
50	—	0.79	0.85	0.87	0.88	0.91	0.91	0.95	a
40	1.00	1.00	1.00	1.00	1.00	1.00	1.00	1.00	
30	1.46	1.17	1.13	1.11	1.10	1.08	1.07	1.05	b
25	1.66	1.25	1.19	1.17	1.15	1.12	1.11	1.08	b
20	1.84	1.32	1.25	1.22	1.20	1.16	1.15	1.10	b
10	2.00	1.47	1.36	1.32	1.29	1.23	1.22	1.14	b
0	2.00	1.60	1.46	1.42	1.38	1.30	1.29	1.19	b
−10	2.00	1.72	1.56	1.51	1.46	1.37	1.34	1.23	b
−20	2.00	1.84	1.66	1.60	1.54	1.43	1.41	1.28	b
−30	2.00	1.95	1.75	1.68	1.61	1.50	1.46	1.32	b

^aFor limiting current, use lowest θ_r and θ_{max} .

^bFor limiting current, use highest θ_r and θ_{max} .

If the ambient temperature was 50 °C, the reduction should be included. In case of doubt, the factor would be 0.85, corresponding to the component with the lowest temperature limit, which in this case is the top oil.

Example 3: Consider an oilless circuit breaker with silver-to-silver contacts, in air, with 55 °C rise current transformers, and with terminals connected to 85 °C insulated cable. When the ambient temperature is 25 °C, the current can be increased by a factor of 1.12, corresponding to the temperature rise limitations of 65 °C of the silver-to-silver contacts and the current transformers.

If the ambient temperature was 50 °C, the reduction factor would be 0.87 corresponding to the temperature rise limitation of 45 °C of the connected cable.

Current transformers that form part of a circuit breaker assembly or that are normally considered a part of the breaker installation will usually have heating characteristics similar to those of the circuit breaker. The continuous current permitted by the formula will not cause overheating of a current transformer connected to a ratio tap corresponding to rated current of the circuit breaker. However, if a lower ratio tap is used, the expected secondary current must be evaluated in terms of the continuous thermal-rating factor of the current transformer. The effect of the secondary current on apparatus connected to the current transformer terminals should also be considered.

5.4.3.3 Short-time load current capability

When a circuit breaker has been operating at a current level below its allowable continuous load current I_a , it is possible to increase the load current for a short time to a value greater than the allowable current without exceeding the permissible temperature limitations. The length of time that the short-time load current I_s can be carried depends on these factors:

- a) The magnitude of current I_s to be carried.
- b) The magnitude of initial current I_i carried prior to application of I_s .
- c) The thermal-time characteristics of the circuit breaker.

The time duration of the short-time current may be calculated directly or may be obtained as described by Figure 1. The time duration of the current I_s determined in one of these ways will not cause the total temperature limits of the circuit breaker to be exceeded, provided that these requirements are fulfilled:

- The circuit breaker, and in particular the main contacts, shall have been well maintained and in essentially new condition.
- The value used for the current I_i is the maximum current carried by the breaker during the 4 h period immediately preceding the application of current I_s .
- At the end of the time period, the current I_s is reduced to a value that is no greater than the current I_a .
- The value of current I_s is limited to a maximum value of two times rated continuous current I_r .

NOTE—If $\theta_s < \theta_{\max}$ the loading is an acceptable steady state. In other words, the allowable time is indefinite. This should be checked before trying to use Figure 1 or directly calculating the allowable duration of I_s .

5.4.3.3.1 Determination of allowable time for I_s , by using Figure 1

One method for determining the allowable duration of current I_s is shown in Figure 1. The values of time obtained from the figure are given in “time constant units.” The actual time is determined by multiplying the time constant units by the proper thermal time constant listed in Table 4.

Table 4—Typical thermal time constants

Circuit breaker listed in IEEE Std C37.06-1987	Typical time constant τ (h)
Table 1	0.5
Table 2	0.5
Table 3	0.5

Example: A 1200 A oil circuit breaker with silver-to-silver contacts and American National Standard bushings is operating at 1000 A ($I_i = 1000$ A). It is desired to increase the current to 1600 A ($I_s = 1600$ A) for a short time. The maximum ambient temperature expected is 25 °C. For how long a time can the circuit breaker carry this current?

The allowable continuous current is determined according to 5.4.3.2. Since the ambient is less than 40 °C, the highest temperature rise limitation of 65 °C is used, the temperature rise limit of the bushing. From Table 3, the ratio of 1.12 is determined for the ambient temperature of 25 °C. Therefore, $I_a = 1.12 \times 1200 = 1344$ A.

The ratio (I_i/I_s) is (1000/1600) = 0.625. The corresponding value t_i from Figure 1 is 0.58 time constant units. The ratio (I_a/I_s) is (1344/1600) = 0.84. The corresponding value t_a from Figure 1 is 1.31 time constant units. The period of time for which the excess current can be carried $t_a - t_i = 1.31 - 0.58 = 0.73$ time constant units. The actual time is obtained by multiplying this value by the thermal time constant of 0.5 h taken from Table 4 (0.73 \times 0.5 h) = 0.365 h or about 22 min. After this time, the current must be reduced to no more than 1344 A in order to prevent overheating of the bushings.

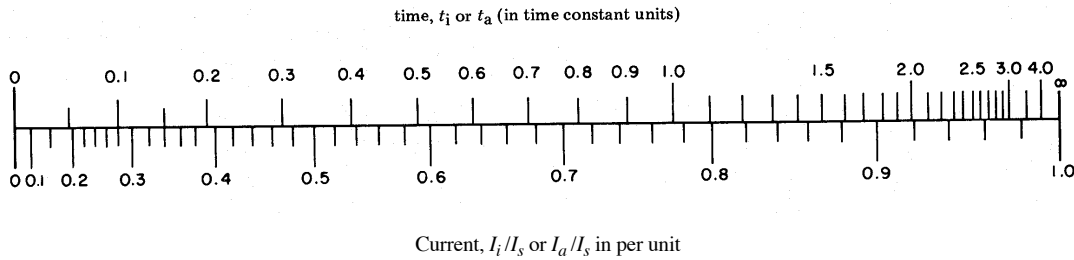

Required initial data:

Initial steady state current	I_i
Allowable continuous load current based on actual ambient temperature (from 5.4.3.2)	I_a
Desired short-time load current	I_s

Calculation procedure:

- 1) Determine I_i/I_s per unit initial current
- 2) From chart determine corresponding time t_i
- 3) Determine I_a/I_s per unit allowable continuous current
- 4) From chart determine corresponding time allowable t_a
- 5) Calculate $t_a - t_i =$ time (in time constant units) that breaker can carry, starting from initial continuous current of I_i with ambient temperature and permitting continuous operation at I_a .

NOTE—This procedure and the design of this chart are based on the following assumptions:

- a) At constant current, the temperature approaches its steady state value at an exponential rate. During any time interval equal to the thermal time constant of the circuit breaker, the temperature rise will be equal to 63.2% of the remaining increment of possible increase existing at the start of the period. This is represented by the “time” scale at the top of the chart.
- b) The temperature of a breaker part increases as the 1.8 power of the current increase. This is represented by the current scale at the bottom of the chart. Here, the current in per unit value is plotted to a scale representing the temperature produced by that current.

Figure 1—Current–time relationship to determine short-time load-current capability of high-voltage circuit breakers

5.4.3.3.2 Determination of allowable time for I_s by direct calculation

The allowable duration of current I_s may be calculated directly. While the chart method is quicker and simpler than hand calculation of these equations, the increasing availability of digital computers makes it desirable to provide the details of these calculations. These equations may be easily written in a computer language so that many sets of conditions may be analyzed quickly. The program also should then be immediately available for use at a future time.

These equations are used to calculate the time duration t , for a short-time load current I_s :

$$t_s = \tau \left[-1n \left\{ 1 - \frac{\theta_{\max} - Y - \theta_a}{Y[(I_s/I_i)^{1.8} - 1]} \right\} \right]$$

$$Y = (\theta_{\max} - 40 \text{ } ^\circ\text{C}) (I_i / I_r)^{1.8}$$

where

- θ_{\max} is allowable hottest-spot total temperature from IEEE Std C37.04-1999 (°C),
- θ_a is actual ambient expected (between -30 °C and 60 °C) (°C),
- I_i is initial current carried prior to application of I_s (A) (the maximum current carried by the breaker during the 4 h period immediately preceding the application of current I_s),
- I_s is short-time load current (A),
- I_r is rated continuous current (A),
- τ is thermal time constant of the circuit breaker from Table 4 (h),
- t_s is permissible time for carrying current I_s at ambient θ_a after initial current I_i (in same units as τ).

NOTE—These equations are derived in the following manner:

Let

- θ_s = total temperature that would be reached if current I_s were applied continuously at ambient θ_a (°C)
- θ_i = total temperature due to continuous current I_i at ambient θ_a (°C)
- θ_t = total temperature at some time t after current is raised from I_i to I_s (°C)

Then

$$\theta_t = (\theta_s - \theta_i)(1 - e^{-t/\tau}) + \theta_i$$

Let $\theta_t = \theta_{\max}$; solve for t .

Then

$$t_s = -\tau \ln \left[1 - \frac{\theta_{\max} - \theta_i}{\theta_s - \theta_i} \right]$$

where

$$\theta_i = (\theta_{\max} - 40 \text{ °C})(I_i/I_r)^{1.8} + \theta_a$$

and

$$\theta_s = (\theta_{\max} - 40 \text{ °C})(I_s/I_r)^{1.8} + \theta_a$$

For the special case where the initial current is 0, the equations in this form are useful. By substitution and further manipulation, the equations given above in terms of Y are obtained; these equations are convenient to use in the more usual case where the initial current is not 0.

5.4.4 Emergency load current carrying capability

During emergency periods, operation may be required at higher load currents than permitted by the ambient compensation procedure outlined in 5.4.3. Under these conditions, all the general considerations for ambient compensation are applicable to emergency loading with additional considerations and limitations as outlined in this subclause.

The limits of total temperature for the circuit breaker will be exceeded under the specified emergency load currents, and these higher temperatures may cause a reduction in the operating life of the circuit breaker. Inspection and maintenance of the circuit breaker are required following each emergency cycle as outlined in 5.4.4.5.

5.4.4.1 Conditions for emergency load current carrying capability

- a) Emergency load current carrying capability factors can only be applied to outdoor circuit breakers, as listed in IEEE Std C37.06-1997.

These factors can be applied to circuit breakers used in gas-insulated substations until specific standards for that equipment are issued.

Circuit breakers used in metal-clad switchgear shall be coordinated with overall application limitations of the total switchgear. Load current carrying capability under various conditions of ambient temperature and load for these circuit breakers is covered in IEEE Std C37.20.2-1993.

- b) Prior to the application of the emergency load, the circuit breaker current-carrying circuit, including external connections, shall have been well maintained and be in an essentially new condition.
- c) Following the emergency period, the load current shall be limited to 95% of I_a , the rated continuous current as modified by ambient compensation according to 5.4.3, for a minimum of 2 h.
- d) During and following an emergency cycle and prior to maintenance, the circuit breaker shall be capable of one interruption at its rated short-circuit current.
- e) Circuit breakers operated at temperatures that exceed their limits of total temperature may experience a reduction in operating life. Mandatory inspection and maintenance procedures are required following this duty in accordance with 5.4.4.5 and as recommended by the manufacturer.

NOTE—The thermal capability of associated equipment, such as cables, reactors, line traps, disconnecting switches, and current transformers, also shall be suitable for emergency loading. These pieces of equipment may limit the emergency rating to less than that calculated for the circuit breaker.

5.4.4.2 Emergency load current carrying capability factors for 4 h and 8 h

Emergency load current carrying capability factors with ambient temperature at 40 °C are listed in Table 5a for each limiting temperature of various circuit breaker components.

The factors have been selected to allow operation at 15 °C above the limits of total temperature for an emergency period of 4 h, or 10 °C above for an emergency period of 8 h. The factors are expressed as the ratio of emergency load current I_e allowed at an ambient temperature of 40 °C to the rated continuous currents I_r and can be applied with the following restrictions:

- a) The circuit breaker component with the highest values of limiting temperatures, θ_{\max} and θ_r , shall be used to select the proper emergency load current carrying capability factor from Table 5a.

NOTE—Circuit breakers with contacts and conducting joints in other than oil or air may be operated at higher temperatures than listed in IEEE Std C37.04-1999, Table 1, if it can be shown that accelerated deterioration will not occur. Unless rated otherwise by the manufacturer, contacts and conducting joints in other than oil or air are assumed to have the temperature limitations of silver, silver alloy, or equivalent materials in air (65 °C hottest-spot temperature rise, 105 °C hottest-spot total temperature).

- b) The 4 h factor shall be used for a cycle of operation consisting of separate periods of not longer than 4 h each, with not more than four such occurrences before maintenance.
- c) The 8 h factor shall be used for a cycle of operation consisting of separate periods of not longer than 8 h each, with not more than two such occurrences before maintenance.

- d) Each cycle of operation is separate, and no time-current integration is permissible to increase the number of periods within a given cycle. However, any combination of separate 4 h and 8 h emergency periods may be used. However, when they total 16 h, the circuit breaker shall be inspected and maintained according to 5.4.4.5 before being subjected to additional emergency cycles.

**Table 5a—Emergency load current carrying capability factors (I_e/I_r)
(Based on an ambient temperature of 40 °C)**

Emergency period	Limiting temperature (°C) of different breaker components							
	θ_{\max}	70	80	85	90	105	110	150
	θ_r	30	40	45	50	65	70	110
4 h		1.25	1.19	1.17	1.15	1.12	1.11	1.08
8 h		1.17	1.13	1.11	1.10	1.08	1.07	1.05

NOTE—For limiting current, use highest θ_r and θ_{\max} .

5.4.4.3 Emergency operation at an ambient temperature other than 40 °C

When a circuit breaker is operating at an ambient temperature other than 40 °C, the emergency load current carrying capability I_{ea} can be calculated by the following equation:

$$I_{ea} = I_r \left[\left(\frac{I_a}{I_r} \right)^{1.8} + \left(\frac{I_e}{I_r} \right)^{1.8} - 1 \right]^{1/1.8}$$

where

- I_{ea} is emergency load current at actual ambient temperature (A),
- I_r is rated continuous current (A),
- I_e is emergency load current at 40 °C ambient temperature (A),
- I_a/I_r is ambient compensation factor from Table 3 or calculated according to 5.4.3.2,
- I_e/I_r is emergency load current carrying capability factor from Table 5a.

The ratio of (I_{ea}/I_r) shall not exceed the value of 2.0. Calculated values of the ratio (I_{ea}/I_r) over a range of typical ambient temperatures are shown in Table 5b for a 4 h emergency period and in Table 5c for an 8 h emergency period. If the calculation does not provide the emergency current desired, then a circuit breaker with the next higher continuous current rating should be selected.

Table 5b—Emergency load current-carrying capability factors (I_{ea}/I_r) for various ambient temperatures for 4 h emergency period

Maximum ambient temperature (°C)	Limiting temperature (°C) of different breaker components							
	θ_{max}	70	80	85	90	105	110	150
	θ_r	30	40	45	50	65	70	110
60		0.90	0.92	0.93	0.93	0.95	0.95	0.98
50		1.08	1.06	1.06	1.04	1.04	1.03	1.03
40		1.25	1.19	1.17	1.15	1.12	1.11	1.08
30		1.40	1.30	1.27	1.24	1.19	1.17	1.13
25		1.47	1.36	1.32	1.29	1.23	1.21	1.16
20		1.53	1.41	1.37	1.33	1.27	1.25	1.17
10		1.66	1.51	1.46	1.41	1.33	1.31	1.21
0		1.78	1.61	1.55	1.50	1.40	1.38	1.26
-10		1.89	1.70	1.64	1.57	1.47	1.43	1.30
-20		2.00	1.79	1.72	1.65	1.52	1.50	1.35
-30		2.00	1.88	1.80	1.72	1.59	1.54	1.38

NOTES:

- 1—For limiting current, where the factor is 1.0 or greater, use highest θ_r and θ_{max} .
- 2—For limiting current, where the factor is less than 1.0, use lowest θ_r and θ_{max} .

Table 5c—Emergency load current-carrying capability factors (I_{ea}/I_r) for various ambient temperatures for 8 h emergency period

Maximum ambient temperature (°C)	Limiting temperature (°C) of different breaker components							
	θ_{max}	70	80	85	90	105	110	150
	θ_r	30	40	45	50	65	70	110
60		0.79	0.85	0.86	0.87	0.90	0.90	0.94
50		0.99	1.00	0.99	0.99	1.00	0.99	1.00
40		1.17	1.13	1.11	1.10	1.08	1.07	1.05
30		1.32	1.25	1.21	1.19	1.16	1.14	1.10
25		1.40	1.30	1.27	1.24	1.19	1.17	1.13
20		1.46	1.36	1.31	1.29	1.23	1.21	1.15
10		1.60	1.46	1.41	1.37	1.30	1.28	1.19
0		1.72	1.56	1.50	1.46	1.37	1.35	1.23
-10		1.83	1.65	1.59	1.54	1.43	1.40	1.27
-20		1.95	1.75	1.68	1.61	1.51	1.46	1.32
-30		2.00	1.84	1.75	1.68	1.56	1.51	1.36

NOTES:

- 1—For limiting current, where the factor is 1.0 or greater, use highest θ_r and θ_{max} .
- 2—For limiting current, where the factor is less than 1.0, use lowest θ_r and θ_{max} .

5.4.4.4 Short-time emergency load currents

A circuit breaker can be subjected to currents higher than the 4 h emergency load current I_{ea} if all the following conditions are satisfied:

- Prior to the application of a short-time emergency load current, the breaker shall be carrying a current not greater than I_a , the allowable continuous load current at actual ambient temperature.
- The duration of the short-time emergency load current shall be limited to a time that will not result in any breaker component exceeding by more than 15 °C the limits of total temperature specified in IEEE Std C37.04-1999. The allowable time can be determined by the method outlined in Figure 1.

In making this calculation, the 4 h emergency rating should be substituted for I_a . Under no condition shall the time exceed 4 h.

5.4.4.4.1 Emergency overload less than 4 h

For emergency overload less than 4 h, the allowable short time can also be computed using the formulas in 5.4.3.3.2. By substituting θ_{\max_s} (maximum allowable short-time emergency total temperature) for θ_{\max} in

$$t_s = -\tau \ln \left\{ 1 - \frac{\theta_{\max_s} - \theta_i}{\theta_s - \theta_i} \right\}$$

The θ_{\max_r} in the next two equations should be the rated maximum allowable total temperatures.

$$\theta_i = (\theta_{\max_r} - 40^\circ\text{C}) \left(\frac{I_i}{I_r} \right)^{1.8} + \theta_a$$

$$\theta_s = (\theta_{\max_r} - 40^\circ\text{C}) \left(\frac{I_s}{I_r} \right)^{1.8} + \theta_a$$

5.4.4.4.2 Computing allowable time of emergency overload less than 4 h

Given I_s , compute θ_s and t_s from the above equations.

Given t_s , compute θ_s from

$$\theta_s = \left(\frac{\theta_{\max_s} - \theta_i}{1 - \frac{1}{e^{t_s/\tau}}} \right) + \theta_i$$

and compute I_s from

$$I_s = I_r \left(\frac{\theta_s - \theta_a}{\theta_{\max_r} - 40^\circ\text{C}} \right)^{1/1.8}$$

Examples:

For breaker:

$$\tau = 0.5$$

$$\theta_r = 105 \text{ }^\circ\text{C}$$

$$\theta_{\max_s} = 120 \text{ }^\circ\text{C}$$

$$t_s = -0.51n \left(1 - \frac{120 - \theta_i}{\theta_s - \theta_i} \right)$$

$$\theta_s = \left(\frac{120 - \theta_i}{1 - \frac{1}{e^{t_s/0.5}}} \right) + \theta_i$$

$$\theta_i = (65) \left(\frac{I_i}{I_r} \right)^{1.8} + \theta_a$$

$$\theta_s = (65) \left(\frac{I_s}{I_r} \right)^{1.8} + \theta_a$$

$$\frac{I_s}{I_r} = \left(\frac{\theta_s - \theta_a}{65} \right)^{1/1.8}$$

For short-time overloads at rated temperature and current:

$$I_i = I_r \quad \theta_i = \theta_r \quad \theta_a = 40 \text{ }^\circ\text{C}$$

$$\theta_a = \left(\frac{120 - 105}{1 - \frac{1}{e^{t_s/\tau}}} \right) + 105$$

and

$$\frac{I_s}{I_r} = \left(\frac{\theta_s - 40}{65} \right)^{1/1.8}$$

t_s (h)	θ_s °C	I_s/I_r
3	120.04	1.122
2	120.28	1.124
1	122.34	1.140
0.5	128.73	1.189
0.25	143.12	1.292

For short-time overloads at rated temperature initial current 50% rated:

$$\theta_a = 40$$

$$\frac{I_i}{I_r} = 0.5$$

$$\theta_i = 65(.5)^{1.8} + 40$$

$$\theta_i = 58.67$$

t_s (h)	θ_s °C	I_s/I_r
3	120.15	1.123
2	121.14	1.131
1	129.60	1.190
0.5	155.60	1.370
0.25	214.54	1.730

- c) Each isolated application of short-time emergency load current shall be considered equal to one 4 h emergency period. However, a short-time emergency rating can be used in conjunction with a 4 h rating if the total time does not exceed 4 h.
- d) Following the application of a short-time emergency load current, the current shall be reduced to a level not exceeding the 4 h emergency load current I_{ea} for the remainder of the 4 h period, or if an isolated application, to not more than 95% of I_a for a minimum of 2 h.

5.4.4.5 Inspection and maintenance after an emergency cycle of operation

After each cycle of operation in which any combination of short-time 4 h and 8 h emergency periods is equivalent to 16 h, the circuit breaker shall be inspected. All required maintenance shall be accomplished in accordance with the manufacturer's recommendations before the circuit breaker is subjected to additional emergency cycles. The more important items to be checked are

- Primary current path resistance—which shall not exceed the manufacturer's service limits.
- Insulation power factor—a test on the circuit-breaker insulation system should show no significant increase over the pre-emergency load value.
- Gaskets, O-rings, and similar components used to seal various parts—these components should show no deterioration.

If, during the inspection and maintenance, changes are noted in any of the three areas, the manufacturer should be consulted before returning the circuit breaker to operation. If no differences are found, the emergency cycle can be repeated.

5.5 Rated dielectric withstand

5.5.1 Power frequency withstand voltage

The 1 min power frequency of circuit breakers is specified in rating tables in IEEE Std C37.06-1997 for various breakers ratings. This test provides a margin for normal deterioration, for minor contamination, and for normal voltage surges encountered in service. These apply to new circuit breakers tested at the factory. Tests after delivery are normally limited to 75% of factory values.

In some types of circuit breakers, dielectric withstand voltage may be reduced below a safe value by loss of vacuum, air, or gas pressure caused by a stuck valve or other malfunctioning device. Automatic isolation of the breaker should be considered in such cases. Where possible, the automatic isolation must be completed before the dielectric withstand of the circuit breaker is reduced so far that dielectric failure may occur from the transient overvoltage produced by the isolating device. When slow operating disconnect switches (either air switches or GIS switches) are used, restrikes are almost certain, and overvoltages in the 2.5-per-unit range are possible.

5.5.2 Lightning impulse withstand voltage

The basic lightning impulse insulation levels (BIL) of circuit breakers are specified in rating tables in IEEE Std C37.06-1997 for various breaker ratings. In applying circuit breakers, it is necessary to make certain that the insulation levels of all facilities at a terminal are properly coordinated. The application of gapped silicon carbide and metal oxide surge arresters is covered in IEEE Std C62.2-1994 and IEEE Std C62.22-1991, respectively. Since this is a matter of system insulation coordination, it is outside the scope of an application guide for circuit breakers.

When surge arresters are installed on the bus or on transformers and not on each circuit breaker, the surge voltage at the breaker can exceed that at the arresters. The amount of the excess depends upon the steepness of the wave front and the distance from the circuit breaker to the surge arresters. When the circuit breaker is in the open position, either intentionally left open or during operation, an incoming surge voltage may be doubled by reflection at the open contacts. Selection of too low an insulation level for circuit breakers, if not individually protected by arresters, may result in line-to-ground, or open gap dielectric failure of the circuit breaker. Use of individual line entrance surge arresters may be required if the lightning trip-out rate of the line exceeds 1 per year or any value acceptable to the user.

5.5.3 Switching impulse withstand voltage

This test requirement applies to circuit breakers having maximum design voltages 362 kV and above. New circuit breakers must withstand the crest voltage of a standard $250 \times 2500 \mu\text{s}$ impulse wave, when tested wet or dry. This test demonstrates that the circuit breaker insulation can withstand switching transients occurring under open-circuit, loaded, or faulted conditions. Test values are specified in the rating tables of IEEE Std C37.06-1997.

5.6 Standard operating duty

Power circuit breakers are rated for current interrupting ability on the basis of a standard operating duty (see IEEE Std C37.04-1999).

If the actual duty cycle application is different from the standard operating duty, refer to 5.9.

5.7 Interrupting time

The rated interrupting time of a circuit breaker is the maximum permissible interval between the energization of the trip circuit at rated control voltage and rated mechanism pressure and the interruption of the current in the main circuit in all poles. It is used to classify breakers of different speeds.

The rated interrupting time may be exceeded for close-open operations. The increase in interrupting time on close-open operation may be important from the standpoint of possible system instability. For low values of current, these considerations are less important.

At duties below 25% of the required interrupting capability at rated maximum voltage, the time required for interruption for oil and air magnetic breakers may be greater than the interrupting time by as much as 50% for 5-cycle and 8-cycle breakers, and 1 cycle for breakers of 3 cycles or less.

The rated interrupting times of specific circuit breaker ratings are given in the tables of IEEE Std C37.06-1997. Short interrupting times may be significant where system stability is critical. Application considerations including required margins should be incorporated in determining expected clearing time.

For line-to-ground faults, the interrupting time is estimated to exceed the rated interrupting time by 0.1 cycle. For asymmetrical faults, it is estimated that the interrupting time may exceed rated time by an additional 0.2 cycle. Hence, for grounded asymmetrical faults, the last phase to clear is estimated to be 0.3 cycle slower than the rated interrupting time. Additionally, rated interrupting time may be exceeded during extreme cold weather (see 4.2.1) or when the breaker has been closed for an extended period of time. Also, the breaker may be slower at the lower limits of control voltage and/or mechanism stored energy. These longer interrupting times are in the range of several milliseconds and may have system stability implications.

Figure 2 shows the sequence of events in the course of a circuit interruption and reclosure.

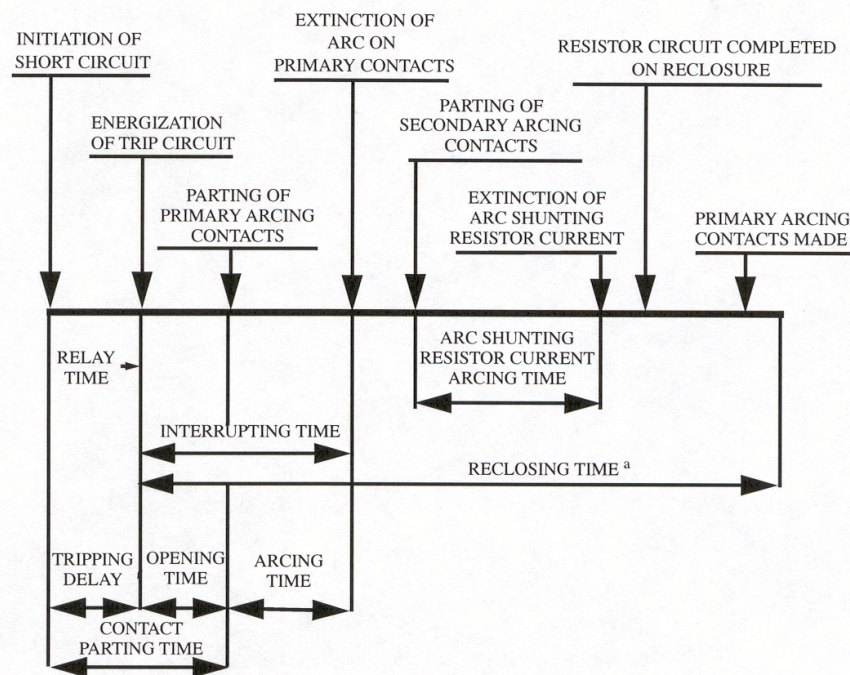

^aReclosing time is the time interval between energizing the trip circuit and making the primary arcing contacts. Where low ohmic resistors are used, making the resistor contact on reclosure may be more significant.

Figure 2—Operating time

5.8 Permissible tripping delay T (determined by short-time current test duration)

The rated permissible tripping delay Y IEEE Std C37.06-1997 constitutes a thermal limit, which should not exceed short-time current test duration.

5.8.1 Permissible tripping delay T

Tripping of the circuit breaker may be delayed beyond Y s values of current lower than rated short-time current, in accordance with the following formula:

$$T = Y \left[\frac{\text{(Rated short-circuit current)}}{\text{Short-circuit current through breaker}} \right]^2$$

The short-circuit current I through the circuit breaker equals the value of the current over the delay period T and is expressed by

$$I = \sqrt{\frac{1}{T} \int_0^T i^2 dt}$$

where

- i is instantaneous root mean square (rms) current (A),
- t is time (s).

To find the permissible tripping delay T , combine the above two equations, giving

$$\sqrt{\frac{1}{Y} \int_0^T i^2 dt} = \text{(Rated short-circuit current)}, \text{ or}$$

$$\int_0^T i^2 dt = Y(\text{Rated short-circuit current})^2$$

Determine the envelope of the short-circuit current through the breaker, against time, and obtain the rms values from IEEE Std C37.09-1999.

Square the latter values and obtain the corresponding curve. Integrate this ($i^2 dt$) for various values of delay periods T (see IEEE Std C37.09-1999). The value of T for which the integral equals Y times rated short-circuit current squared is the permissible tripping delay.

Example: Consider an outdoor circuit breaker having a rated short-circuit current of 22 000 A. Assume the short circuit current I is 20 000 A and Y is 2 s. Then the permissible tripping delay is

$$T = 2 \left(\frac{22\,000}{20\,000} \right)^2 = 2.42 \text{ s}$$

This limit applies to short-circuit current and does not apply to load current, motor-starting current, or similar service. The aggregate tripping delay on all operations within any 30 min period must not exceed the time obtained from the above formula.

5.9 Reclosing time

High-speed reclosing may be applied on radial lines to minimize the effect of line outages. In most cases, reclosing within 0.5 s from incidence of a fault will prevent any adverse effect of the circuit outage on residential and commercial customers. In many cases, industrial customers can modify their equipment to eliminate most of the adverse effects of momentary outages if high-speed reclosing is employed.

High-speed reclosing has been used successfully on tie lines where opening a circuit separates a portion of the system from the remainder. In this case, it is necessary to reclose before magnitude of the phase angle of voltages across the open circuit has reached a value beyond the capability of the circuit to restore synchronism following reclosure. In many applications on loop and grid systems, high-speed reclosing is used to prevent instability, to improve voltage conditions, and to minimize the effects of line outages.

Several definitions of dead time for a circuit breaker are given in IEEE Std C37.100-1992. Before a circuit can be successfully re-energized, there must be sufficient dead time in the circuit breaker for the arc path at the fault to become deionized. On a radial line where the load includes a large motor component, arcing may be sustained after the breaker at the source is opened. Synchronous motors and static capacitors included in the load will tend to prolong the period of arcing. On tie lines, dead time on the circuit is the time interval between interruption of current by the last circuit breaker to clear and making of the contacts on the first breaker to reclose.

A dead time on the circuit of at least 135 ms is normally required to clear the fault's ionized gases at 115 kV to 138 kV for breakers without resistors across the interrupters. The required dead time is greater for higher voltages or when selective pole tripping is used to clear only the faulted phases. Dead times on the order of several seconds may be required to allow secondary arcs to extinguish. (Secondary arcs result from capacitive coupling between the normal and faulted phases.)

5.9.1 Reclosing interrupting capability derating

The rated interrupting capabilities of oil circuit breakers and air magnetic circuit breakers need to be derated for reclosing.

Whenever an oil or air magnetic circuit breaker is applied on a duty cycle other than the standard duty cycle, as defined in IEEE Std C37.04-1999, its rated short circuit current and related required capabilities shall be modified by the reclosing capability factor R to enable the circuit breaker to meet its standard of interrupting performance as defined in 5.10.

Interrupting capability factors for reclosing service apply to all oil and air magnetic circuit breakers as shown in IEEE Std C37.06-1997 that are

- Rated 100 kV and above, regardless of continuous current rating.
- Rated below 100 kV and having continuous current ratings at 1200 A and below. Breakers with continuous current ratings above 1200 A are not intended for reclosing service applications. When such applications arise, the manufacturer should be consulted for capability factors.

Modifications of rated interrupting capability are required for duty cycles with these characteristics:

- For each operation in excess of 2.
- In addition, for each reclosure that is made in a period of time less than 15 s down to an instantaneous reclosure. Interpolation shall be used to determine the value of the capability factor for reclosing times between 0 s and 15 s. Fifteen seconds means any period 15 s or longer. Zero seconds means any instantaneous reclosure with no intentional delay.

Circuit breakers manufactured prior to IEEE Std C37.7-1960 have different basis of derating. The reclosing capability factor R that applies to oil and air magnetic circuit breakers is determined as follows:

$$R = 100 - D \text{ (percent)}$$

and

$$D = d_1(n - 2) + d_1 \frac{(15 - t_1)}{15} + d_1 \frac{(15 - t_2)}{15} + \dots$$

where

- D is total reduction factor (%),
- d_1 is calculating factor for D of breaker symmetrical interrupting capability at operating voltage, from Figure 3a (%),
- n is total number of openings,
- t_1 is first time interval less than 15 s,
- t_2 is second time interval less than 15 s,
- t_3 is

Then

$$I_D = (I_R) (R)$$

where

- I_D is modified symmetrical interrupting capability of the circuit breaker,
- I_R is rated symmetrical short circuit current.

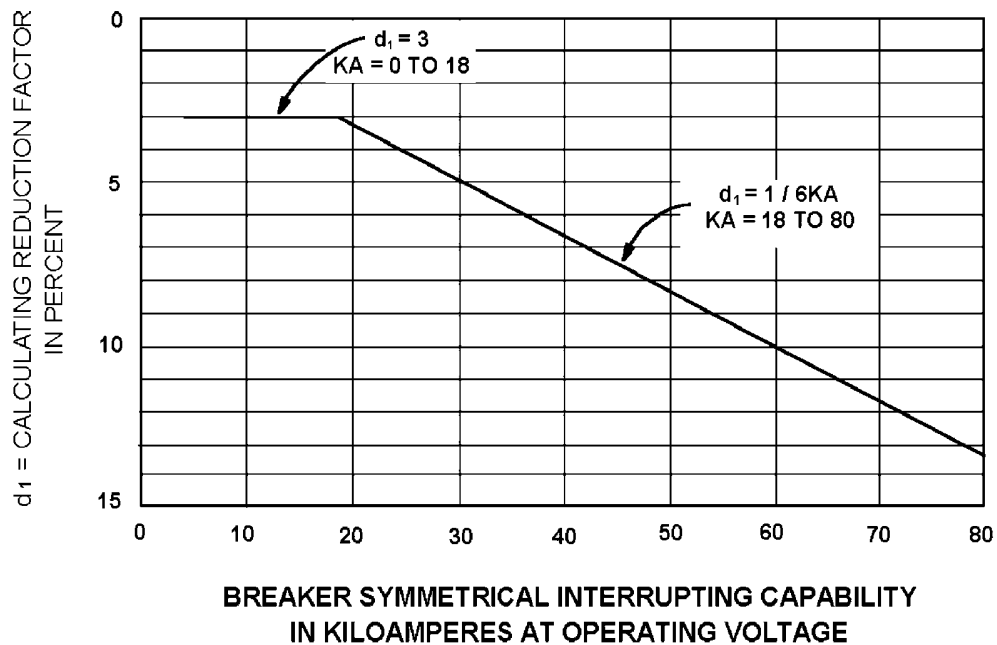

Figure 3a—Interrupting capability factor for reclosing service

Other related required capabilities may be determined by multiplying this value by the factors established in IEEE Std C37.04-1999.

Interrupting capability factors determined in this manner are subject to these conditions:

- A duty cycle shall not contain more than five opening operations.
- All operations within a 15 min period are considered part of the same duty cycle.
- A period of 15 min between opening operations is considered sufficient to initiate a new duty cycle.

Figure 2 illustrates the reclosing time, which is defined in IEEE Std C37.100-1992. Figure 3b gives factors to be applied to the interrupting capabilities of circuit breakers where derating is required for reclosing duty cycles other than the standard operating duty. Only oil and air magnetic circuit breakers require derating. Examples of the use of these factors follow.

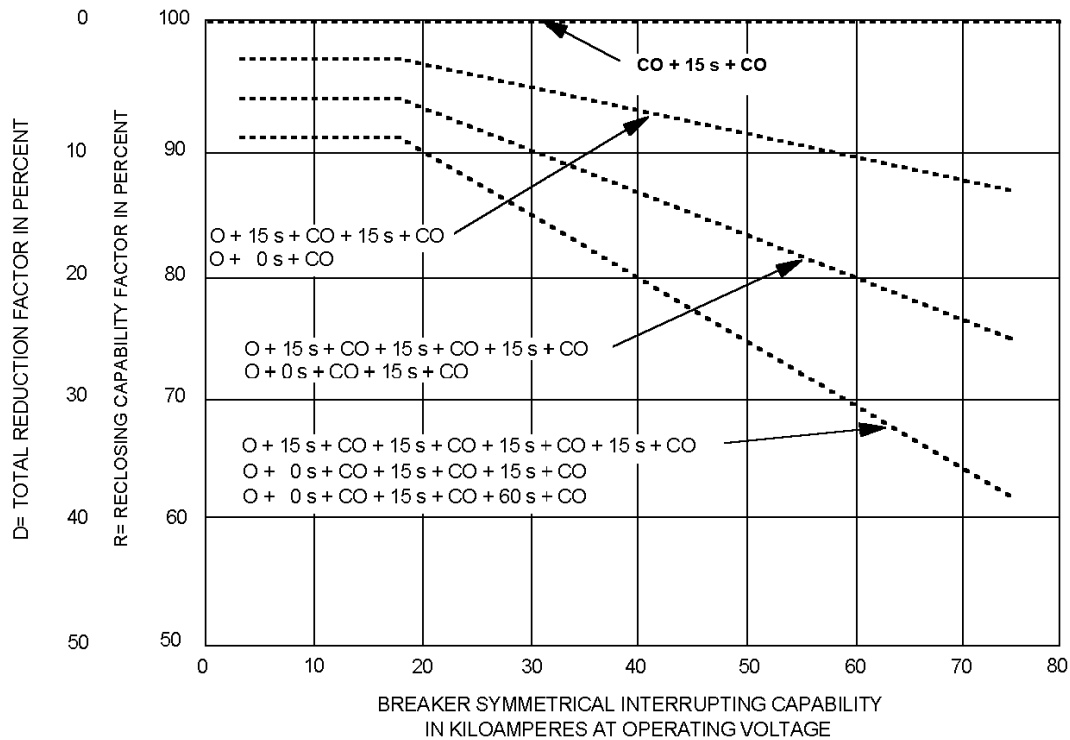

Figure 3b—Examples of reclosing capability for some usual reclosing duty cycles

Example 1: Determine the symmetrical interrupting capability of an outdoor oil circuit breaker when used on a duty cycle of O + 0 s + CO + 15 s + CO + 60 s + CO on a system operating at 23 kV. The breaker rated short-circuit current is 22 000 A at a rated maximum voltage of 38 kV on a duty cycle of CO + 15 s + CO. The rated voltage range factor is 1.65.

- 1) The symmetrical interrupting capability at 23 kV is $22\,000\text{ A} \times (38/23)$ or $22\,000\text{ A} \times 1.65 = 36\,300\text{ A}$.
- 2) The calculating reduction factor d_1 for reducing the symmetrical interrupting capability is 6.0 at 36 300 A.
- 3) The total reduction factor D is 10

$$D = 6(4 - 2) + 6\left[\frac{(15 - 0)}{15}\right] + 6\left[\frac{(15 - 15)}{15}\right] + 0 = 18\%$$

The reclosing capability factor is

$$R = 100 - 18 = 82.0\%$$

- 4) The symmetrical interrupting capability for this duty cycle at 23 kV is

$$36\,300\text{ A} \times 0.82 = 29\,800\text{ A}$$

- 5) This circuit breaker may be used on this duty cycle at 23 kV on any circuit where the calculated system short-circuit current does not exceed 29 800 A after correction for X/R , if necessary, as explained in Annex A or as in 6.3.2.

Example 2: Determine the symmetrical interrupting capability of a circuit breaker when used on a duty cycle $O + 0\text{ s} + CO + 5\text{ s} + CO$ on a system operating at 28 kV. The breaker rated short circuit is 22 000 A at a rated maximum voltage of 38 kV on a duty cycle of $CO + 15\text{ s} + CO$.

- 1) The symmetrical interrupting capability at 28 kV is $22\,000\text{ A} \times (38/28) = 29\,900\text{ A}$.
- 2) The calculating factor d , from the reclosing capability curve in Figure 3a is 4.9 at 29 900.
- 3) The total reduction factor using the formula for this duty cycle is,

where

- d_1 is 4.9,
- n is 3,
- t_1 is 0,
- t_2 is 5.11

$$D = 4.9(3 - 2) + 4.9\frac{(15 - 0)}{15} + 4.9\frac{15 - 5}{15} = 13.1$$

$$R = 100 - 13.1 = 86.9$$

- 4) The symmetrical interrupting capability = $29\,900\text{ A} \times 0.869 = 26\,000\text{ A}$ at 28 kV and the above duty cycle.
- 5) This breaker may be used on this duty cycle at 28 kV on any circuit where the calculated system short-circuit current does not exceed 26 000 A, after correction for X/R , if necessary, as explained in Annex A or in 6.3.2.

Examples of other reclosing capabilities for some reclosing duty cycles are shown graphically in Figure 3b.

NOTE—For circuit breakers with a voltage range factor K of 1.0, the symmetrical interrupting capability, when applied at or below the rated maximum voltage, will not change. For example, a circuit breaker with a rated symmetrical short circuit current of 22 000 A at a rated maximum voltage of 38 kV on a duty cycle of $CO + 15\text{ s} + CO$ with a voltage range factor K of 1.0 will interrupt a 22 000 A symmetrical fault when applied at 38 kV. If this circuit breaker is applied at 23 kV, it can still only interrupt a 22 000 A symmetrical fault.

5.10 Short-circuit current rating

In the application of circuit breakers, it is necessary that none of the short-circuit current capabilities of a circuit breaker be exceeded. These capabilities are derived from rated short-circuit current and are described in IEEE Std C37.04-1999.

5.10.1 Symmetrical interrupting capability

The maximum symmetrical interrupting capability that a circuit breaker is required to have is K times the rated short-circuit current. While most modern circuit breakers have a K of 1.0 (see 5.2), some older breakers have a value of K greater than 1.0. For these circuit breakers, the symmetrical interrupting capability between rated maximum voltage and $1/K$ times the rated maximum voltage is defined as

$$\text{Rated short-circuit current} \times \left(\frac{\text{Rated maximum voltage}}{\text{Operating voltage}} \right)$$

except that, for line-to-ground faults, the required symmetrical interrupting capability is 15% higher but in no case greater than K times the rated short-circuit current. For additional information refer to IEEE Std C37.010-1979.

5.10.2 Asymmetrical requirements

A circuit breaker having adequate symmetrical interrupting capability will have adequate capability to meet all of the related short-circuit requirements unless there is a significant contribution from motor load or the X/R ratio is greater than approximately 17 (dc time constant greater than 45 ms).

The circuit breaker is required to interrupt an asymmetrical current defined by the dc component given in Figure 4. If the actual contact parting time of the breaker including 0.5-cycle relay time is less than the assumed value (e.g., 1.5 cycle for a 2-cycle breaker, 2 cycles for a 3-cycle breaker, 3 cycles for a 5-cycle breaker, and 3.5 cycles for an 8-cycle breaker), the breaker is required to have a total interrupting capability corresponding to the actual minimum contact parting time in accordance with IEEE Std C37.04-1999. Five-cycle rated vacuum and SF₆ circuit breakers used at voltages up to 38 kV often have contact part times of 2.0 cycles or less.

If the actual relay time is less than 0.5 cycles (8.3 ms), however, this fact should be taken into consideration when calculating the required asymmetrical capability and thus the required symmetrical current rating of the circuit breaker. Delayed current zeros may be a problem with some breakers.

5.10.2.1 Motor contribution

Significant motor loads can cause the asymmetrical short-circuit current at 0.5 cycle of fault initiation to be increased to a greater degree proportionately than the symmetrical current will be increased at contact parting time. Refer to Note 4 of 6.4.1 for the treatment of the motor contribution where it affects the initial asymmetrical current. Methods of allowing for slow decrement of the asymmetrical current are discussed in 6.3.

5.10.2.2 Higher system X/R ratios (dc time constants greater than 45 ms)

With X/R ratios greater than 17 at 60 Hz, the decrement rate for the dc component will be slower than that incorporated in the rating structure (see Figure 1 of IEEE Std C37.04-1999). With air, oil, vacuum, and certain SF₆ breakers, the effect of these higher X/R ratios can be accommodated by the methods of 6.3.2.

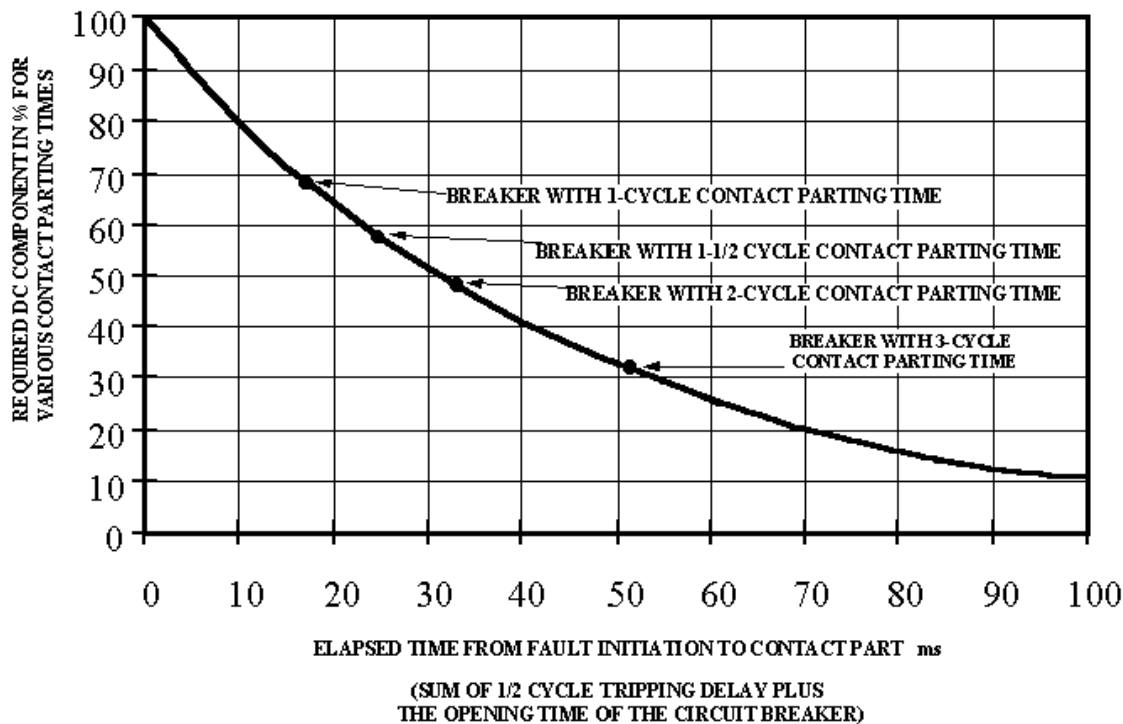

Figure 4—Power circuit breaker design requirements

The longer dc time constants could cause a problem for some types of SF₆ puffer breakers. The interrupting window, which is the time difference between the minimum and maximum arcing times, of these breakers may be exceeded because of delayed current zeros (for example, the puffer type interrupter may “cease its puffing action” before a current zero arrives). Both arc energy and interruption window may be of concern. This subject is currently under study. Consensus is that in cases where the short-circuit current requirement is lower than the rated short-circuit current by at least one class within the R10 series (i.e., required short-circuit current is less than 80% of rating), a circuit breaker tested with a time constant of 45 ms may fulfill the requirement for any higher time constant (except in cases as mentioned in 5.10.2.3 where current zeros are absent for several cycles). For duties above 80%, the derating method of 6.3.2 can be used provided that the X/R ratio does not exceed 45 at 60 Hz (dc time constant not to exceed 120 ms). For time constant beyond 120 ms, consult the manufacturer.

5.10.2.3 Generator buses

In some applications, particularly on generator buses, a condition may occur where asymmetry is over 100% Owen [B7]. Where this condition exists, precautions should be taken to protect breakers against opening where normal current zeros are not obtained. The precautions include

- Extended relay times
- Circuit breaker location to avoid this objectionable degree of asymmetry

5.11 Transient recovery voltage

For transient recovery voltage (TRV), see IEEE Std C37.011-1994; and for fast TRVs associated with transformers or reactors, see IEEE Std C37.06.1-1997.

5.12 Load current switching capability and life (repetitive operation)

Careful attention must be given to the limits given in IEEE Std C37.06-1997.

Motor starting duty may require closing the circuit breaker against inrush currents many times greater than the running current. This will not be limiting on a circuit breaker having a continuous current rating at least equal to the maximum running current of the motor. During motors switching, overvoltages may be generated; thus overvoltage protection and/or R-C snubber circuits should be considered.

Special circuit breakers may be required for applications involving highly repetitive operations, such as arc furnace switching and plugging, jogging, or reversing motors.

5.13 Capacitance current switching

For capacitance current switching, see IEEE Std C37.012-1979.

5.14 Line closing (line-closing switching surge factor)

When a circuit breaker is closed to energize an overhead transmission line, it produces a transient overvoltage on the power system, the peak of which is called the line-closing switching surge maximum voltage. Circuit breakers that have been specifically designed to control such voltage to be less than a specified limit are assigned a rating called the rated line-closing switching surge factor. This rating designates that the circuit breaker is capable of controlling line-closing switching surge voltages, so that there is a probability of at least 98% of not exceeding the rated line-closing switching surge factor when switching the standard reference transmission line from the standard reference power source.

Establishment of the rated line-closing switching surge factor is based on closing the circuit breaker governed by random time energization of the device, which initiates closing of all three phases.

Random closing of the circuit breaker will produce line-closing switching surge maximum voltages that vary in magnitude according to the instantaneous value of the source voltage, the parameters of the connected system, and the time differences between completion of the circuit path in each phase. These variations will be governed by the laws of probability so that the highest and the lowest possible overvoltages will occur very infrequently. In recognition of this and of the economy associated with not designing for the worst case, the rated line-closing switching surge factor is based on the probability that the circuit breaker will produce a line-closing switching surge factor equal to, or less than, the rated factor 98% or more of the times it is closed and never more than 1.2 times the rated factor.

5.14.1 Statistical analysis of the number of allowable occurrences in excess of the rated value

Any device with which there is a mathematically constant probability of 2% of the occurrence of an event will usually show different test results than exactly one event in a series of 50 tests. In the present case, if the event is defined as the line-closing switching surge factor's exceeding the rated factor and a large number of test series consisting of 50 tests each were conducted, in 36.4% of the repeated test series, the rated factor would not be exceeded; in 37.1% of the series, the rated value would be exceeded once; in 18.6%, twice; in 6.1%, 3 times; in 1.5%, 4 times; and in 0.3%, 5 times (from the binomial formula). Thus a circuit breaker with a perfectly maintained and constant 2% probability of exceeding the rated switching surge factor would do so four or more times in about 2% of repeated test series of 50 tests each.

It is expected that the rated switching surge factor of a circuit breaker design will be based on a great number of tests made by the manufacturer on a simulated system. If the manufacturer is required by a user to perform

a witnessed design test, it shall be done in accordance with IEEE Std C37.09-1999, which allows 2% of the tests to have a line-closing switching surge factor in excess of the rated factor. The probability of obtaining a set of 50 tests with no more than one excessive occurrence is 73.5% as determined from the binomial formula. A substantial probability (26.5%) exists, therefore, that additional sets of 50 tests each will be required. The nature of the simulated tests allows such repeated tests to be made with a minimum of time and expense. If the design is proper and enough tests are made, the ratio of voltage exceptions to total number of tests will attain 2% or less.

If a user performs a conformance field test on an operating system, it is expected that the normal operating requirements of the system will place a severe limitation on the number of tests allowable. The sequential method of performing the conformance test allows the capability of the circuit breaker to be determined within known statistical limits in a minimum number of tests. The sequential test method has been designed partly in accordance with the method outlined in Sonnenberg [B36] and Wald [B39]. In the terminology of these references, the specified parameters are as follow:

- P_1 = 2.3% (–2 sigma) probability of exceeding rated factor for acceptable circuit breaker
- P_2 = 15.9% (–1 sigma) probability of exceeding rated factor for unacceptable circuit breaker
- Alpha = 5% = probability of false rejection
- Beta = 5% = probability of false acceptance

The sequential test series as specified in IEEE Std C37.09-1999 contains approximately equal 5% risks (Alpha and Beta) that

- A circuit breaker with an actual probability of 2.3% of exceeding the rated factor will be falsely rejected
- A circuit breaker with an actual probability of 15.9% of exceeding the rated factor will be falsely accepted.

5.14.2 Type of power system to which the rated line-closing switching surge factor applies

The rated line-closing switching surge factor applies to a power system where the circuit breaker connects an overhead transmission line directly to a power source of 362 kV and above. The factor applies specifically to a power system with characteristics of the standard reference power system as described in IEEE Std C37.09-1999 and also to those actual power systems whose characteristics are not greatly different from those of the standard reference power system.

The transmission line is open at the receiving end and is not connected to such terminal apparatus as a power transformer although it may be connected to an open circuit breaker or disconnect switch.

The system does not include shunt reactors, potential transformers, series capacitors, shunt capacitors, surge arresters, or any similar apparatus unless specified in IEEE Std C37.06-1997.

It is anticipated that any actual power system that deviates too greatly from the standard reference power system may require that a simulated study be made of it in order to determine the actual line-closing switching surge factor to be expected.

5.15 Conditions of use with respect to the out-of-phase switching current rating

The conditions of use with respect to the out-of-phase switching current rating are as follows:

- Opening and closing operations carried out in conformity with the instructions given by the manufacturer for the operation and proper use of the circuit breaker and its auxiliary equipment; closing operations should be limited to a maximum out-of-phase angle of 90° whenever possible (see Note 2 below).

- Grounding condition of the neutral of the power system corresponding to that for which the circuit breaker has been tested.
- Frequency within $\pm 20\%$ of the rated frequency of the circuit breaker.
- Absence of a fault on either side of the circuit breaker.
- Protection from unsynchronized source voltage fluctuations that vary up to 2 times rated voltage.

NOTES

1—All circuit breakers having an assigned out-of-phase switching current rating are able to perform the duties specified in IEEE Std C37.09-1999.

2—The requirements of this standard cover the great majority of applications of circuit breakers intended for switching during out-of-phase conditions. Several circumstances would have to be combined to produce a severity in excess of those covered by the tests of this standard and, as switching during out-of-phase conditions is rare, it would be uneconomical to design circuit breakers for the most extreme conditions.

Where frequent out-of-phase switching operations are anticipated or where for other reasons out-of-phase switching is a matter of importance, the user should consider actual system recovery voltages. A special circuit breaker, or one rated at a higher voltage, may sometimes be required. As an alternative solution, the severity of out-of-phase switching duty is reduced in several systems by using relays with coordinated impedance-sensitive elements to control the tripping instant, so that interruption will occur either substantially after or substantially before the instant the phase angle is 180° .

5.16 Shunt reactor current switching

For shunt reactor current switching, see IEEE Std C37.015-1993.

5.17 Transformer current switching

Circuit breakers used for switching exciting current and certain transformer connected load currents including energizing and de-energizing of feeder regulators and transformers may require special consideration due to switching frequency or severity.

5.17.1 Special consideration for switching transformers

Transformers often have high internal winding “ringing” frequencies. Certain switching operations may excite these frequencies so that voltage escalation can result deep in the transformer winding creating excessive intra-winding stress. Traditional surge arresters applied at the terminal of the transformer or circuit breaker have been shown to be ineffective to stop this phenomenon. Resistance and capacitance “snubber” networks connected across the transformer winding have been shown to be effective. A snubber is a circuit element, usually consisting of a capacitor connected in series with a resistor connected phase to ground at the transformer terminals, to limit the rate of rise of voltage or the peak voltage.

NOTE—Power systems, transformers and circuit breakers form a dynamic system during switching operations. On rare occasions this interaction requires action to mitigate the transient frequencies produced during switching.

Circuit breaker operations impose frequencies on transformers that may resonate with or in power system elements. Transformers can experience mid-winding overvoltages from circuit breaker operation and from many other power system conditions. Resolution of these problems can be difficult and may require participation by the power system, transformer, and circuit breaker designers.

5.18 Mechanical endurance

Circuit breakers are designed to operate satisfactorily for the number of operations specified in IEEE Std C37.06-1997.

5.19 Rated control voltage

The successful performance of circuit breakers depends upon maintenance of control voltage within the standard limits as shown in IEEE Std C37.06-1997. The voltage at the control terminals of the circuit breaker should be approximately the rated control voltage and must not be less than the minimum specified in IEEE Std C37.06-1997, under loaded conditions even under minimum expected battery voltage conditions.

Batteries, battery chargers, control transformers, etc., should be selected considering this limit and taking into account the line drop encountered in the control buses, leads, relay series coils, the condition and charge of the battery, and the volt-ampere burden on the control transformers. The possibility of simultaneous closing and tripping of two or more power circuit breakers should be considered in selecting the control power supply. Control current on trip-free operation may be quite high. These items are especially critical where lower control voltages (24–48 V) are used.

Where emergency service, communication loads, indicating lights, or similar power requirements must be supplied from a control battery, these represent a sustained load requirement for the battery and charger and should be included in selecting the size of equipment.

5.20 Fluid operating pressure

Circuit breakers operated by fluid pressure are designed to operate over a pressure range prescribed by the manufacturer. Limit switches to control compressor or pump operation, to indicate low pressure, and to prevent circuit breaker operation below minimum pressure are normally provided. A suitable power source for compressor or pump operation is required.

5.21 Insulating oil for circuit breaker

For instruction on testing, maintaining, and accepting insulating oil to be used in circuit breakers, see IEEE Std C57.106-1991.

5.22 Closed pressure system (gas-filled)

All gas-filled circuit breakers will have some leak over their lifetime. Circuit breakers require that the correct gas filling level, pressure, or density be maintained over their expected life.

6. Short-circuit considerations

6.1 System short-circuit currents

One of the most important requirements of circuit breaker application is the determination of the maximum short-circuit duty imposed on the breaker.

Different methods of determining system short-circuit currents have been published. In general, more complex calculations give improved accuracy. The application engineer should select the method in accordance with the required accuracy. Ordinarily, the methods of 6.3.1 and 6.3.2 will be conservative.

6.1.1 Short-circuit tests

The most accurate determination of short-circuit current may be made by adequately controlled and instrumented staged fault tests. Sometimes such tests are made to test new equipment or system arrangements,

but are not generally practical as a means of determining required capability of circuit breakers on a power system since, in most cases, selection of circuit breakers precedes completion of new facilities.

6.1.2 Types and severity of system short circuits

A three-phase power system is subjected to the following types of faults:

- Three-phase ungrounded fault
- Three-phase grounded fault
- Phase-to-phase ungrounded fault
- Phase-to-phase grounded fault
- Phase-to-ground fault

In general, the three-phase ungrounded fault imposes the most severe duty on a circuit breaker since the first phase to interrupt has a power frequency recovery voltage of approximately 87% of system phase-to-phase voltage. (The corresponding value for a three-phase grounded fault is 58% when $X_0 = X_1$ and up to 75% on an effectively grounded system.) (See IEEE Std 32-1972.)

A phase-to-ground fault may produce a higher fault current than a three-phase fault. This condition exists where the zero-sequence reactance at the point of fault is less than the positive-sequence reactance ($X_0 < X_1$). This will not necessarily result in a higher current through the breaker as positive and zero-sequence currents may flow in opposite directions.

6.1.3 Short-circuit current characteristics

It must be assumed that a short circuit on any ac system can produce the maximum offset (dc component) of the current wave. The resulting asymmetrical current wave decays gradually to a symmetrical current. The rate of decay of the dc component is determined based upon L/R time constant of 45 ms, which is equivalent to a X_L/R ratio of 17 at 60 Hz and X_L/R ratio of 14 at 50 Hz. The time constant for dc component decay is

$$T_{dc} = \text{Circuit } L/R \text{ in seconds} = \frac{\text{Circuit } X/R}{2\pi f \text{ (Hz)}}$$

$$\text{Required dc component in \% of ac component} = e^{-\frac{\text{Contact part time}}{T_{dc}}} \times 100$$

$$I_{dc} \text{ Component} = \%dc X \sqrt{2} I_{sym}$$

The total rms fault current is obtained by the formula

$$\text{Total rms current} = \sqrt{(I_{sym})^2 + (I_{dc} \text{ component})^2}$$

Circuit breakers are designed to interrupt satisfactorily with the required dc component of fault current shown in Figure 4. When a breaker interrupts a short-circuit current, the critical current value is that existing at the time of primary arcing contact parting. The curve of Figure 4 is designed to specify the required asymmetrical capability (component of fault current) of any circuit breaker based on the elapsed time from fault initiation to contact part time (assume 0.5-cycle [8.33 ms based on 60 Hz] minimum relay time plus the circuit breaker opening time). For example, assume a circuit breaker has an opening time of 1.5 cycles and a minimum contact parting time of 2 cycles. From Figure 4, the circuit breaker has a required dc component capability of 48% at 2 cycles based on 60 Hz.

The more exact type of calculation (see 6.3.2) evaluates the decay in the ac and dc components of the short-circuit current. When the fault is close, electrically, to a major element of generation, the ac decay will be appreciable during the first few cycles.

The ac decay may not be significant in system locations that are electrically remote from generation. This may be so even in auxiliary systems fed directly from the generator terminals, but through a relatively high impedance reactor or transformer.

In cases where high X/R ratios are encountered and some tripping delay in excess of 0.5 cycle is used, advantage may be taken of the system decay in either or both of the dc and ac components of short-circuit current.

In locations where such advantage is taken of the decay in the ac and dc components, special care must be exercised to assure that the circuit breaker capability at 0.5 cycle (closing and latching capability) is not exceeded. This peak current capability is 2.60 times rated rms symmetrical short-circuit current.

Also, in the presence of motor load, closing on a short circuit may be critical, in which case the critical current may be that of the first major current peak. Proper provision for this condition is assured by making a closing and latching duty calculation using the rotating machine reactances indicated in 6.4.1.

In any case, neither the required symmetrical nor the required asymmetrical interrupting current capability of a circuit breaker should be exceeded at the time of primary arcing contact separation.

6.2 Selection of applicable circuit breaker ratings

With the short-circuit current duties at the circuit breaker location available (see 6.3), the most severe of these should be used in selecting the desired breaker rating from the tables of preferred ratings in IEEE Std C37.06-1997. The proper table for indoor or outdoor breaker types should be chosen. One or more interrupting and continuous ampere ratings are available in most voltage classes.

6.3 Methods for calculating system short-circuit currents

Various methods and devices are in use for the calculation of short-circuit current. Rather rigorous methods involving step-by-step application of ac and dc decrements have been devised and used for faults at generating stations. These same methods are sometimes used for faults at other locations, but the application of the methods is more difficult and less satisfactory as the impedance networks became more complex.

A simplified method is described in 6.3.1. This method requires only an E/X calculation.

A more accurate method is described in 6.3.2. This method gives results approximating those obtained by more rigorous methods. In using it, it is necessary first to make an E/X current calculation. Then it is necessary to adjust the E/X current value for both the ac and dc decay, which depends upon the circuit conditions. This method also provides for the possibility of including both ac and dc decays where relay time delay in excess of the 0.5-cycle minimum is utilized. This method should provide results having an accuracy commensurate with the usually available short-circuit characteristics of electrical equipment and systems.

In instances where using impedances is desired instead of reactances for determining short-circuit current magnitudes, E/Z may be substituted for E/X in the descriptions that follow.

6.3.1 E/X simplified method

In many cases of short-circuit current calculations a simple E/X computation (E/X_1 for three-phase faults or $3E/(2X_1 + X_0)$ for single line-to-ground faults) will provide adequate accuracy for circuit breaker application.

NOTE—See 6.4 for definitions of electrical quantities.

The results of the E/X simplified procedure may be compared with 100% of the circuit breaker symmetrical interrupting capability where it is known that the system X/R ratio (X_1/R_1) for three-phase faults or $(2X_1 + X_0)/(2R_1 + R_0)$ for single line-to-line ground faults is 17 or less at 60 Hz.

NOTE—For simplification, negative-sequence reactance X_2 is assumed equal to positive-sequence reactance X_1 . A similar assumption is made for resistance values R_2 and R_1 .

The E/X simplified procedure may be used without determining the system R if E/X for three-phase fault does not exceed 80% of the symmetrical interrupting capability of the breaker. This corresponds to applying the circuit breaker one step down on the R_{10} series below its rating. If using a breaker is desired where the current determined in this case exceeds 80% of the breaker's symmetrical interrupting capability, a more exact method of calculation such as described in 6.3.2 should be used to check the adequacy of the circuit breaker taking into account the dc time constant.

The more exact procedure should also be used if $3E/(2X_1 + X_0)$ for single line-to-ground faults, exceeds 70% of the circuit breaker symmetrical interrupting capability for single line-to-ground faults (see 6.3.2).

Example of E/X simplified method:

- 1) *General.* Consider the system shown in Figure 5.

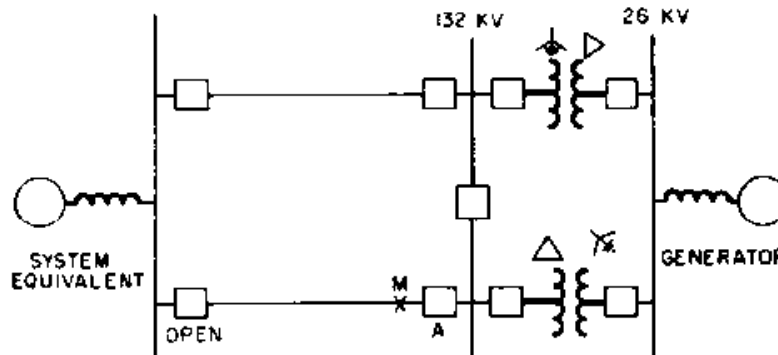

Figure 5—System illustrating use of simplified method of short-circuit calculation

Faults on both sides of breaker A in Figure 5 and of all other circuit breakers should be considered, assuming in each case that the breaker in question is the last breaker to clear the fault. However, upon careful observation of the system involved, it may be apparent that a fault on one side of the breaker gives a higher fault current than does a fault on the other side. Such is the case for breaker A in the system shown in Figure 5. Therefore, currents have been calculated for a fault on only one side at position M. However, in case of doubt, fault currents for faults on both sides of the breaker should be calculated. For single line-to-ground faults on tie lines, the condition with the remote breaker closed may sometimes produce a fault current through the breaker higher than that occurring when the remote breaker is open. In such a case, the single line-to-ground fault current will not exceed the three-phase fault, except for an unusual combination of impedances.

- 2) *Three-phase fault calculations.* In the system shown in Figure 6, per-unit reactances are indicated adjacent to generators, transformers, and lines. Apparent power is 100 MVA base. Nominal voltage is used as base at all levels.

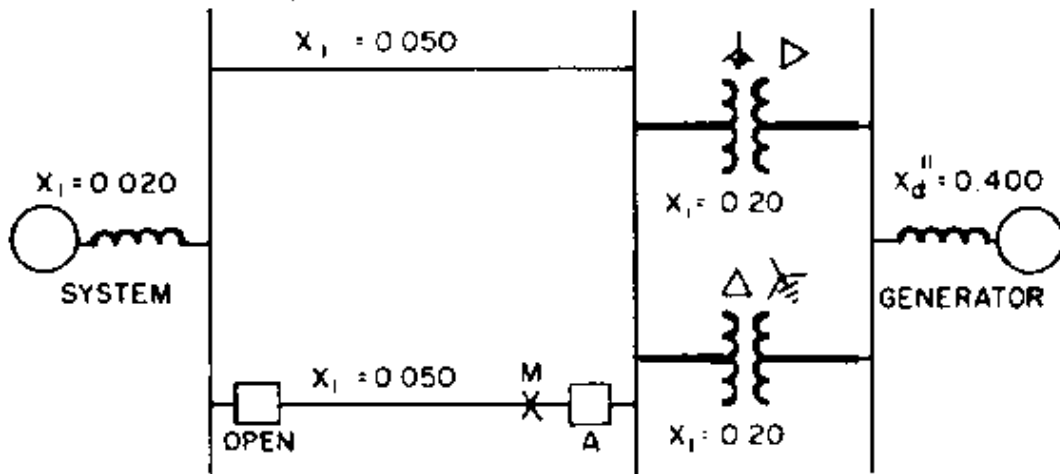

Figure 6—Positive-sequence reactances for system shown in Figure 5

$$\text{Total } X_1 = \frac{(0.050 + 0.020)\left(0.400 + \frac{0.200}{2}\right)}{(0.050 + 0.020) + \left(0.400 + \frac{0.200}{2}\right)} = \frac{0.070 \times 0.50}{0.070 + 0.50} = 0.061$$

Base voltage = 132 kV

Base current = 437 A

The value of operating voltage corresponding to the highest typical operating voltage at the fault point is 134 kV or 1.015 per unit.

$$I_{sc} = \frac{1.015}{0.061} \times 437 = 7270 \text{ A}$$

- 3) *Single line-to-ground fault calculation.* Consider the system shown in Figure 7.

$$\text{Total } X_0 = \frac{(0.030 + 0.20)(0.20)}{(0.030 + 0.20) + 0.20} = 0.107$$

Since X_0 is greater than X_1 , the single line-to-ground fault need not be considered.

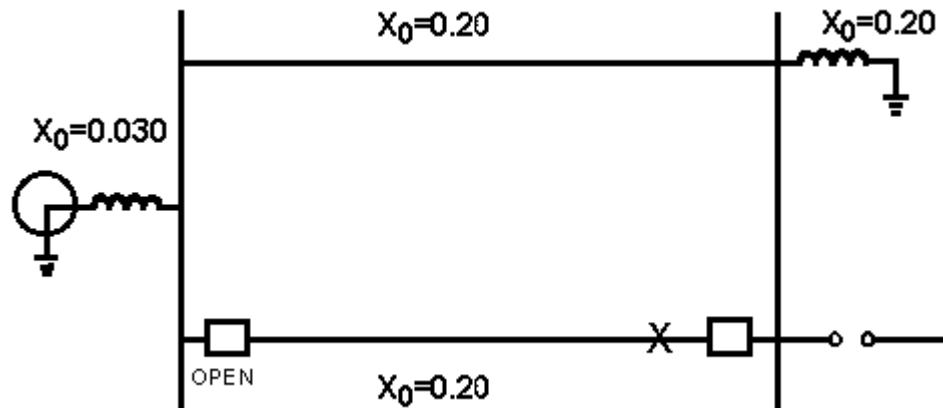

Figure 7—Zero-sequence reactance for system shown in Figure 5

- 4) *Selection of breaker.* A circuit breaker is to be selected from the preferred rating schedules in IEEE Std C37.06-1997. The load current requirement is 600 A and the standard duty cycle is used.

Consider a breaker that has a rated maximum voltage of 145 kV, a continuous current rating of 1200 A, a rated short-circuit current of 20 000 A at 145 kV, a maximum symmetrical interrupting capability of 20 000 A, and a voltage range factor K of 1.0. For a three-phase fault, the symmetrical interrupting capability of the breaker is 20 000 A at the 134 kV operating voltage.

Since the three-phase short-circuit current (7270 A) is less than 80% of the symmetrical interrupting capability (16 000 A), this breaker is adequate for the service required. A large margin for growth exists that may be important in selecting the breaker for a new application.

6.3.2 E/X method with adjustment for ac and dc decrements

For greater accuracy than given by the E/X simplified method described in 6.3.1, the procedure in this subclause should be used.

The technical basis for this procedure is presented in Annex A. The procedure involves steps for applying factors to the E/X calculation. These factors depend upon the point on the system at which the short circuit occurs and upon the system X/R ratio (or dc time constant) as seen from that point.

For determining the system X/R ratio, it should be noted that no completely accurate way exists of combining two parallel circuits with different values of X/R into a single circuit with one value of X/R . The current from the several circuits will be the sum of several exponentially decaying terms, usually with different exponents, while that from a single circuit contains just one such term. Investigation has shown that by reducing reactance to a single value with complete disregard for the resistances and reducing the resistance to a single value with complete disregard for the reactances gives, in general, more accurate results than any other reasonably simple procedure (including the phasor representation used at system frequency). In addition, the error for practical cases is on the conservative side. For these reasons, this procedure is recommended.

In cases where an E/Z calculation is made, substituting Z/R for X/R is acceptable provided that the R is obtained from a separate reduction of resistance disregarding reactances.

The factors taken from Figure 8, Figure 9, or Figure 10 should be applied to the E/X calculation so that ac and dc decrements are properly included in the final result.

The following procedure is usually conservative:

- a) The factors of Figure 8 and Figure 9 include the effects of both ac and dc decay. The E/X current should be multiplied by a factor from Figure 8 for a three-phase fault and by a factor from Figure 9 for a line-to-ground fault if the short-circuit current is fed predominantly from generators through a per-unit reactance external to the generator that is less than 1.5 times the generator per-unit subtransient reactance on a common system megavolt-ampere base.
- b) The factors of Figure 10 include only the effects of dc decay. The E/X current should be multiplied by a factor from Figure 10 for a three-phase or a line-to-ground fault if the short-circuit current is fed predominantly from generators through a per-unit reactance external to the generator that is equal to or exceeds 1.5 times the generator per-unit subtransient reactance on a common system megavolt-ampere base.

The resulting product must not exceed the symmetrical interrupting capability of the circuit breaker being considered.

The maximum correction factor obtained from Figure 8 in most practical applications is approximately 1.25. This 1.25 factor forms the basis for establishing 80% of circuit breaker capability as a limit for application of the simplified method in 6.3.1 for three-phase faults where X/R is unknown.

The maximum correction factor from Figure 9 is approximately 1.41. This factor forms the basis for establishing 70% of circuit breaker capability as a limit for application of the simplified method in 6.3.1 for line-to-ground faults where X/R is unknown. The maximum corrections of Figure 10 exceed these values, but since this figure is based on faults fairly far removed from the generator terminals ($X_{ext} > 1.5 X''_d$), it is highly unlikely that the X/R ratios would be such that the 1.25 and/or 1.41 factors would be exceeded.

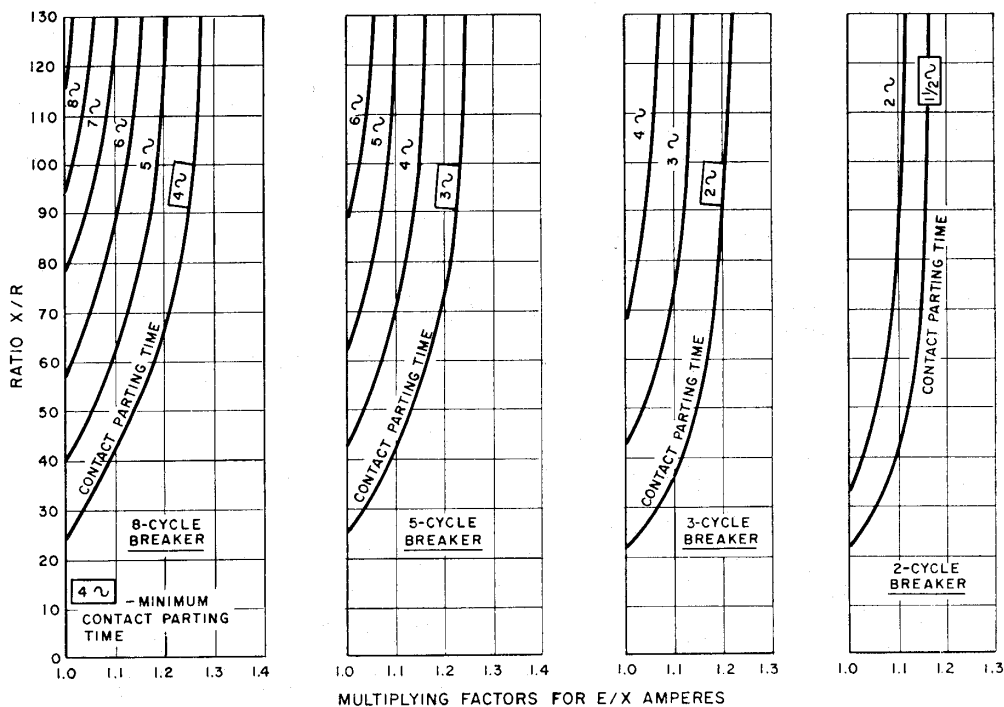

Figure 8—Three-phase fault multiplying factors that include effects of ac and dc decrement [see 6.3.2 a)]

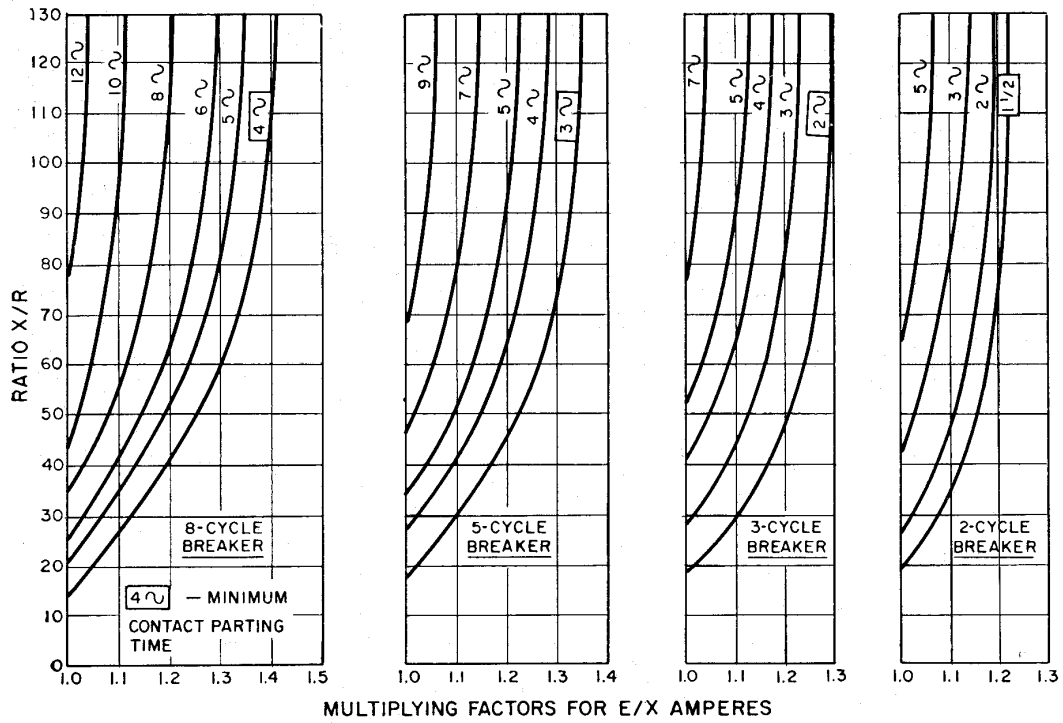

Figure 9—Line-to-ground fault multiplying factors that include effects of ac and dc decrement [see 6.3.2 a)]

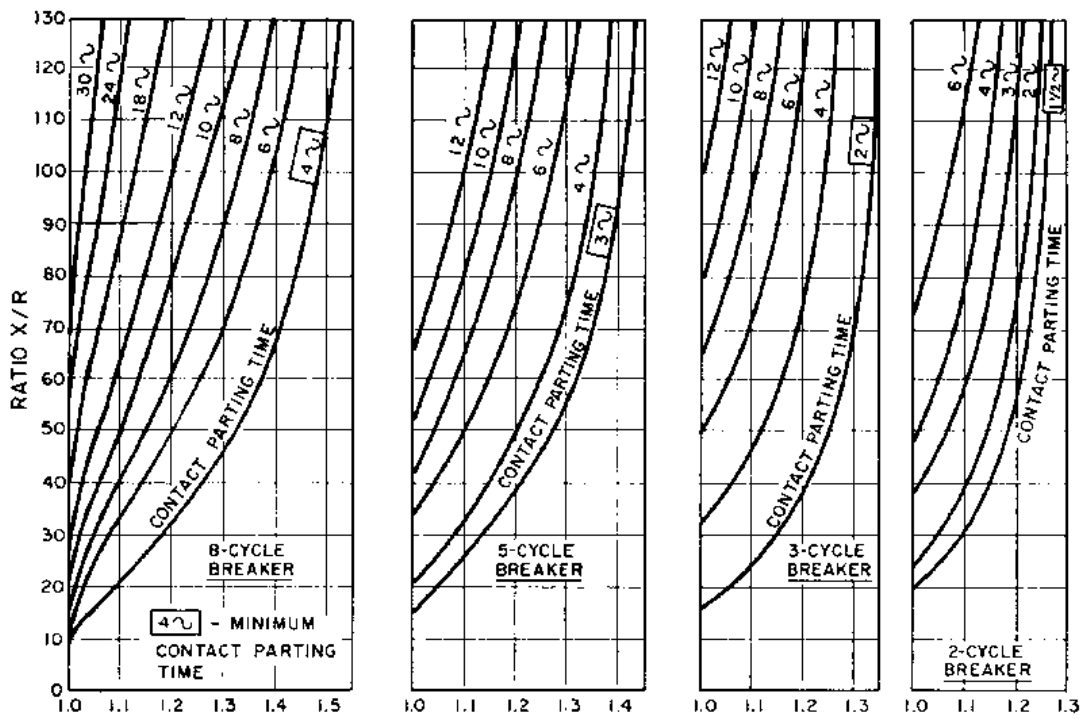

Figure 10—Three-phase and line-to-ground fault multiplying factors that include effects of dc decrement only [see 6.3.2 b)]

In breaker applications, relays slower than 0.5 cycle are sometimes used. In some cases, consideration could be given to utilize this relay time to reduce the fault current at contact parting time to avoid or postpone replacement of circuit breakers. Figures 8, 9, and 10 include curves for breakers of typical speeds for longer contact parting times to aid in checking the adequacy of circuit breakers with contact parting times longer than the normal minimum. The breakers must still meet the closing and latching duty.

Example of E/X method with adjustment for ac and dc decrements:

- 1) *General.* Consider the system shown in Figure 11.

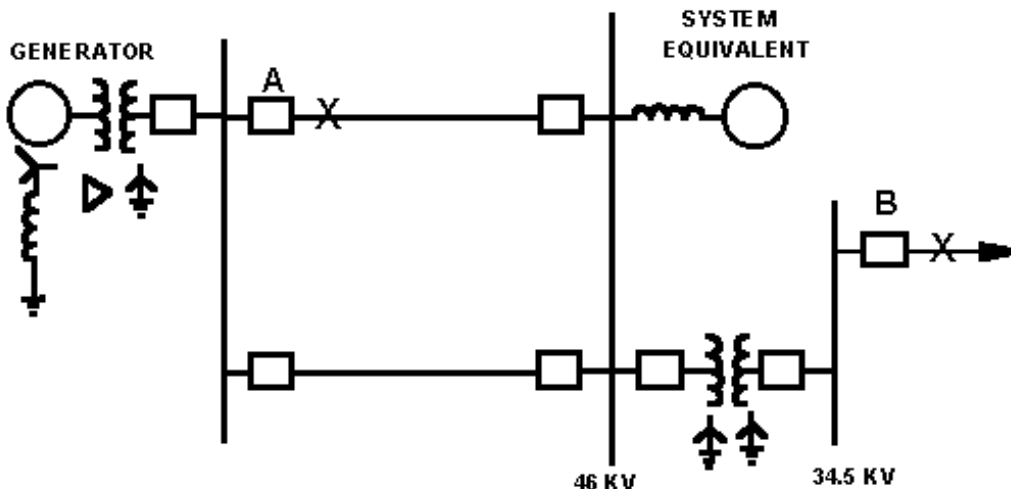

Figure 11—System illustrating use of E/X method with adjustment for ac and dc decrements

Since it is apparent that faults on the line side of breakers A and B produce higher fault current through the breaker than does a fault on the bus side, currents have been calculated on only one side of each breaker. In case of doubt, fault currents for faults on both sides of the breaker should be calculated.

- 2) *Three-phase fault calculation of breaker A (case 1).* In the system shown in Figure 12, per-unit reactances are indicated adjacent to generators, transformers, and lines. Base apparent power is 100 MVA. Nominal voltage is used as base at all levels.

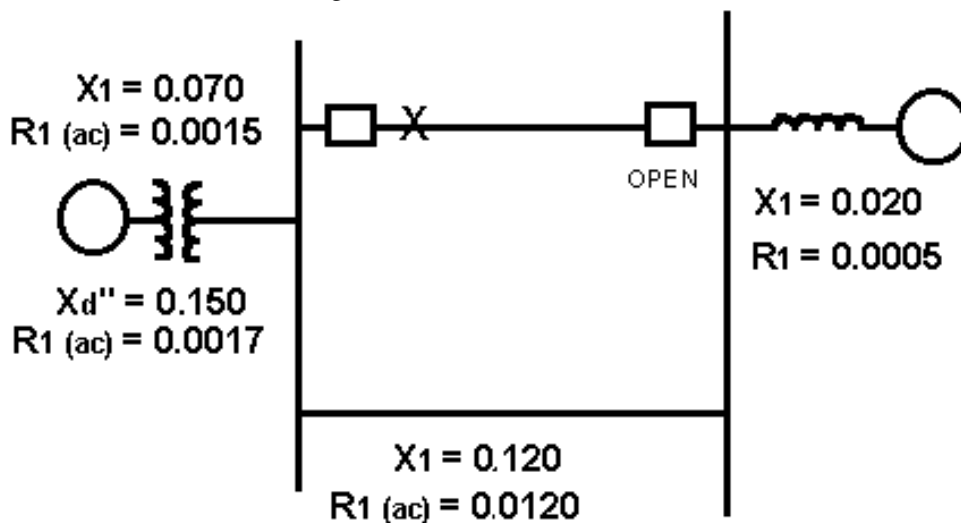

Figure 12—Positive-sequence impedance for system shown in Figure 11 (breaker A)

$$\text{Total } X_1 = \frac{(0.150 + 0.070)(0.020 + 0.120)}{(0.150 + 0.070 + 0.020 + 0.120)} = 0.0856$$

$$\text{Total } R_1 = \frac{(0.0017 + 0.0015) + (0.0005 + 0.0120)}{0.0017 + 0.0015 + 0.0005 + 0.0120} = 0.00255$$

Base voltage = 46 kV

Base current = 1255 A

The value of voltage corresponding to the highest typical operating voltage at the fault point is 46.8 kV line to line or 1.017 per unit.

$$I_{sc} = \frac{1.017}{0.0856} \times 1255 = (14\,910) \text{ A}$$

- 3) *Single line-to-ground fault calculation of breaker A (case 1).* Consider the system shown in Figure 13.

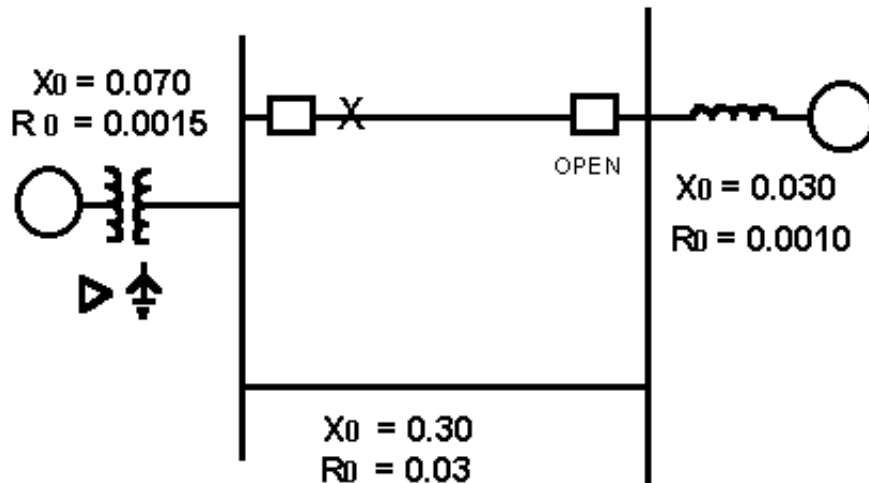

Figure 13—Zero-sequence impedance for system shown in Figure 11 (breaker A)

$$\text{Total } X_0 = \frac{(0.070)(0.030 + 0.300)}{(0.070 + 0.030 + 0.300)} = 0.0578$$

$$\text{Total } R_0 = \frac{(0.0015)(0.0010 + 0.0300)}{0.0015 + (0.0010 + 0.0300)} = 0.00143$$

$$I_{sc} = \frac{3 \times 1.017}{2(0.0856) + 0.0578} \times 1255 = 16\,720$$

- 4) *Factors applicable to E/X calculation for more accurate calculation (case 1).* For a three-phase fault,

$$\frac{X_1}{R_1} = \frac{0.0856}{0.00255} = 33.6$$

Consider a 38kV 5-cycle breaker with a contact parting time of 3 cycles, including relay time, and a normal duty cycle. Since the breaker is on the bulk system and has an external reactance less than 1.5 times the generator subtransient reactance and since the X/R ratio is greater than 15, the breaker duty should be multiplied by a factor from Figure 8 to assure conservative breaker application. This factor is 1.05. The current to be compared with the breaker symmetrical interrupting capability is $14\,910 \times 1.05 = 15\,660$ A. For a single line-to-ground fault,

$$\frac{2X_1 + X_0}{2R_1 + R_0} = \frac{2 \times 0.0856 + 0.0578}{2 \times 0.00255 + 0.00143} = 35.1$$

From Figure 9, the single line-to-ground short-circuit current should be multiplied by 1.13 to assure conservative breaker application. The current to be compared with the breaker symmetrical interrupting capability for single line-to-ground faults is $16\,720 \times 1.13 = 18\,890$ A.

- 5) *Selection of breaker (case 1).* A circuit breaker is to be selected from the preferred rating schedules of IEEE Std C37.06-1997. The load current requirement is 700 A, and the standard duty cycle is used.

Consider an outdoor circuit breaker with a rated maximum voltage of 48.3 kV, a continuous current rating of 1200 A, a rated short-circuit current of 20 000 A at 48.3 kV, and a voltage range factor K of 1.0. The symmetrical interrupting capability at 46.8 kV is 20 000 A since $K = 1.0$.

For a single line-to-ground fault, the symmetrical interrupting capability is found by multiplying the three-phase symmetrical interrupting capability by 1.15 (except that this result cannot exceed the maximum symmetrical interrupting capability of 20 000 A).

Therefore, for this case, the maximum line-to-ground fault capability is the same as the three-phase fault capability of 20 000 A.

In the investigation of an existing station, this breaker would be adequate. However, in designing a new station, more margin for growth may be desirable and the next larger breaker might be chosen. Table 6 shows comparison of calculated short-circuit current with the capability of a breaker.

NOTE— X may be either X_1 or $2X_1 + X_0$ and R may be either R_1 or $2R_1 + R_0$ as shown in 6.4.

Table 6—Calculated short-circuit current compared with breaker capability

Calculated short-circuit current				Symmetrical interrupting capability	
Fault	E/X	X/R factor	Adjusted E/X	At rated maximum voltage	At operating voltage
Three-phase	14 910	1.05	15 660	20 000	20 000
Single line-to-ground	16 720	1.13	18 890	20 000	20 000

- 6) *Three-phase fault calculation of breaker B (case 2).* Consider the system shown in Figure 14.

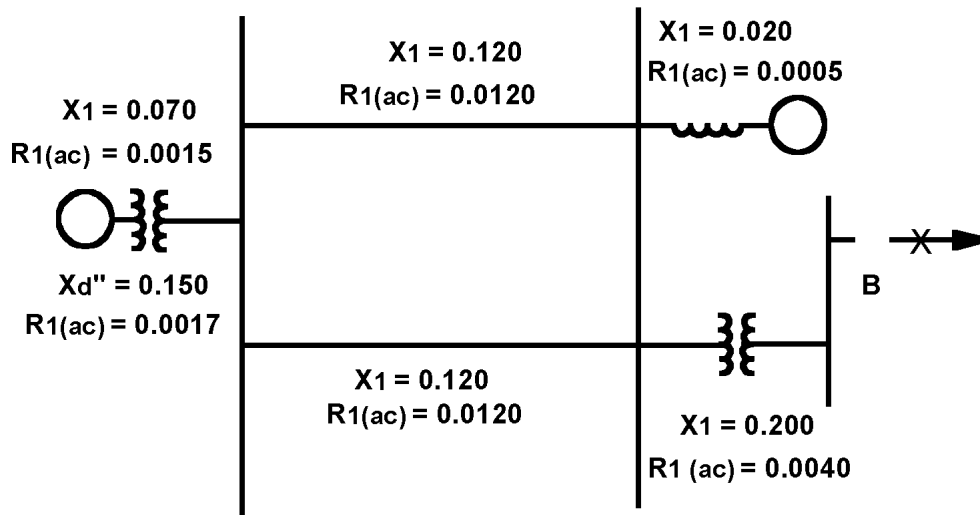

Figure 14—Positive sequence impedance for system shown in Figure 11 (breaker B)

$$X_1 = \frac{(0.150 + 0.070 + 0.120/2)(0.020)}{(0.150 + 0.070 + 0.120/2) + 0.020} + 0.200 = 0.219$$

$$R_1 = \frac{(0.0017 + 0.0015 + 0.0120/2)(0.0005)}{(0.0017 + (0.0015) + 0.0120/2) + 0.0005} + 0.0040 = 0.00447$$

Base voltage = 34.5 kV

Base current = 1670 A

The value of voltage corresponding to the highest typical operating voltage at the fault point is 34 kV or 0.986 per unit.

$$I_{sc} = \frac{0.986}{0.219} \times 1670 = 7520 \text{ A}$$

- 7) *Single line-to-ground fault calculation of breaker B (case 2).* Consider the system shown in Figure 15.

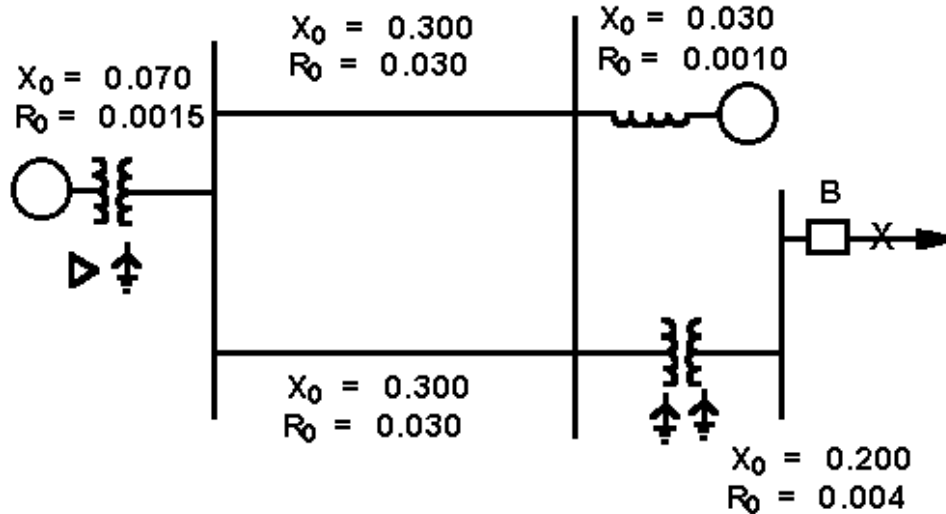

Figure 15—Zero-sequence impedance for system shown in Figure 11 (breaker B)

$$X_0 = \frac{\left(0.070 + \frac{0.300}{2}\right)(0.030)}{\left(0.070 + \frac{0.300}{2}\right) + 0.030} + 0.200 = 0.226$$

$$R_0 = \frac{\left(0.0015 + \frac{0.0300}{2}\right)(0.0010)}{\left(0.0015 + \frac{0.0300}{2}\right) + 0.0010} + 0.0040 = 0.0049$$

$$I_{sc} = \frac{0.986 \times 3}{(0.219 \times 2) + 0.226} \times 1670 = 7440 \text{ A}$$

- 8) *Factors applicable to E/X calculation for more accurate calculation (Case 2).* For a three-phase fault,

$$\frac{X_1}{R_1} = \frac{0.219}{0.00447} = 49.0$$

Consider a 38 kV 5-cycle breaker with a minimum relay time of 1.5 cycles resulting in a contact parting time of 4 cycles and a standard duty cycle. Since the breaker is on the distribution system, the external impedance is greater than 1.5 times the generator subtransient reactance, and the X/R ratio is greater than 17, the breaker duty should be multiplied by a factor from Figure 10 for a conservative breaker application. This factor is 1.20. The current to be compared with the breaker symmetrical interrupting capability is $1.20 \times 7520 = 9024$ A for a three-phase fault. For a single line-to-ground fault,

$$\frac{2X_1 + X_0}{2R_1 + R_0} = \frac{(2 \times 0.219) + 0.226}{(2 \times 0.00447) + 0.0049} = 48$$

From Figure 10, the single line-to-ground short-circuit current should also be multiplied by 1.19. The current to be compared with the breaker symmetrical interrupting capability for single line-to-ground faults is $1.19 \times 7440 = 8850$ A. A breaker would be selected as described in item 5) of 6.3.2.

6.4 Electrical quantities used

E is the line-to-neutral value corresponding to the highest typical operating voltage that occurs at the circuit breaker location.

X is the corresponding lowest value of system reactance (determined with R assumed 0) as viewed from the fault point, with all rotating machines represented by the appropriate reactances as specified in 6.4.1. It may be either X_1 or $2X_1 + X_0$ according to whether three-phase or single line-to-ground currents are being calculated.

- X_1 is the positive-sequence reactance (equivalent to X as used in this standard),
- X_2 is the negative-sequence reactance (in the simplified method of fault calculation, assumed equal to X_1),
- X_0 is the zero-sequence reactance that may be obtained from design data, by calculation, or by test,
- X''_d is the subtransient direct-axis reactance of a synchronous machine or locked-rotor reactance of an induction machine (always a positive-sequence reactance),
- X'_d is the transient direct-axis reactance of a synchronous machine (always a positive-sequence reactance),
- R is the corresponding lowest value of system resistance as viewed from the fault point (determined with X assumed 0) with the resistances of the system components determined as specified in 6.4.2 (Instead of calculating R_1 an estimate of the system X/R ratio may be determined as shown in Table 9. R may be either R_1 or $2R_1 + R_0$ depending on whether three-phase or single line-to-ground currents are being calculated.),
- R_1 is the positive-sequence resistance,
- R_2 is the negative-sequence resistance,
- R_0 is the zero-sequence resistance that may be obtained from design data, by calculation, or by test,
- L is inductance (H) [$L = X/2\pi f$ (where f is system frequency)],
- C is capacitance,
- Z is impedance,
- I is current,
- I_{sc} is the calculated symmetrical short-circuit current,
- K is the voltage range factor (see IEEE Std C37.04-1979 and IEEE Std C37.06-1987),
- T_{dc} is the direct-current time constant for the circuit involved in the short circuit being calculated (see 6.1.3).

NOTE—Load reactances are neglected in this guide since they are usually large with respect to the series reactance and have little effect on the magnitude of short-circuit current.

6.4.1 Rotating machine reactances

Basically, initial short-circuit current of rotating machines is determined by the machine subtransient reactances. For the simplified and more accurate methods of short-circuit current calculation, Table 7 shows the reactances that are used.

Table 7—Reactances

Type of rotating machine	Positive sequence reactances for calculating	
	Interrupting duty (per unit)	Closing and latching duty (per unit)
All turbo-generators, all hydro-generators with amortisseur windings, and all condensers ^a	$1.0 X''_d$	$1.0 X''_d$
Hydro-generators without amortisseur windings ^a	$0.75X'_d$	$0.75X'_d$
All synchronous motors ^{b,d,e}	$1.5 X''_d$	$1.0 X''_d$
Induction motors ^{c,d,e} Above 1000 hp at 1800 r/min or less Above 250 hp at 3,600 r/min	$1.5 X''_d$	$1.0 X''_d$
	From 50 hp to 1000 hp at 1800 r/min or less From 50 hp to 250 hp at 3,600 r/min	$3.0 X''_d$
Neglect all three-phase induction motors below 50 hp and all single-phase motors		

^a X''_d of synchronous rotating machines is the rated-voltage (saturated) direct-axis transient reactance.

^b X''_d of synchronous rotating machines is the rated-voltage (saturated) direct-axis subtransient reactance.

^c X''_d of induction motors equals 1.00 divided by per-unit locked-rotor current at rated voltage.

^dThe current contributed to a short circuit by induction motors and small synchronous motors may usually be ignored on utility systems, except station service supply systems and at substations supplying large industrial loads. At these locations, as well as in industrial distribution systems, locations close to large motors, or both, the current at 0.5 cycle will be increased by the motor contribution to a greater degree, proportionately, than the symmetrical current will be increased at minimum contact parting time. In these cases, an additional calculation of 0.5-cycle current should be made using the methods of 6.3.1 or 6.3.2 and the appropriate reactance values given in Table 7 under the heading “Closing and latching duty.” A 2.6 multiplying factor should be used for asymmetry, and this result must not exceed the closing and latching capability (in peak current) of the circuit breaker being used.

^eThese rotating machine reactance multipliers and the E/X amperes multipliers of Figure 8 and Figure 9 include the effects of ac decay. However, the methods for calculating system short-circuit current described in 6.3.1 and 6.3.2 incorporate sufficient conservatism to permit the simultaneous use of a rotating machine reactance and an E/X amperes multiplier from Figure 8 or Figure 9.

NOTE—When the contribution of large individual induction motors is an appreciable portion of the short-circuit current, substitution for the tabulated multiplying factors of more accurate multipliers based on manufacturer’s time constant data is appropriate. Using $I = (E/X''_d)e^{-t/T''}$ as the expression for the exponential decay of induction motor symmetrical current to a terminal short circuit, the reactance multiplying factor is $e^{+t/T''}$, where T is the proper time after initiation of the short circuit and T'' is the motor short-circuit time constant. (Both should be in the same time units.) For example, using manufacturer’s motor data for T'' , the reactance multiplying factor for determining the interrupting duty may be found using t equal to the circuit breaker minimum contact parting time. For a circuit breaker with a 5-cycle rated interrupting time, $t = 3$ cycles (0.05 s). For determining the closing and latching duty, $t = 0.5$ cycle (0.00833 s) in the reactance multiplying factor calculations.

Example: In the system shown in Figure 16, impedances are per unit on a 100 MVA base. Base current at 4.16 kV = 13 900 A.

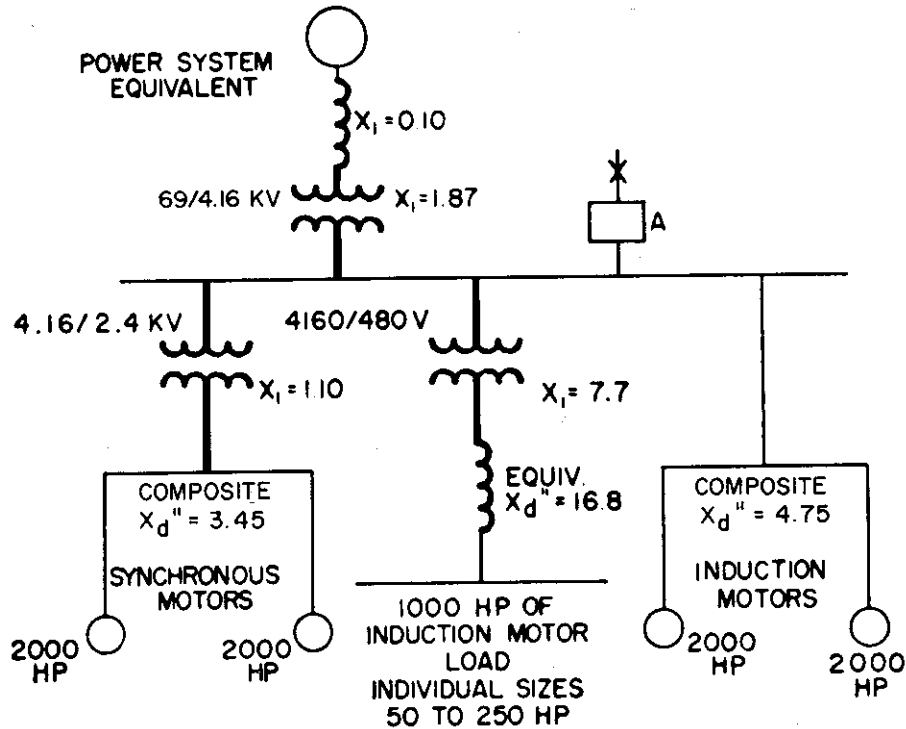

Figure 16—System illustrating large short-circuit contribution from motors

Per-unit reactances are indicated adjacent to generators and transformers. Nominal voltage is used as base at all positions. The value of voltage corresponding to the highest typical operating voltage at the fault point is 4.16 kV or 1.0 per unit. The X/R ratio is less than 15. Therefore, the correction factor based on X/R will be 1.0 (see 6.3.1).

Consider an indoor oilless circuit breaker with a rated maximum voltage of 15.0 kV, a voltage range factor K of 2.27, a continuous current rating of 1200 A, a rated short-circuit current of 9300 A, and a maximum symmetrical interrupting capability of 21 000 A at 6.6 kV and below. The symmetrical interrupting capability of this breaker at 4.16 kV is 21 000 A. The current to be compared with the symmetrical interrupting capability is for a three-phase fault near breaker A:

$$13\,900 \left[\frac{1}{1.87 + 0.10} + \frac{1}{(3.45)(1.5) + 1.10} + \frac{1}{(16.8)(3.0) + 7.7} + \frac{1}{(1.5)(4.75)} \right] = 11\,400 \text{ A}$$

The system R could be calculated and a correction factor based on X/R determined. However, since this correction factor will be 1.0 for voltages below 6.6 kV and since the current determined is already less than the symmetrical interrupting capability, it is not necessary to make this refinement.

The symmetrical component of current at 0.5 cycle is

$$13\,900 \left[\frac{1}{1.87 + 0.10} + \frac{1}{3.45 + 1.10} + \frac{1}{(16.8)(1.2) + 7.7} + \frac{1}{4.75} \right] = 13\,500 \text{ A}$$

The symmetrical interrupting capability is adequate. Since 1.6 times the symmetrical component of the 0.5-cycle current (21 600 A) does not exceed the circuit breaker closing and latching capability (34 000 A), the breaker is satisfactory for service at Position A in Figure 16.

6.4.2 Resistance of system and typical X/R ratio

For the purpose of determining the equivalent X/R ratio, it is recommended that the manufacturer's advice be obtained concerning the resistance value to be used for important electrical devices. For machines, the required X/R ratio is a measure of the time constant of the exponential decay of the dc component of machine current for a fault at its terminals. In the absence of manufacturer's recommendations, the approximate values of resistance listed in Table 8 are suggested. In both cases, measured values on rotating machines should be converted to normal operating temperature. In setting up the R network of any system, rotating machine resistance values obtained from the manufacturer or through use of Table 8 should be adjusted by the applicable rotating machine reactance multipliers from Table 7.

Table 8—Approximate values of resistance

System components	Approximate resistance
Turbine generators and condensers	Effective resistance ^a
Salient pole generators and motors	Effective resistance ^a
Induction motors	1.2 times the dc armature resistance
Power transformers	AC load loss resistance (not including no-load losses or auxiliary losses)
Reactors	AC resistance
Lines and cables	AC resistance

$$^a\text{Effective resistance} = X_{2v} / 2\pi f T_{a3}$$

where

X_{2v} is the rated voltage negative-sequence reactance,

T_{a3} is the rated voltage generator armature time constant (s).

The effective resistance is usually about 1.2 times dc resistance.

The ranges and typical values of the X/R ratios of system components may be obtained from Table 9. An estimate of the total system equivalent X/R ratio to the point of fault may be obtained from Table 10.

Based on class of transformer, obtain the proper factor from the table below. Multiply the transformer MVA-ampere rating by this factor before using Figure 17 to obtain the typical X/R value.

Class	Rating in MVA	Factor
OA	All ratings	1.67
FA	Up to 14.9	1.33
FA	16 and up	1.25
FOA	All ratings	1.00

Table 9—Range and typical values of X/R ratios of system components at 60 Hz

System component	Range	Typical values
Large generators and hydrogen-cooled synchronous condensers	40–120	80
Power transformers	see Figure 18	—
Induction motors	see Figure 18	—
Small generators and synchronous motors	see Figure 19	—
Reactors	40–120	80
Open wire lines	2–16	5
Underground cables	1–3	2

NOTE—Actual values should be obtained, if practical.

Table 10—Equivalent system X/R ratios (at 60 Hz) at typical locations for quick approximations

Type of circuit	Range
Synchronous machines connected directly to the bus or through reactors	40–120
Synchronous machines connected through transformers rated 100 MVA and larger	40–60
Synchronous machines connected through transformers rated 25 MVA to 100 MVA for each three-phase bank	30–50
Remote synchronous machines connected through transformers rated 100 MVA or larger for each three-phase bank, where the transformers provide 90% or more of the total equivalent impedance to the fault point	30–50
Remote synchronous machines connected through transformers rated 10 MVA to 100 MVA for each three-phase bank, where the transformers provide 90% or more of the total equivalent impedance to the fault point	15–40
Remote synchronous machines connected through other types of circuits, such as: transformers rated 10 MVA or smaller for each three-phase bank, transmission lines, distribution feeders, etc.	15 or less

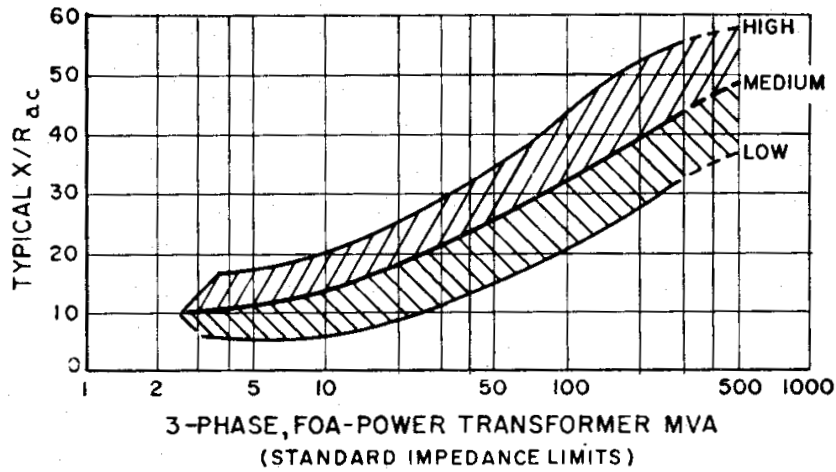

Figure 17—X/R range for power transformers at 60 Hz

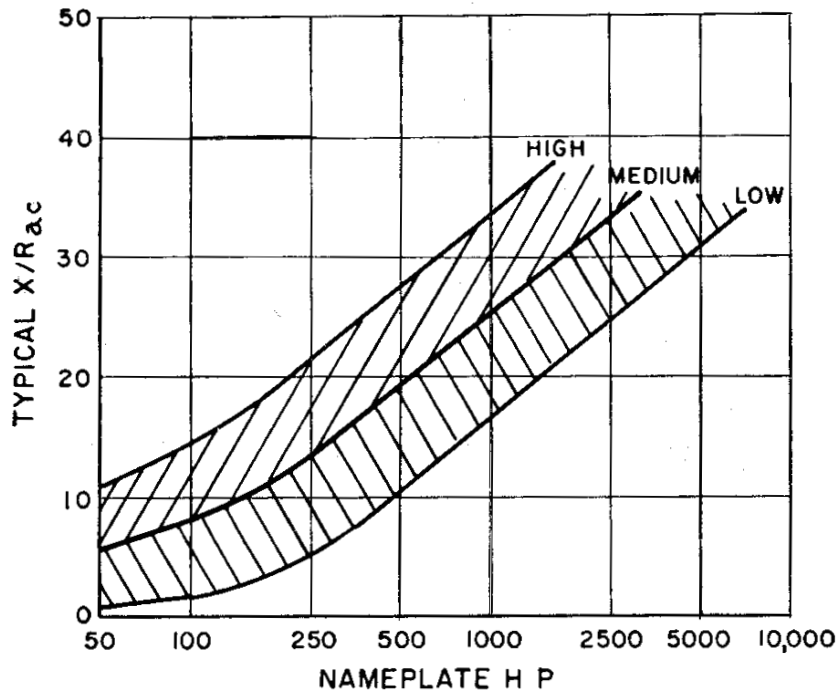

Figure 18—X/R range for three-phase induction motors at 60 Hz

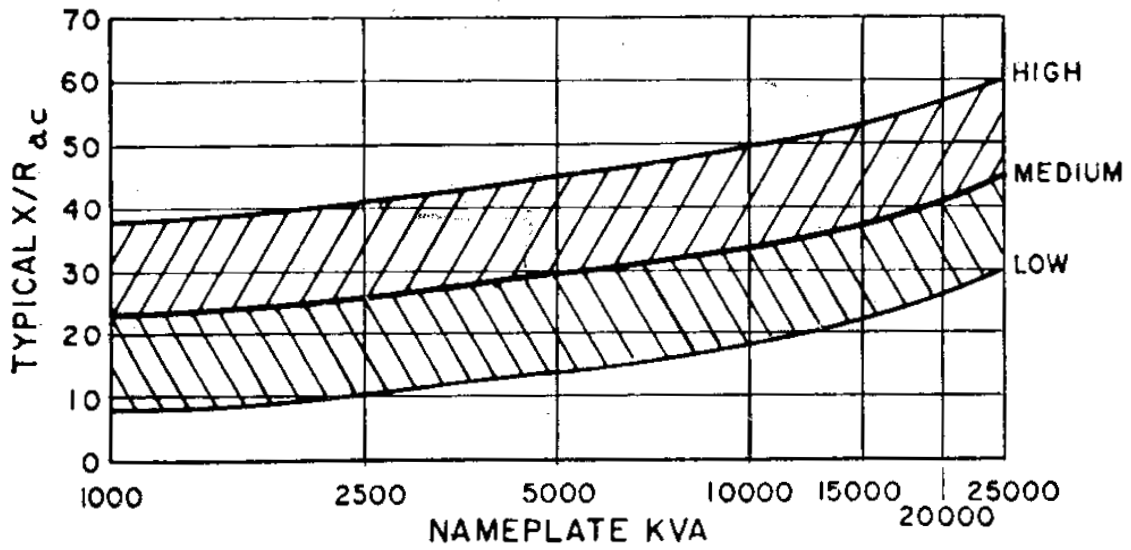

Figure 19—X/R range for small solid rotor and salient pole generators and synchronous motors at 60 Hz

Annex A

(informative)

Basis for E/X method corrected for ac and dc decrements in the calculation of short-circuit currents

A.1 Introduction

The methods used in developing the application guide for the more accurate procedure described in 6.3.2 are covered in this annex. This annex shows the derivations that permit the use of a semi-rigorous procedure for short-circuit current calculations. It avoids the intricate procedure required in the rigorous procedure while providing a degree of accuracy that is within the practical limits of short-circuit calculation considering the accuracy of constants that are usually available for such computations.

Of primary importance to any application procedure is the method for determining the value of short-circuit current that a circuit breaker must interrupt. A method of calculation (see Skuderna [B8]⁴) that employs correction factors for application to E/X short-circuit calculations has been suggested. The correction factors are based on the system X/R values at the point of fault. That method does not account for any decay in the symmetrical component of the short-circuit current. It, therefore, often gives overly conservative results, particularly for faults that are near generation. The application procedures developed in this annex employ the basic principles proposed by the earlier paper (see Skuderna [B8]) and, in addition, include the current value which is to be used in selecting a circuit breaker.

A.2 Application methods

Two methods of short-circuit calculation are described in 6.3.1 and 6.3.2 of this guide. The E/X simplified method and its limitations are described in 6.3.1. The method, as described in 6.3.2, is the more accurate method that, although semi-rigorous so far as accuracy of results are concerned, is relatively simple to use. It is recommended for accuracy that this method be used when the following conditions occur:

- a) Three-phase short circuits exceed 80% of the circuit breaker symmetrical interrupting capability.
- b) Line-to-ground short circuits exceed 70% of the circuit breaker symmetrical interrupting capability for single line-to-ground faults.

This annex gives the supporting technical data for the procedure described in 6.3.2.

A.3 Effects of ac component decrement

The need for proper recognition of the decay in the symmetrical component of short-circuit current is clearly evident from the decrement curve calculations that have been made for short-circuit applications at or near a source of generation. Evidence of this nature, including decrement effects on the total short-circuit calculated and test results, is presented in an AIEE Committee report [B2].

Further evidence is included in the sample figures in this annex. The data are based upon calculated decrement in both the ac component and in the total short-circuit current for machines of various manufacture. In

⁴The numbers in brackets correspond to those of the bibliography in Annex C.

determining short-circuit current decrements for these cases, a three-phase short-circuit was assumed. The single line-to-ground fault condition is discussed later in this annex. The calculated data obtained by a rigorous calculation procedure are shown in Table A.1.

Table A.1 — Calculated symmetrical current component

Figure	Generator ratings or range of ratings	Fault location	Symmetrical current component at 4 cycles, in % of E/X
A.1	107 MVA, 3600 r/min, conductor cooled	LV	62
A.2	107 MVA, 3600 r/min, conductor cooled	Remote	87
A.3	95–200 MVA, 3600 r/min, conventional cooled, composite characteristics	HV	78
A.4	35–65 MVA, 3600 r/min, composite characteristics	LV HV	68 77

LV = Fault on generator bus, low voltage.

Remote = See Figure A.2 for fault location.

HV = Fault on generating station transformer high-voltage bus fed directly by generators only, through power transformers.

From the cases presented in Table A.1, it is seen that the symmetrical component of short-circuit current at 4 cycles after short-circuit initiation can be as low as 62% of the E/X value. For the remote fault (see Figure A.2) or for the close to generating station short circuit, where there is substantial fault current contribution from a remote system, the ac decrement may be much less. However, the assumption that regardless of fault location there will be no ac decrement will result in overly conservative results.

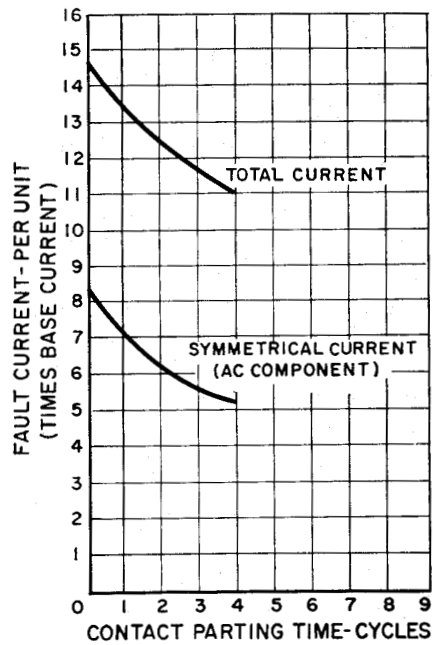

Figure A.1—Symmetrical and total current decrement three-phase short circuit 107 MVA 3600 r/min conductor-cooled turbine generator

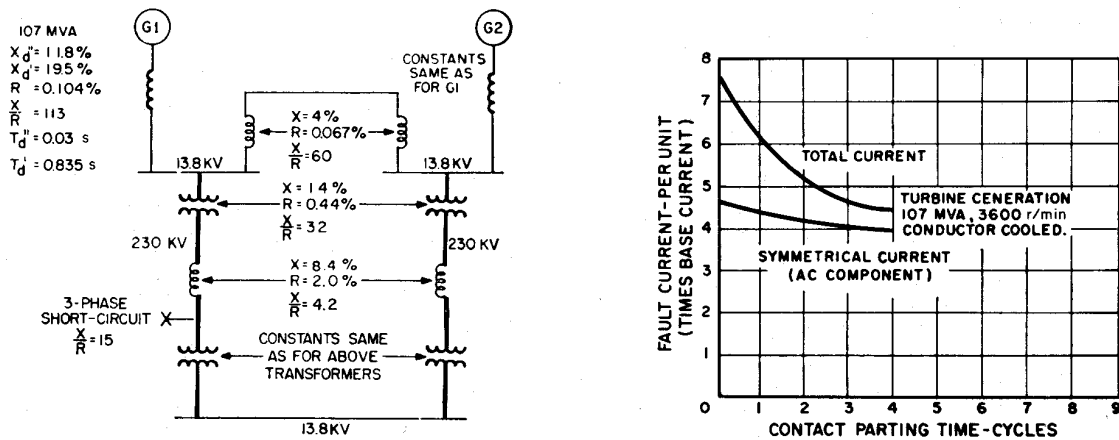
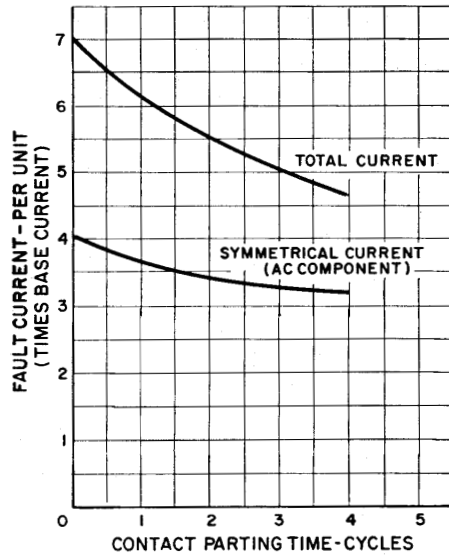

Figure A.2—Symmetrical and total current decrement three-phase short-circuit with generator and system contribution



(Faults at High Side Terminals of Generator Transformer)

Figure A.3—Symmetrical and total current decrement three-phase short-circuit representative 95–200 MVA conventional-cooled 3600 r/min turbine generators

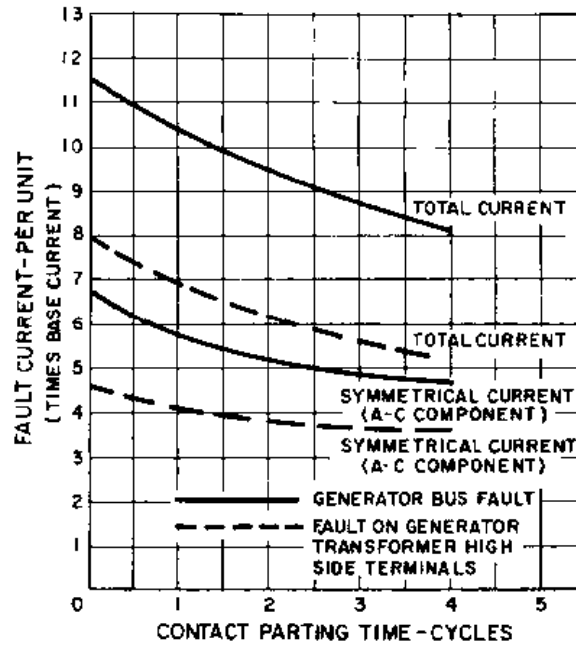

Figure A.4—Symmetrical and total current decrement three-phase short circuits representative 35–65 MVA 3600 r/min turbine generators

A.4 Derivation of E/X multipliers

Figure A.5 shows the relationship of fault current $(I_{asym}/I_{sym})_{nacd}$ (the subscript $nacd$ indicates that there is assumed to be no ac decrement) as a function of X/R for various contact parting times. This family of curves, which considers only the decay of the dc component of fault current, forms the basis of a recent application proposal (see Skuderna [B8]). The curves also form the starting point for the derivation of E/X multipliers for this proposal.

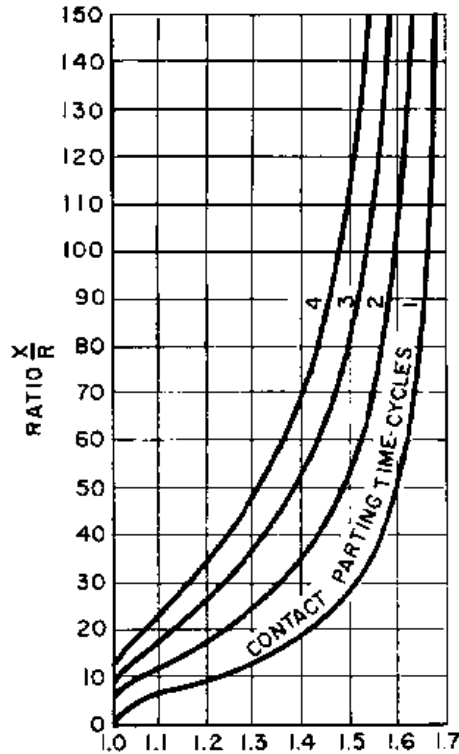

Figure A.5—Relationship of $(I_{asym}/I_{sym})_{nacd}$ to X/R at 60 Hz for several breaker contact parting times

Figure A.6 illustrates the method used to modify the curves of Figure A.5 so that the decay of the symmetrical component of fault current will be taken into account. Figure A.6 (a) indicates the general relationship of X/R to the ac decrement as the fault location moves from the generating station bus out to a remote location. This empirical relationship is shown as a band to account primarily for the variations in generator constants for 3600 r/min machines of various (from very small to very large) apparent power ratings of various manufacture. If considered alone, 1800 r/min machines would fall above this band; but when considered in combination with 3600 r/min units, they fall within the band. Even with 1800 r/min machines alone, the error in calculated current is negligible at contact parting times up to 4 cycles. As will be demonstrated later, the upper curve of this band is used to determine the E/X multipliers, since this gives the more conservative answers in terms of circuit breaker application.

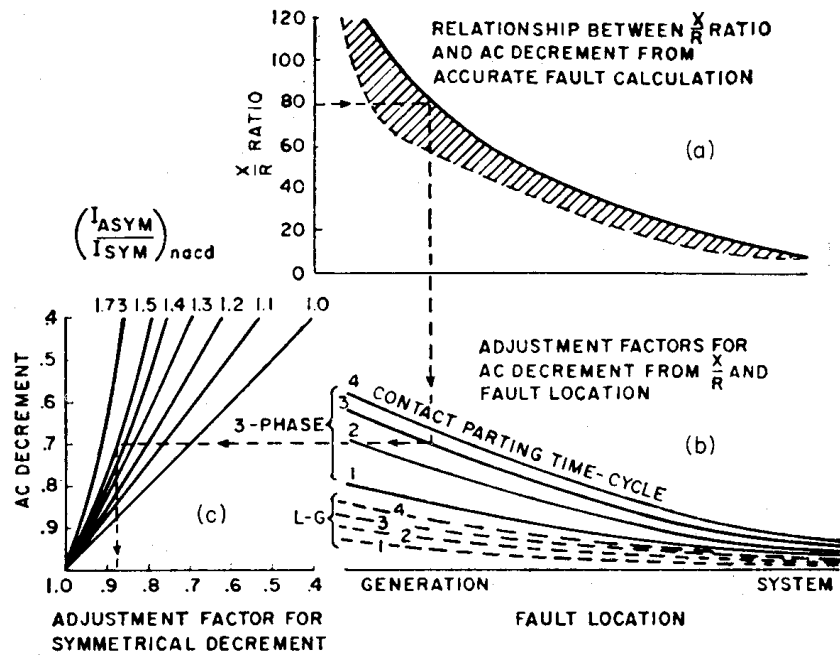

Figure A.6—Relationship between X/R ratio and ac decrement from accurate fault calculation (at 60 Hz)

Water wheel generator characteristics generally fall somewhat above the band indicated. Although separate E/X multipliers could be developed for hydro-generator circuit breaker application, the typical example shown in Figure A.7 indicates that the multipliers developed in Figure A.8 give adequately accurate results.

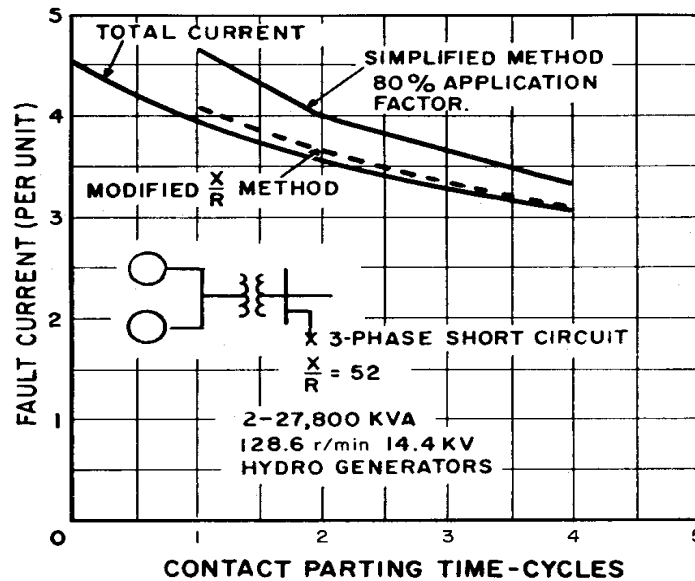

Figure A.7—Illustration of accuracy of fault determination of hydro-generation three-phase fault at high side terminals of station step-up transformers

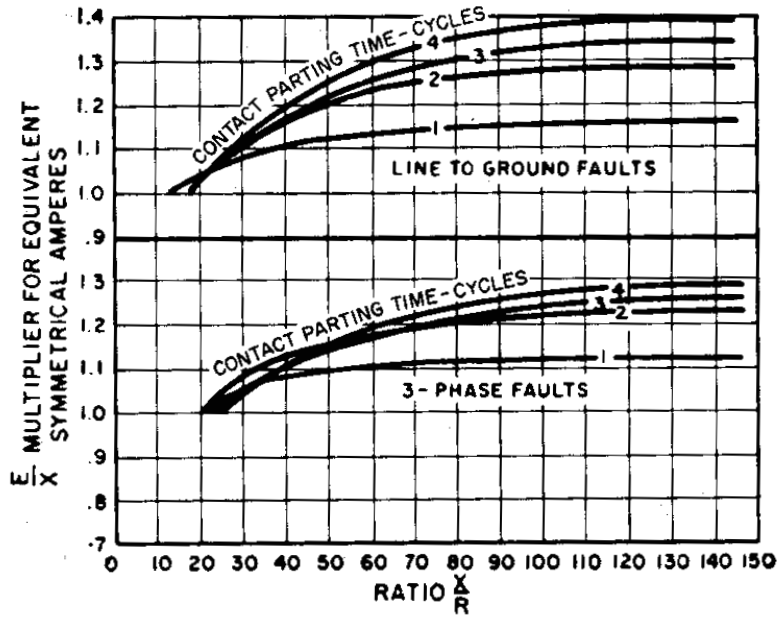

Figure A.8— E/X multiplier for equivalent symmetrical amperes for actual X/R (at 60 Hz)

Figure A.6(b) shows the decay of the symmetrical component of fault current at various time intervals after fault initiation. Again, because of variations in machine and system constants, individual points plotted on this figure result in erratic patterns.

In order to remain on the conservative side, points showing the least ac decrements were favored to establish the curves shown in Figure A.6(b) plot. As far as E/X multipliers for breaker application are concerned, a reduction from the initial symmetrical E/X current with time has the same effect as a reduction in X/R , if only dc decrement was considered. Figure A.6(c) establishes reduction factors that can be applied to $(I_{asym}/I_{sym})_{nacd}$ ratios of Figure A.5 to obtain this effect. For a given X/R ratio, the reduction factors to be applied to the $(I_{asym}/I_{sym})_{nacd}$ ratios of Figure A.5 are obtained from the following relationship:

$$\text{Reduction factors} = \frac{\sqrt{I_{ac}^2 + I_{dc}^2}}{E/X} \left(\frac{I_{asym}}{I_{sym}} \right)_{nacd}$$

A step-by-step analysis will aid in understanding the manner in which Figure A.6 was used to modify Figure A.5 to account for symmetrical current decrement.

- *Step 1:* Assume a three-phase fault, an X/R ratio of 80 at 60 Hz, and time after fault initiation of 3 cycles. From Figure A.5 calculate the ratio

$$\left(\frac{I_{asym}}{I_{sym}} \right)_{nacd} = 1.5$$

- *Step 2:* Referring to Figure A.6(a) and (b), an X/R ratio of 80 at 60 Hz is related to an ac decrement of 0.70 per unit at a time of 3 cycles after fault initiation. (For this particular system, the symmetrical component of fault current has decayed to 70% of the initial E/X value.)

- *Step 3:* Following across to Figure A.6(c) and the curve labeled 1.5 [the ratio $(I_{asym}/I_{sym})_{nacd}$ obtained from Step 1], a reduction factor of 0.885 per unit is obtained.
- *Step 4:* The modifier $(I_{asym}/E/X)$ ratio for an X/R of 80 at 60 Hz is $0.885 \times 1.5 = 1.33$. This establishes one point on the three-phase modified X/R decrement curves of Figure A.9. Following the above step-by-step procedure, the family of curves shown in Figure A.9 was determined.

The final step in this derivation was to obtain E/X multipliers for breaker application. This was accomplished through the use of the modified X/R decrement curves of Figure A.9 and the breaker capability curve that shows asymmetrical to symmetrical breaker capability ratios of 1.4, 1.2, 1.1, and 1.0 for minimum breaker contact parting times of 1 cycle, 2 cycles, 3 cycles, and 4 cycles, respectively. This knowledge, in conjunction with the system decrements of Figure A.9 form the basis for E/X multipliers of Figure A.8. For example, assume an X/R of 80 at 60 Hz as in the earlier step-by-step analysis that gave a modified system $(I_{asym}/E/X)$ ratio of 1.33 for a time corresponding to a minimum breaker contact parting time of 1 cycle to 3 cycles.

3 cycles. If the $E/X (I_{sym})$ fault current calculation is now taken as 1.0 per unit, the E/X application multiplier required to ensure sufficient breaker capability is the ratio $1.33/1.1$ or 1.21 (where 1.1 is the breaker capability factor for a three-cycle contact parting time). This establishes one point for Figure A.8 that gives E/X multipliers as a function of X/R for minimum breaker contact parting times varying from 1 cycle to 4 cycles.

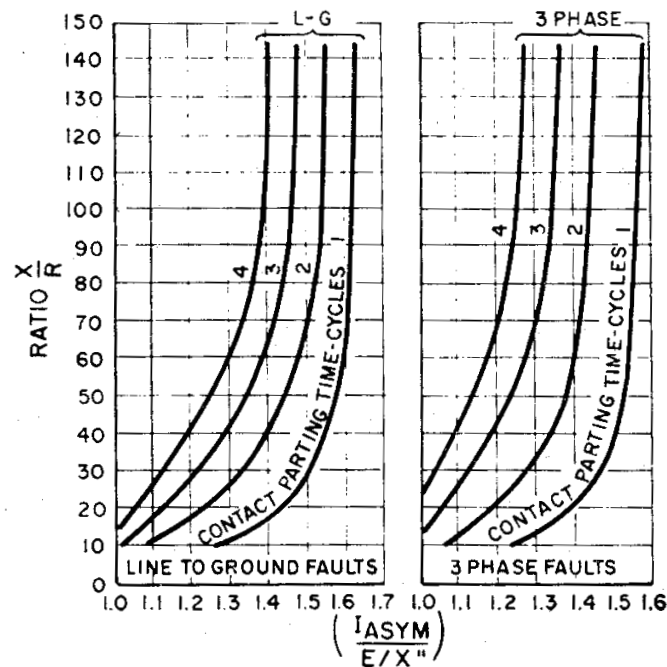

Figure A.9—Relationship of I_{asym}/I_{sym} to X/R (at 60 Hz) for several breaker contact parting times

A.5 Longer contact parting time

In certain breaker applications, breaker contact parting time in excess of the contact parting time curves of Figure A.8 can be considered. This may be true whenever relay operating time exceeds the minimum 0.5-cycle tripping delay assumed in arriving at the basic rating structure. For example, if a breaker with a minimum contact parting of 2 cycles is relayed such that it actually parts contacts 4 cycles after fault initiation, the E/X multiplier for breaker selection can be reduced to account for the fault current decay during that 2-cycle period.

Figure A.10, Figure A.11, and Figure A.12 have been so arranged as to show the multiplier to be used in the selection of breakers relayed for both minimum and longer contact parting times.

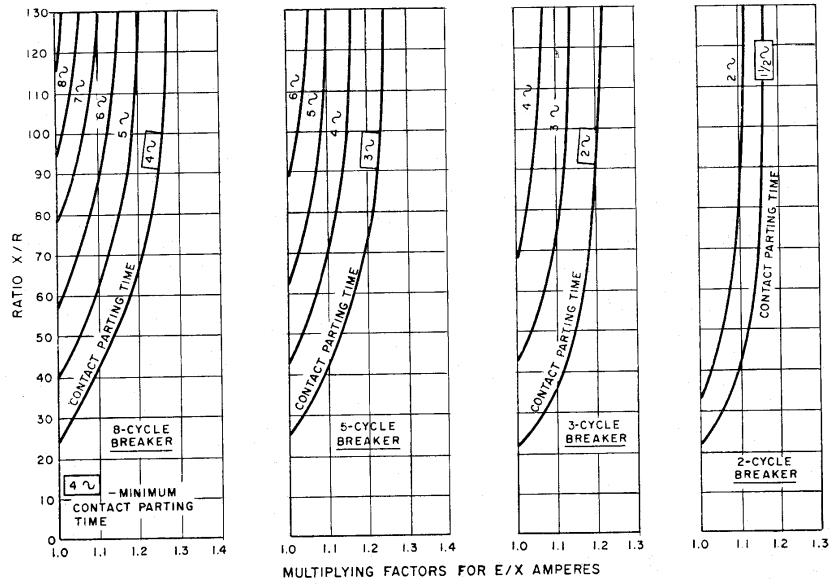

Figure A.10—Three-phase fault multiplying factors that include effects of ac and dc decrement (at 60 Hz)

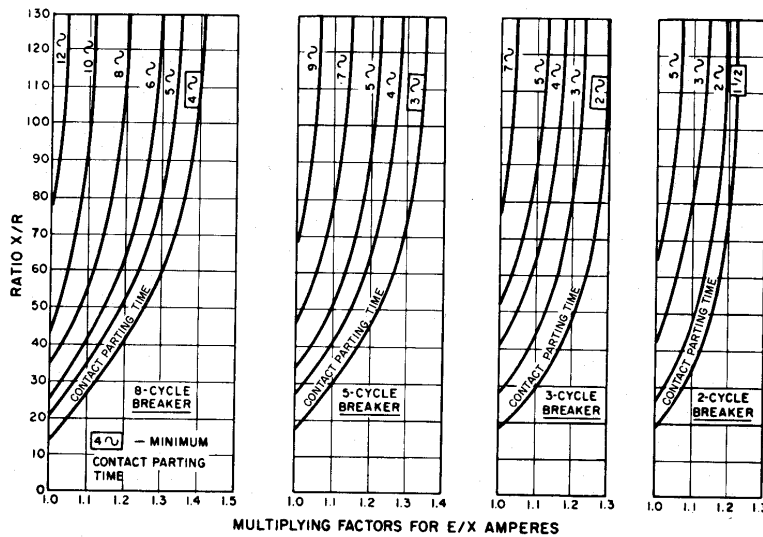

Figure A.11—Line-to-ground fault multiplying factors that include effects of ac and dc decrement

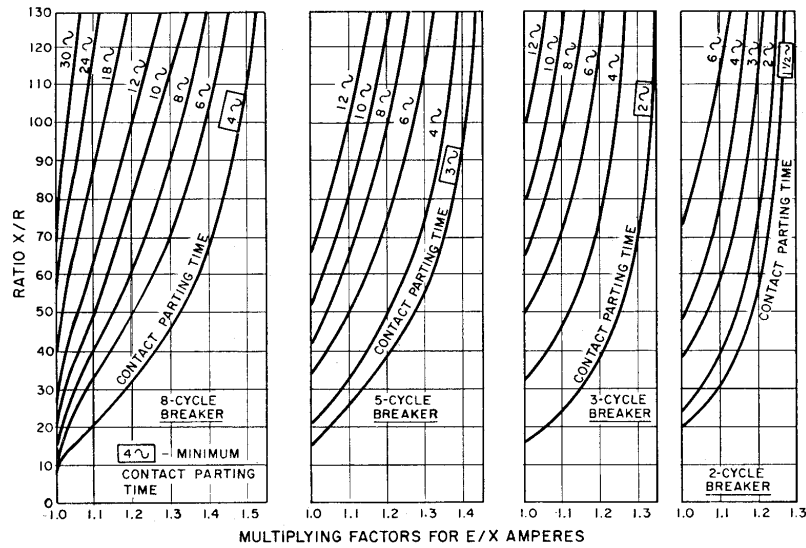

Figure A.12—Three-phase and line-to-ground fault multiplying factors that include effects of dc decrement only

A.6 Accuracy of proposed E/X multipliers

Figure A.7, Figure A.13, and Figure A.14 illustrate the accuracy of the proposed E/X multipliers for three-phase short circuits.

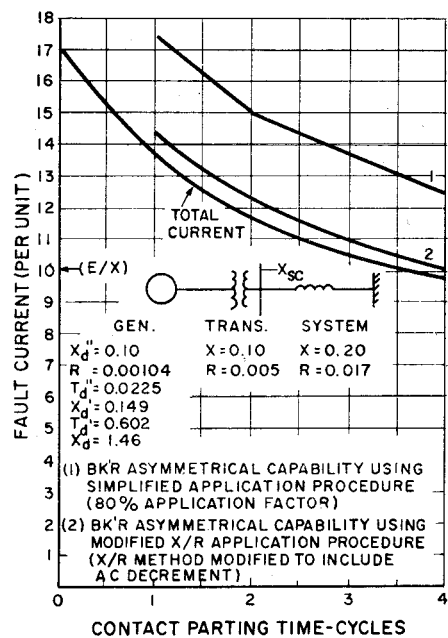

Figure A.13—Breaker asymmetrical capability

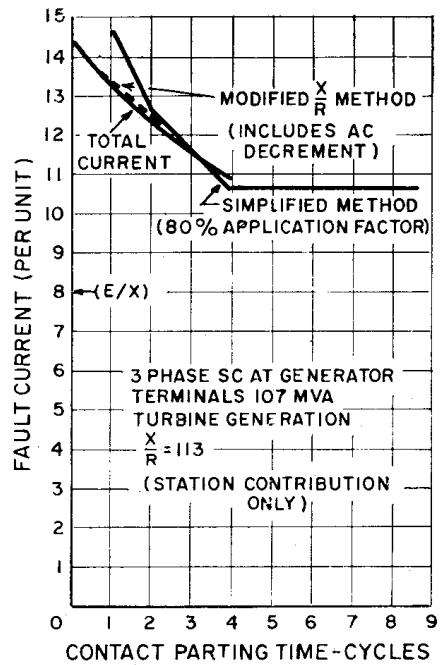

Figure A.14—Illustration of accuracy of fault determination

Curve 1 of Figure A.13 shows the necessary breaker asymmetrical capability as a function of contact parting time as calculated by the E/X simplified method (see 6.3.1). The E/X calculation of symmetrical fault current yields a value of 10 per unit (ac component). For the fault indicated, the 80% limit applies; therefore, the breaker symmetrical capability should be at least 1.25 E/X . Breaker asymmetrical capabilities indicated in curve 1 of Figure A.13 develop from the fact that the rating structure proposes percent dc components of 69%, 48%, 33%, and 23% for contact parting times of 1 cycle, 2 cycles, 3 cycles, and 4 cycles (60 Hz), respectively. These percent dc components values yield asymmetrical current ratios of 1.4, 1.21, 1.10, and 1.05 for the respective contact parting times.

Curve 2 of Figure A.13 shows the necessary breaker asymmetrical capability as a function of contact parting time as calculated by the more accurate method (see 6.3.2). In this case, it is necessary to consider both X and R networks for breaker selection. The following sample calculation will aid in the understanding of this method as used for determining the required symmetrical capability of a breaker that part contacts 2 cycles after fault initiation:

$$X \text{ to point of fault} = \frac{(0.10 + 0.10)(0.20)}{(0.10 + 0.10 + 0.20)} = 0.10$$

$$R \text{ to point of fault} = \frac{(0.00104 + 0.005)(0.017)}{(0.00104 + 0.005 + 0.017)} = 0.00447$$

Equivalent X/R to point of fault	is 22.5,
Total symmetrical fault current (E/X)	is 10 per unit,
E/X multiplier from Figure A.8	is 1.02,
Breaker required symmetrical capability (10×1.02)	is 10.2 per unit.

Since a circuit breaker with a minimum contact parting time of 2 cycles (60 Hz basis) has a percent dc component capability of 48%, it has a corresponding asymmetrical to symmetrical interrupting capability

ratio of 1.21. Thus, the required asymmetrical capability is $1.21 \times 10.2 = 12.3$ per unit. This establishes one point of curve 2 of Figure A.13. Figure A.7 and Figure A.14 are constructed similarly.

Figure A.15 and Figure A.16 illustrate the accuracy of the proposed E/X multipliers for single line-to-ground short circuits. These figures show the short-circuit current versus time characteristics for short circuits on a high-voltage bus and on a generator bus, respectively. Line-to-ground short-circuit currents have less symmetrical decrement than the three-phase short-circuit currents. The E/X simplified method should not be used for single line-to-ground faults in excess of 70% of breaker symmetrical single line-to-ground interrupting capability if supplied predominantly from generators at generator voltage (see 6.1.2). Should the calculated line-to-ground fault at these locations exceed 70% of the circuit breaker capability that the application engineer desires to use, then it becomes necessary to refer to the multipliers in Figure A.11 to check the adequacy of the breaker.

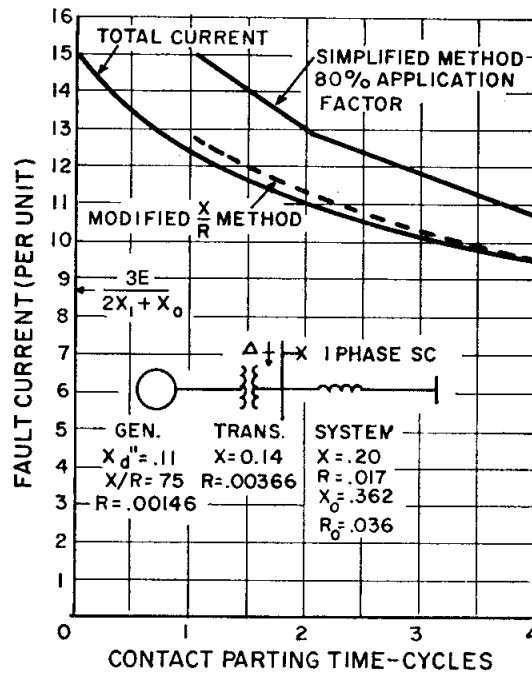

(Conventional Cooled Generator (3600 r/min)
Range 95–200 MVA)

Figure A.15—Illustration of accuracy of fault determination
single line-to-ground fault

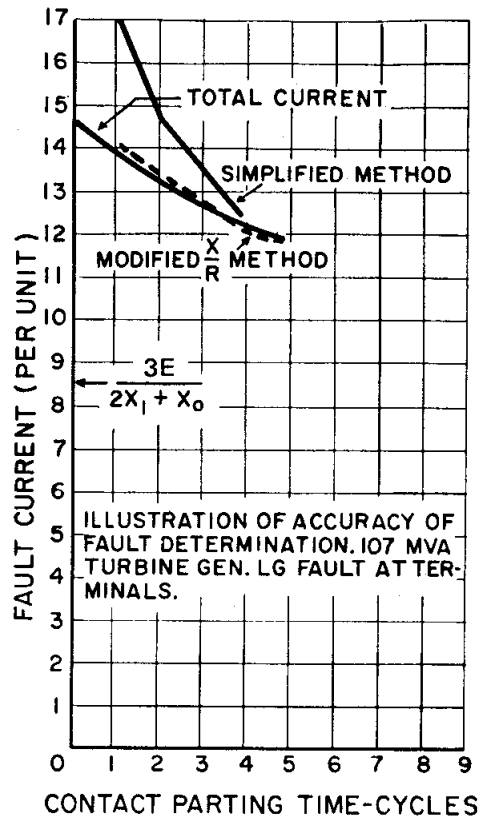

(107 MVA Turbine-Generator)

Figure A.16—Illustration of accuracy of fault determination line-to-ground fault at terminals

Annex B

(informative)

Special application circuit breakers for ac motor starting

IEEE Std C37.010-1979, approved by NEMA, and the following additions constitute Annex B of this publication.

B.1 Circuit breakers for ac motor starting

The following information is provided for the application of circuit breaker to the control of motors.

Circuit breakers for ac motor starting and running service shall be applied so that their ratings as listed in IEEE Std C37.06-1997 shall be adequate to meet the requirements as determined by location of the circuit breakers in the ac system and circuit. Figure B.1 illustrates typical methods of ac motor starting.

In addition, the following specific provisions should be considered in connection with this application of circuit breakers in order to provide satisfactory service.

B.1.1 Voltage

The voltage rating of all circuit breakers, including the circuit breakers in the reduced voltage starting and neutral circuits, as well as the line and running circuit breakers, should correspond to the voltage rating of the motor.

B.1.2 Continuous current

The continuous-current rating of each circuit breaker should not be less than the full-load current of the motor except that, in the case of part winding started motors, it should not be less than the full-load current of that winding in which the circuit breaker is located.

Circuit breakers used during the starting period only, with autotransformer or reactor starting, may have a continuous rating not less than two-thirds of the current requirement of the main circuit breaker.

If the motor has a service factor so that it can carry some percentage of the rated load current, such as 15% above normal, continuously, or has a short-time overload rating, such as 25 for 2 h, then the continuous current rating of the circuit breaker should be not less than the value determined by the service factor or by the overload rating.

B.1.3 Short-time current and short-circuit current

All circuit breakers, except neutral starting circuit breakers (designated as "N" in Figure B.1) should meet the system short-time and short-circuit current requirements.

Since they have the reactance of the motor or autotransformer windings interposed between them and the ac system, the neutral starting circuit breakers used for neutral reactor, neutral part winding, wye-delta, and

autotransformer started motors, should meet the reduced short-time and short-circuit current requirements as determined by the sum of the interposing and system reactances.

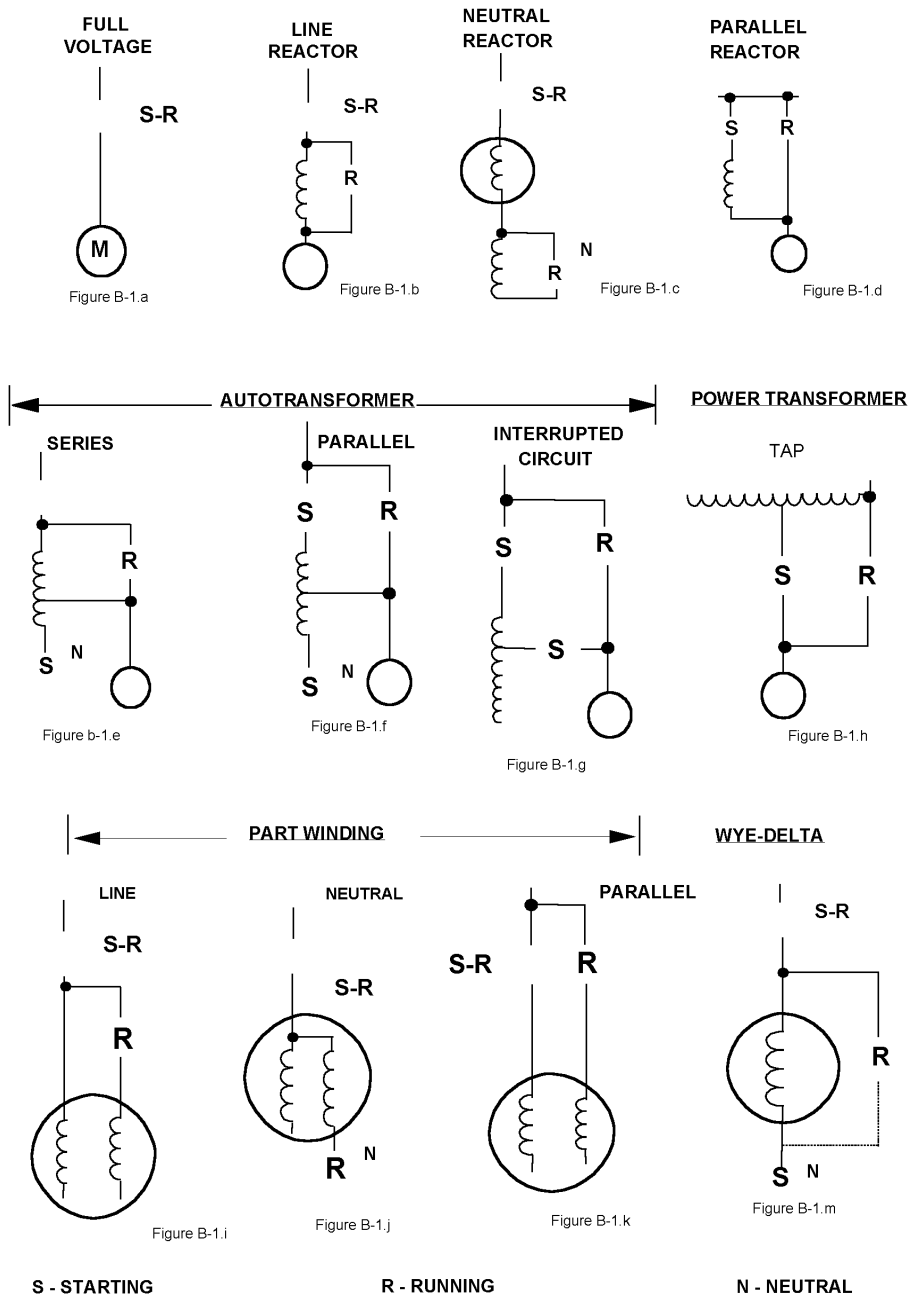

Figure B.1 – Methods of ac motor starting

B.1.4 Starting current

The maximum amount of starting currents in rms symmetrical amperes that each electrically operated circuit breaker should be required to make any time during the motor starting cycle should not exceed 30% of the short-circuit current rating of the circuit breaker at circuit voltage. The circuit breaker should not be required to carry this value of starting current for longer than 1 min.

The above percentages should apply to circuit breakers with electrical operation of “quick make and break” manual operating mechanisms; but, for circuit breakers with other types of manual operating mechanisms, the percentages should be reduced to 7.5%.

The starting current values for the various methods of motor starting as shown in Figure B.1 should be determined as follows:

- With full voltage starting (Figure B.1.a), the starting current is equal to the locked rotor current at full voltage.
- With wye-delta starting (Figure B.1.m), the starting current is equal to 0.33 of the locked rotor current on the running (delta) connection.
- With reactor starting (Figure B.1.b, Figure B.1.c, and Figure B.1.d), the starting current is determined from the sum of the reactances of the starting reactor and of the motor under locked rotor conditions.
- With part winding starting (Figure B.1.i, Figure B.1.j, and Figure B.1.k), the starting current is determined from the reactance of the motor starting winding under locked rotor conditions.
- With autotransformer reduced voltage starting (Figure B.1.e, Figure B.1.f, and Figure B.1.g) the starting current is determined where

I is locked rotor amperes at full voltage,
 P is transformer tap used (fraction of full voltage),
 I_m is rated full load current of motor,

The starting current drawing from the line is $IP^2 + 0.25I_m$, the starting current taken by the motor is IP , and the autotransformer neutral current is $IP - IP^2 + 0.25I_m$.

- With power transformer tap starting (Figure B.1.h), the starting current equals IP as covered for autotransformer reduced voltage starting.

B.2 Three-coil trip or equivalent fault protection

For overcurrent fault protection of three-phase circuits, circuit breakers shall be provided with a minimum of three overcurrent relays or trip coils, one in each phase (except that no overcurrent trip is required in a grounded phase conductor.) Where overcurrent relays operated from three current transformers are used, an overcurrent relay in the residual circuit of the current transformers shall be permitted to replace one of the phase relays.

B.3 Circuit breakers normally designed for three-phase systems when applied to single-phase systems below 100 kV having one conduct grounded

B.3.1 Voltage rating

Circuit breakers for use on single-phase systems below 100 kV having one conductor grounded shall be applied on the basis of the next higher voltage rating corresponding to 1.73 times the voltage of the circuit to ground. They shall be given the dielectric tests specified for the derived voltage rating.

Example: A circuit breaker on an 11 000 V circuit having one conductor grounded would be designed for dielectric test based on not less than 19 000 V. Consequently, a 25.8 kV circuit breaker would be required.

B.3.2 Short-circuit current rating

Where two-pole circuit breakers are applied to single-phase systems below 100 kV in each side of the circuit, they shall be rated in rms amperes corresponding to the short circuit current rating at the normal rated voltage of the circuit. In making such applications, refer to the limitations listed in IEEE Std C37.04-1999.

B.4 Neutral grounding circuit breakers

B.4.1 Rated voltage

The rated maximum voltage should at least correspond to the system nominal line-to-line voltage since the line-to-line voltage may appear across open neutral grounding circuit breakers during certain short-circuit conditions.

B.4.2 Rated current

The size of neutral grounding circuit breakers should be such that their short-time current capability will not be exceeded.

Annex C

(informative)

Bibliography

C.1 References to the text

[B1] AIEE Committee, "A New Basis for Rating Power Circuit Breakers," *AIEE Transactions (Power Apparatus and Systems)*, vol. 73, pp. 353–367, April 1954.

[B2] AIEE Committee, "Calculated Symmetrical and Asymmetrical Short-Circuit Current Decrement Rates on Typical Power Systems," *AIEE Transactions (Power Apparatus and Systems)*, vol. 75, pp. 274–285, June 1956.

[B3] AIEE Committee, "Calculation of Electric Power System Short Circuits During the First Few Cycles," *AIEE Transactions (Power Apparatus and Systems)*, vol. 75, pp. 120–127, April 1956.

[B4] *Electrical Transmission and Distribution Reference Book*, East Pittsburgh: Central Station Engineers of Westinghouse Electric Corporation, 1950.

[B5] Hahn, W. M., and Wagner, C. F., "Standard Decrement Curves," *AIEE Transactions*, vol. 51, pp. 352–361, 1932.

[B6] Kimbark, E. W., *Power System Stability*. New York: Wiley, vol. I, 1948; vol. II, 1950; vol. III, 1956.

[B7] Owen, R. E., and Lewis, W. A., "Asymmetry Characteristics of Progressive Short Circuits on Large Synchronous Generators," *IEEE Transactions on Power Apparatus and Systems*, vol. PAS-90, pp. 587–596, March/April 1971.

[B8] Skuderna, J. E., "The X/R Method of Applying Power Circuit Breakers," *AIEE Transactions (Power Apparatus and Systems)*, vol. 80, pp. 328–338, June 1959.

[B9] Wagner, C. F., "Decrement of Short Circuit Currents," *Electrical Journal*, March, April, May, 1953.

[B10] Wagner, C. F., and Evans, R. D., *Symmetrical Components*, New York: McGraw-Hill Book Company, 1933.

C.2 General references concerning short-circuit current interruption

[B11] AIEE Committee, "A New Basis for Rating Power Circuit Breakers," *AIEE Transactions (Power Apparatus and Systems)*, vol. 73, pp. 353–367, April 1954.

[B12] AIEE Committee, "Proposed Revision of American Standard Alternating-Current Power Circuit Breakers, C37.4-1953," AIEE Conference Paper No. CP-59-186, 1959.

[B13] AIEE Committee, "Simplified Calculation of Fault Currents," *Electrical Engineering*, vol. 67, pp. 1433–1435, 1948.

[B14] *Circuit Interruption: Theory and Techniques*, New York: Marcel Dekker, Inc., 1984.

- [B15] Colclaser, R. G., Wagne, C. L., and Donahue, E. P., "Multi-Step Resistor Control of Switching Surges," *IEEE Transactions Power Apparatus and Systems*, vol. PAS-88, no. 7, pp. 1022–28, July 1969.
- [B16] Dandeno, P. L., Watson, W., and Dillard, J. K., "Transient Recovery Voltage on Power Systems," *AIEE Transactions (Power Apparatus and Systems)*, vol. 77, pp. 581–592, August 1958.
- [B17] Griscom, S. B., Sauter, D. M., and Ellis, H. M., "Practical Method of Determining the Transient Recovery Voltages on Power Systems," *AIEE Transactions (Power Apparatus and Systems)*, vol. 77, pp. 592–604, August 1958.
- [B18] Hanna, W. M., Travers, H. A., Wagner, C. F., Woodrow, C. A., and Skeats, W. F., "System Short Circuit Currents," *AIEE Transactions*, vol. 60, pp. 877–881, 1941.
- [B19] Hedman, D. E., Johnson, I. B., Titus, C. H., and Wilson, D. D., "Switching of Extra-High Voltage Circuits, II—Surge Reduction with Circuit Breaker Resistors," *IEEE Transactions Power Apparatus and Systems*, vol. PAS-83, pp. 1196–1205, December 1964.
- [B20] Hileman, A. R., Wagner, C. L., and Kisner, R. B., "Open Breaker Protection of EHV Systems," *IEEE Transactions Power Apparatus and Systems*, vol. PAS-88, no. 7, pp. 1005–14, July 1969.
- [B21] Huening, W. C., Jr., "Time Variation of Industrial System Short-Circuit Currents and Induction Motor Contributions," *AIEE Transactions (Industry and General Applications)*, vol. 74, pp. 90–101, May 1955.
- [B22] Knable, A. H., "Proposed New Breaker Ratings and Their Effect on Application for Industrial Systems," *AIEE Transactions (Power Apparatus and Systems)*, vol. 80, pp. 957–963, February 1962.
- [B23] Naef, O., Zimmerman, C. P., and Beehler, J. E., "Proposed Transient Recovery Voltage Ratings for Power Circuit Breakers," *IEEE Transactions Power Apparatus and Systems*, vol. PAS-84, pp. 580–608, July 1965.
- [B24] Skeats, W. F., Titus, C. H., and Wilson, W. R., "Severe Rates of Rise of Recovery Voltage Associated with Transmission Line Short Circuits," *AIEE Transactions (Power Apparatus and Systems)*, vol. 76, pp. 1256–1266, February 1958.
- [B25] Smith, F. W., "Control Voltages for Power Switchgear," *IEEE Transactions Power Apparatus and Systems*, vol. PAS-96, no. 3, pp. 969–977, May/June 1977.
- [B26] Special Publication 75 CH 0975-3-PWR, IEEE Tutorial on Power Circuit Breakers, 1975 Winter and Summer Power Meetings.
- [B27] Special Publication 87 TH0176-8-PWR, IEEE Tutorial Power System Transient Recovery Voltages, 1987 Winter and Summer Power Meetings.
- [B28] Special Publication 93 EHO 388-9-PWR, IEEE Tutorial on Application of Power Circuit Breakers, 1994 Winter and Summer Power Meetings.
- [B29] *Transient Recovery Voltages on Power Systems (As Related to Circuit Breaker Performance)*, New York: Association of Edison Electric Illuminating Companies, 1963.
- [B30] Wagner, C. L., and Smith, H. M., "Analysis of Transient Recovery Voltage (TRV) Rating Concepts," *IEEE Transactions Power Apparatus and Systems*, vol. PAS-103, no. 11, pp. 3354–63, November 1984.

C.3 References concerning line-closing switching surge voltage control

[B31] Arismunandar, A., Price, W. S., and Miserly, A. J., "A Digital Computer Iterative Method For Simulating Switching Surge Responses of Power Transmission Networks," *IEEE Transactions*, paper no. 63-1031.

[B32] Calabro, S. R., *Reliability Principles and Practices*, New York: McGraw-Hill, 1962.

[B33] Johnson, B., Silvar, F., and Wilson, D. D., "Switching Surges Due to Energization or Reclosing," *Proceedings American Power Conference*, vol. XXIII, pp. 729-736, 1961.

[B34] Lauber, T. S., "Resistive energization of transmission lines: Part I—Single-Phase Lines and Part II—Three-Phase Lines," *IEEE Papers*, no. 31CP65-171 and no. 31CP65-174.

[B35] MIL-Std-105D, Sampling Procedures and Tables for Inspection by Attributes.

[B36] Sonnenberg, C. F., "Methods of switching surge testing based on statistical sampling theory," *IEEE Papers*, no. 31C43-C.

[B37] Truax, C. J., Brown, J. D., and Neugebauer, W., "TNA Study of Reclosing Transients on a 765 kV Shunt Compensated Transmission Line," *IEEE Transactions on Power Apparatus and Systems*, vol. 97, pp. 1447-1457, July/August 1978.

[B38] Wagner, C. L. and Bankoske, J. W., "Evaluation of Surge Suppression Resistors in High Voltage Circuit Breakers," *IEEE Papers*, no. 31CP66-112.

[B39] Wald, A., *Sequential Analysis*, New York: John Wiley & Sons, 1947.