

IEEE IEEE C62.92.4-1991(R2002)

# IEEE Guide for the Application of Neutral Grounding in Electrical Utility Systems, Part IV—Distribution

Sponsor  
**Surge-Protective Devices Committee  
of the  
IEEE Power Engineering Society**

Reaffirmed March 20, 2002  
Approved December 5, 1992

**IEEE Standards Board**

Reaffirmed August 28, 2002  
Approved July 13, 1992

**American National Standards Institute**

**Abstract:** The neutral grounding of single- and three-phase ac electric utility primary distribution systems with nominal voltages in the range of 2.4–34.5 kV is addressed. Classes of distribution systems grounding are defined. Basic considerations in distribution system grounding—concerning economics, control of temporary overvoltages, control of ground-fault currents, and ground relaying—are addressed. Also considered are use of grounding transformers, grounding of high-voltage neutral of wye-delta distribution transformers, and interconnection of primary and secondary neutrals of distribution transformers.

**Keywords:** distribution system grounding, distribution systems, electric utilities, grounding, neutral grounding, primary distribution systems

---

The Institute of Electrical and Electronics Engineers, Inc.  
345 East 47th Street, New York, NY 10017-2394, USA

Copyright © 1992 by the

Institute of Electrical and Electronics Engineers, Inc.

All rights reserved. Published 1992

Printed in the United States of America

ISBN 1-55937-20243

*No part of this publication may be reproduced in any form, in an electronic retrieval system or otherwise, without the prior written permission of the publisher.*

**IEEE Standards** documents are developed within the Technical Committees of the IEEE Societies and the Standards Coordinating Committees of the IEEE Standards Board. Members of the committees serve voluntarily and without compensation. They are not necessarily members of the Institute. The standards developed within IEEE represent a consensus of the broad expertise on the subject within the Institute as well as those activities outside of IEEE which have expressed an interest in participating in the development of the standard.

Use of an IEEE Standard is wholly voluntary. The existence of an IEEE Standard does not imply that there are no other ways to produce, test, measure, purchase, market, or provide other goods and services related to the scope of the IEEE Standard. Furthermore, the viewpoint expressed at the time a standard is approved and issued is subject to change brought about through developments in the state of the art and comments received from users of the standard. Every IEEE Standard is subjected to review at least once every five years for revision or reaffirmation. When a document is more than five years old, and has not been reaffirmed, it is reasonable to conclude that its contents, although still of some value, do not wholly reflect the present state of the art. Users are cautioned to check to determine that they have the latest edition of any IEEE Standard.

Comments for revision of IEEE Standards are welcome from any interested party, regardless of membership affiliation with IEEE. Suggestions for changes in documents should be in the form of a proposed change of text, together with appropriate supporting comments.

Interpretations: Occasionally questions may arise regarding the meaning of portions of standards as they relate to specific applications. When the need for interpretations is brought to the attention of IEEE, the Institute will initiate action to prepare appropriate responses. Since IEEE Standards represent a consensus of all concerned interests, it is important to ensure that any interpretation has also received the concurrence of a balance of interests. For this reason IEEE and the members of its technical committees are not able to provide an instant response to interpretation requests except in those cases where the matter has previously received formal consideration.

Comments on standards and requests for interpretations should be addressed to:

Secretary, IEEE Standards Board  
445 Hoes Lane  
P.O. Box 1331  
Piscataway, NJ 08855-1331  
USA

IEEE Standards documents are adopted by the Institute of Electrical and Electronics Engineers without regard to whether their adoption may involve patents on articles, materials, or processes. Such adoption does not assume any liability to any patent owner, nor does it assume any obligation whatever to parties adopting the standards documents.

## Introduction

(This introduction is not a part of IEEE C62.92.4-1991, IEEE Guide for the Application of Neutral Grounding in Electrical Utility Systems, Part IV—Distribution.)

This guide was prepared by the Working Group on the Neutral Grounding of Distribution Systems of the IEEE Surge-Protective Devices Committee. The guide deals with the neutral grounding of single- and three-phase ac utility primary distribution systems with nominal voltages of 2.4 kV through 34.5 kV. Not included are grounding of low-voltage secondary systems or consumer-owned facilities that are covered by other standards. At the time this guide was approved, the working group membership was as follows:

### **J. J. Burke**, *Chair*

S. H. Cheng  
J. L. Koepfinger  
R. Richeda

D. C. Dawson  
S. Mazumdar  
D. R. Smith

G. S. Haralampu  
M. Parente  
E. R. Taylor

The following persons were on the balloting committee that approved this document for submission to the IEEE Standards Board:

R. D. Ball  
C. L. Ballentine  
G. D. Breuer  
J. J. Burke  
S. Cheng  
M. G. Comber  
J. G. Dalton  
D. C. Dawson  
C. C. Erven  
R. W. Flugum  
H. E. Foelker  
G. L. Gaibrois  
E. A. Goodman  
P. A. Goodwin  
C. D. Hansell  
G. S. Haralampu  
D. E. Hedman

J. A. Hetrick  
A. R. Hileman  
W. W. Hines  
D. W. Jackson  
R. A. Jones  
S. S. Kershaw  
J. L. Koepfinger  
G. E. Lee  
F. Lembo, Jr.  
D. W. Lenk  
W. A. Maguire  
J. A. Mambuca  
E. H. Marrow, Jr.  
F. D. Martzloff  
D. J. Melvold  
J. J. Napiorkowski  
O. Nigol

R. Odenberg  
J. C. Osterhout  
M. Parente  
J. B. Posey  
S. A. Potocny  
P. Richman  
K. B. Stump  
L. D. Sweeney  
A. Sweetana  
D. P. Symanski  
E. R. Taylor, Jr.  
R. Thallam  
A. C. Westrom  
S. G. Whisenant  
E. J. Yasuda

At the time this standard was published, it was under consideration for approval as an American National Standard. The Accredited Standards Committee on Surge Arresters, C62, had the following members at the time this document was sent to letter ballot:

Joseph L. Koepfinger, *Chair*  
 John A. Gauthier, *Secretary*

<i>Organization Represented</i> .....	<i>Name of Representative</i>
Association of American Railroads .....	Wayne Etter
Bonneville Power Administration .....	G.E. Lee
Exchange Carriers Standards Association .....	Michael Parente
Electric Light and Power .....	R. A. Jones H. E. Foelker W. A. Maguire Dale Peters J. W. Wilson M.C. Mingoia( <i>Alt.</i> )
Institute of Electrical and Electronic Engineers .....	J. L. Koepfinger G. L. Gaibrois C. Nansell ( <i>Alt.</i> ) Dale Hedman W. H. Kapp S. S. Kershaw, Jr. Edgar Taylor ( <i>Alt.</i> )
National Electrical Manufacturers Association .....	Scott Law Basil Dillon-Malone Dennis W. Lenk Bernhard Wolff D. Worden David Bell ( <i>Alt.</i> ) Larry Bock ( <i>Alt.</i> )
Rural Electrification Administration .....	George J. Bagnall
Underwriters Laboratories .....	P. Notarian Larry Williams( <i>Alt.</i> )
Canadian Standards Association .....	D. M. Smith
Members-at-Large .....	Peter Goodwin F. D. Martzloff J. Osterhout B. Panesar

When the IEEE Standards Board approved this standard on December 5, 1991, it has the following membership:

**Marco W. Migliaro**, *Chair*  
**Donald C. Loughry**, *Vice Chair*  
**Andrew G. Salem**, *Secretary*

Dennis Bodson  
Paul L. Borrill  
Clyde Camp  
James M. Daly  
Donald C. Fleckenstein  
Jay Forster\*  
David F. Franklin  
Ingrid Fromm  
Thomas L. Hannan

Donald N. Heirman  
Kenneth D. Hendrix  
John W. Horch  
Ben C. Johnson  
Ivor N. Knight  
Joseph Koepfinger\*  
Irving Kolodny  
Michael A. Lawler  
John E. May, Jr.

Lawrence V. McCall  
T. Don Michael\*  
Lloyd A. "Pete" Morley  
Stig L. Nilsson  
John L. Rankine  
Ronald H. Reimer  
Gary S. Robinson  
Terrance R. Whittemore

\*Member Emeritus

Also included are the following nonvoting IEEE Standards Board liaisons:

Fernando Aldana  
Satish K. Aggarwal

James Beall  
Richard B. Engelman

Stanley Warshaw

Mary Lynne Nielsen  
*IEEE Standards Project Editor*

CLAUSE	PAGE
1. Scope .....	1
2. Classes of Distribution Systems Grounding .....	1
2.1 Ungrounded Systems .....	1
2.2 Grounded Systems .....	1
2.3 Four-Wire Unigrounded Systems .....	2
2.4 Three-Wire Unigrounded Systems .....	2
2.5 Use of Grounding Transformers .....	2
3. Basic Considerations in Distribution System Grounding .....	2
3.1 Economics .....	3
3.2 Control of Temporary Overvoltages .....	3
3.3 Control of Ground Fault Currents .....	6
3.4 Ground Relaying .....	9
4. Special Considerations in Distribution System Grounding .....	10
4.1 Coordination With Communication Facilities .....	10
4.2 Use of Grounding Transformers .....	12
4.3 Grounding of High-Voltage Neutral of Wye-Delta Distribution Transformers .....	12
4.4 Interconnection of Primary and Secondary Neutrals of Distribution Transformers .....	13
5. Bibliography .....	13
Annex A (Informative) Specifying a Zig-Zag Grounding Transformer .....	16
Annex B (Informative) Techniques for Interconnecting Primary and Secondary Neutrals .....	20

# IEEE Guide for the Application of Neutral Grounding in Electrical Utility Systems, Part IV – Distribution

## 1. Scope

This section of the guide is concerned with the neutral grounding of single- and three-phase alternating current (ac) electric utility primary distribution systems with nominal voltages in the range of 2.4 kV to 34.5 kV. For the purpose of this guide, the term “distribution” includes the substation providing power to distribution feeders, the distribution feeders, and the distribution transformers providing service at utilization voltages. The scope of this guide does not include the grounding of the low-voltage secondary systems supplied by distribution transformers, or consumer-owned facilities that are covered by other standards such as the National Electrical Code (NEC) [B6].

## 2. Classes of Distribution Systems Grounding

Distribution systems are classified as being either grounded or ungrounded.

### 2.1 Ungrounded Systems

Ungrounded systems have the secondary windings of the distribution substation transformer connected either in ungrounded delta or ungrounded wye, with the former connection being more common. The distribution feeders are three-wire three-phase and two-wire single-phase circuits. Surge arresters are connected from phase conductor directly to earth, or to the grounded equipment tank or frame, either directly or through a spark gap.

### 2.2 Grounded Systems

Grounded systems usually are derived from a distribution substation transformer with wye-connected secondary windings and with the neutral point of the windings solidly grounded or connected to ground through a noninterrupting, current-limiting device such as a reactor, etc. A grounding transformer may also be used to establish a grounded system. The circuits associated with grounded distribution systems generally have a neutral conductor connected to the supply grounding point. The neutral conductor of the distribution circuits may be connected to earth at frequent intervals (multigrounded), or it may be fully insulated and have no other earth connection except at the

source (ungrounded). In three-wire ungrounded systems, a neutral conductor is not run with each circuit, but the system is grounded through the connections of the substation transformer or grounding transformer. The neutral conductor associated with the primary feeders of multigrounded neutral distribution systems is connected to earth at intervals specified by national or local codes. It is also common practice to bond this neutral conductor to surge-arrester ground leads and to all noncurrent-carrying parts, such as equipment tanks and guy wires, and to interconnect it with the secondary neutral conductor or grounded conductor. In some situations, the same neutral conductor is used for both the primary and secondary systems. There is some variation in this practice, however, and some utilities do not interconnect the primary and secondary neutral conductors nor bond the neutral to the guy wire. If no direct interconnection is made, the secondary neutral conductor may be connected to the primary neutral conductor through a spark gap or arrester.

Surge arresters on multigrounded neutral systems are connected directly to earth, and their grounding conductor may be interconnected directly to the primary neutral conductor and equipment tanks. They may also be interconnected with the secondary neutral at transformer installations.

### **2.3 Four-Wire Ungrounded Systems**

Four-wire ungrounded systems are systems where the primary neutral conductor is insulated at all points except at the source. The neutral conductor in these systems is connected to the neutral point of the source transformer windings and to ground. Distribution transformers usually are connected between phase and neutral conductors, with the surge arrester connected between phase and ground. Some four-wire ungrounded systems use an arrester between the neutral conductor and ground. A spark gap may also be used at the distribution transformer between its secondary neutral and arrester ground to provide better surge protection to the transformer windings. The principal advantage of four-wire ungrounded systems is the greater ground relaying sensitivity that can be obtained in comparison to multigrounded systems (see 3.4).

### **2.4 Three-Wire Ungrounded Systems**

On three-phase three-wire primary distribution circuits, single-phase distribution transformers are connected phase-to-phase. The connection three single-phase distribution transformers or of three-phase distribution transformers is usually delta-grounded wye or delta-delta. The floating wye-delta or T-T connections also can be used. The grounded wye-delta connection is generally not used because it acts as a grounding transformer. Surge arresters are generally connected phase-to-ground. However, the surge arrester rating is higher than those used on multigrounded neutral systems since the temporary 60 Hz overvoltages expected under fault conditions are also higher.

### **2.5 Use of Grounding Transformers**

The feeders from an ungrounded systems may be grounded by the use of a grounding transformer, which may be connected in zig-zag or in grounded-wye delta. The grounding transformer provides a source for zero sequence current and will permit the addition of a neutral conductor to an existing ungrounded circuit.

## **3. Basic Considerations in Distribution System Grounding**

The basic considerations in distribution system grounding are economics, control of overvoltages, control of fault current magnitude and return path, and ground fault protection.



### 3.1 Economics

Ungrounded and three-wire ungrounded systems generally result in the least investment when the load is mostly three-phase. On the other hand, costs favor multigrounded neutral systems when the loads are mostly single phase. Several factors must be given consideration to determine if the system should be grounded or ungrounded.

One factor to consider is the geographical area and the isokeraunic level in which the system will be operating. This will have considerable effect on the type of surge arresters required and the degree of direct-stroke protection that is considered necessary. In an area having a high isokeraunic level, it may be advantageous to use a static wire or an overhead shield wire for direct stroke lightning protection. The primary neutral conductor can very easily be used for the shield wire and may also function as a common neutral conductor with the secondary system. However, with the use of aerial cable for secondary circuits, there will be some duplication of neutral conductors that may not be objectionable compared with the reduced outages and reduction of trips for fuse replacement and repair of lightning-damaged equipment. Also, the number of ground connections on the neutral conductor per mile of line must be considered.

Generally, a minimum of four ground connections per mile is considered adequate for a four-wire multigrounded neutral system, but, with the use of a static or overhead shield wire, it may be necessary to install grounds on every pole.

Another method of providing lightning protection that is affected by the type of grounding is the use of surge arresters installed on each conductor at intervals of approximately every 394 m (1200 ft). The voltage rating of the arrester is directly related to the effectiveness of grounding employed on a particular system. For example, the arresters on a three-wire three-phase ungrounded system would need a voltage rating suitable for the phase-to-phase voltage. On the other hand, on an effectively grounded four-wire three-phase circuit, the arresters may have a voltage rating of only 75% of the phase-to-phase voltage. This may also allow the use of equipment having a lower Basic Insulation Level (BIL).

The use of multigrounded neutral distribution systems that satisfy the requirements of effectively grounded systems provides several areas in which reduced costs can be realized.

- 1) The National Electrical Safety Code (NESC) [B2] permits neutral conductors that are multigrounded on systems of 50 kV and below to be attached directly to the structure surface. The same neutral conductor may be used for both the primary and secondary systems.
- 2) Lower surge-arrester voltage ratings can be used.
- 3) Lower surge-arrester voltage ratings may permit lower equipment BIL, especially at the higher distribution voltages.
- 4) Equipment costs are reduced since it is necessary to use only one fuse cutout, arrester, and primary bushing on a single-phase distribution transformer.
- 5) The earth acts as a conductor in parallel with the neutral, sometimes allowing reduced conductor size and a decrease in losses. A reduced neutral conductor size will increase ground current and may produce or increase neutral-to-earth voltage.
- 6) Single-phase distribution transformers with one high-voltage bushing may have a primary winding with reduced insulation at the neutral end. Three-phase distribution transformers with the primary windings connected in grounded wye may also have reduced insulation at the neutral end.

### 3.2 Control of Temporary Overvoltages

#### 3.2.1 Faults to Ground

Faults to ground on power systems may cause fundamental frequency overvoltages on the unfaulted phases, which last for the duration of the fault. The grounding of the system determines the magnitude of these overvoltages, which in turn establishes the minimum voltage rating of surge arresters used on the system.

Based upon an evaluation of circuit parameters, operating voltage limits, type of construction, and distribution transformer magnetizing characteristics, a proposal for the selection of voltage ratings of silicon-carbide distribution-class surge arresters has been made by a working group of the IEEE Surge-Protective Devices Committee<sup>1</sup>. The group proposed that the duty cycle voltage rating of surge arresters selected for open-wire multigrounded neutral systems be equal to or greater than the nominal line-to-neutral voltage multiplied by the product of the Range A factor 1.05 (from ANSI C82.1-1985 [B3]), and 1.2, which is the maximum voltage rise on the unfaulted phases of a loaded circuit. This is equivalent to 1.25 times nominal line-to-neutral system voltage.

Similarly, for spacer-cable systems, a factor not exceeding 1.58 appears reasonable as the maximum value of overvoltage on the unfaulted phases of a three-phase circuit during single phase-to-ground faults. Taking into account connected distribution transformers, the factor reduces to 1.46. Thus, for spacer-cable systems, the duty cycle voltage rating of arresters should be based on the nominal line-to-neutral voltage multiplied by the product of the Range A factor 1.05 and 1.46. This is equivalent to 1.5 times nominal line-to-neutral system voltage.

The highest voltage an arrester will normally experience has traditionally been computed by considering a single line-to-ground fault as shown in Fig 1 .

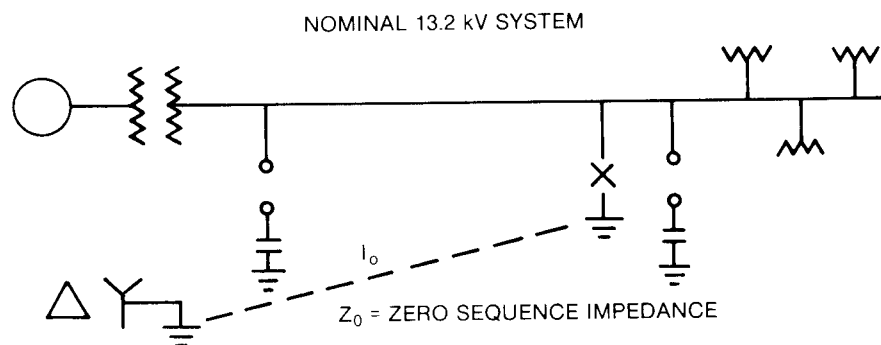

**Figure 1—Single Line-to-Ground Fault**

The voltage to ground on the unfaulted phases will increase by an amount that is a function of system impedances as illustrated in Fig 2 .

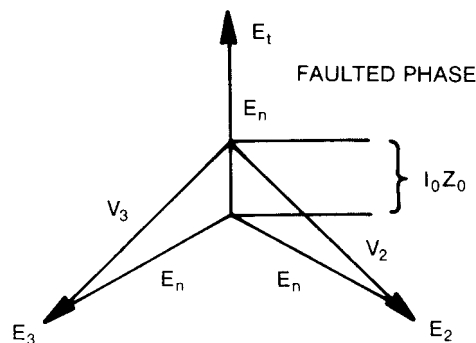

**Figure 2—Phase Diagram for Single Line-to-Ground Fault**

As an example, the voltage to ground on the unfaulted phases of a loaded four-wire multigrounded neutral system can increase by as much as 20%, the exact amount depending upon the location of the fault. In selection of the maximum

<sup>1</sup>Paper No. 71 TP 542-PWR.

overvoltage seen by equipment, however, system voltage regulation must be considered, which results in maximum prefault operating voltage being 5% above the nominal voltage. Consequently, the maximum overvoltage factor for this system is approximately 1.25 ( $1.2 \times 1.05$ ).

The magnitude of overvoltages during ground fault are of this order for the various types of distribution systems:

<u>System</u>	<u>Overvoltage Magnitude</u>
Ungrounded	$1.82 \times E_{LG}$
Four-wire multigrounded (spacer cable)	$1.5 \times E_{LG}$
Three- or four-wire unigrounded (open wire)	$1.4 \times E_{LG}$
Four-wire multigrounded (open wire-gapped)	$1.25 \times E_{LG}$
Four-wire multigrounded (open wire-MOV)	$1.35 \times E_{LG}^*$
$E_{LG}$ = Nominal line-to ground voltage of system	

\*Because the metal-oxide varistor (MOV) arrester is more sensitive to poor grounding, poor regulation, and the reduced saturation sometimes found in newer transformers, many utilities are using a 1.35 factor.

As stated earlier, the expected overvoltage under fault conditions sets the minimum voltage rating of the surge arrester, which in turn has a direct bearing on necessary equipment BIL. From this viewpoint, the four-wire multigrounded neutral open-wire system permits the use of the lowest arrester rating and BIL as compared to other systems with the equivalent nominal system voltage.

### 3.2.2 Ferroresonance

Another potential source of temporary system overvoltage is ferroresonance. Ferroresonance cannot always be entirely avoided in system design, but practical steps can be taken to reduce the probability of occurrence, such as location of fuses and single-phase switches electrically close to the transformer bank; by the use of grounded-wye, grounded-wye transformer connection; connection of single-phase transformers from phase-to-neutral rather than from phase-to-phase; etc.

Single-phase switching, fuse blowing, or a broken conductor can result in overvoltage when ferro-nonlinear oscillations occur between the magnetizing reactance of a transformer and the system capacitance.

A myriad of practical circuit situations can occur that may result in ferroresonant phenomena. Basically, the necessary conditions can arise when one or two open phases result in capacitance being energized in series with the nonlinear magnetizing reactance of a transformer. Sustained overvoltages across the transformer and capacitance may result. A typical circuit condition known to be susceptible to ferroresonance is shown in Fig 3 .

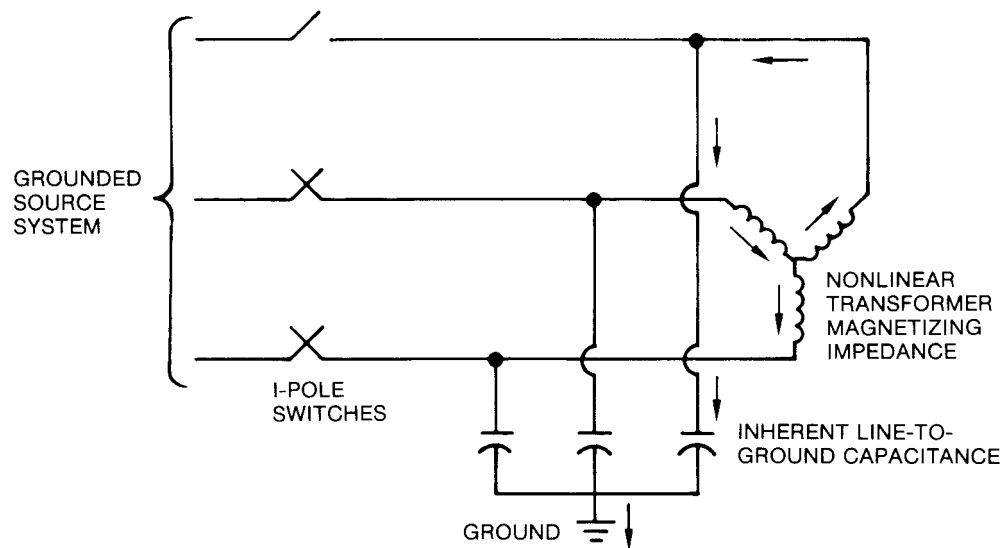

**Figure 3—Single-Phase Switching in a Three-Phase Circuit**

The capacitance can be that of overhead circuits, cables, capacitor banks, or in some cases the inherent capacitance of the transformer itself. Severity and nature of the overvoltages, if any, are a function of the relative magnitude of “L” and “C” and the shape of the transformer saturation characteristic.

### 3.3 Control of Ground Fault Currents

Deliberate limitation of ground fault currents, e.g., by the use of a neutral reactor, falls into two different application areas:

- 1) Effectively grounded systems where ground fault currents are intentionally reduced to permit the use of lower rated switchgear, fuses, connectors, etc., but where the maximum ground fault current is still 60% or more of the available three-phase fault current.
- 2) Impedance grounded systems in which the ground fault current is intentionally limited to values less than 60% (usually less than 25%) of the three-phase value. The principal purpose of such impedance grounding is to reduce the system disturbance caused by ground faults or to permit the system to remain in operation while faulted. Reduced switchgear duty is usually considered only an incidental benefit.

Significant economies and operating benefits may be realized by the judicious limitation of distribution fault currents. These include a possible reduction in the required interrupting capability of circuit breakers, reclosers, and fuses; reduction in the required momentary capability of switches and connectors; reduced possibility of conductor burndown or thermal failure; and reduced possibility of violent failure of distribution apparatus such as transformers, capacitors, and surge arresters [B9], [B26].

Full attainment of these benefits requires attention to the three-phase and phase-to-phase fault currents, as well as the phase-to-ground fault currents. Techniques for simultaneously reducing all types of fault currents include current limiting reactors, reducing the kilovoltampere rating or increasing the impedance of distribution substation transformers, and operation of distribution substations with split rather than paralleled low-voltage buses [B26].

In many cases, control of ground fault currents alone, or in addition to measures for multiphase faults, may be advantageous. The principal reasons for this situation are:

- At distribution substations using the most common transformer connections (delta-wye or wye-delta-wye), the ground fault current for faults close to the station will always be higher than the three-phase fault current. How much higher depends upon the characteristics of the transmission system and the step-down transformer.
- For many types of apparatus, e.g., single-phase distribution transformers, surge arresters, switches, and connectors in single-phase branches, the phase-to-ground fault may be the only possible failure mode.
- Ground fault current control is often less expensive than techniques that also control multiphase fault currents and does not have as detrimental an effect on system losses and voltage regulation.

Ground fault current magnitudes can be effectively reduced by inserting additional impedance (usually inductance) into the neutral-to-ground connection of the distribution substation transformer. The presence of the additional neutral impedance increases the zero sequence impedance ( $Z_0$ ), thereby decreasing the available ground fault current.

For example, assume a 12.5 kV station where the existing fault current levels are 12 000 A three-phase and 14 400 A phase-to-ground. Further assume that it is desired to reduce the maximum ground fault level to 10 000 A. The existing equivalent impedance for phase-to-ground faults [ $X_{eq} = 1/3 (X_1 + X_2 + X_0)$ ] is:

$$X_{eq} = \frac{12\,500/\sqrt{3}}{14\,400} = 0.5\Omega \quad (1)$$

The desired level is:

$$X_{eq} = \frac{12\,500/\sqrt{3}}{10\,000} = 0.72\Omega \quad (2)$$

therefore, a 0.22  $\Omega$  reactor installed in the neutral will produce the desired reduction. (This procedure is not correct for distribution systems that utilize wye-ground/delta connections on distribution transformer banks. Such banks provide an additional source of ground current. Installation of a neutral reactor at the source station of such a system will reduce ground fault current, but not as much as expected, because the grounded transformers on the lines will produce additional current.) The reactor must have a short-time current rating of 10 000 A. In accordance with IEEE Std 32-1972 [B5], the reactor would have a rated voltage of 2200 V (10 000 A  $\times$  0.22  $\Omega$ ) and have insulation of the 2.5 kV class, 60 kV BIL.

On multigrounded four-wire systems, the distribution line neutral conductors should be connected to the ground end of the reactor in order to avoid shunting of the reactor with parallel paths to ground. The reactor must have a continuous current rating large enough to carry the maximum estimated neutral current. IEEE Std 32-1972 [B5] provides for continuous ratings of 3% and 7% for reactors with 10 s and 1 min short-time ratings, respectively. For the reactor chosen in the example, these values would represent 300 A or 700 A continuous ratings.

Neutral reactors decrease ground fault current by increasing the zero sequence reactance ( $X_0$ ) without affecting the positive sequence reactance ( $X_1$ ). Consequently the ratio  $X_0/X_1$ , the Coefficient of Grounding (COG) and the Earth Fault Factor (EFF) are increased [B4]. Referring again to the example, prior to the reactor:

$$X_1 = \frac{12\,500/\sqrt{3}}{12\,000} = 0.6\Omega \quad (3)$$

$$X_0 = \frac{(3)12\,500/\sqrt{3}}{14\,400} - 2X_1 = 0.3\Omega \quad (4)$$

$$\frac{X_0}{X_1} = 0.5 \quad (5)$$

$$\begin{aligned}\text{COG} &= 0.58 \\ \text{EFF} &= 1.0\end{aligned}$$

With the reactor installed,

$$X_1 = \frac{12\,500/\sqrt{3}}{12\,000} = 0.6\Omega \quad (6)$$

$$X_0 = \frac{(3)12\,500/\sqrt{3}}{10\,000} - 2X_1 = 0.96\Omega \quad (7)$$

$$\frac{X_0}{X_1} = 1.6 \quad (8)$$

$$\begin{aligned}\text{COG} &= 0.65 \\ \text{EFF} &= 1.15\end{aligned}$$

The increase in the EFF (or COG) caused by the reactor indicates that there is an upper limit to the amount of reduction in ground fault current that can be achieved. This limit is presented by the amount of overvoltage on the unfaulted phases that can be tolerated for the duration of a ground fault.

Surge arrester application is affected by the maximum 60 Hz voltage that will be present when the arrester is required to reseal. If the EFF is allowed to increase too much, higher rated arresters may be required. This would reduce protective margins and, especially in higher voltage distribution systems, might require higher equipment BIL levels.

The overvoltage on unfaulted phases is also of concern because it is applied to the equipment of customers served from distribution transformers connected from phase to neutral on four-wire systems. Thus, even if arrester application is not a limiting factor, the EFF must not be allowed to increase to a level that can impose intolerable overvoltages on customer equipment. As a rule of thumb, EFF at the substation should not exceed 1.25, which is obtained approximately when  $X_0/X_1 = 2$ . Preferably EFF should not exceed 1.1, which requires an  $X_0/X_1$  of 1.3 or less. At locations remote from the substation, the EFF will exceed these values because of the effects of line impedance [B32]. However, the lower values at the substation are desirable to mitigate the effect of the line impedance and to localize the overvoltages near the fault location rather than requiring the whole system to withstand them. It is realized however, that higher  $X_0/X_1$  ratios have been used satisfactorily.

For systems other than multigrounded four-wire systems and where higher rated surge arresters are acceptable, substantially greater limitation of ground fault currents are possible. Some of the reasons for such limitation are preventing system voltage disturbances during ground faults, reducing ground potential rise at substations and near ground faults, limiting power dissipation in high-resistance faults [B20], providing a means of extinguishing temporary faults without tripping, and providing a means of keeping faulted lines in service. For example, portions of the Swedish distribution system operate normally as high-resistance grounded systems. Upon the occurrence of a ground fault, the system is switched briefly to resonant grounding to extinguish temporary faults. If the fault is not temporary, the grounding resistor is again inserted and relays trip the faulty circuit [B7].

If problems such as communication systems or ground potential rise require considerable limitation of ground fault current (to less than 60% of three-phase fault current), low-resistance grounding provides an attractive alternative to effective grounding. Transient overvoltages are well controlled with this method and relaying is straightforward.

Low-resistance grounding may also be less expensive than effective grounding where a grounding means has to be provided on an ungrounded system by adding a grounding transformer. Since the cost of grounding transformers increases with their current-carrying capability, it may be less expensive to utilize a small grounding transformer with a resistor than to purchase a high capacity grounding transformer suitable for effective grounding. Note that grounding transformers used for this service should have low zero-sequence impedance and neutral insulation rated for system phase-to-neutral voltage.

Low-resistance grounding is also considered to be a good compromise between the conflicting requirements of generator grounding and feeder grounding in systems where feeders are supplied directly at generator voltage.

In systems in which continuity of service must be emphasized, particularly those with customers whose sensitivity to voltage disturbances is such that any voltage dip causes them an outage, high-resistance or resonant grounding can offer considerable service improvement. This is particularly true for systems in which most of the faults are single line-to-ground. Both systems permit the option of allowing grounded lines to remain in service until measures can be taken to maintain service to the affected customers, provided another ground fault does not occur on a different phase. Resonant grounding offers the additional advantage that temporary ground faults are automatically suppressed without any circuit breaker operations or voltage disturbance to customers.

Equipment for high-resistance and resonant grounding will generally be more expensive than for the other methods of grounding systems. If automatic relaying for permanent ground faults is required, it will also likely be somewhat more expensive and complex than that used for effective or low-reactance grounding.

### 3.4 Ground Relaying

The type of grounding employed on a system has a considerable influence on the type of ground-fault relaying equipment needed. Effectively grounded and low-inductance grounded systems have maximum phase-to-ground fault currents of the same order of magnitude as their three-phase fault currents and require rapid fault clearing to minimize voltage disturbances, thermal and mechanical damage to equipment, and hazardous ground potentials. At the same time, the high levels of available ground-fault current allow the use of conventional fault protection techniques such as fuses, phase overcurrent relays, and residual overcurrent (ground) relays.

Systems with low levels of ground-fault current, such as ungrounded, high-resistance grounded, and neutralizer grounded, are often not equipped with automatic ground overcurrent relaying equipment. However, fully selective ground fault relaying can be provided for most such systems through the use of sensitive directional residual watt or var relays. Alternatively, the systems may be temporarily grounded solidly or through a low impedance to permit ground fault clearing by more conventional relays.

Many utilities have experienced difficulty in relaying high-impedance ground faults caused by broken conductors contacting earth or paved surfaces [B24] in four-wire multigrounded neutral systems. The current-to-ground in such cases may be quite low even under favorable conditions [B20]. This problem is particularly noticeable in systems of the 15 kV class and below [B1].

On four-wire multigrounded neutral distribution circuits, the sensitivity of residual overcurrent ground relays is limited by the necessity of setting their pickup above the maximum load unbalance expected on the circuit. This is essential in order to avoid nuisance tripping. The resulting relay settings are usually too high to detect high-impedance ground faults [B1]. Although the presence of the multigrounded neutral conductor provides a moderate increase in the maximum available ground fault current (20% or less), compared to a three-wire line, the effect of the neutral conductor on high-impedance faults (where the current is limited by the high contact resistance to earth) is negligible.

Three-wire ungrounded circuits offer the opportunity to use considerably more sensitive ground relay settings since load unbalance does not cause residual current in the circuit. Four-wire ungrounded circuits can have a similar sensitivity if a current transformer is installed in the neutral as well as the phase conductors. The increased sensitivity

possible with ungrounded systems can be fully realized only if feeder reclosers are equipped with ground fault sensing, and selective coordination with the larger sized fuses is sacrificed.

It should be recognized that even with the highest possible sensitivity, currently available ground relaying techniques cannot detect all high-impedance ground faults. While increased sensitivity may increase the probability of sensing a given fault, tests and experience have shown that there will be faults where the current is so low that it will be undetectable [B20], [B24].

## 4. Special Considerations in Distribution System Grounding

### 4.1 Coordination With Communication Facilities

Since power companies and telephone companies serve the same customers, their outside plant facilities are necessarily closely associated. It is advantageous to the companies, as well as in the interests of the general public, that both plants be coordinated as to location, design, construction, operation, and maintenance in order to avoid unnecessary crossings and conflicts and to reduce the possibility of contacts and the effects of normal and abnormal low-frequency induction and noise.

The method of grounding used on a distribution system has a significant impact on the influence that system may have on communication circuits constructed jointly with the distribution lines. The influence of power distribution lines on communication circuits falls into three categories.

- 1) Short-circuit current flow in communication cable shields and messengers caused by accidental contact with power conductors
- 2) Induced voltages in communication conductors from fault currents or normal load currents in power conductors
- 3) Electrostatically coupled voltages from power conductors to communication conductors

The grounded cable sheaths used in modern telephone plant construction provide almost perfect shielding against electrostatically coupled voltages [B22]. Therefore, the following discussion is confined to the first two types of influence mentioned above.

#### 4.1.1 Accidental Contacts

Communication facilities exposed to possible contact with energized power lines must be properly designed and protected. Fault currents resulting from such contacts are frequently of high magnitude and may be present for several seconds before the contact is broken by the faulted power line being de-energized through operation of its protection equipment or by the facilities being fused open at the point of contact (burndown). Power contacts may produce fusing and extensive dielectric breakdown in the communication plant unless protection measures are employed.

If a power conductor contacts the grounded shields or messengers of telephone facilities, part or all of the power system ground-fault current will flow through these shields or messengers in returning to the source substation. On an effectively grounded system, these currents may be several thousand amperes. The communication plant can withstand such currents only for short periods of time. This short-time capability to carry fault current is usually described as  $I^2t$ , where  $I$  is the root-mean-square (rms) value of the fault current in amperes and  $t$  is the time in seconds. Time  $t$  is generally taken to be the sum of the initial fault-clearing time plus the fault-clearing time of any subsequent reclosures.

The  $I^2t$  capability of telephone support strands varies over a range of approximately  $4 \times 10^6 \text{ A}^2\text{s}$  to  $150 \times 10^6 \text{ A}^2\text{s}$  [B22]. If it appears that the  $I^2t$  of a proposed joint construction project will exceed the telephone plant capability, there are clearly three possible ways to resolve the situation: increase the telephone plant capability, reduce the time that the fault would be energized, or reduce the amount of fault current. Rapid fault clearing is very effective in keeping  $I^2t$



within tolerable limits. However, if distribution ground-fault currents are very high, even fast relaying may not keep the  $I^2t$  within the desired limits. For example, a fault current of 10 000 A cleared in 0.1 s on the initial fault and two subsequent reclosures produces an  $I^2t$  product of 30 million.

In general, only effectively grounded systems have high enough fault currents to cause significant  $I^2t$  values. The ground-fault currents associated with the other grounding classes are sufficiently low that  $I^2t$  is generally not a significant problem for telephone facilities. Means of reducing fault current levels on effectively grounded systems are discussed in 3.3.

#### 4.1.2 Induced Voltages

When telephone plant and power lines occupy parallel routes, magnetic induction of longitudinal voltages may occur in the telephone circuits during power-line ground faults. Low-frequency induction of this nature may reach magnitudes of several thousand volts where the coupling and fault currents are especially large. Magnetic induction by power-line ground fault may affect either aerial, buried, or underground plants. The actual induced voltage varies depending on such variables as ground-fault location, magnitude of the fault current-to-ground, length of exposure, and separation.

A communication cable sheath will produce a substantial degree of shielding against magnetic induction from currents in a paralleling power circuit, provided it is connected to low-impedance grounds at or beyond both ends of the exposure. In some cases, however, it is inconvenient or relatively expensive to provide the low-impedance ground required for this purpose, at the far end (from the central office) of an exposure.

The use of the multigrounded neutral system for distribution lines tends to increase the inductive influence of urban power distribution lines at noise frequencies. At the same time, however, the multigrounded neutral conductor makes available a means of obtaining low-impedance grounds for shielding against both noise and low-frequency induction. In urban and suburban territory, aerial telephone cables and overhead power distribution circuits are generally carried either on jointly used poles or on separate pole lines at roadway separations. Under these conditions, bonding the telephone cable sheath to multigrounded neutral conductors provides a shielding ground that, in most cases, is easier and less expensive to install and maintain than other grounds of equally low impedance.

In telephone circuits entirely in cable, induced noise results solely from magnetically induced longitudinal-circuit voltages and currents acting on telephone circuit unbalances. The electric shielding effect of the grounded cable sheath eliminates electric induction, and the continuous twist and close spacing of the pairs prevents any appreciable magnetic induction directly in the metallic circuit. In telephone circuits with open-wire extensions exposed beyond the end of the cable, metallic circuit induction in the open wire may be important, and this induction is not, of course, affected by cable sheath shielding.

#### 4.1.3 Capacitor Bank Grounding Effects

Noise induced in communication circuits by adjacent distribution lines is caused by a combination of 60 Hz induced voltages and induced voltages of harmonics of 60 Hz. Although the induced voltage of higher harmonics is generally smaller than that caused by 60 Hz, communication circuits are more susceptible to the higher frequencies, and their effects may be more significant.

The type of power-circuit current distribution that produces the highest induced voltage is a distribution of the zero-sequence type, i.e., one with a ground return path. Unbalanced phase-to-neutral connected loads on multigrounded neutral circuits produce this type of ground return current and are the main cause of 60 Hz induced voltages. On systems with multigrounded neutral conductors, only a portion of the total unbalanced current returns in the neutral conductor. The rest returns through the earth. As a result, the summation of the magnetic fluxes of the phases and neutral is not zero, and the residual flux causes 60 Hz induction [B27].

In addition to 60 Hz currents, distribution lines also carry harmonic currents that are produced in magnetic circuits such as distribution transformers and from other nonlinear customer loads. Harmonics that are odd triples of 60 Hz

(i.e., 180 Hz, 540 Hz, etc.), if present equally in the three phases, have a zero-sequence current distribution and consequent earth return path.

Distribution capacitors are linear devices and do not, by themselves, cause harmonic current flow. However, because the impedance of capacitors decreases with increasing frequency, capacitors may form low-impedance paths for harmonics generated in other system loads. The low-impedance paths for harmonics created by capacitor banks may significantly alter the flow of harmonics in a circuit compared to the flow without capacitors present. In inductive coordination problems, this effect may either be helpful or harmful [B28], [B29].

The greatest effect on inductive coordination problems is produced by grounded-wye capacitors, since these provide a low-impedance path to earth for the triple harmonics. Since capacitor bank locations on a distribution circuit are generally chosen based on voltage profile, power factor, and ease of installation, but not harmonic current flow, it may happen that a new capacitor bank installation can create an inductive coordination problem where none existed before. Conversely, judicious location of such capacitors may solve telephone noise problems more economically than any other solution.

Conversion of grounded-wye capacitors to ungrounded-wye will substantially eliminate their effect on triple harmonics, but it requires careful study because of the effects on capacitor switches and capacitor bank short-circuit protection.

Finally, it should be noted that the same types of harmonic flow effects caused by capacitor banks can also be caused by underground distribution areas (cable capacitance) connected to overhead lines.

## 4.2 Use of Grounding Transformers

The feeders from an existing ungrounded source may be effectively grounded by the use of a grounding transformer. Typical grounding transformer connections are the wye-delta, the zig-zag, and the tee connection. The grounding transformer provides a source for zero-sequence current, stabilizes the system neutral, and, if properly sized, permits the addition of a neutral conductor to overhead lines.

The preferred location for the grounding transformer is at the source substation, connected either to the power transformer leads or the station bus. If the grounding transformer is to be used to supply a four-wire distribution system, care must be taken to insure that switching cannot cause the ground bank to be disconnected while the power transformer continues to energize the lines. If the ground bank were to become disconnected, a system ground fault could cause 173% voltage to be applied to the phase-to-neutral distribution transformers connected to the unfaulted phases. Also, in absence of a ground fault, phase-to-neutral overvoltages are possible due to load imbalances.

Small grounding banks made from single-phase distribution transformers have sometimes been used on three-wire ungrounded distribution systems to derive a neutral for a local four-wire system. Such applications must be carefully engineered since the presence of the grounding transformer bank on the distribution line will tend to degrade the sensitivity and selectivity of residual ground relays. Application of small grounding transformer banks on otherwise ungrounded systems should be avoided since it is usually not possible to provide ground-fault relaying that is fully selective and yet protects the ground bank from continuous overcurrent.

The calculations necessary to specify a grounding transformer are discussed in Appendix A.

## 4.3 Grounding of High-Voltage Neutral of Wye-Delta Distribution Transformers

If the high-voltage wye-delta neutral of the transformer bank is connected to the primary circuit neutral, the transformer bank may experience the following:

- 1) Circulating current in the delta in an attempt to balance any unbalanced phase-to-neutral loads connected to the primary line

- 2) Acting as a grounding bank and supplying fault current to any fault on the circuit to which it is connected
- 3) Providing a delta in which triple harmonic currents may circulate

All of these effects may cause the bank to carry current in addition to its normal load current.

When wye-delta connections are used and the high-voltage neutral of the transformer is not connected to the circuit neutral, an open conductor in a three-wire primary results in a single-phase input and output of the bank. If the transformer supplies a motor load, an overcurrent is produced in each three-phase motor circuit. An equal current flows in two conductors of the motor branch circuit, and the sum of the two currents flows in the third.

#### 4.4 Interconnection of Primary and Secondary Neutrals of Distribution Transformers

Distribution transformers currently in use on utility distribution systems involve various methods of grounding primary and secondary neutrals. One practice is to isolate the primary neutral from the secondary neutral, while general practice is to interconnect primary and secondary transformer neutrals (see Annex B).

The practice of isolating the secondary neutral (from the transformer primary neutral, from the primary surge-protection ground, and from the distribution transformer tank) is being used on some ungrounded and ungrounded systems. This practice is based upon a concern that a primary fault to the transformer tank could cause a high voltage to be introduced into the secondary utilization services if the primary and/or tank grounds are interconnected to the secondary neutral. If the secondary service grounds have high resistance, such contact could produce a dangerous shift rise in neutral voltage in the secondary utilization services. This concern has been addressed in Rule 97 of the NESC ANSI C2-1990 [B2].

By using an isolation gap with a 60 Hz breakdown voltage of at least twice the primary line-to-line voltage, but not necessarily more than 10 kV (see NESC ANSI C2-1981 Rule 97D) [B2], it is possible to connect the primary neutral and/or tank ground to the secondary neutral only during a lightning surge. This arrangement, used for ungrounded systems, is desirable since it permits maintaining reasonably good surge protection of the transformer insulation systems by the primary surge arrester.

There are instances on multigrounded systems where primary and secondary neutrals are isolated through a gap similar to that just mentioned, but limited to 3 kV. This practice may have evolved as distribution systems were converted from ungrounded and ungrounded to multigrounded operations.

On multigrounded neutral systems, it is common practice to interconnect the primary and secondary neutrals and to use a single ground for these neutrals as well as for the transformer tank and surge protection (see Fig B.1 ). This technique effectively parallels all the primary grounds with the secondary grounds and provides lower grounding resistance for both the primary and secondary systems as well as for the transformer surge protection. A disadvantage to this practice is the occasional occurrence of abnormally high neutral-to-earth voltage (stray voltages) on the secondary system emanating from the primary neutral (see Appendix B).

On ungrounded and ungrounded systems, there is no multigrounded primary neutral that can be interconnected to augment the grounding of the secondary neutral.

## 5. Bibliography

[B1] AIEE Committee Report, "Sensitive Ground Protection," *AIEE Transactions*, vol. 69, p. 473, 1950.

[B2] ANSI C2-1990, National Electrical Safety Code.

[B3] ANSI C82.1-1985, American National Standard Specifications for Fluorescent Lamp Ballasts.

- [B4] IEEE C62.92-1989, IEEE Guide for the Application of Neutral Grounding in Electrical Utility Systems, Part I—Introduction (ANSI).
- [B5] IEEE Std 32-1972 (Reaff. 1991), IEEE Standard Requirements, Terminology, and Test Procedures for Neutral Grounding Devices (ANSI).
- [B6] NFPA 70-1990, National Electrical Code.
- [B7] Alm, Anders, “Relay Schemes for Modular Substations,” *ASEA Journal*, vol. 46, pp. 9-12, 1973.
- [B8] Aucoin, B. M., and Russell, B. D., “Distribution High Impedance Fault Detection Utilizing High Frequency Current Components,” *IEEE Transactions on Power Apparatus and Systems*, pp. 1596-1606, June 1982.
- [B9] Aver, Siegfried and Capra, Raymond, “Limiting Fault Currents on the Primary Distribution System,” *Transmission and Distribution*, p. 22, April 1980.
- [B10] Balser, S. J., Caprino, B. A., Delaney, L., and Lawrence, D. J., “Detection of High Impedance Faults: Microprocessor Implementation,” EPRI, Palo Alto, CA: EPRI Final Report, 1985.
- [B11] Balser, S. J., Clements, K. A., and Kallaur, E., “Detection of High Impedance Faults,” EPRI, Palo Alto, CA: EPRI EL-2413, June 1982.
- [B12] Bierman, G. J., *Factorization Methods for Discrete Sequential Estimation*. New York: Academic Press, 1977.
- [B13] Bishop, M. T., Eichler, C. H., and Lee, R. E., “Development and Testing of an Electromechanical Relay to Detect Fallen Distribution Conductors,” *IEEE Transactions on Power Apparatus and Systems*, pp. 1634-1650, June 1982.
- [B14] Brown, H. H. and Gross, E. T. B., “Experience with Resonant Grounding in a Large 34.5 kV System,” *IEEE Transactions on Power Apparatus and Systems*, vol. PAS-85, pp. 541-547, May 1966.
- [B15] Carr, J. and Hood, G. L., “High Impedance Fault Detection on Primary Distribution Systems,” Report 78-75 for the Canadian Electrical Association, Nov. 1979.
- [B16] “Correcting Inductive Interference Problems,” *Electrical World*, pp. 76-79, June 15, 1976.
- [B17] “Correcting Inductive Interference Problems,” *Electrical World*, pp. 45-47, July 1, 1976.
- [B18] Crow, E. L., Davis, F. A., and Maxfield, M. W., *Statistical Manual*. New York: Dover Publications, Inc., 1960.
- [B19] Herzog, E., “Resonant Grounding of Distribution Systems,” in *Proceedings of the Midwest Power Conference*, vol. 11, pp. 171-178, 1949.
- [B20] Hunt, L. F. and Vivian, J. H., “Sensitive Ground Protection for Radial Distribution Feeders,” *AIEE Transactions*, vol. 59, pp. 84-90, 1940.
- [B21] Johnson, I. B., Schultz, A. J., Schultz, N. R., and Shares, R. B., “Some Fundamentals of Capacitance Switching,” *AIEE Transactions*, vol. 74, part III, pp. 727-736, 1955.
- [B22] Joint Subcommittee on Development and Research, “Effects of Bonding Exchange Aerial Telephone Cable Sheaths to Multigrounded Power Neutrals,” EEL/AT&T, Aug. 1940.

- [B23] Joint Subcommittee to Study Buried Distribution Systems, “Buried Power and Telephone Distribution Systems—Analysis of Primary Cable Fault Tests and Evaluation of Experience with Random Separation,” EEI/AT&T, EEI Publication 68-62, June 1968.
- [B24] Kilar, L. A., Lee, R. E., Resado, M., and Shankle, D. F., “Improved Relay Schemes for the Detection of Fallen Conductors on Three Phase, Four Wire, Distribution Circuits,” presented at the 7th Annual IEEE/PES T & D Conference and Exposition, Atlanta, GA, April 1979.
- [B25] Logan, J. T. and Richardson, Olan, “Arc Frequency Component Relaying—Summary of Experience on the Georgia Power Company System,” Internal Report, Atlanta, GA, Jan. 15, 1937.
- [B26] Nishikawara, K., “Limiting Available Distribution Fault Currents at Substations,” *Transmission and Distribution*, Jan. 1978.
- [B27] Szabados, B. “The Neutral Current Phase Shift on Distribution Feeders Theory and Field Tests,” in Conference Proceedings 12-3-III, vol. III, NTCH 76 Dallas, Dec. 1976.
- [B28] Szabados, B. and Burgess, E., “Optimizing Shunt Capacitor Installations Using Inductive Coordination Principles,” *IEEE Transactions on Power Engineering Systems*, July 1976.
- [B29] Szabados, B., Burgess, E., and Noble, W., “Harmonic Interference Corrected by Shunt Capacitors on Distribution Feeders,” *IEEE Transactions on Power Engineering Systems*, July 1975.
- [B30] Szabados, B. and Noble, W. A., “A New Look at Inductive Coordination,” CEA, March 1974.
- [B31] Tomlinson, H. R. and Hunt, F. B., “Operation of a Ground Fault Neutralizer on a Regulated Distribution System,” *AIEE Transactions*, vol. 68, part II, pp. 1321-1328, 1949.
- [B32] Working Group of SPDAG, Subcommittee of SPDC, “Voltage Rating Investigation for Application of Lightning Arresters on Distribution Systems,” *IEEE Transactions on Power Apparatus and Systems*, pp. 1067-1074, May/June 1972.

## Annex A Specifying a Zig-Zag Grounding Transformer

### (Informative)

This appendix covers the more usual electric utility application of grounding transformers, where the grounding is considered to be reactance grounding rather than high-resistance grounding (frequently used in industrial applications). With reactance grounding, the ground current (for a line-to-ground fault) will normally not be less than 25% of the three-phase fault current. The following is a typical example of calculations for a grounding transformer, using per-unit quantities.

Basically, the questions asked when specifying a grounding transformer are

- 1) What is the system voltage?
- 2) What is the desired system effect?
- 3) What is the three-phase short-circuit duty?
- 4) What is the ratio of  $R_1/X_1$ ?
- 5) What is the ratio of  $R_0/X_0$ ?
- 6) What is (either)
  - a) Desired ground current, or
  - b) Desired ratio of  $Z_0/Z_1$ , or
  - c) Desired value of ohms/phase?

With the answers to these questions, the following can be determined:

- 1) The ohms/phase required in a zigzag grounding transformer
- 2) The rating of the transformer
- 3) Either the ratio of  $Z_0/Z_1$  or the total ground current, depending on which one was specified
- 4) The effect of the transformer impedance tolerances on the result
- 5) The maximum sustained voltage that can occur on an unfaulted phase during a phase-to-ground fault
- 6) The equivalent pricing kilovoltamperes for
  - a) A zig-zag three-phase grounding transformer for various time duties
  - b) Wye-Delta ratings for the same short-time duties
- 7) The impedance of the specified transformer for each of the above ratings

The following subsections contain a typical series of calculations for a zig-zag grounding transformer.

### A.1 Problem

The three-phase fault duty at a substation is 525 MVA on the ungrounded 34.5 kV system. It is desired to ground this system using a zig-zag grounding transformer and limit the ground-fault current to 5500 A. Specify the grounding transformer.

## A.2 Solution

Use 100 MVA Base

$$\text{Rated Kilovoltampere} = 34.5$$

$$\begin{aligned} \text{Base Ohms} &= (1000) (\text{kV})^2 / \text{KVA} \\ &= 11.9 \end{aligned}$$

$$\begin{aligned} \text{Base Amps} &= \text{KVA} / (\text{KV} \times \sqrt{3}) \\ &= 1673 \text{ A} \end{aligned}$$

$$Z(1) = Z(2) = 100/525 = 0.190 \text{ per unit (p.u.)}$$

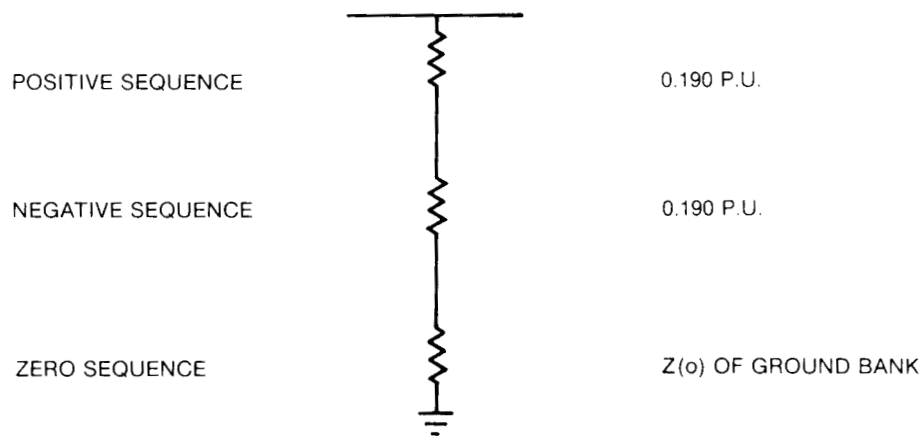

Figure A.1—Impedance Diagram

$$I(G) = \frac{5500}{1673} = 3.29 \text{ p.u. A}$$

$$I(o) = \frac{3.29}{3} = 1.10 \text{ p.u. A}$$

$$Z(\text{total}) = \frac{1.0}{1.10} = 0.913 \text{ p.u. } \Omega$$

$$\begin{aligned} Z(\text{total}) - 2Z(1) &= 0.913 - 0.190 - 0.190 \\ &= 0.533 \text{ p.u. } \Omega \end{aligned}$$

$$\text{In Ohms: } Z(o) = 11.9 \times 0.533 = 6.3 \Omega / \text{phase for grounding transformer}$$

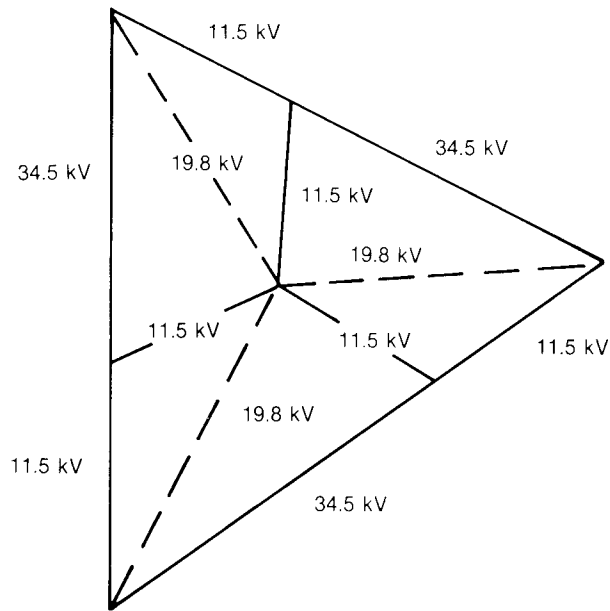

**Figure A.2—Phase Relationships in a Zig-Zag Transformer**

When a wye-delta transformer is used as a grounding bank, the delta serves only to provide a path for the zero-sequence current. The actual (short-time) rating in kilovoltamperes is:

$$kVA = \frac{(\text{Line-to-Line kV})(\text{Neutral Amps})}{\sqrt{3}} \quad (\text{A.1})$$

For a zig-zag grounding transformer, since both windings are active in the primary circuit, the actual (short-time) rating in kilovoltamperes is:

$$kVA = \frac{(\text{Line-to-Line kV})(\text{Neutral Amps})}{\sqrt{3}} \quad (\text{A.2})$$

From this it is apparent that the required kilovoltamperes are less for a zig-zag bank than for a wye-delta bank.

Since a grounding transformer is normally only required to carry short-circuit ground current until the circuit breakers clear the fault, it is common to rate it on a short time such as 10 s. Under these circumstances the physical size (and resulting cost) is considerably reduced. If it is required to carry a continuous percentage of unbalanced current, this will reduce the amount of savings possible.

The requirements of the application usually require a specific amount of reactance in the transformer (to limit the ground-fault current). If this results in a transformer requiring a special design, the cost is increased.

Since the 5500 A ground-fault current will be interrupted by relay operation in a few seconds or less, the grounding transformer can be rated for short-time operation. Ten seconds would be a typical rating. A 1 min rating could be considered if the 34.5 kV system is subject to many faults in quick succession as, for example, during a lightning storm.

If constructed as a wye-delta transformer, the proposed grounding transformer would have a short-time kilovoltampere rating of  $(34.5 \text{ kV} / \sqrt{3}) (5500) = 110 \text{ MVA}$ . In zig-zag form the short-time rating would be  $(34.5 \text{ kV} / 3) (5500) = 63.25 \text{ MVA}$ . In both cases the actual frame size will be considerably smaller than the megavoltampere rating indicates, because of the use of a short time rating.



### A.3 Grounding Effectiveness

In the above example, no limits were placed on the maximum acceptable EFF. The resulting design has an  $X_0/X_1$  ratio of  $0.5333/0.190 = 2.8$ . Since resistance is considered negligible, Fig A.1 in IEEE C62.92-1989 [B4] indicates a COG of 0.75. The corresponding EFF is  $0.75 \times \sqrt{3} = 1.30$ .

Since the COG is less than 80%, the substation is effectively grounded and the use of surge arresters rated at 80% of line-to-line voltage could be considered *at the substation*. At locations distant from the substation, the combined impedance of the line and the substation must be considered.

If the desired ground-fault current had been specified to be a lower value (e.g., 3000 A), the EFF would have been higher and, consequently, higher rated arresters would have been required.

### A.4 Multigrounded Neutral System

In a multigrounded neutral system, it is often considered desirable to hold the unfaulted phase voltage to less than 75% of the line-to-line voltage or a 1.3 EFF.

With an EFF of 1.3, customers served from transformers connected from the unfaulted phases to neutral will experience up to 30% overvoltage during a fault.

In order to reduce the overvoltage to 20% (COG of 70%), an  $X_0/X_1$  ratio of approximately 2.0 must be obtained. Using the values from the above example,  $X_0 = (2.0) (.190) = .38$  p.u. The ground bank impedance in ohms is

$$11.9 \times 0.38 = 4.5\Omega/\text{phase} \quad (\text{A.3})$$

The corresponding maximum ground fault current is

$$\frac{3 \times 1673}{0.19 + 0.19 + 0.38} = 6600 \text{ A} \quad (\text{A.4})$$

The kilovoltampere rating and physical size of the grounding transformer will be proportionally larger than the previous example.

Greater reduction in unfaulted phase voltage can, of course, be obtained by further reducing  $X_0$ . However, at points some distance from the substation, the EFF is influenced principally by the line impedances. Consequently, reducing the EFF at the substation, even to 1.0, will not greatly influence the EFF at remote locations. However, it will help to confine the overvoltages to a smaller area.

### A.5 Continuous Rating

In an application on a multigrounded neutral system, the grounding transformer must have the capability to carry some continuous neutral current. An estimate must be made of the maximum expected load imbalance in order to specify this rating. A grounding transformer constructed in accordance with IEEE Std 32-1972 [B5] will have a continuous rating of 3% for a 10 s rated unit. This value would correspond to a 200 A continuous rating for the 6600 A transformer specified above. If higher values of continuous current are required, the size and cost of the grounding transformer may increase. A 1 min rated unit would have a continuous current rating of 7%.

## Annex B Techniques for Interconnecting Primary and Secondary Neutrals (Informative)

### B.1 Background

Stray voltage is an undesirable byproduct of the increased use and complexity of electrical equipment. When a stray-voltage problem exists, it often has a multiplicity of causes. For this reason, it is a time-consuming and tedious process to track down and eliminate, often involving the power supplier, the local electrician, and various equipment manufacturers.

In most cases, the major components of stray voltage are “on-site” generated. In some cases, a component of stray voltage enters from the system of the power company via the primary neutral to secondary neutral interconnection. To minimize the possibility of on-site generated stray-voltage problems, it is essential that the wiring be in compliance with the NEC [B6]. One of the problems in eliminating stray voltage is that the power company cannot work on the secondary service, and the local electrician cannot work on the primary service. Therefore, no one party can usually go to a farm and take the necessary measurements to determine the causes of, and eliminate, stray voltage when it is comprised of components generated both on-farm and by the power company.

Several solutions have been proposed for blocking or isolating the voltage on a utility neutral. One approach is to disconnect the primary neutral from the secondary neutral at the distribution transformer and install a spark gap or distribution arrester. While this approach can provide very effective isolation, it does not prevent potentially hazardous high voltage from being impressed on the secondary side if a primary-to-secondary fault should develop within the transformer. The reasons are expanded upon in the next subsection.

### B.2 Problem

If a primary-to-secondary fault developed within the transformer and the neutrals were not connected, the resistance of the return current path could be so high that not enough fault current would flow to enable the primary protective device to clear the fault. High voltage would then be impressed on the secondary for an extended period of time, posing a risk to humans, animals, and equipment.

When a distribution arrester is used as an isolator, it may result in an unsafe voltage on the secondary service and neutral. A typical silicon carbide distribution arrester requires a voltage of approximately 1.5 times its duty-cycle rating before it sparks over at 60 Hz. Therefore, there is no failure condition that will result in a 60 Hz voltage across the arrester that will cause it to conduct and provide a low-impedance return path for fault current to flow along. Hence, a high voltage can exist on the secondary service for an extended period of time.

Reducing the breakdown level by installing a spark gap may still result in a higher than normal voltage on the secondary for those transformer failure conditions that impose a voltage on the secondary up to the 60 Hz breakdown voltage of the gap. Further, when a transformer failure imposes a voltage on the secondary below the 60 Hz breakdown of the spark gap, the fault will persist longer—or indefinitely—because the reduced driving voltage for the same system grounding impedance may not allow sufficient current flow to blow the primary fuse.

Another approach is to install a 1:1 isolation transformer on the secondary side and then leave the primary and secondary neutral disconnected at the isolation transformer to obtain isolation. Now, in the event of primary-to-secondary fault in the isolation transformer, the maximum voltage that could be imposed on the secondary neutral is reduced from the primary distribution voltage to 240 V—a considerable improvement. Although this approach is occasionally used, several drawbacks stop it from being an ideal solution.

- 1) The farm must absorb local lightning strikes without the benefit of dispersal through the utility primary neutral system.

- 2) The utility system must absorb lightning strikes without benefit of dispersal through the secondary neutral system.
- 3) The farmer must pay for the isolation transformer, its installation, and all operating losses since it is on the secondary side.

### B.2.1 Solution 1—Neutral Isolator—SCR

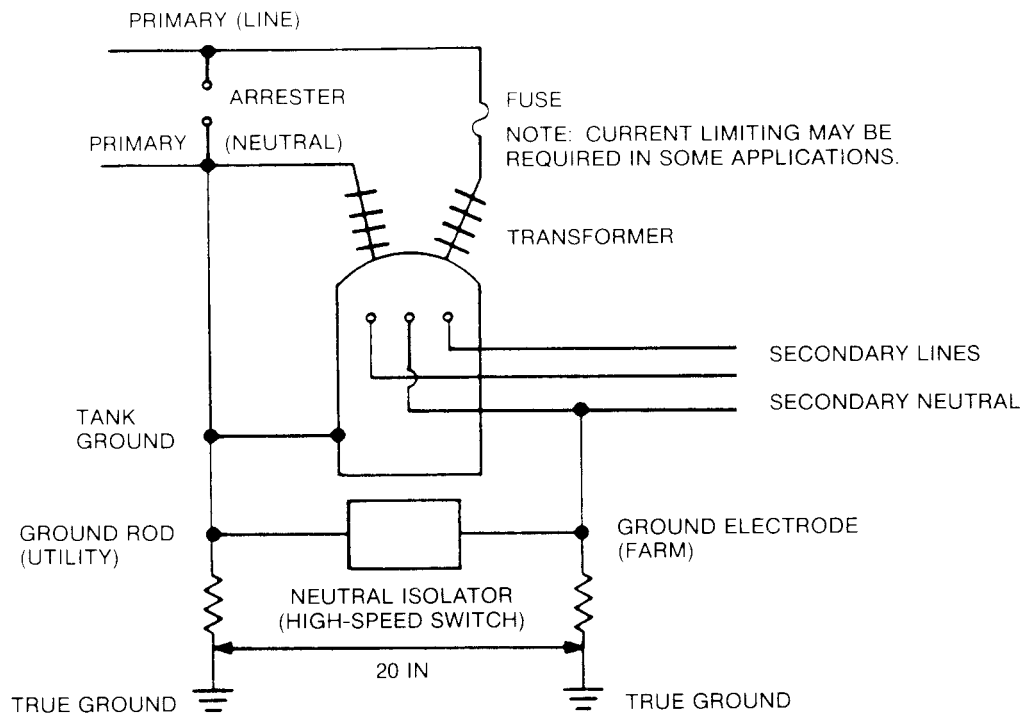

**Figure B.1—Neutral Voltage Isolator Connection for a Typical Overhead Transformer**

To obtain the required isolation of any voltage on the utility neutral, the basic requirement is to have sufficient electrical separation of the primary and secondary ground systems so that when the neutrals are isolated, the voltage on the primary neutral will not appear on the secondary neutral. To provide the required protection to both the utility and the farmer, it is essential to have the neutrals instantly and solidly connected in the event of any system disturbance that causes the voltage of one neutral to rise above a predetermined threshold relative to the other (i.e., a primary-to-secondary winding failure of the transformer, a lightning surge, etc.). Basically, what is required is a very-high-speed voltage-triggered switch, capable of withstanding the various voltages and currents imposed on it under all foreseeable conditions. Towards this end, a high-speed voltage-triggered switch has been developed for this application that can, when required, instantly (i.e., within 2  $\mu$ s) reconnect the neutral conductors and carry large magnitudes of current with minimal voltage drop. To obtain the switching speed desired, the switch has been designed using solid-state components.

The product developed for neutral voltage isolation is installed as illustrated in Fig B.1 for a typical two-bushing overhead transformer. It is also applicable to single-bushing transformers and padmounted transformers. Tests of the switch, which is being called a neutral isolator, have been conducted to demonstrate its applicability to 15 kV and 25 kV distribution systems. Since system voltage is not a critical parameter with the design approach selected, this product is expected also to be applicable to 35 kV class distribution systems. Under normal conditions, the voltage from the primary neutral or the secondary neutrals to true earth ground will be less than several volts. By designing the neutral isolator so that it will be open (i.e., neutrals disconnected) when the voltage across it is less than a predetermined threshold voltage (selected to be greater than the normal voltage difference between neutrals), the

required isolation is obtained. The only time the neutral isolator will close (i.e., reconnect the neutrals) is when the voltage across its terminals attempts to exceed this voltage threshold, such as during a primary-to-secondary transformer fault when the voltage on the secondary neutral would rise due to the fault current flowing back to the primary neutral via the earth. When this current flow results in a voltage across the neutral isolator terminals that attempts to exceed its switching voltage threshold, the neutral isolator switch closes and shunts the current through the effectively reconnected primary and secondary neutrals. The neutral isolator is self-protected against transients, and its turn-on time after the threshold voltage is reached is less than 2  $\mu$ s. Initially a 12 V (peak) switch threshold voltage was selected; however, during initial field trials, primary neutral-to-earth voltages higher than this were encountered. As a result, a 36 V peak (25 V ac rms) switching threshold was selected. This level is below the lowest voltage level that might be considered hazardous, and it is above the highest primary neutral-to-earth voltage expected. However, from a utility perspective, it would appear desirable to keep any neutral-to-earth voltage below the threshold of human perception. A fundamental requirement of this approach is that the voltage across the switch under normal conditions, due to voltage on the primary and secondary neutrals, be less than the switch threshold trigger voltage to obtain isolation.

### B.2.2 Solution 2—Isolating Gap

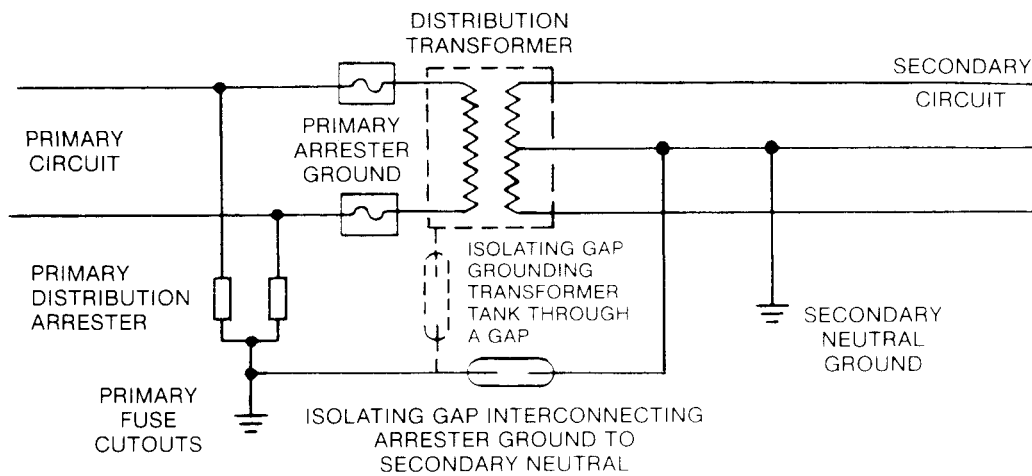
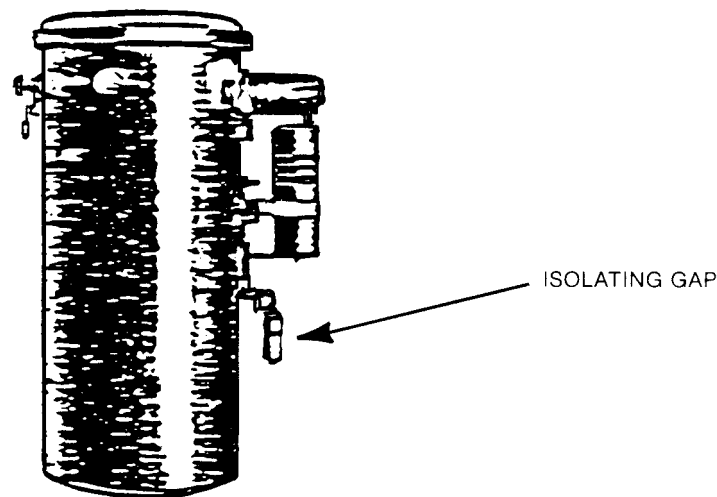

Figure B.2—Primary-to-Secondary Isolating Gap



**Figure B.3—Transformer With Isolating Gap**

Porcelain-enclosed isolating gaps were developed expressly to make possible efficient interconnection through a gap, where it is desired to isolate the primary lightning-arrester ground from the secondary neutral. A typical application gap serves to isolate the arrester ground from the secondary neutral under normal operating conditions. However, in the event of severe discharge or where the arrester-ground resistance is high, the isolating gap sparks over, thereby limiting the impulse voltage stress on the transformer primary-to-secondary insulation, and equalizing the impulse voltage between the arrester ground and secondary neutral grounds.

These gaps can also be used wherever distribution-transformer tanks are to be grounded through a gap, as shown in Fig B.2 and by Fig B.3 .

Isolating gaps are simple in design and sturdy in construction. They can be quickly and easily installed and are exceptionally dependable in service.

Two different designs of isolating gaps are listed to satisfy various requirements of mounting and application. For each of these designs, standard spark-potential ratings have been established at 6 kV, 11 kV, and 14 kV rms. These ratings are average values subject to about  $\pm 10\%$  tolerance.

Ratings of the gaps are as follows:

**Table B.1—Gap Ratings**

<b>Primary Voltage</b>	<b>60 Hz Sparkover (kV rms)</b>	<b>Impulse Sparkover (kV Crest)</b>
2400 ungrounded	6	11
4160 grounded	11	17.5
4800 ungrounded	11	17.5
6900 ungrounded	15	25
8320 grounded	15	25
Higher	15	25

### B.2.3 Solution 3—Low-Voltage Sparkover Gap

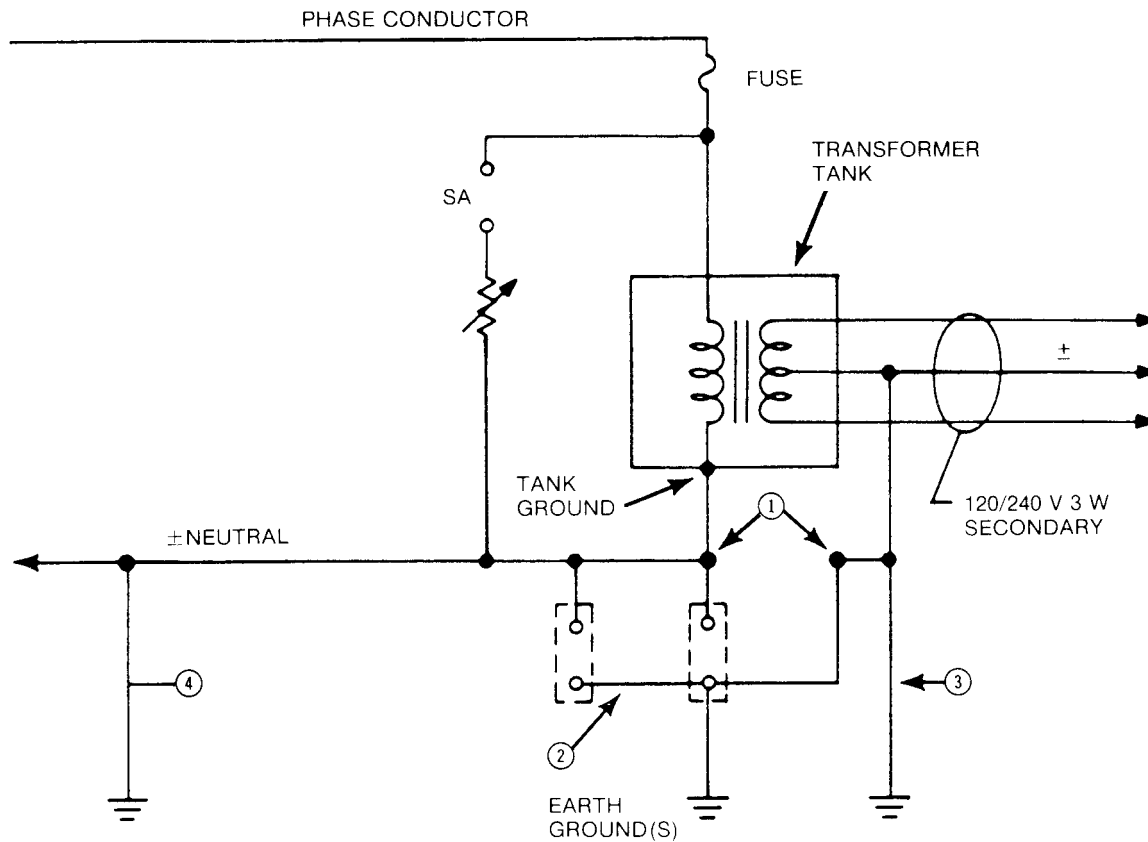

- ① ISOLATE SECONDARY NEUTRAL FROM PRIMARY NEUTRAL
- ② INTERCONNECT PRIMARY AND SECONDARY NEUTRALS THROUGH SECONDARY GAPS
- ③ CONNECT SECONDARY NEUTRAL TO DRIVEN GROUND
- ④ CONNECT PRIMARY NEUTRAL TO DRIVEN GROUND, ONE SPAN AWAY

**Figure B.4—Schematic of Interconnection of Primary and Secondary Neutrals Through Secondary Gaps**

One utility is solving new complaints by separating primary and secondary neutrals with a low-sparkover voltage gap. As shown in Fig B.4 , two gaps are connected in parallel. One gap, a porcelain spool with a 60 Hz dry-flashover rating of about 5 kV, provides mechanical stability. The second gap, a modified photocell-type arrester with a 60 Hz dry-flashover rating of 1 kV, is used to grade the sparkover of the first gap. In addition, the secondary neutral is connected to two earth grounds, and the primary neutral is connected to a third earth ground one span away. This arrangement satisfies the requirements of the 1984 revisions to the NESC [B2].

A question arises regarding the likelihood of a primary fuse not operating for an internal transformer fault between primary and secondary windings when a gap has been installed. Referring to Fig B.4 , primary-secondary fault current flows only to earth because the normally open neutral gap is in the metallic neutral return circuit. However, as secondary neutral potential rises during the phase-to-ground fault, voltage across the gap also rises and eventually arcs across at about 1 kV, closing the gap and providing an additional path for the fault current.

### B.2.4 Solution 4—Saturable Reactor

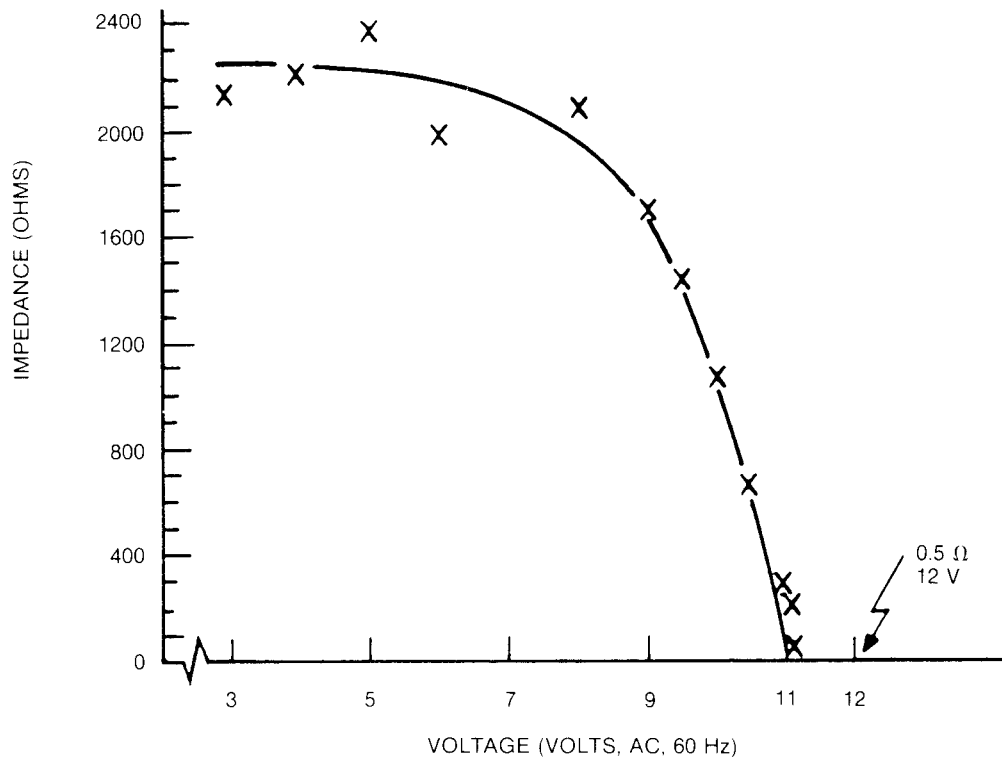

**Figure B.5—Impedance Curve (60 Hz AC) for One Saturating Reactor**

Another approach makes use of a saturating reactor for separating the grounded (neutral) conductors from the grounding conductors, including the grounding electrode, at the building service entrance. Under normal conditions, the reactor acts as the large impedance of a voltage divider. The voltage divider consists of the reactor in series with the building grounding system. Since potential fault currents for the secondary are larger than for the primary, the specifications for this application may be more stringent than for application of the same principle at the distribution transformer.

This approach has the advantage of low cost of the device. However, since its function is dependent on complete separation of grounding and neutrals within the service and separation of grounding systems between services, installation may be difficult in some existing facilities.

NOTE — Devices for this approach have not received listing by Underwriter's Laboratories for such an application. The concept has not been determined to be acceptable under the NEC [B6], therefore its use in the United States at this time cannot be recommended unless approved by appropriate electrical inspection authorities on an experimental basis.

### B.2.5 Telephone Sheath Continuity

All telephone companies contacted so far have indicated that the sheath must and is allowed to be broken (discontinued). If this were not the case, the telephone sheath continuity could bypass the neutral device.